

SECTION C-C

TERMINAL COMPARTMENT DETAIL

NOTE: UNLESS OTHERWISE SPECIFIED, LOCATE TERMINAL COMPARTMENT 1 FOOT ABOVE THE POLE BASE AT 180 DEGREES ON THE POLE'S RADIAL INDEX.

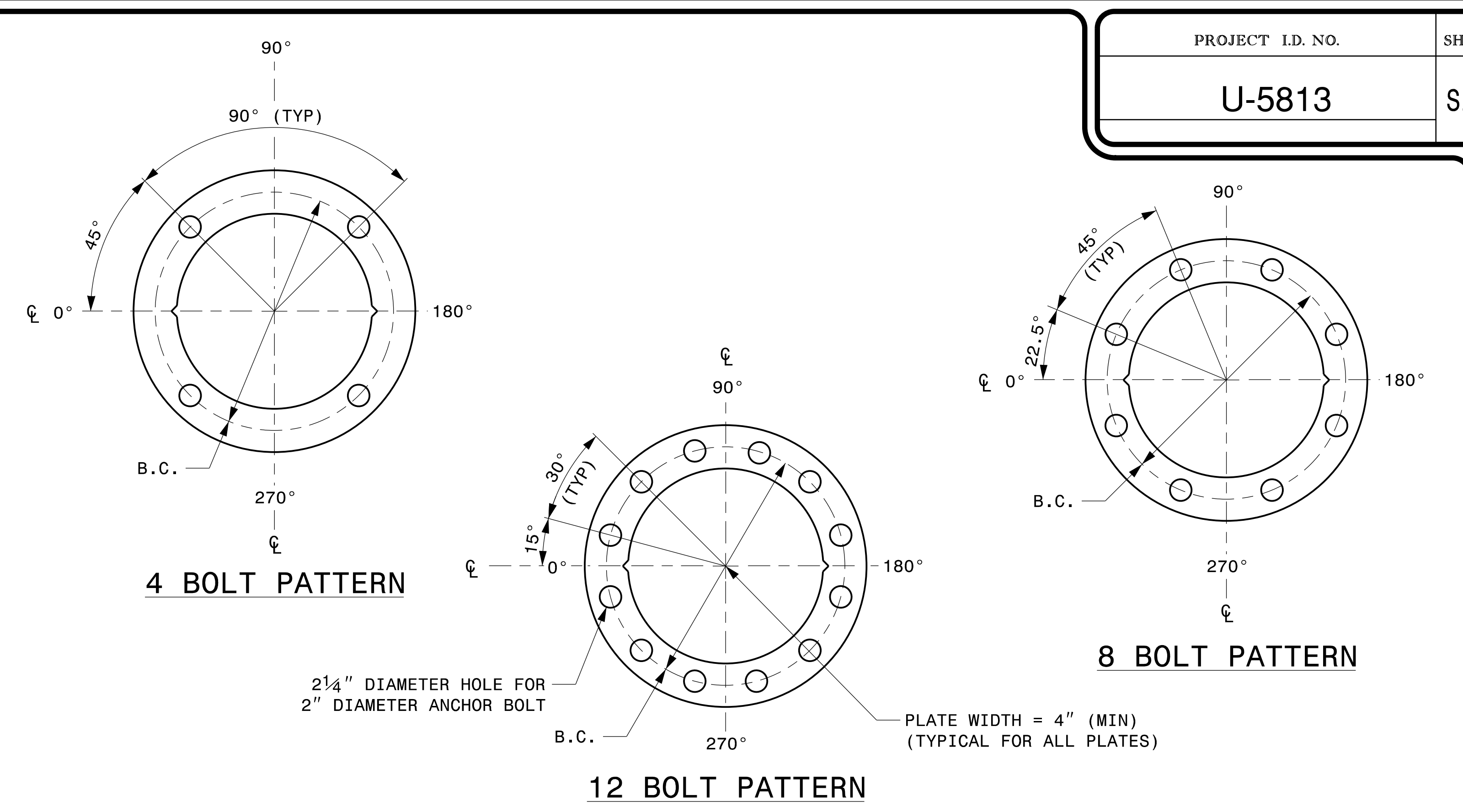

CONSTRUCT TEMPLATES AND PLATES FROM 1/4" (MIN) THICK STEEL. GALVANIZING IS NOT REQUIRED.
BASE PLATE TEMPLATE AND ANCHOR BOLT LOCK PLATE DETAILS

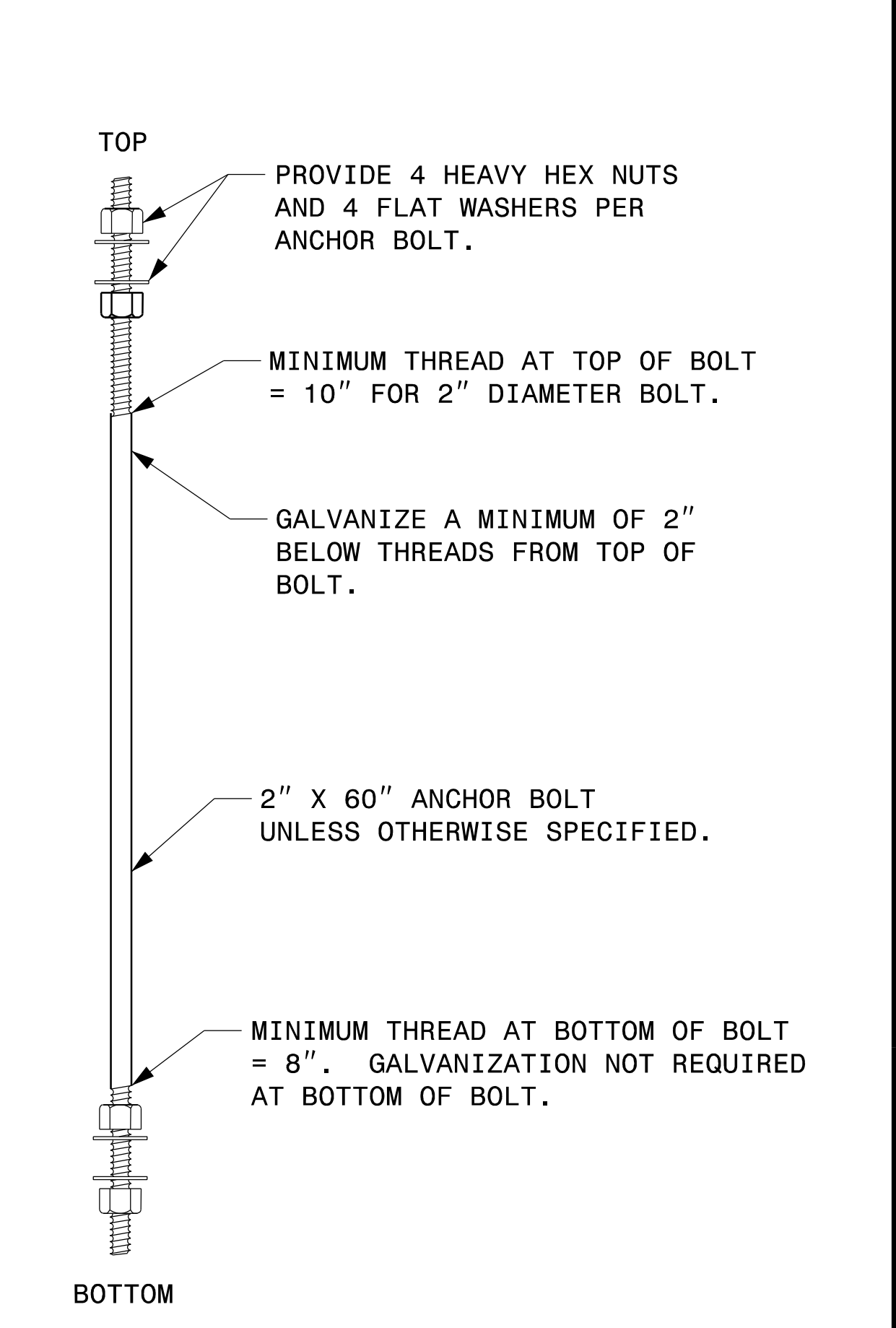

ANCHOR BOLT DETAIL

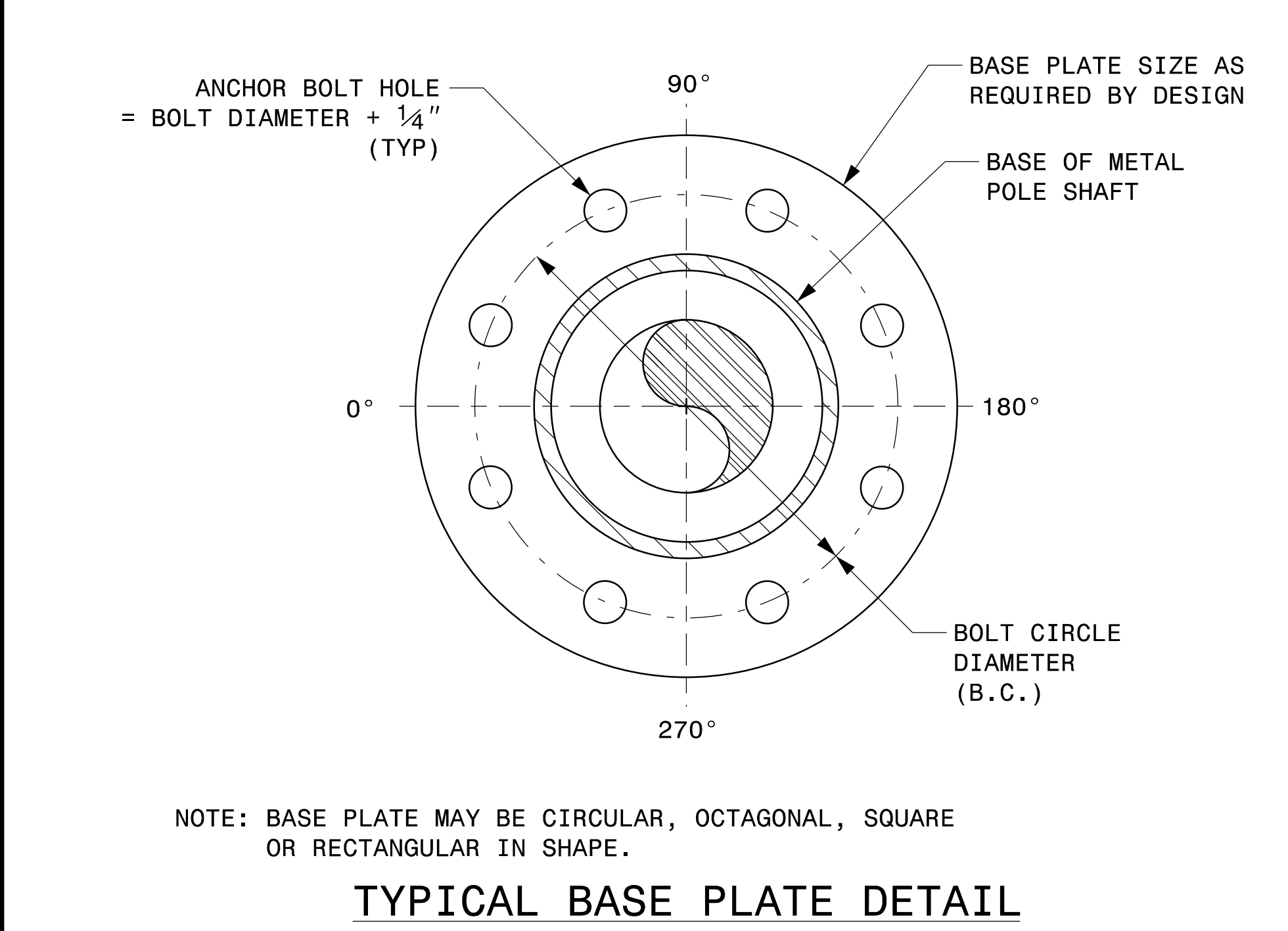

TYPICAL BASE PLATE DETAIL

NOTE: BASE PLATE MAY BE CIRCULAR, OCTAGONAL, SQUARE OR RECTANGULAR IN SHAPE.

MFG _____	MFG. DATE: MM/YY _____
SHAFT D/T/L/Y _____	_____
ARM-A D/T/L/Y _____	_____
ARM-B D/T/L/Y _____	_____
A.B. DIA./B.C./L/Y _____	_____
NCDOT SIG. INV. NO. _____	_____
NCDOT POLE NO. _____	_____

MFG _____	MFG. DATE: MM/YY _____
SECTION D/T/L/Y _____	_____
NCDOT SIG. INV. NO. _____	_____
NCDOT POLE NO. _____	_____

ARM I.D. TAG
 (PROVIDE ON EACH SECTION OF A MULTI-SECTION MAST ARM)

SHAFT I.D. TAG
 (PROVIDE ON SHAFT OF STRAIN POLES AND MAST ARM POLE SHAFT)

NOTES:

1. D = DIAMETER, T = THICKNESS, L = LENGTH, Y = YIELD STRENGTH
2. A.B. = ANCHOR BOLT
3. B.C. = BOLT CIRCLE OF ANCHOR BOLTS
4. IF STANDARD DESIGN, INCLUDE CASE NUMBER IN ADDITION TO POLE NUMBER ON "NCDOT POLE NO." LINE.
5. SIGNAL INV. NUMBER AND POLE I.D. NUMBER. SEE DRAWING M3 AND M4 FOR MOUNTING POSITIONS OF I.D. TAGS.

IDENTIFICATION TAG DETAILS



Prepared in the Offices of:		Typical Fabrication Details For All Metal Poles	
PLAN DATE: SEPTEMBER 2023	DESIGNED BY: C.F. ANDREWS	REVISIONS	INIT. DATE
PREPARED BY: K.C. DURIGON	REVIEWED BY: D.C. SARKAR		

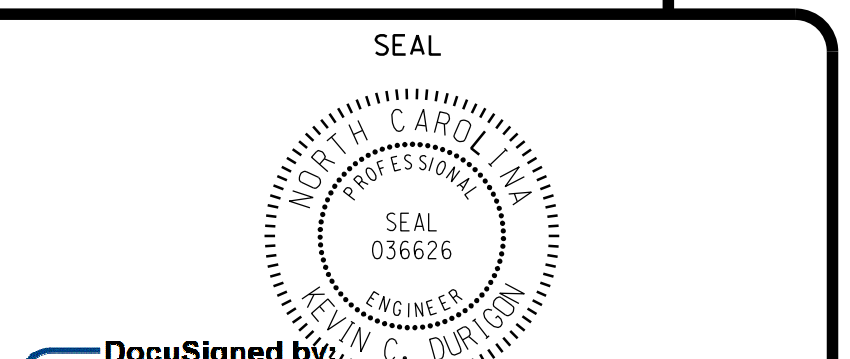

DocuSigned by:
Kevin Durigon
 09/21/2023
 DATE

21-SEP-2023 07:56 S:\ITS\SSU\115 Signal\Signal Design\Section\Structures\Drawings\2024 Metal Pole Std Drawings for LRF\2024 Sig.M2 Std. Fabrication Details-A11 Poles.dgn

Fabrication Details – All Metal Poles