

GEOTECHNICAL ENGINEER
 ENGINEER

 DocuSigned by: *H. Stephenson* 01/03/2024
 C44788202314CC
 SIGNATURE DATE SIGNATURE DATE
**DOCUMENT NOT CONSIDERED FINAL
 UNLESS ALL SIGNATURES COMPLETED**

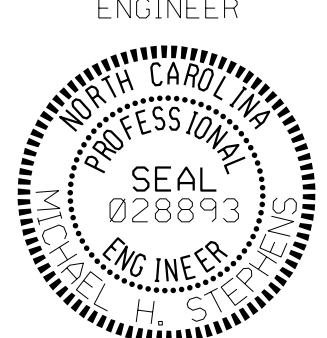
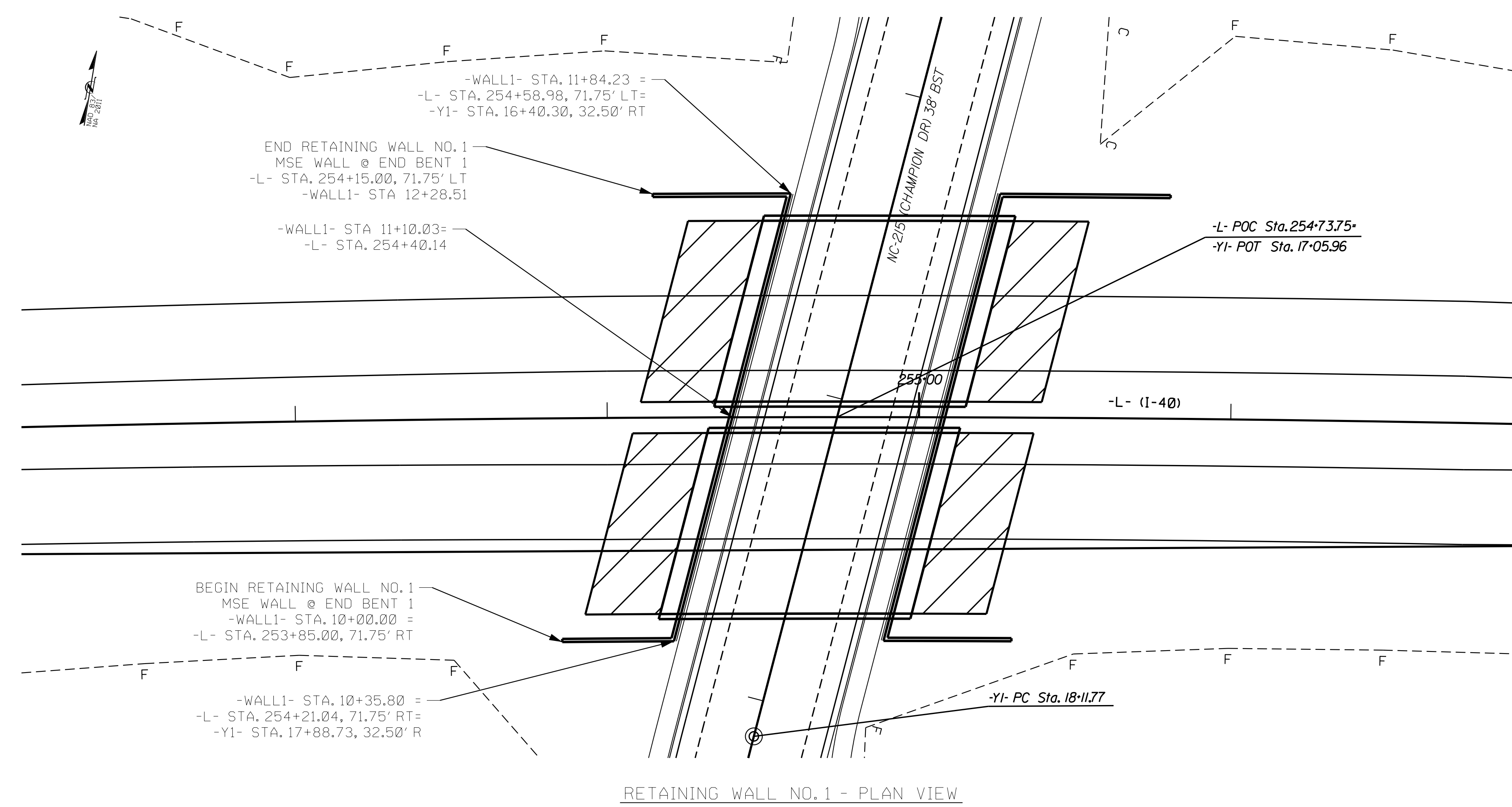
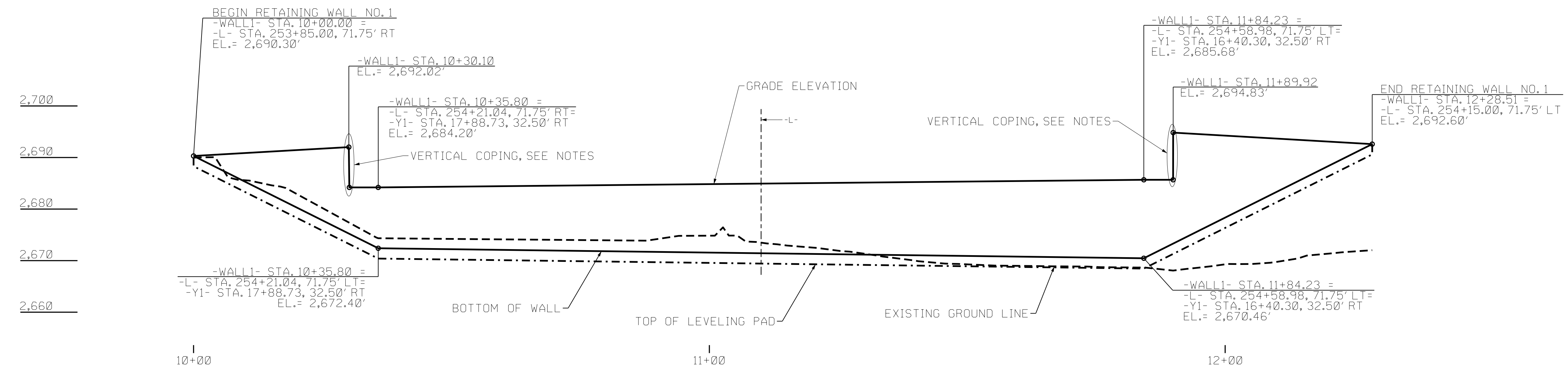

ESTIMATED MSE WALL QUANTITY	
RETAINING WALL NO. 1	•3,470 SQUARE FEET
* WALL AREA IS MEASURED USING THE DESIGN HEIGHT 'H'	

RETAINING WALL NO. 1 - PLAN VIEW



RETAINING WALL NO. 1 - ENVELOPE
 THE WALL ENVELOPE DOES NOT ACCURATELY DEPICT THE ACTUAL FACE OF THE WALL

PROJECT NO.: 55041.1.1 (HB-0004)
 HAYWOOD COUNTY
 STATION: -L- STA. 254+40.14
 SHEET 1 OF 5

PREPARED BY: MHS DATE: 1/24
 REVIEWED BY: ENW/SCC DATE: 1/24

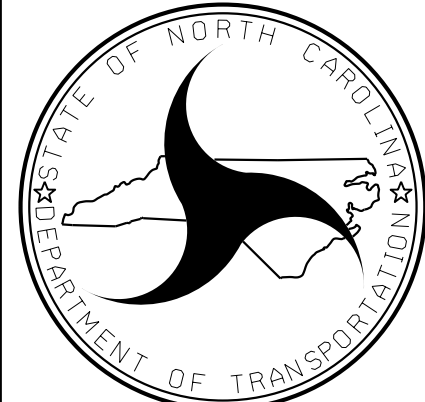
 NORTH CAROLINA
 DEPARTMENT OF TRANSPORTATION
 DIVISION OF HIGHWAYS
 GEOTECHNICAL
 ENGINEERING UNIT

REVISIONS						SHEET NO. W-1
NO.	BY	DATE	NO.	BY	DATE	
1			3			
2			4			

GEOTECHNICAL ENGINEER

ENGINEER

Designed by: *M.H. Stephens* 01/03/2024

SIGNATURE DATE SIGNATURE DATE

DOCUMENT NOT CONSIDERED FINAL UNLESS ALL SIGNATURES COMPLETED

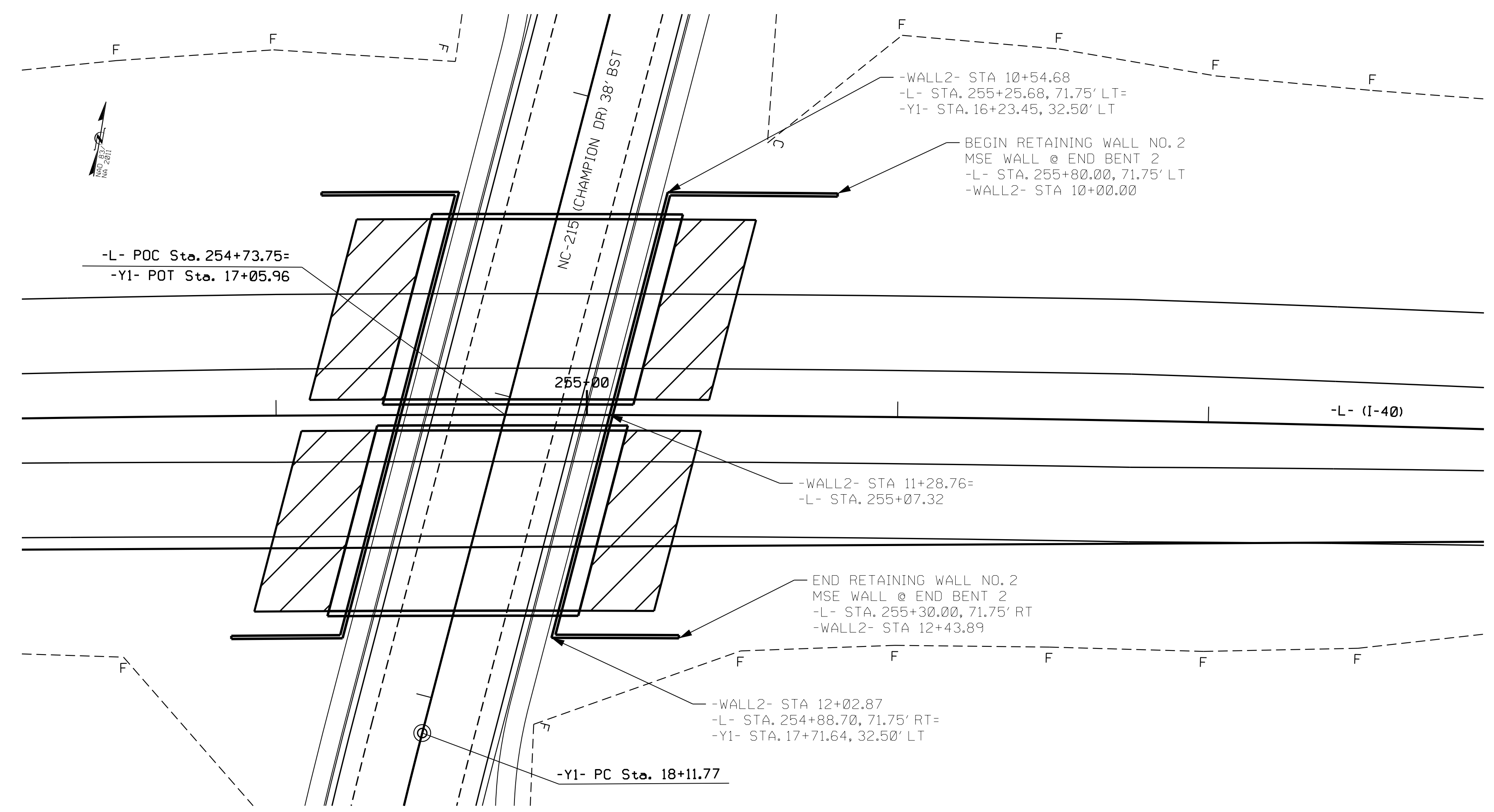

RETAINING WALL NO. 2 - PLAN VIEW

ESTIMATED MSE WALL QUANTITY	
RETAINING WALL NO. 2	•3,560 SQUARE FEET

• WALL AREA IS MEASURED USING THE DESIGN HEIGHT 'H'

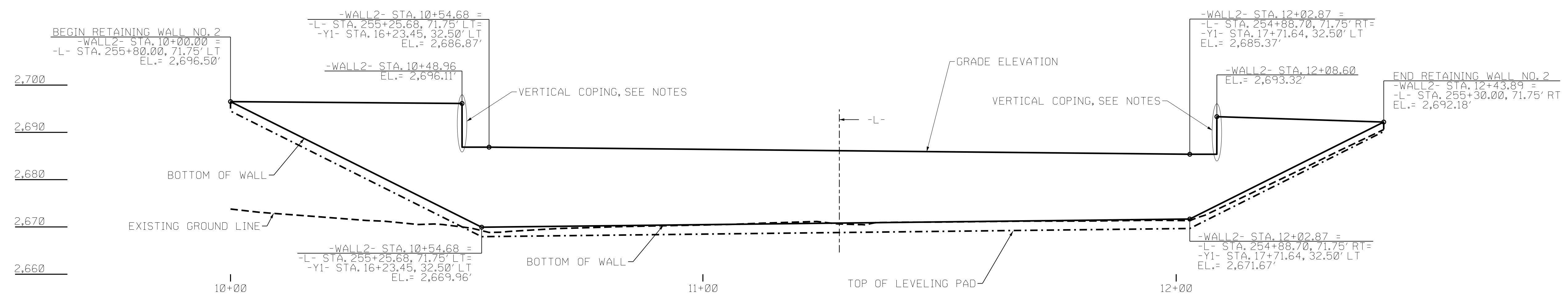

RETAINING WALL NO. 2 - ENVELOPE
THE WALL ENVELOPE DOES NOT ACCURATELY DEPICT THE ACTUAL FACE OF THE WALL

PROJECT NO.: 55041.1.1 (HB-0004)
HAYWOOD COUNTY
STATION: -L- STA. 255+07.32
SHEET 2 OF 5

PREPARED BY: MHS DATE: 1/24
REVIEWED BY: ENW/SCC DATE: 1/24

NORTH CAROLINA DEPARTMENT OF TRANSPORTATION DIVISION OF HIGHWAYS

GEOTECHNICAL ENGINEERING UNIT

REVISIONS					
NO.	BY	DATE	NO.	BY	DATE
1			3		
2			4		

SHEET NO. W-2

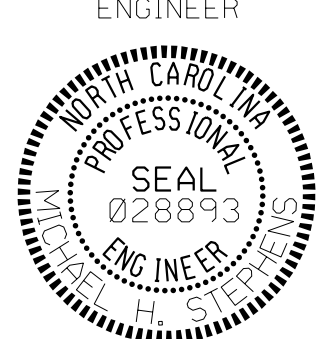
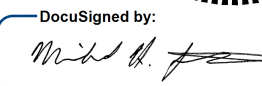
GEOTECHNICAL ENGINEER  SEAL 028893 MICHAEL H. STEPHENS ENGINEER	ENGINEER
DocuSigned by:  C447682092314CC... SIGNATURE	01/03/2024 DATE
DOCUMENT NOT CONSIDERED FINAL UNLESS ALL SIGNATURES COMPLETED	

NOTES:

FOR MECHANICALLY STABILIZED EARTH (MSE) RETAINING WALLS, SEE MECHANICALLY STABILIZED EARTH RETAINING WALLS PROVISION.
 FOR TYPE 2 REINFORCED BRIDGE APPROACH FILL, SEE BRIDGE APPROACH FILLS PROVISION AND ROADWAY DETAIL DRAWING NO. 423.03.
 FOR STEEL BEAM GUARDRAIL, SEE ROADWAY PLANS AND SECTION 862 OF THE STANDARD SPECIFICATIONS.
 FOR SINGLE FACED PRECAST CONCRETE BARRIER, SEE ROADWAY PLANS AND SECTION 857 OF THE STANDARD SPECIFICATIONS.
 AT THE CONTRACTOR'S OPTION, USE FINE AGGREGATE IN THE REINFORCED ZONE OF RETAINING WALL NOS 1 AND 2.
 A SEPARATION GEOTEXTILE IS REQUIRED AT THE BACK OF THE REINFORCED ZONE FOR RETAINING WALL NOS.1 AND 2.
 A DRAIN IS REQUIRED FOR RETAINING WALL NOS.1 AND 2.

BEFORE BEGINNING MSE WALL DESIGN FOR RETAINING WALL NOS.1 AND 2, SURVEY WALL LOCATION AND SUBMIT A REVISED WALL PROFILE VIEW (WALL ENVELOPE) FOR REVIEW. DO NOT START WALL DESIGN OR CONSTRUCTION UNTIL THE REVISED WALL ENVELOPE IS ACCEPTED.

DESIGN RETAINING WALL NOS.1 AND 2 FOR THE FOLLOWING:
 1) DESIGN HEIGHT (H) = WALL HEIGHT + WALL EMBEDMENT
 2) DESIGN LIFE = 100 YEARS
 3) MAXIMUM FACTORED VERTICAL PRESSURE ON FOUNDATION MATERIAL = 5,100 PSF
 4) MINIMUM REINFORCEMENT LENGTH (L) = 0.8H OR 6 FT, WHICHEVER IS LONGER
 5) MINIMUM EMBEDMENT DEPTH = VARIES (SEE EMBEDMENT TABLE)
 6) REINFORCED ZONE AGGREGATE PARAMETERS:

AGGREGATE TYPE*	UNIT WEIGHT (g) PCF	FRICTION ANGLE (f) DEGREES	COHESION (c) PSF
COARSE	110	38	0
FINE	115	34	0

*SEE MSE RETAINING WALLS PROVISION FOR COARSE AND FINE AGGREGATE MATERIAL REQUIREMENTS.

7) IN-SITU ASSUMED MATERIAL PARAMETERS:

MATERIAL TYPE	UNIT WEIGHT (g) PCF	FRICTION ANGLE (f) DEGREES	COHESION (c) PSF
RETAINED	120	30	0
FOUNDATION	115	30	0

THE WALL SITE FOR RETAINING WALL NOS.1 AND 2 LOCATED AT END BENT NOS.1 AND 2 IS CLASSIFIED AS AASHTO SITE CLASS D.
 DESIGN RETAINING WALL NOS.1 AND 2 FOR A LIVE LOAD (TRAFFIC) SURCHARGE.

DESIGN REINFORCEMENT CONNECTED TO END BENT CAPS FOR FACTORED LOAD AND LENGTH OF REINFORCEMENT IN ACTIVE ZONE (L) SHOWN. CAST REINFORCEMENT OR CONNECTORS INTO CAP BACKWALL FOR END BENT NO.1 LOCATION AT STATION 254+40.55 -L- AND END BENT NO.2 LOCATED AT STATION 255+21.00 -L-. MAINTAIN A CLEARANCE OF AT LEAST 3" BETWEEN REINFORCEMENT OR CONNECTORS AND REINFORCING STEEL IN CAP.

FOUNDATIONS FOR SIGNS, LIGHTING, AND/OR SIGNALS MAY BE LOCATED BEHIND RETAINING WALL NOS.1 AND 2 AND MAY INTERFERE WITH REINFORCEMENT. BEFORE BEGINNING MSE WALL CONSTRUCTION, SUBMIT PROPOSED CONSTRUCTION METHODS FOR THESE FOUNDATIONS FOR APPROVAL.

EXISTING OR FUTURE OBSTRUCTIONS SUCH AS FOUNDATIONS, GUARDRAIL, FENCE OR HANDRAIL POSTS, PAVEMENTS, PIPES, INLETS OR UTILITIES MAY INTERFERE WITH REINFORCEMENT FOR RETAINING WALL NOS.1 AND 2.

FOUNDATIONS FOR END BENT NO.1 LOCATED AT STATION 254+40.55 -L- AND END BENT NO.2 LOCATED AT STATION 255+21.00 -L- MAY INTERFERE WITH REINFORCEMENT FOR RETAINING WALL NOS 1 AND 2. SEE "FOUNDATION LAYOUT" SHEET FOR FOUNDATION LOCATIONS.

DO NOT PLACE LEVELING PAD CONCRETE, AGGREGATE OR REINFORCEMENT FOR RETAINING WALL NOS.1 AND 2 UNTIL EXCAVATION DIMENSIONS AND FOUNDATION MATERIAL ARE APPROVED.

VERTICAL COPING IS REQUIRED AT LOCATIONS IDENTIFIED ON WALL ENVELOPES.

WALL EMBEDMENT		
SLOPE IN FRONT OF STRUCTURES		MINIMUM EMBEDMENT DEPTH
HORIZONTAL	FOR WALLS	H/20
	FOR ABUTMENTS	H/10
3.0H:1.0V	WALLS	H/10
2.5H:1.0V	WALLS	H/8.5
2.0H:1.0V	WALLS	H/7
1.5H:1.0V	WALLS	H/5
1.25H:1.0V	WALLS	H/4
1.0H:1.0V	WALLS	H/3

NOTE:
 1) MAINTAIN A MINIMUM BENCH WIDTH OF 4.0 IN FRONT OF THE WALL FOR ITS ENTIRE LENGTH.
 2) MINIMUM EMBEDMENT DEPTH OF 2 FT, UNLESS LARGER DEPTHS DICTATED BY THE ABOVE TABLE.
 3) MAXIMUM SLOPE OF 1H:1V WILL BE MAINTAINED ON FRONT SLOPES FOR THE ENTIRE LENGTH OF THE WALL.
 4) SUBMIT WITH THE WALL DESIGN INTERNAL, EXTERNAL, AND GLOBAL STABILITY ANALYSES.

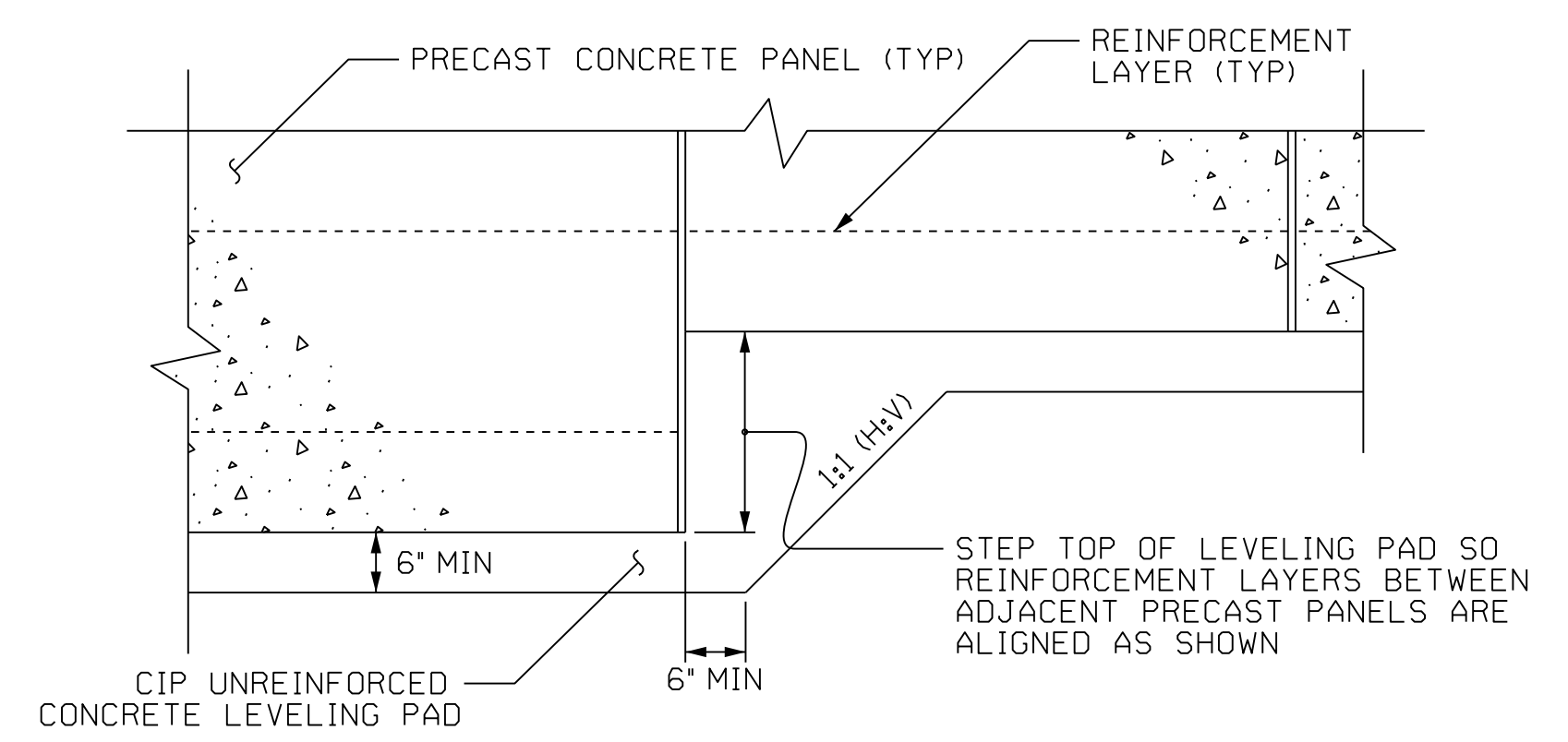

**PRECAST PANELS
LEVELING PAD STEP DETAIL**

PROJECT NO.: 55041.1.1 (HB-0004)
 HAYWOOD COUNTY
 STATION:
 SHEET 5 OF 5

PREPARED BY: MHS	DATE: 1/24
REVIEWED BY: ENW/SCC	DATE: 1/24

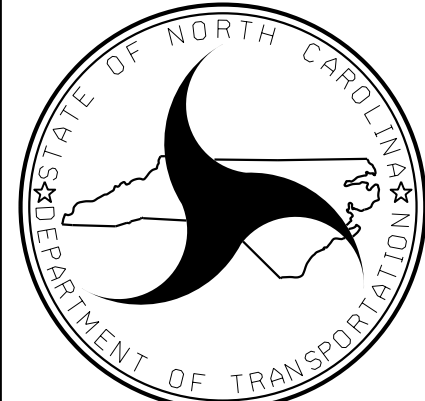

NORTH CAROLINA
DEPARTMENT OF TRANSPORTATION
DIVISION OF HIGHWAYS

GEOTECHNICAL
ENGINEERING UNIT

MSE RETAINING WALL NOS.
1 AND 2,
NOTES AND DETAILS

REVISIONS					
NO.	BY	DATE	NO.	BY	DATE
1			3		
2			4		

SHEET NO. W-5

GEOTECHNICAL ENGINEER

ENGINEER

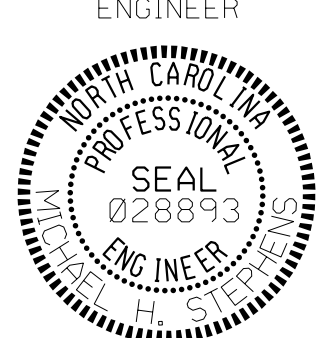

DocuSigned by: *M.H.S.* 01/03/2024

**DOCUMENT NOT CONSIDERED FINAL
UNLESS ALL SIGNATURES COMPLETED**

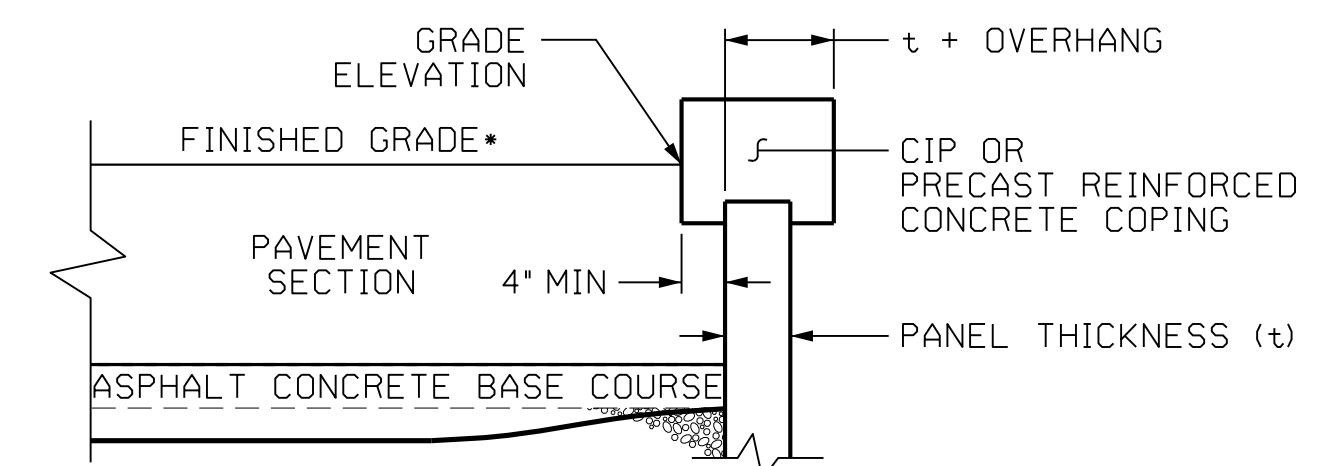
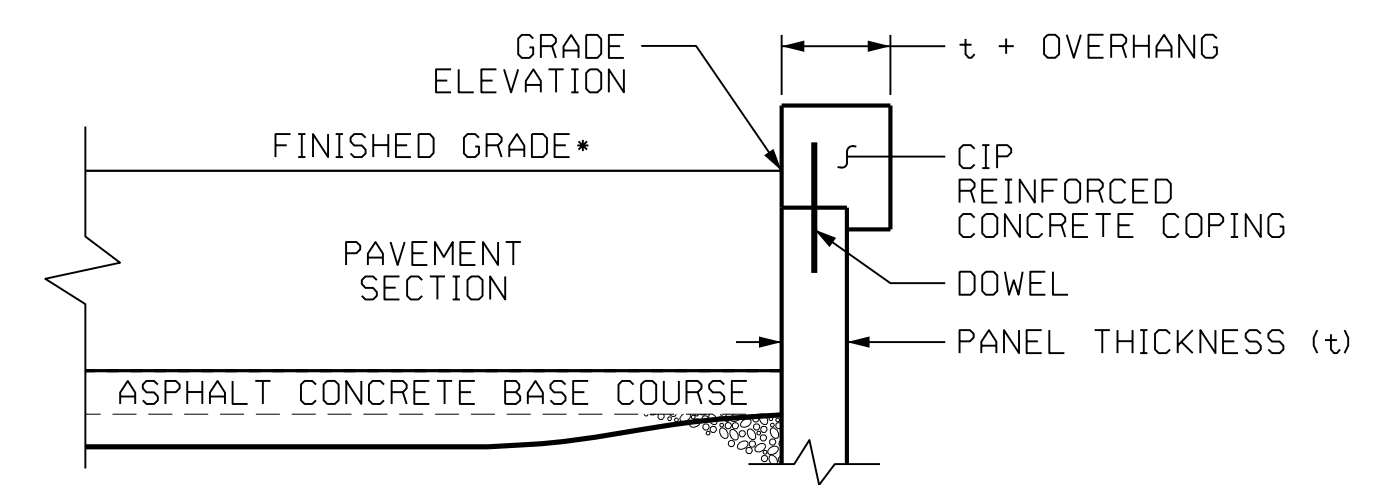
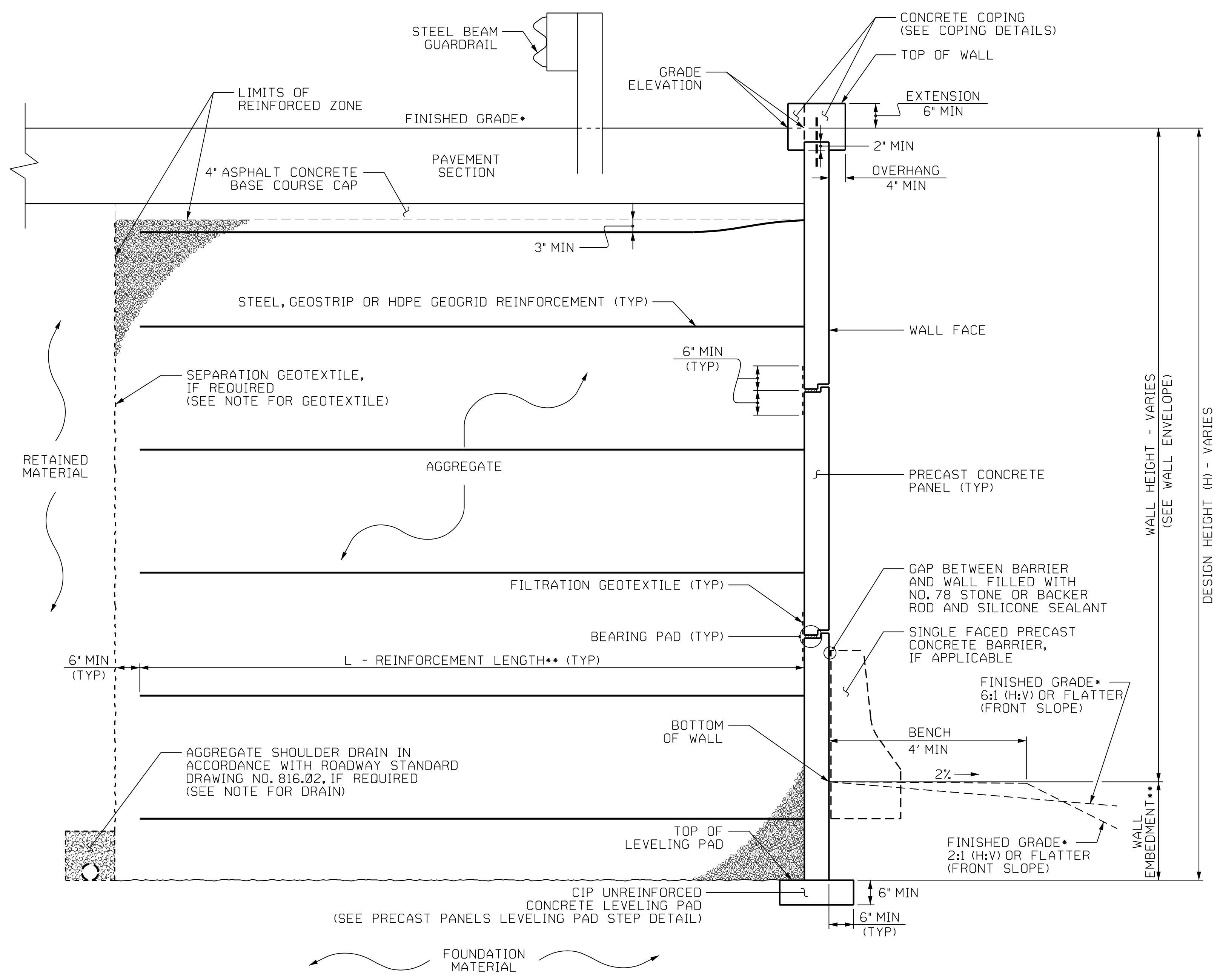

COPING DETAILS

AT THE CONTRACTOR'S OPTION, CONNECT COPING TO PANELS WITH DOWELS OR EXTEND COPING DOWN BACK OF PANELS.
*SEE ROADWAY PLANS FOR FINISHED GRADE DETAILS.

MSE WALL WITH PRECAST PANELS - TYPICAL SECTION

*SEE ROADWAY PLANS FOR FINISHED GRADE DETAILS.
**SEE MSE RETAINING WALLS PROVISION AND IF APPLICABLE, MSE WALL NOTES FOR WALL EMBEDMENT AND REINFORCEMENT LENGTH REQUIREMENTS.

PROJECT NO.: 55041.1.1 (HB-0004)
 HAYWOOD COUNTY
 STATION: _____
 SHEET 4 OF 5

PREPARED BY: MHS	DATE: 1/24
REVIEWED BY: ENW/SCC	DATE: 1/24

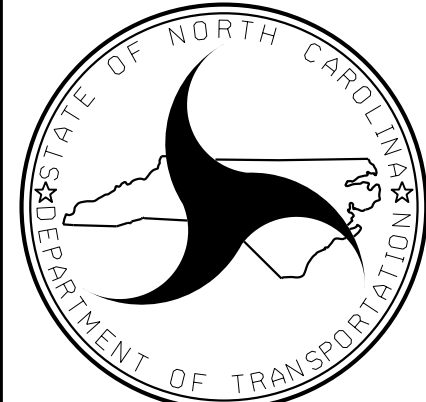

NORTH CAROLINA
DEPARTMENT OF TRANSPORTATION
DIVISION OF HIGHWAYS

GEOTECHNICAL
ENGINEERING UNIT

REVISIONS						SHEET NO.
NO.	BY	DATE	NO.	BY	DATE	
1			3			W-4
2			4			

GEOTECHNICAL ENGINEER

ENGINEER

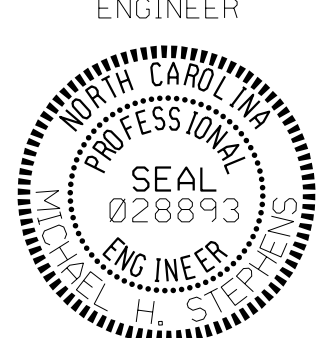

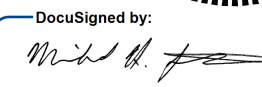
DocuSigned by:
 01/03/2024

SIGNATURE DATE SIGNATURE DATE

**DOCUMENT NOT CONSIDERED FINAL
UNLESS ALL SIGNATURES COMPLETED**

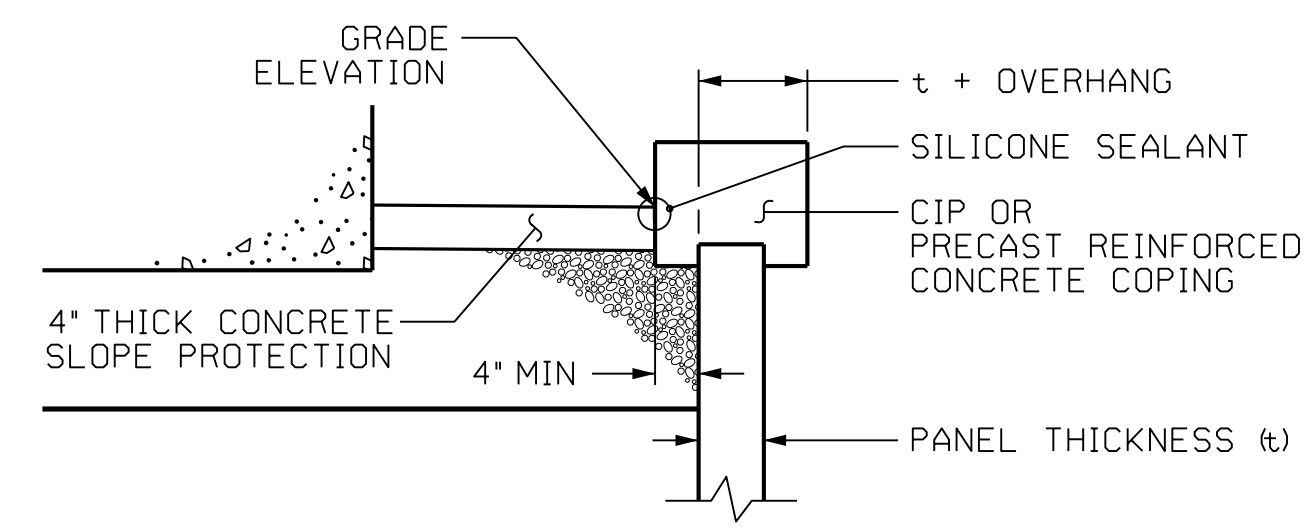
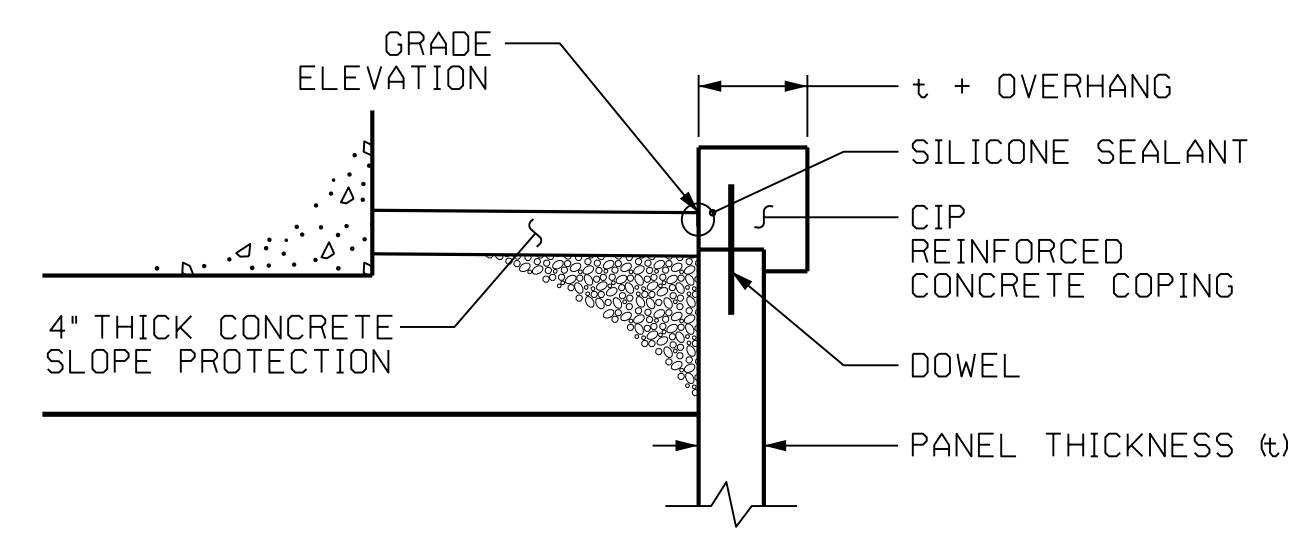
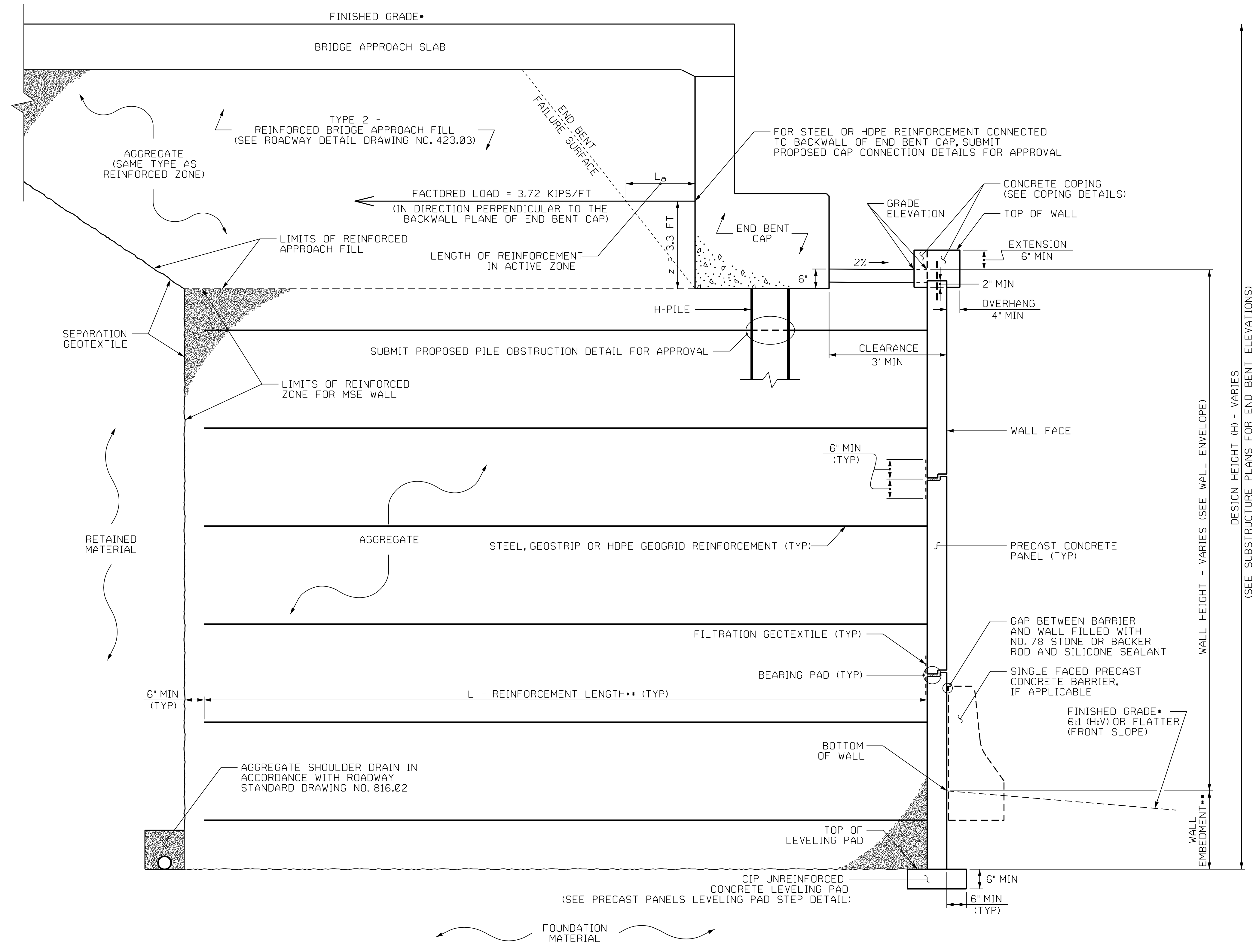

COPING DETAILS

AT THE CONTRACTOR'S OPTION, CONNECT COPING TO PANELS WITH DOWELS OR EXTEND COPING DOWN BACK OF PANELS.

MSE ABUTMENT WALL WITH PRECAST PANELS - TYPICAL SECTION

•SEE ROADWAY PLANS FOR FINISHED GRADE DETAILS.
 ••SEE MSE RETAINING WALLS PROVISION AND IF APPLICABLE,
 MSE WALL NOTES FOR WALL EMBEDMENT AND REINFORCEMENT LENGTH REQUIREMENTS.

PROJECT NO.: 55041.1:1 (HB-0004)
 HAYWOOD COUNTY
 STATION:
 SHEET 3 OF 5

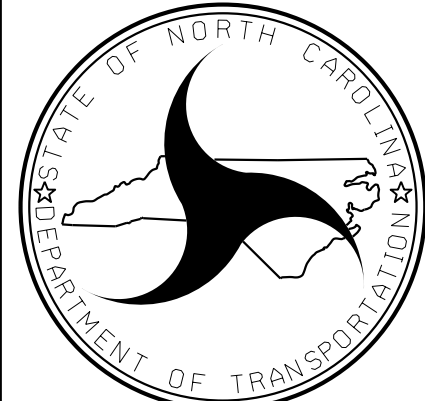

NORTH CAROLINA
DEPARTMENT OF TRANSPORTATION
DIVISION OF HIGHWAYS

GEOTECHNICAL
ENGINEERING UNIT

MSE RETAINING WALL NOS.
1 AND 2, TYPICAL SECTION
AND DETAILS

REVISIONS					
NO.	BY	DATE	NO.	BY	DATE
1			3		
2			4		

PREPARED BY: MHS	DATE: 1/24
REVIEWED BY: ENW/SCC	DATE: 1/24

SHEET NO.
W-3