

NOTES

ALL PRESTRESSING STRANDS SHALL BE 7-WIRE LOW-RELAXATION GRADE 270 STRANDS AND SHALL CONFORM TO AASHTO M203 EXCEPT FOR SAMPLING REQUIREMENTS WHICH SHALL BE IN ACCORDANCE WITH THE STANDARD SPECIFICATIONS.

ALL REINFORCING STEEL SHALL BE GRADE 60.

APPLY EPOXY PROTECTIVE COATING TO END OF GIRDER SURFACES INDICATED IN ELEVATION VIEW.

EMBEDDED PLATE "B-1" SHALL BE GALVANIZED IN ACCORDANCE WITH THE STANDARD SPECIFICATIONS.

ANCHOR STUDS SHALL CONFORM TO AASHTO M169 GRADES 1010 THROUGH 1020 OR APPROVED EQUAL, AND SHALL MEET THE TYPE "B" REQUIREMENTS OF SUBSECTION 7.3 OF THE ANSI/AASHTO/AWS D1.5 BRIDGE WELDING CODE.

THE TRANSFER OF LOAD FROM THE ANCHORAGES TO THE GIRDER SHALL BE DONE WHEN CONCRETE HAS REACHED A COMPRESSIVE STRENGTH OF NOT LESS THAN 6,000 PSI.

DEPENDING ON THE TYPE OF SYSTEM USED TO SUPPORT THE DECK SLAB FORMS, PRESET ANCHORS MAY BE NECESSARY IN THE PRESTRESSED CONCRETE GIRDER.

THE TOP SURFACE OF THE GIRDER, EXCLUDING THE OUTSIDE 4", SHALL BE RAKED TO A DEPTH OF 1/4".

THE CONTRACTOR HAS THE OPTION TO PROVIDE, AT NO ADDITIONAL COST TO THE DEPARTMENT, 2 ADDITIONAL STRANDS AT THE TOP OF THE GIRDER TO FACILITATE TYING OF THE REINFORCING STEEL. THESE STRANDS SHALL BE PULLED TO A LOAD OF 4500 lbs.

DEAD LOAD DEFLECTION TABLE FOR GIRDERS																					
0.6" Ø LOW RELAXATION	SPAN A																				
	GIRDERS 1 & 7																				
TWENTIETH POINTS	0	.050	.100	.150	.200	.250	.300	.350	.400	.450	.500	.550	.600	.650	.700	.750	.800	.850	.900	.950	0
CAMBER (GIRDER ALONE IN PLACE) ↑	0	0.036	0.072	0.096	0.121	0.138	0.155	0.165	0.175	0.178	0.181	0.178	0.175	0.165	0.155	0.138	0.121	0.096	0.072	0.036	0
* DEFLECTION DUE TO SUPERIMPOSED D.L. ↓	0	0.016	0.032	0.048	0.064	0.076	0.089	0.097	0.105	0.107	0.110	0.107	0.105	0.097	0.089	0.076	0.064	0.048	0.032	0.016	0
FINAL CAMBER ↑	0	1/4"	1/2"	9/16"	11/16"	3/4"	13/16"	13/16"	13/16"	7/8"	7/8"	7/8"	13/16"	13/16"	13/16"	3/4"	11/16"	9/16"	1/2"	1/4"	0

* INCLUDES FUTURE WEARING SURFACE
ALL VALUES ARE SHOWN IN FEET (DECIMAL FORM), EXCEPT "FINAL CAMBER", WHICH IS GIVEN IN INCHES (FRACTION FORM).

DEAD LOAD DEFLECTION TABLE FOR GIRDERS																					
0.6" Ø LOW RELAXATION	SPAN A																				
	GIRDERS 2 THRU 6																				
TWENTIETH POINTS	0	.050	.100	.150	.200	.250	.300	.350	.400	.450	.500	.550	.600	.650	.700	.750	.800	.850	.900	.950	0
CAMBER (GIRDER ALONE IN PLACE) ↑	0	0.036	0.072	0.096	0.121	0.138	0.155	0.165	0.175	0.178	0.181	0.178	0.175	0.165	0.155	0.138	0.121	0.096	0.072	0.036	0
* DEFLECTION DUE TO SUPERIMPOSED D.L. ↓	0	0.018	0.036	0.053	0.071	0.085	0.099	0.108	0.116	0.119	0.122	0.119	0.116	0.108	0.099	0.085	0.071	0.053	0.036	0.018	0
FINAL CAMBER ↑	0	3/16"	7/16"	1/2"	5/8"	5/8"	11/16"	11/16"	11/16"	11/16"	11/16"	11/16"	11/16"	11/16"	11/16"	5/8"	5/8"	1/2"	7/16"	3/16"	0

* INCLUDES FUTURE WEARING SURFACE
ALL VALUES ARE SHOWN IN FEET (DECIMAL FORM), EXCEPT "FINAL CAMBER", WHICH IS GIVEN IN INCHES (FRACTION FORM).

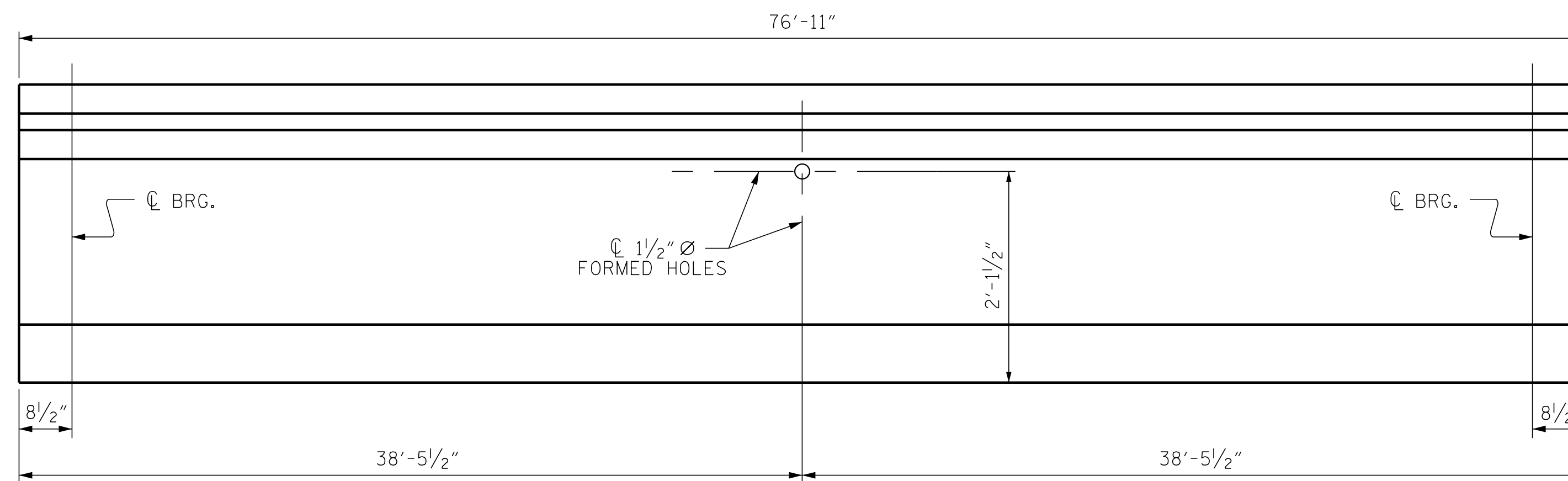

LOCATION OF BOLT HOLE IN GIRDERS

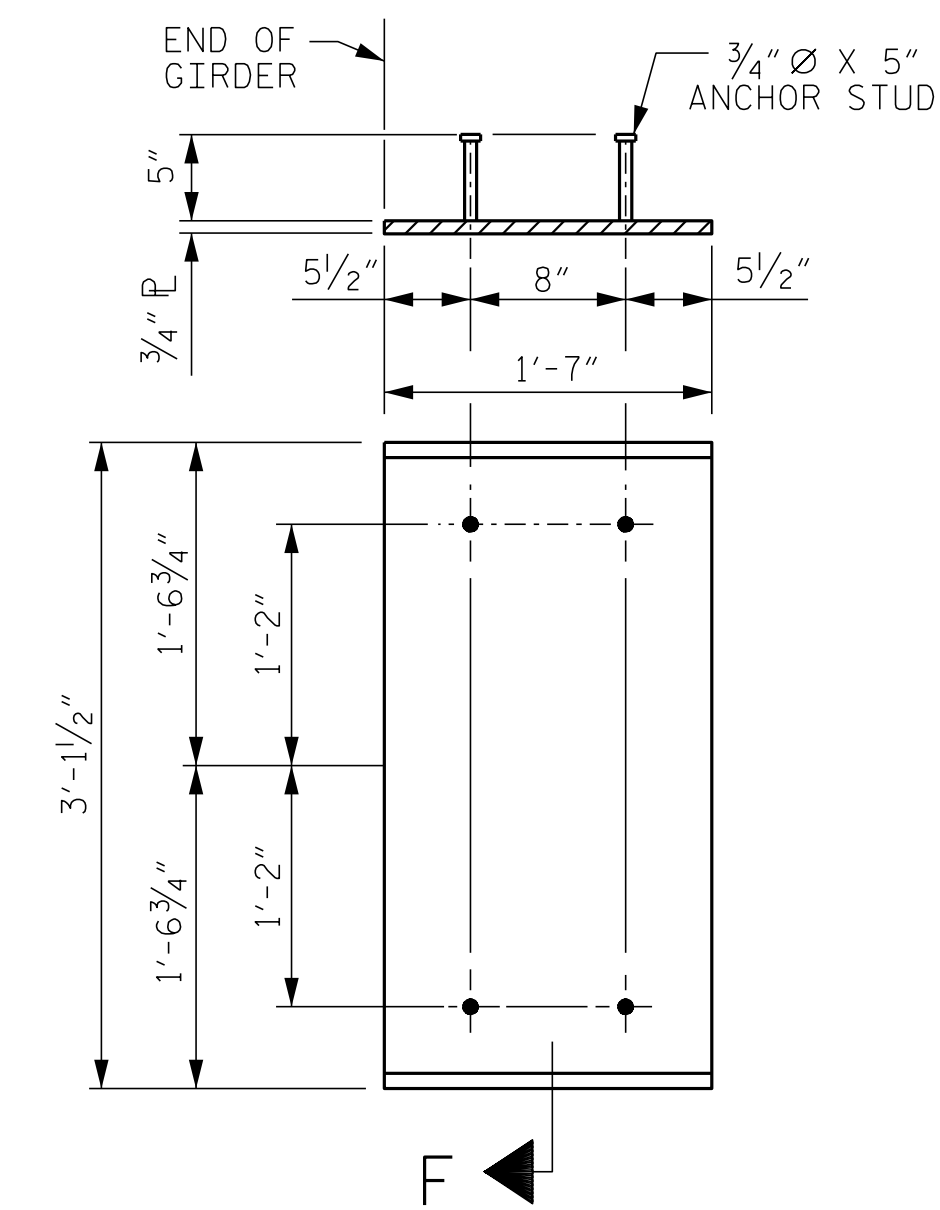

EMBEDDED PLATE "B-1" DETAILS FOR FIB GIRDER

(2 REQ'D PER GIRDER)

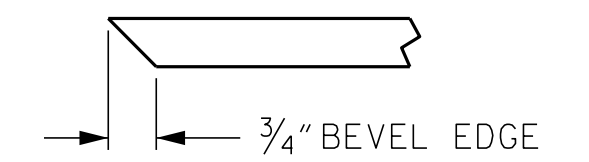

SECTION "F"

(SEE NOTES)

PROJECT NO. HB-0004
HAYWOOD COUNTY
STATION: 254+73.75 -L-

SHEET 3 OF 3

ASSEMBLED BY : D. HODGE DATE : 2/23
CHECKED BY : G. GILLAND DATE : 8/23
DRAWN BY : BNB 08/21
CHECKED BY : AAI 10/21

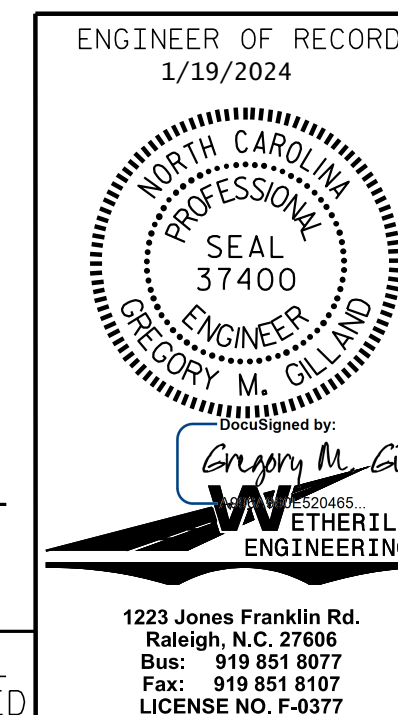

STATE OF NORTH CAROLINA
DEPARTMENT OF TRANSPORTATION
RALEIGH
STANDARD
FIB
DETAILS
(LEFT LANE)

REVISIONS						SHEET NO.
NO.	BY:	DATE:	NO.	BY:	DATE:	S1-13
1			3			TOTAL SHEETS 58
2			4			

DOCUMENT NOT CONSIDERED FINAL
UNLESS ALL SIGNATURES COMPLETED

1223 Jones Franklin Rd.
Raleigh, N.C. 27606
Bus: 919 851 8077
Fax: 919 851 8107
LICENSE NO. F-0377