

STAGE I

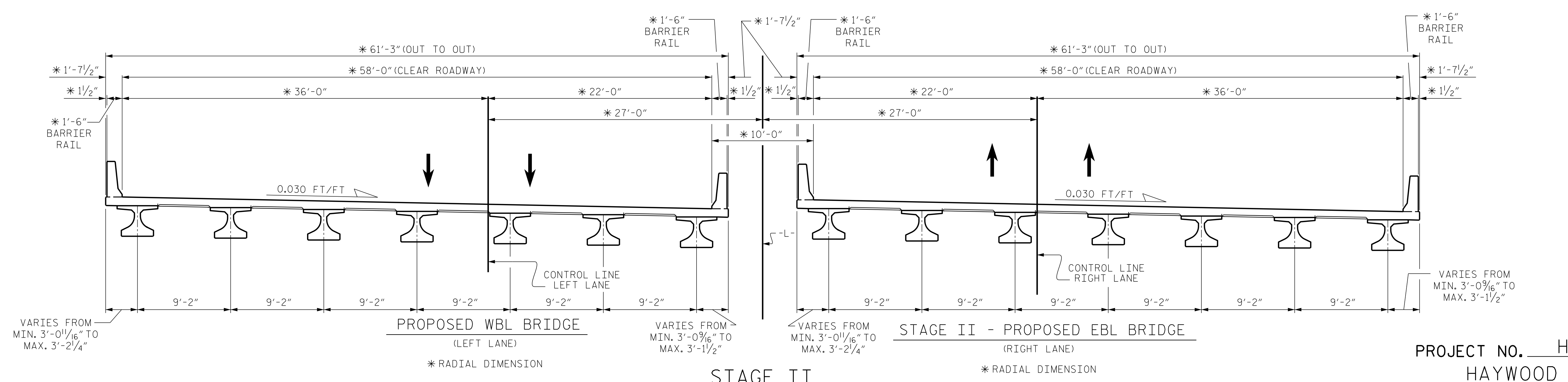

STAGE II

PROJECT NO. HB-0004
HAYWOOD COUNTY
 STATION: 254+73.75 -L-

P:\2023\2312401_HB-0004\Structures\DWG\HB-0004 (LEFT LANE)\HB0004-LEFT-COV-SEA.dgn
 1/18/2024 4:39:10 PM

DRAWN BY: D. HODGE DATE: 2/23
 CHECKED BY: J. DILWORTH DATE: 9/23

DOCUMENT NOT CONSIDERED FINAL
 UNLESS ALL SIGNATURES COMPLETED

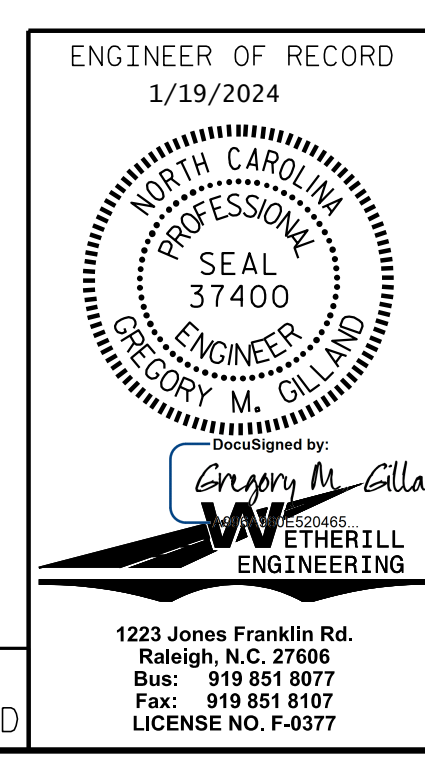

ENGINEER OF RECORD 1/19/2024		STATE OF NORTH CAROLINA DEPARTMENT OF TRANSPORTATION RALEIGH				
CONSTRUCTION SEQUENCE FOR BRIDGES ON I-40 OVER NC 215 BETWEEN SR 1513 AND SR 1585		REVISIONS				
		NO.	BY:	DATE:	NO.	BY:
1			3			
2			4			
SHEET NO. S1-07			TOTAL SHEETS 58			

1223 Jones Franklin Rd.
 Raleigh, N.C. 27606
 Bus: 919 851 8077
 Fax: 919 851 8107
 LICENSE NO. F-0377