

**WETHERILL ENGINEERING**  
 1223 Jones Franklin Rd.  
 Raleigh, N.C. 27606  
 License No. F-0377  
 Bus: 919 851 8077  
 Fax: 919 851 8107

TRANSPORTATION PLANNING/DESIGN - BRIDGE/STRUCTURE DESIGN  
 CIVIL/SITE DESIGN - GIS/GPS - SURVEY/SUE - UTILITIES - CONSTRUCTION OBSERVATION

PROJECT REFERENCE NO.	HB-0004	SHEET NO.	UC-3A
DESIGNED BY:	PKP	DATE	4/10/2024
DRAWN BY:	JDS		
CHECKED BY:	PKP		
APPROVED BY:	EGW		
REVISED:			
NORTH CAROLINA DEPARTMENT OF TRANSPORTATION		UTILITY CONSTRUCTION PLANS ONLY	
UTILITIES ENGINEERING SEC. PHONE: (919) 707-6690 FAX: (919) 250-4151			

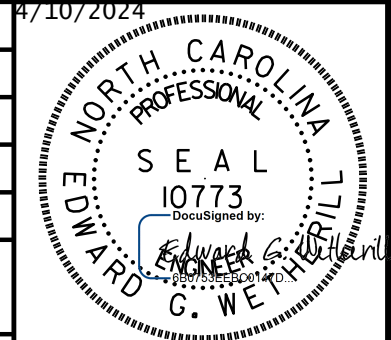

**DOCUMENT NOT CONSIDERED FINAL UNLESS ALL SIGNATURES COMPLETED**

**UTILITY CONSTRUCTION**

# PROJECT TYPICAL DETAILS

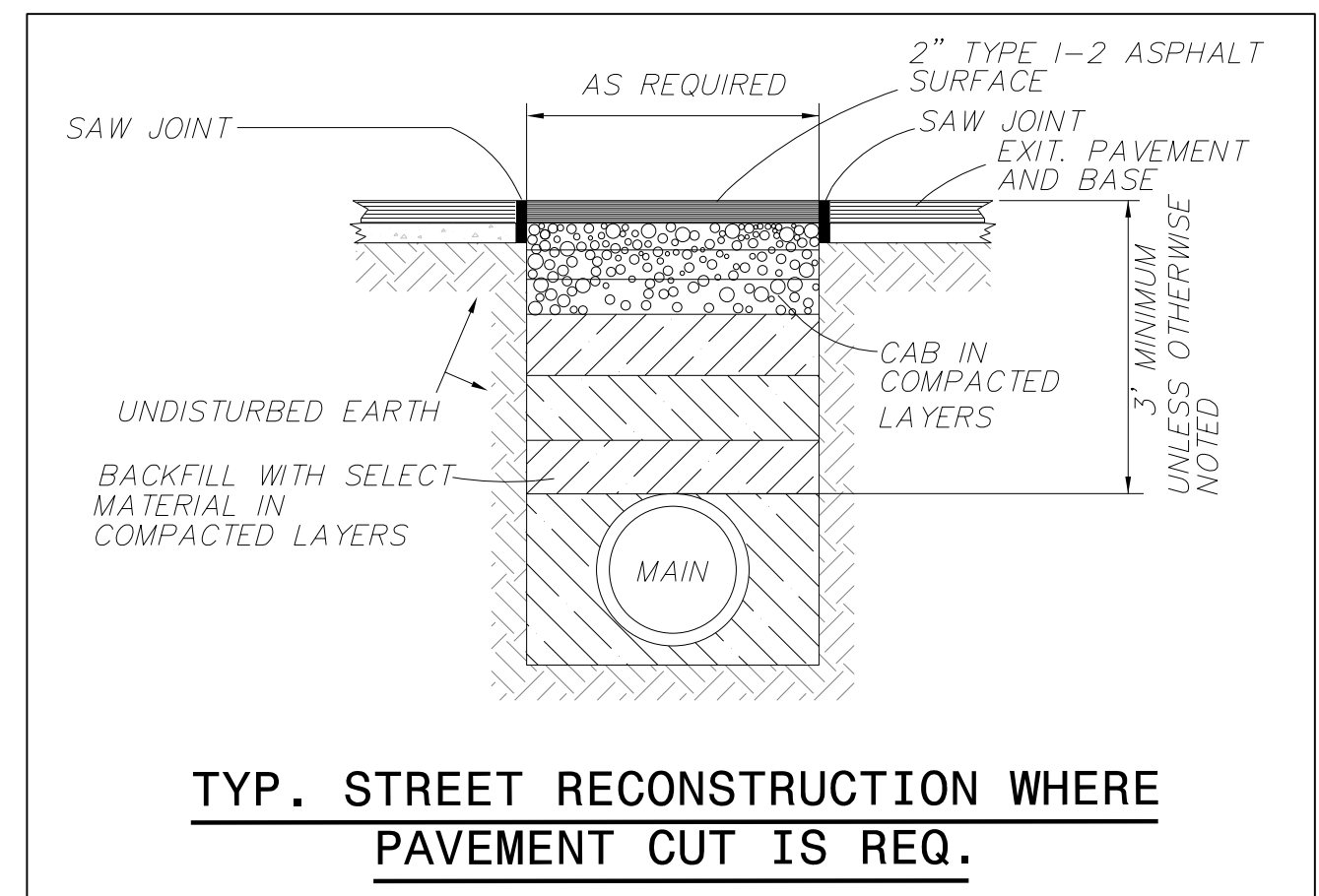
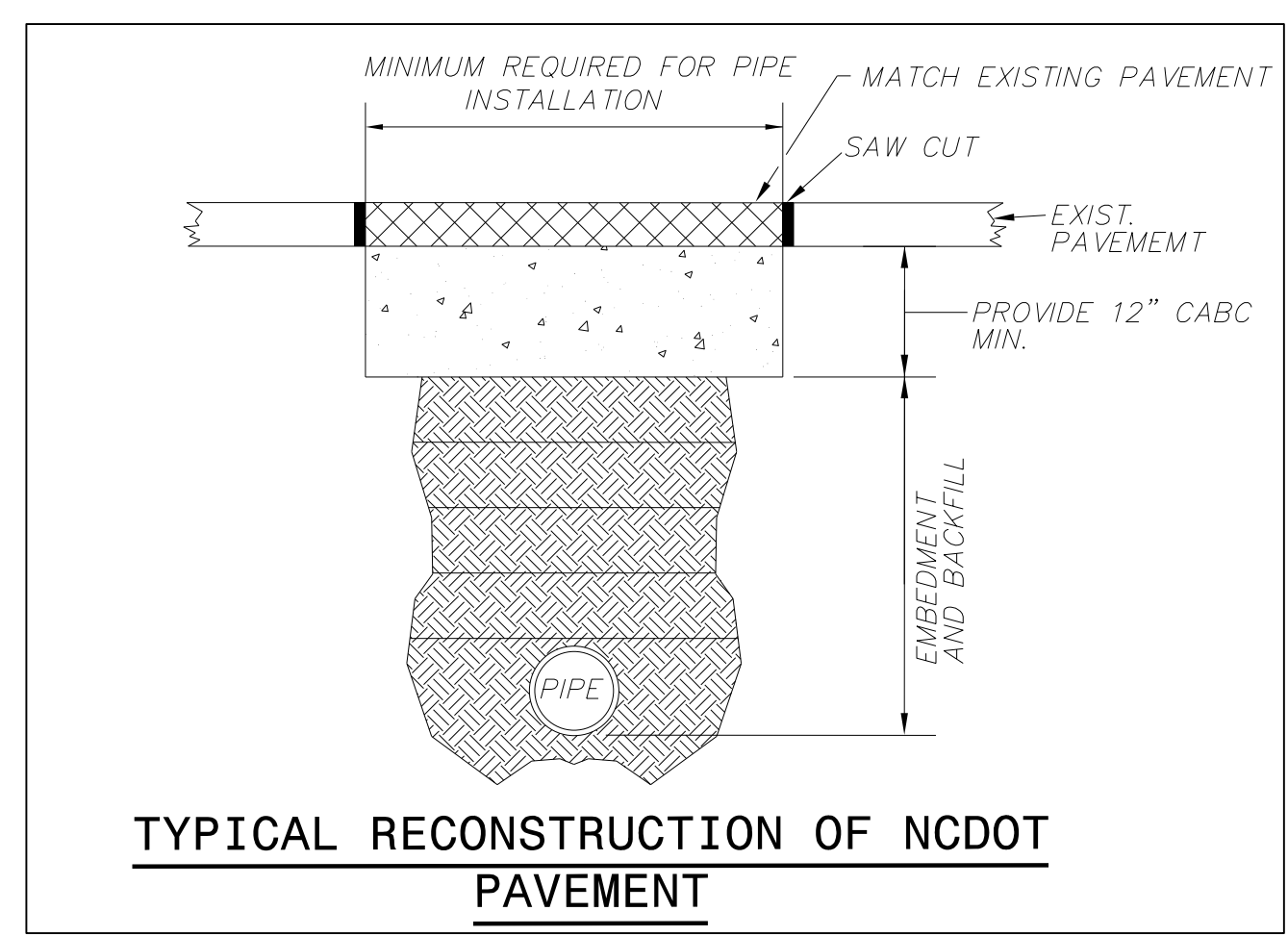
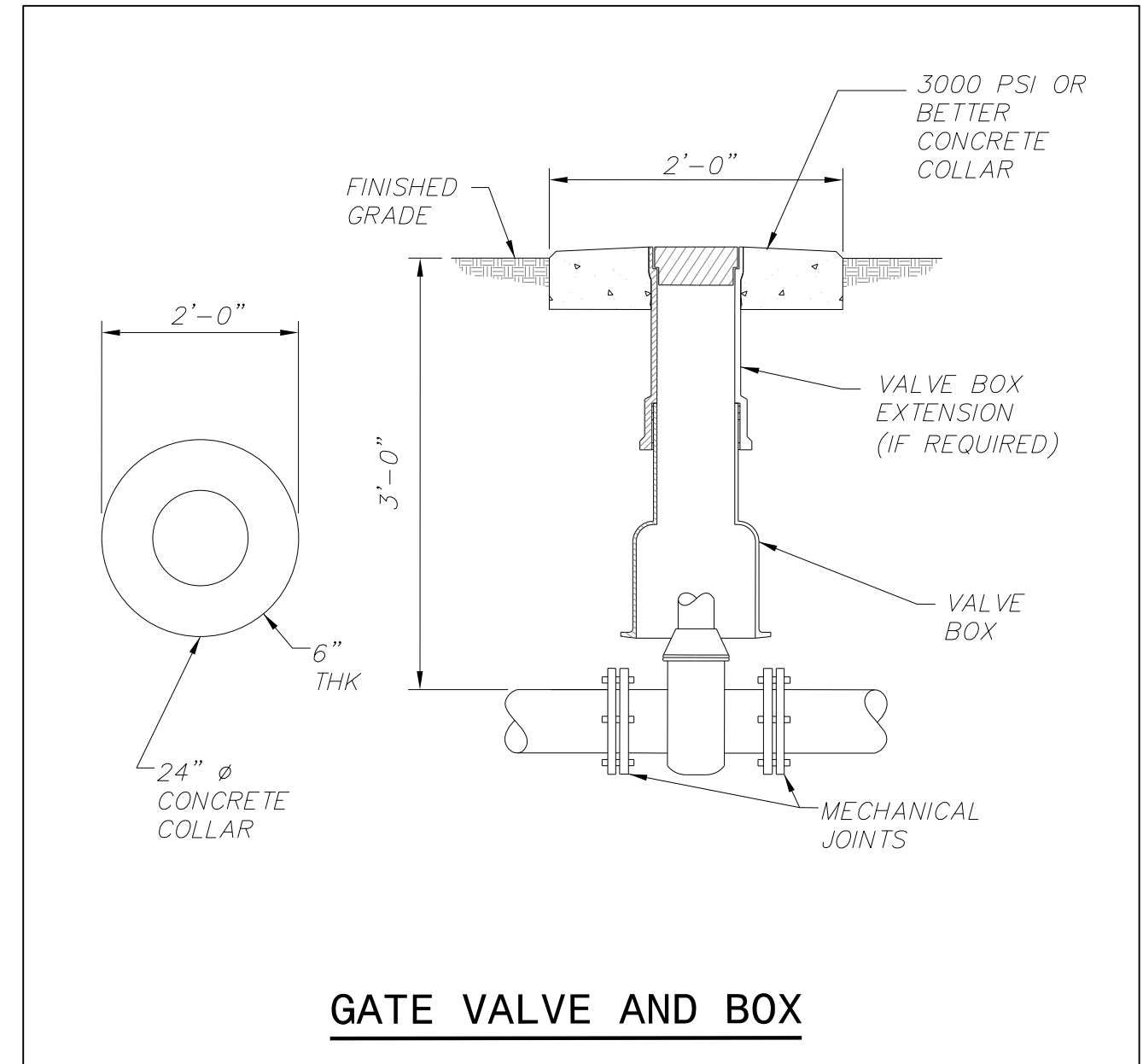
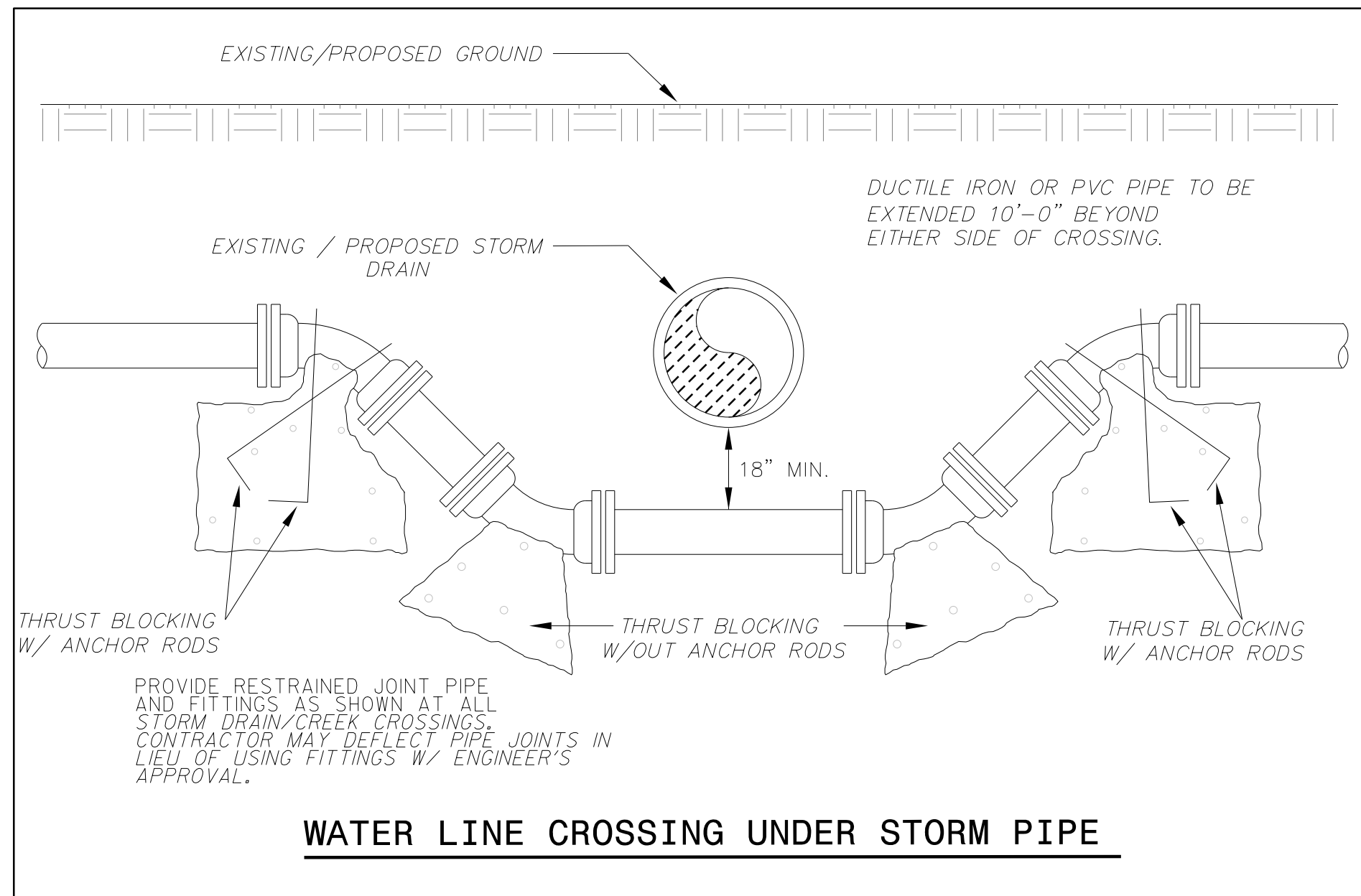

ROD REQUIREMENTS	
SERVICE SIZE	NO. OF RODS
4"	2
6"	2
8"	4
12"	8

**RESTRAINED TEE AND VALVE INSTALLATION**

**GENERAL NOTES**

- ONCE INSTALLED AND TIGHT, THE STEEL RODS AND BOLTS SHALL BE COATED WITH 2 COATS OF BITUMINOUS BASE PAINT.
- CONCRETE SHALL NOT CONTACT BOLTS OR ENDS OF MECHANICAL FITTINGS.

**STANDARD TAPPING SLEEVE AND VALVE ASSEMBLY**

**NOTES**

- CONCRETE SHALL NOT CONTACT BOLTS OR ENDS OF MECHANICAL JOINT FITTINGS.