

| | | | |
|---|--------|---------------------------------|-------|
| PROJECT REFERENCE NO. | P-5720 | SHEET NO. | UC-3C |
| DESIGNED BY: | DGB | | |
| DRAWN BY: | DGB | | |
| CHECKED BY: | ZGP | | |
| APPROVED BY: | NDR | | |
| REVISED: | | | |
| NORTH CAROLINA DEPARTMENT OF TRANSPORTATION | | UTILITY CONSTRUCTION PLANS ONLY | |

UTILITY CONSTRUCTION

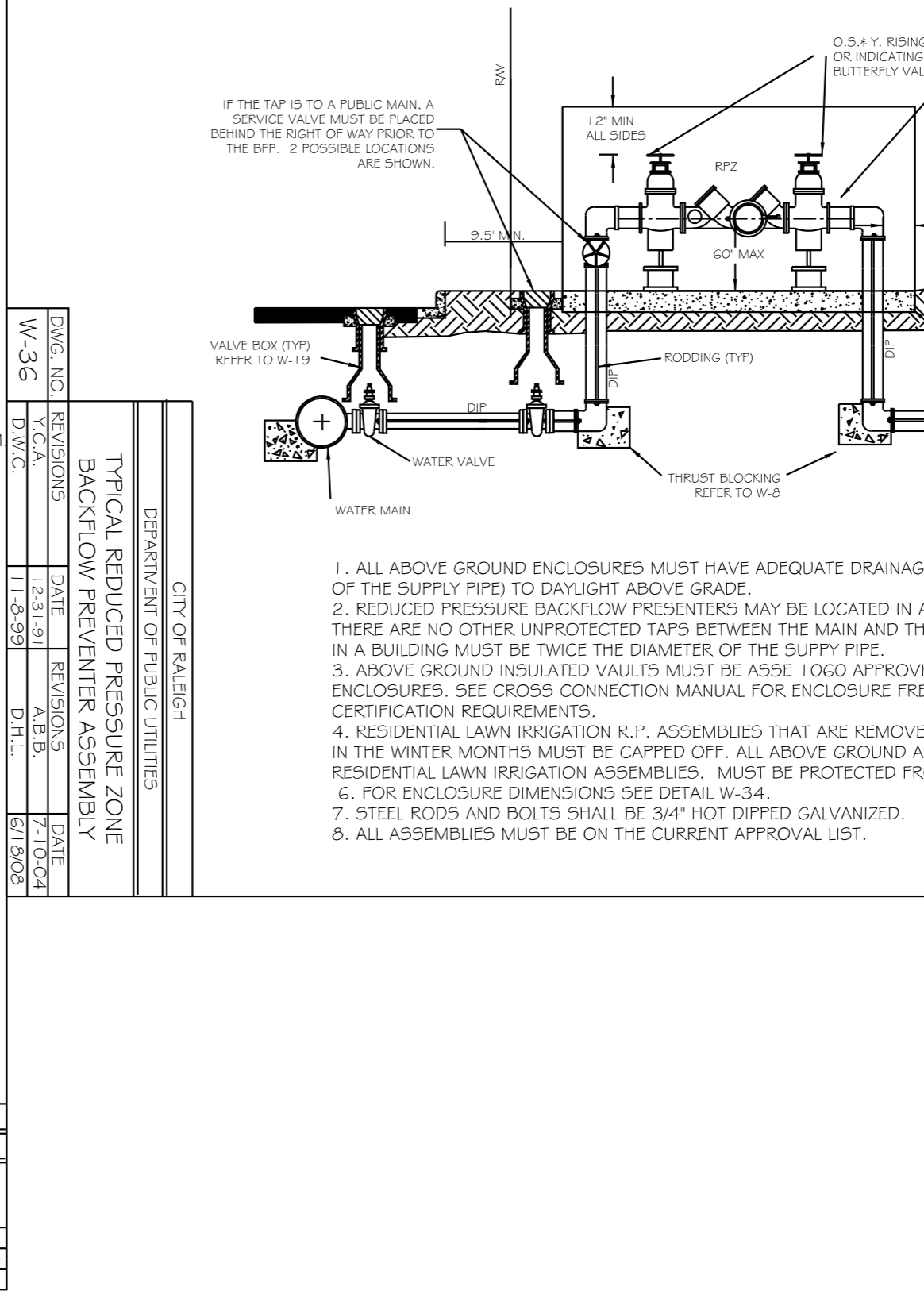
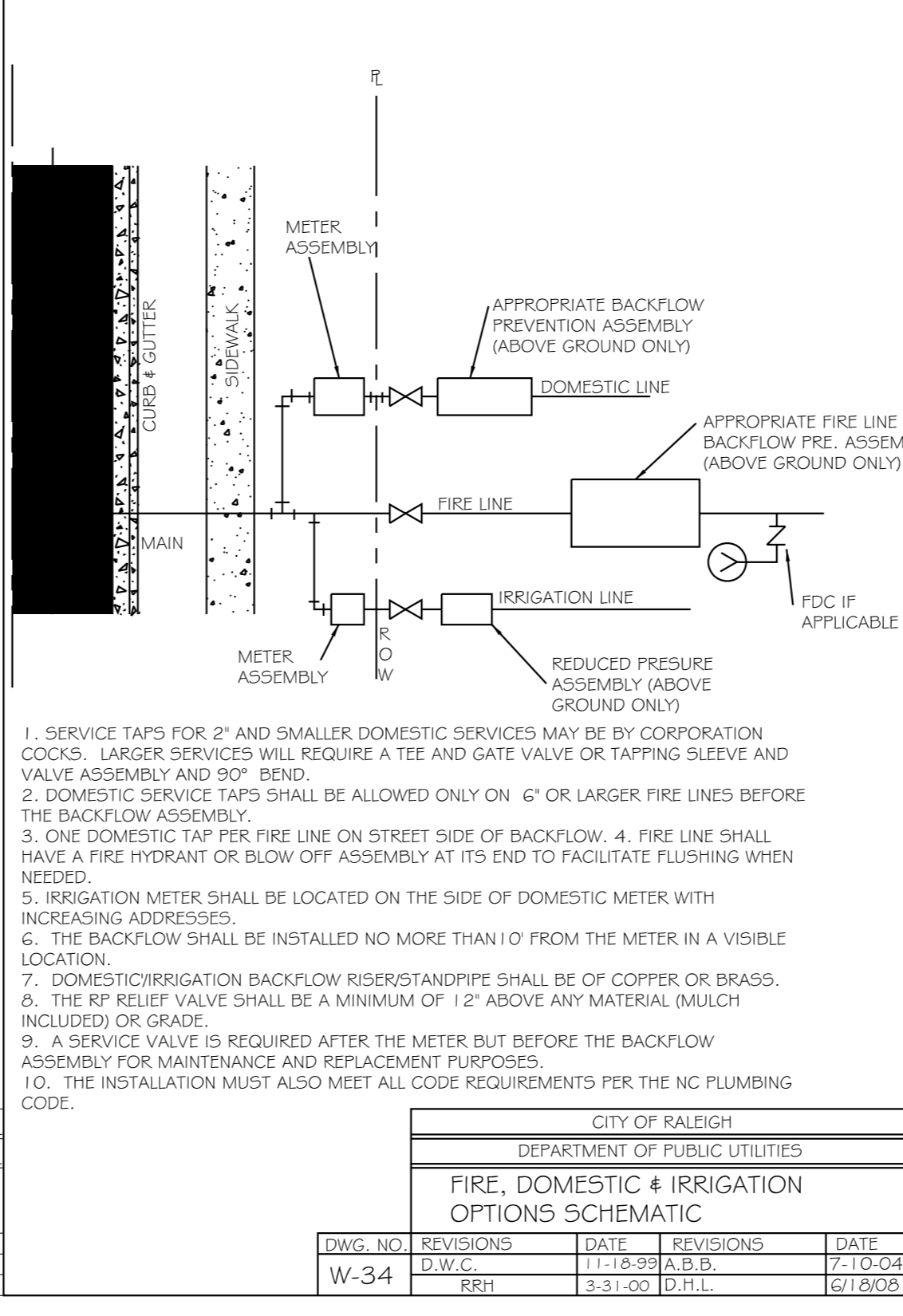
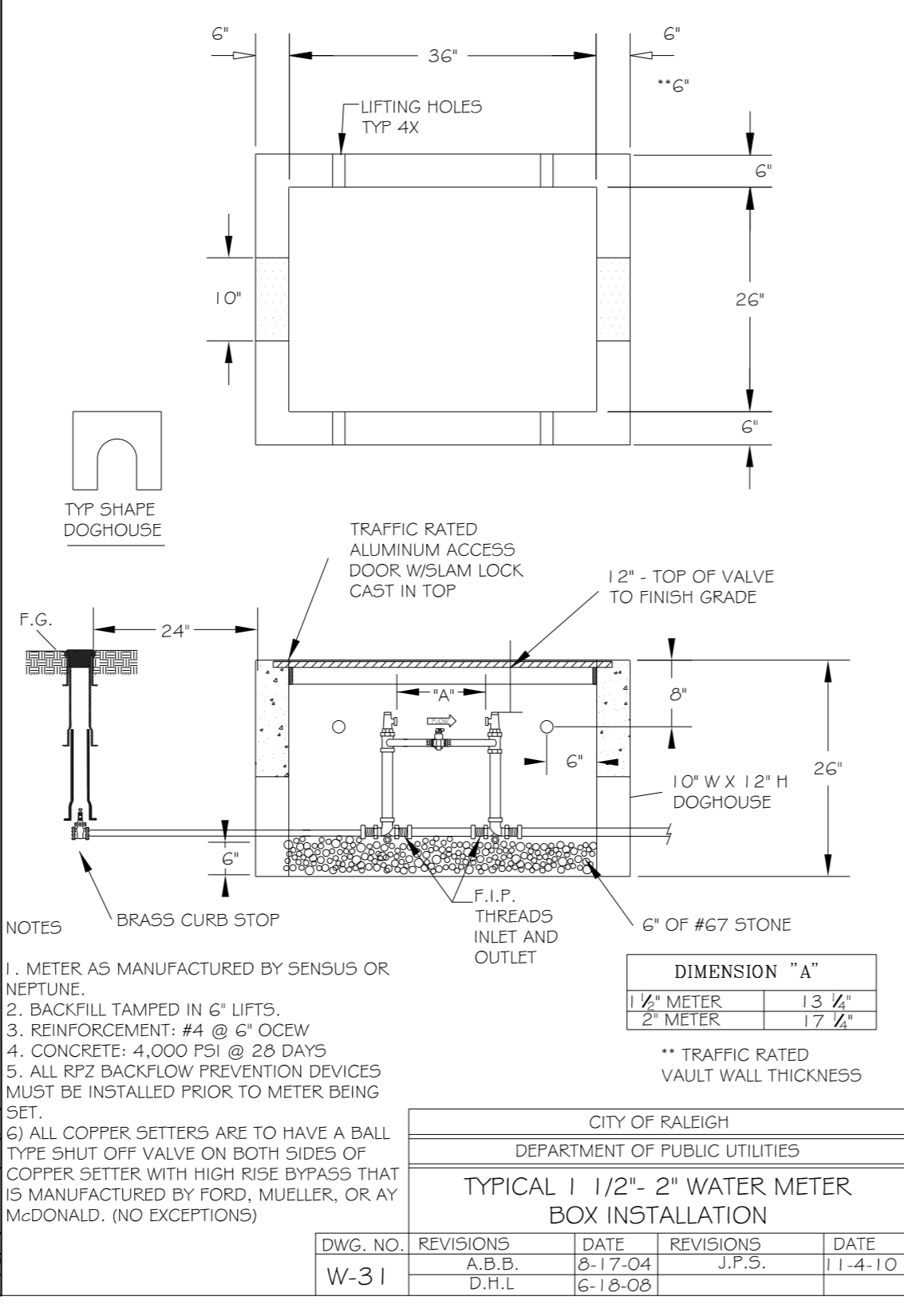
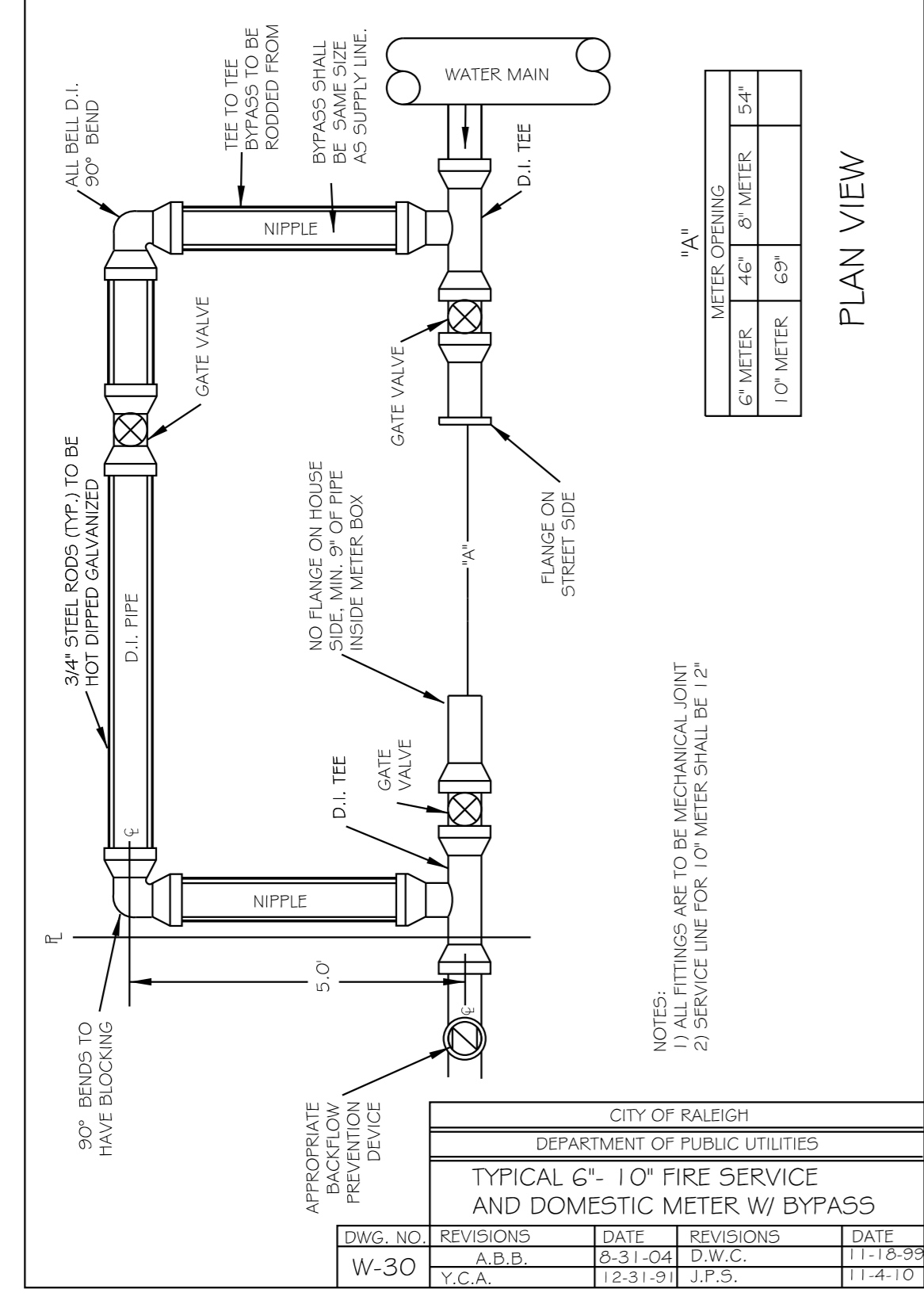
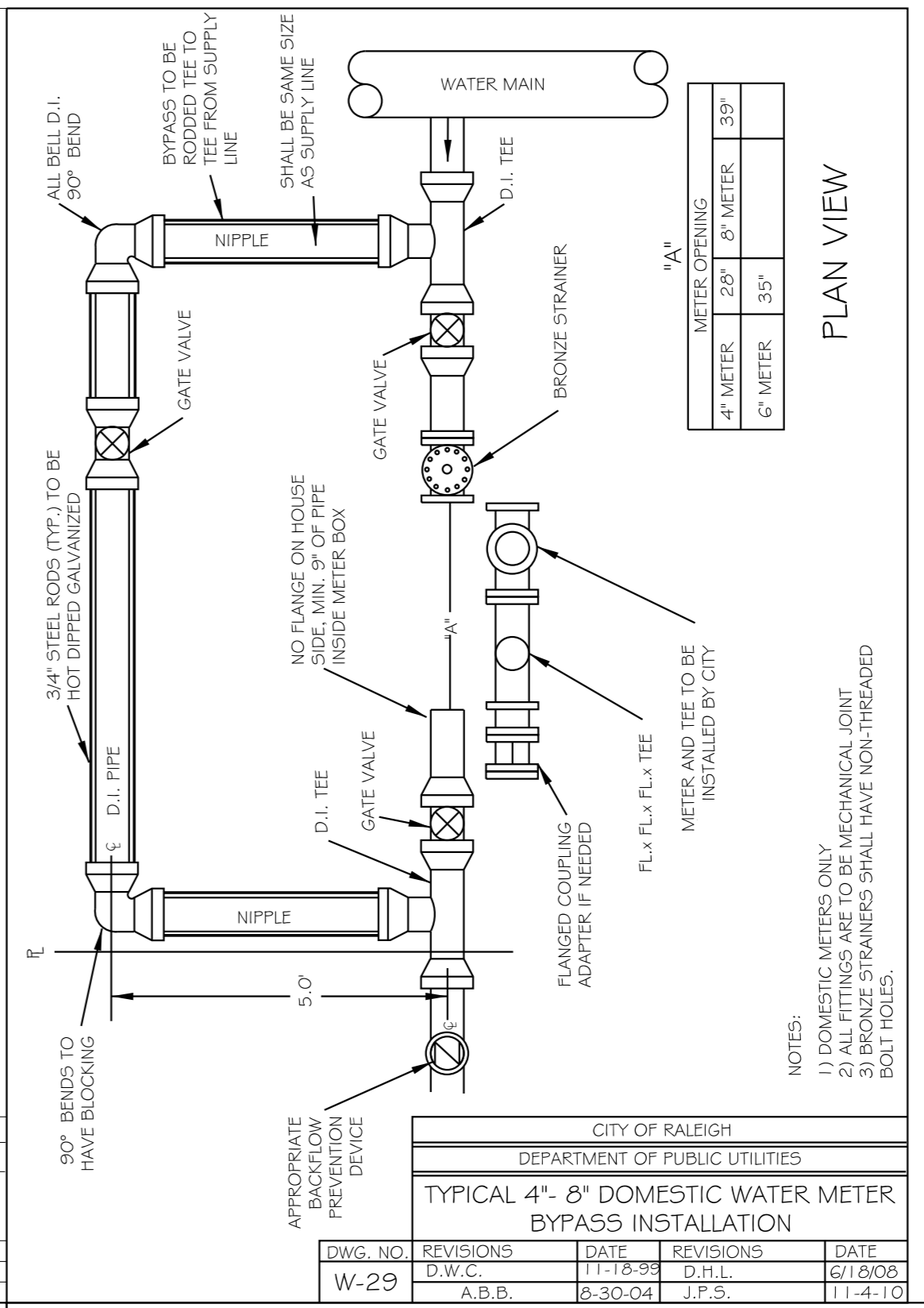
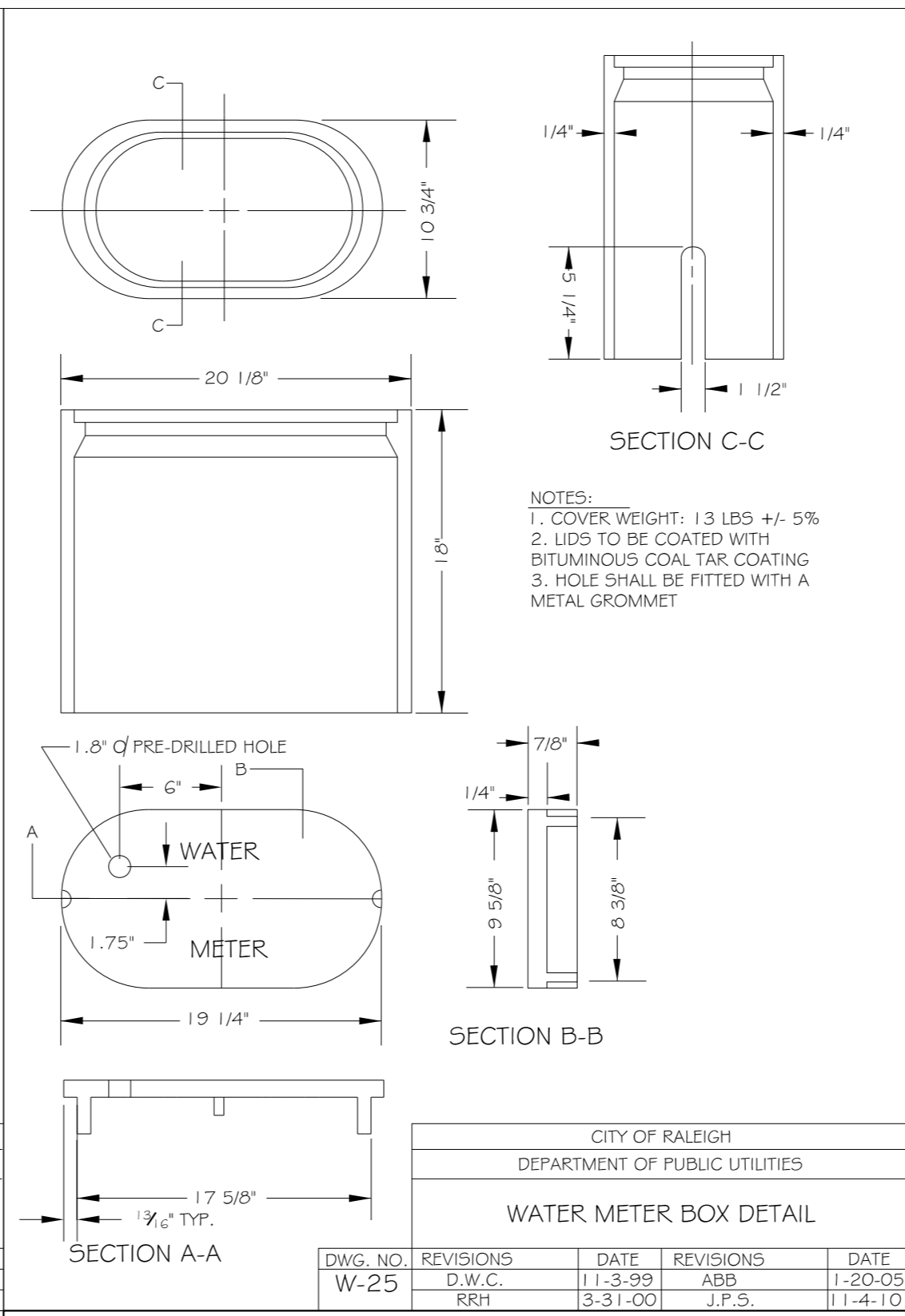
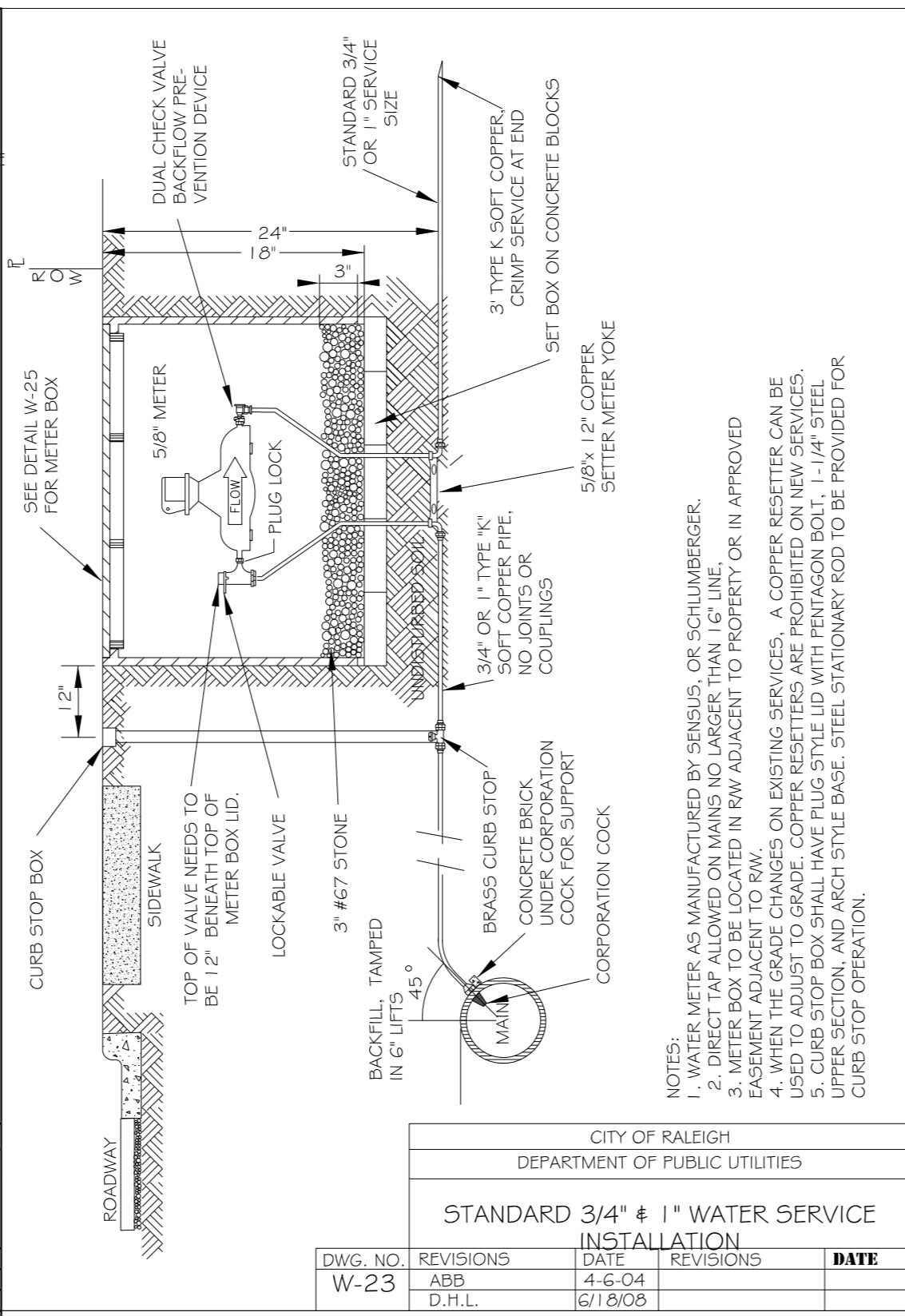
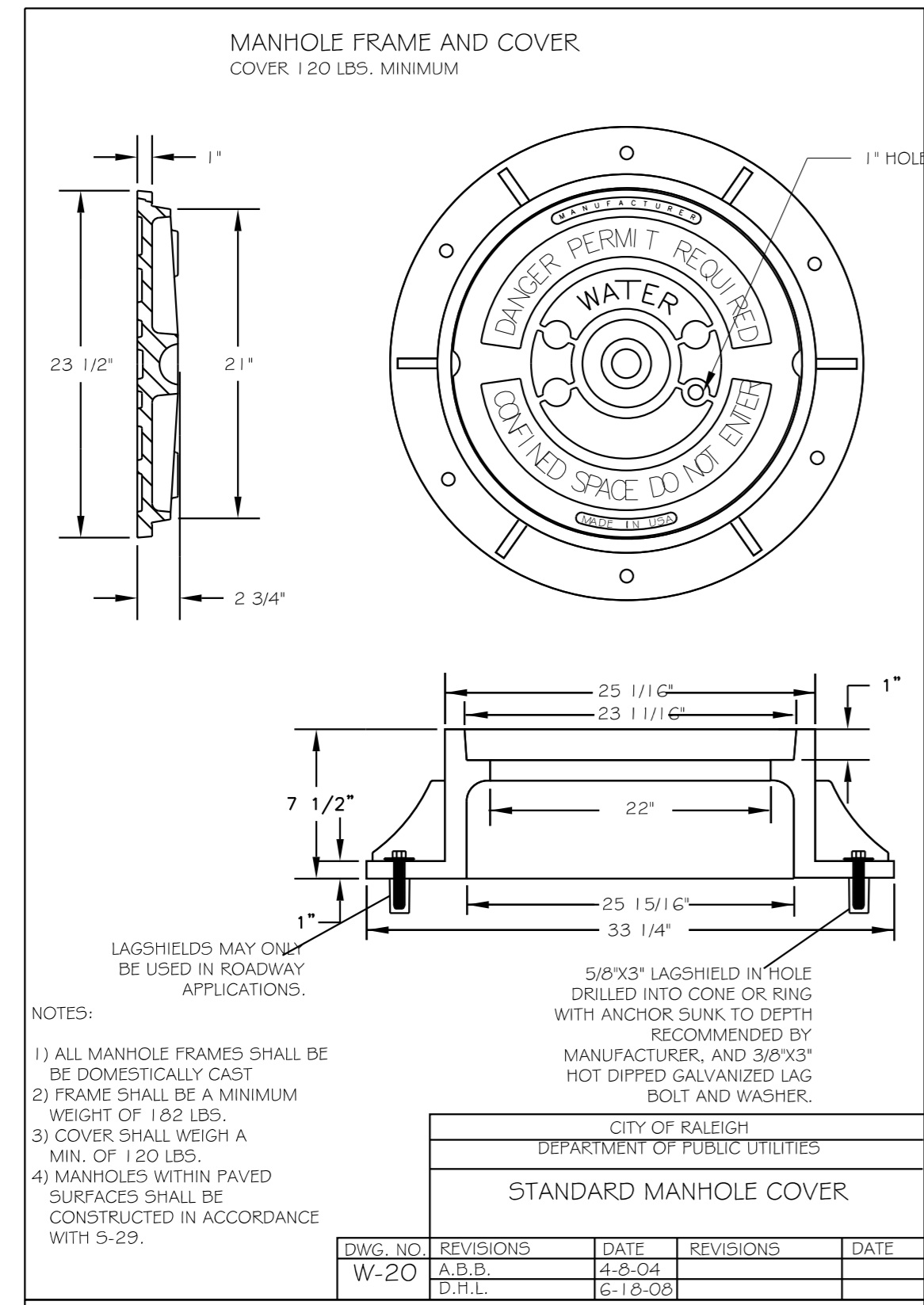

Water and Sewer Permits (if applicable)
The City of Raleigh consents to the connection and extension of the City's Public Sewer System as shown on this plan. The material and construction methods used for this project shall conform to the standards and specifications of the City's Public Utilities Handbook, City of Raleigh Public Utilities Department Permit # S-4499

The City of Raleigh consents to the connection and extension of the City's Public Water System as shown on this plan. The material and construction methods used for this project shall conform to the standards and specifications of the City's Public Utilities Handbook, City of Raleigh Public Utilities Department Permit # W-3682

The City of Raleigh consents to the connection and extension of the private sewer collection system as shown on this plan. The material and construction methods used for this project shall conform to the standards and specifications of the City's Public Utilities Handbook, City of Raleigh Public Utilities Department Permit # N/A

CITY OF RALEIGH - PLANS AUTHORIZED FOR CONSTRUCTION
Electronic Approval: This approval is being issued electronically. This approval is valid only upon the signature of a City of Raleigh Review Officer below. The City will retain a copy of this approved plan. Any work authorized by this approval must proceed in accordance with the plans kept on file with the City. This electronic approval may not be edited once issued. Any modification to this approval once issued will invalidate this approval.

City of Raleigh Development Approval _____
City of Raleigh Review Officer _____

REVISIONS