

3 Phase Fully Actuated (Raleigh Signal System)

DEFAULT PHASING DIAGRAM

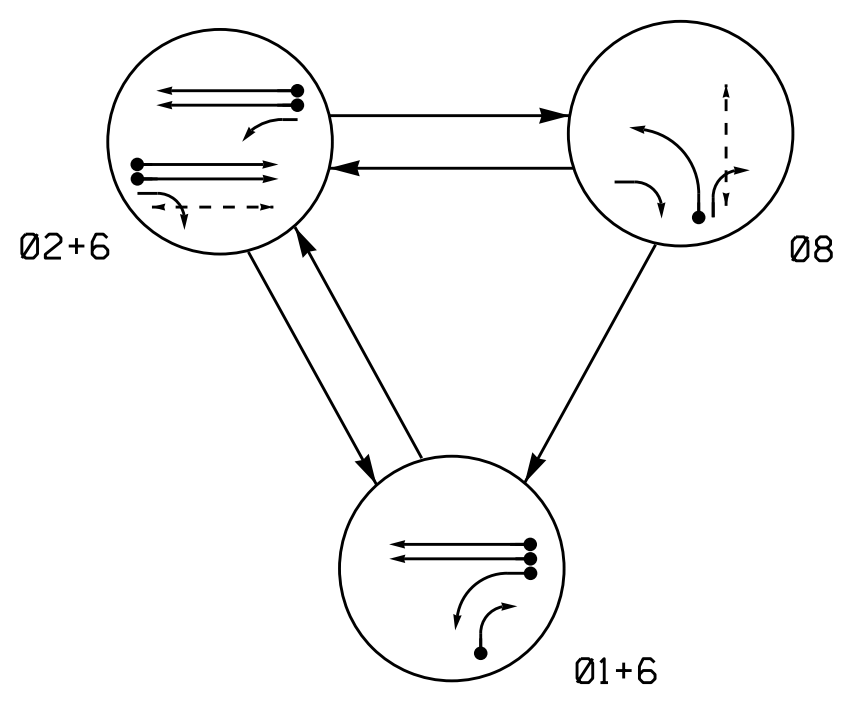

DEFAULT PHASING TABLE OF OPERATION

SIGNAL FACE	PHASE				
	01+6	02+6	08	DRK	Y
11	←	←	←	←	←
21, 22	R	G	R	Y	Y
23	R	←	←	←	←
61, 62	G	G	R	Y	Y
81, 83	R	R	←	R	←
82	←	R	←	R	←
P21, P22	DW	W	DW	DRK	DRK
P81, P82	DW	DW	W	DRK	DRK

ALTERNATE PHASING DIAGRAM

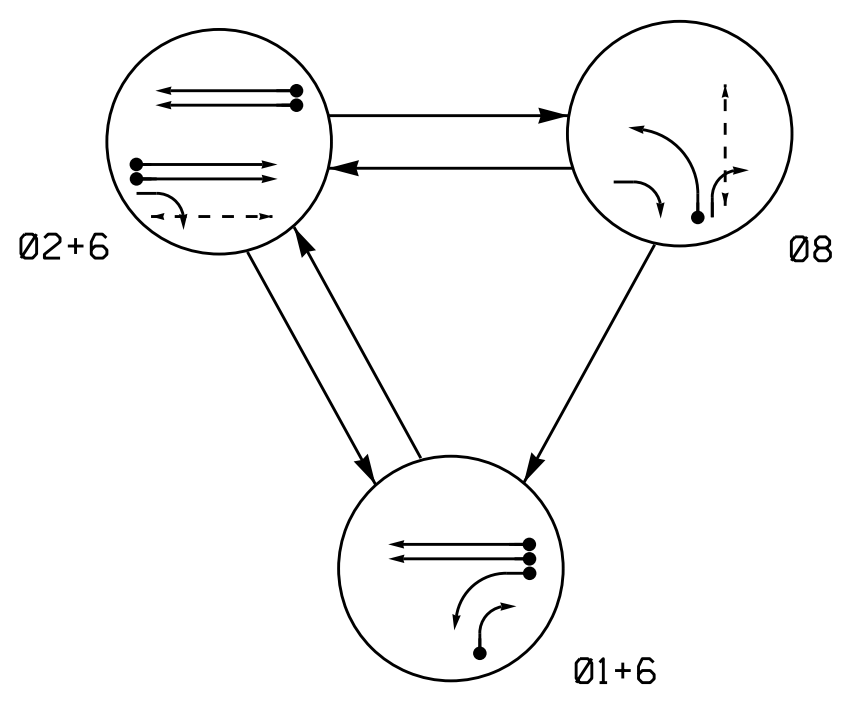

ALTERNATE PHASING TABLE OF OPERATION

SIGNAL FACE	PHASE				
	01+6	02+6	08	DRK	Y
11	←	←	←	←	←
21, 22	R	G	R	Y	Y
23	R	←	←	←	←
61, 62	G	G	R	Y	Y
81, 83	R	R	←	R	←
82	←	R	←	R	←
P21, P22	DW	W	DW	DRK	DRK
P81, P82	DW	DW	W	DRK	DRK

SIGNAL FACE I.D.

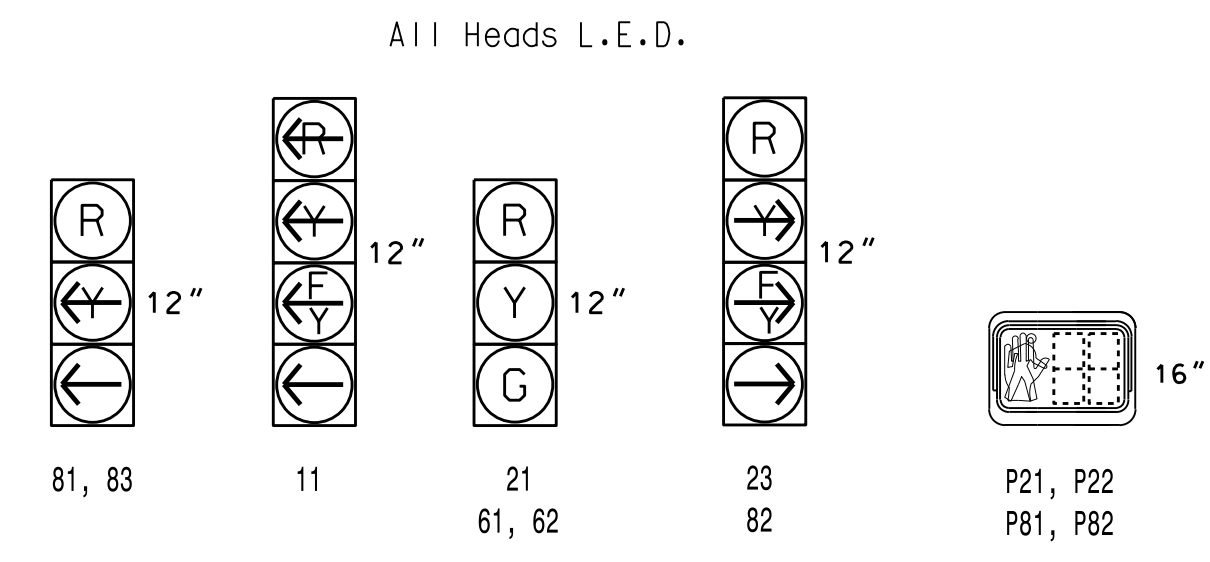

NOTES

- Refer to "Roadway Standard Drawings NCDOT" dated January 2024, "Standard Specifications for Roads and Structures" dated January 2024.
- Do not program signal for late night flashing operation unless otherwise directed by the Engineer.
- Phase 1 may be lagged.
- Reposition existing signal head(s) numbered 61 and 62.
- Set all detector units to presence mode.
- In the event of loop replacement, refer to the current ITS and Signal Design Manual and submit a Plan of Record to the Signal Design Section.
- Omit "WALK" and flashing "DON'T WALK" with no no pedestrian calls.
- Program pedestrian heads to countdown the flashing "Don't Walk" time only.
- Pavement markings are existing, unless otherwise shown.
- The Division (City) Traffic Engineer will determine the hours of use for each phasing plan.
- Maximum times shown in timing chart are for free-run operation only. Coordinated signal system timing values shall supersede these values.
- Program phase 4 as a dummy phase for Ring 1.

PHASING DIAGRAM DETECTION LEGEND

- ←● DETECTED MOVEMENT
- ← UNDETECTED MOVEMENT (OVERLAP)
- UNSIGNALIZED MOVEMENT
- ←--- PEDESTRIAN MOVEMENT

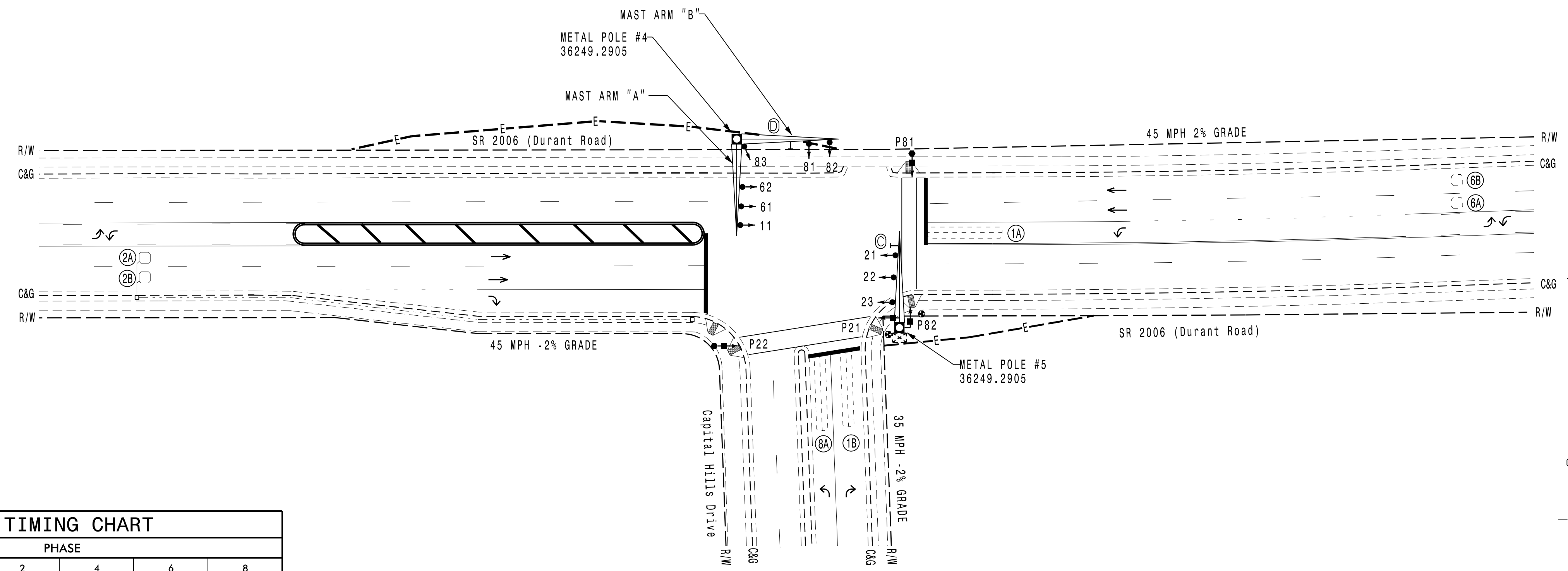

PROPOSED	EXISTING
	N/A
	N/A

SE-PAC 2070 TIMING CHART

FEATURE	PHASE				
	1	2	4	6	8
Min Green *	7	12	7	12	7
Passage Gap *	2.0	6.0	2.0	6.0	2.0
Maximum Green *	25	80	25	80	25
Yellow Change	3.0	4.7	3.0	4.7	3.0
Red Clear	3.2	1.9	2.9	1.9	2.9
Walk *	-	7	-	-	7
Pedestrian Clear	-	14	-	-	15
Added Initial *	-	1.5	-	1.5	-
Maximum Initial *	-	34	-	32	-
Time Before Reduction *	-	15	-	15	-
Time To Reduce *	-	45	-	45	-
Minimum Gap	-	3.0	-	2.7	-
Recall Mode	-	MIN RECALL	-	MIN RECALL	-
Vehicle Call Memory	NON-LOCK	LOCK	-	LOCK	NON-LOCK
Dual Entry	ON	-	ON	-	-
Simultaneous Gap	ON	ON	ON	ON	ON

\* These values may be field adjusted. Do not adjust Min Green and Extension times for phases 2 and 6 lower than what is shown. Min Green for all other phases should not be lower than 4 seconds.

LOOP & DETECTOR UNIT INSTALLATION CHART

LOOP NO.	SIZE (ft)	TURNS	DIST. FROM STOPBAR (ft)	NEW	EXISTING	ASSIGNED PHASE	DETECTOR PROGRAMMING																	
							TIMING		OPERATION MODE										STATUS					
							DELAY	EXTEND (STRETCH)	VEHICLE	PEDESTRIAN	T CALL	STOP A	STOP B	PROPPER	LEFT	RIGHT	THROUGH	AND	SWITCH	SYSTEM	LOOPS	NEW	EXISTING	
1A	6X40	2-4-2	0	-	X	1	5 SEC.	- SEC.	X	-	-	-	-	-	-	-	-	-	-	-	-	-	X	
1B	6X40	2-4-2	0	-	X	1	15 SEC.	- SEC.	X	-	-	-	-	-	-	-	-	-	-	-	-	-	-	X
2A	6X6	6	300	X	-	2	- SEC.	- SEC.	X	-	-	-	-	-	-	-	-	-	-	-	-	-	-	X
2B	6X6	6	300	X	-	2	- SEC.	- SEC.	X	-	-	-	-	-	-	-	-	-	-	-	-	-	-	X
6A	6X6	EXIST	280	-	X	6	- SEC.	- SEC.	X	-	-	-	-	-	-	-	-	-	-	-	-	-	-	X
6B	6X6	EXIST	280	-	X	6	- SEC.	- SEC.	X	-	-	-	-	-	-	-	-	-	-	-	-	-	-	X
8A	6X40	2-4-2	0	-	X	8	- SEC.	- SEC.	X	-	-	-	-	-	-	-	-	-	-	-	-	-	-	X

Signal Upgrade - Final Design

750 N. Greenfield Pkwy, Garner, NC 27529

SR 2006 (Durant Road) at Capital Hills Drive

Division 5 Wake County Raleigh

Prepared by: J.A. Lohr

Reviewed by: [Signature]

Date: May 2022

SEAL

05/26/2022

SIG. INVENTORY NO. 05-2387

20-0526-2023\_06-14  
 S:\IT\5304115\_Signal\Signal Design\Section\Central\_Regional\iv\_544-5720\_Durant\_Road\02387\_Sig.dwg, 20220526.dgn  
 10:00 AM