

PROJECT REFERENCE NO. P-5720	SHEET NO. 2D-1
RW SHEET NO.	
ROADWAY DESIGN ENGINEER	HYDRAULICS ENGINEER
DOCUMENT NOT CONSIDERED FINAL UNLESS ALL SIGNATURES COMPLETED	

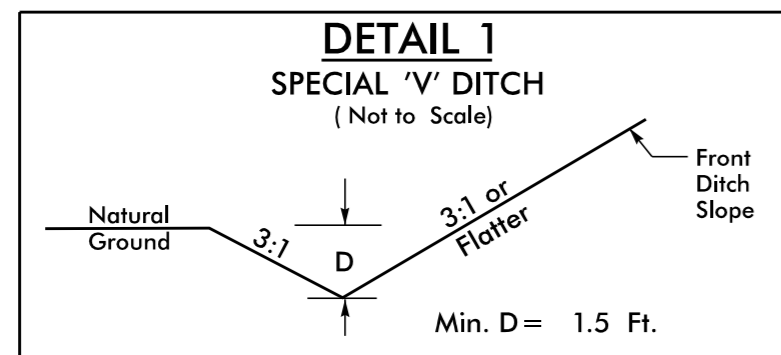

FROM STA. 12+00 TO STA. 13+00 -Y3- (LT)

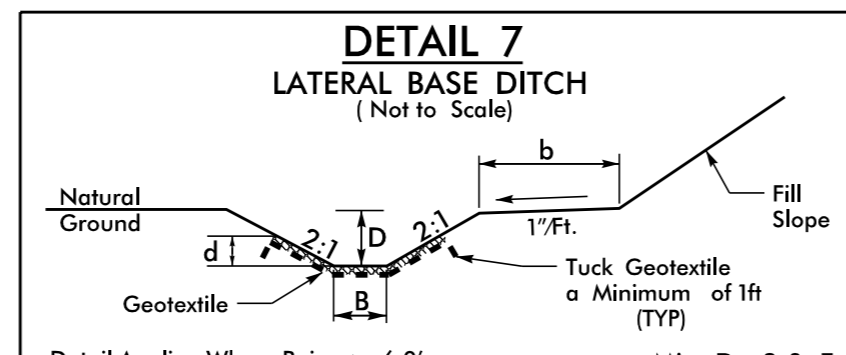

Detail Applies When B is < 6.0' for Class I and II Rip-Rap; And All Widths for Class B Rip-Rap
Type of Liner = Class B Rip-Rap, Keyed-In
FROM STA. 13+00 TO STA. 14+68 -Y3- (LT)

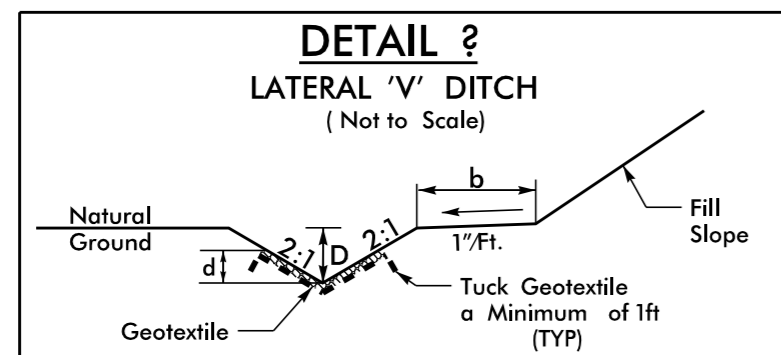

Type of Liner = Class B Rip-Rap, Keyed-In
FROM STA. 32+75 TO STA. 34+00 -L- (RT)

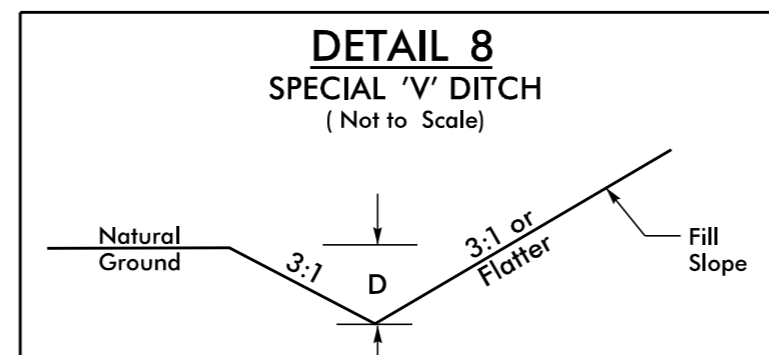

FROM STA. 18+50 TO STA. 19+65 -L- (RT)

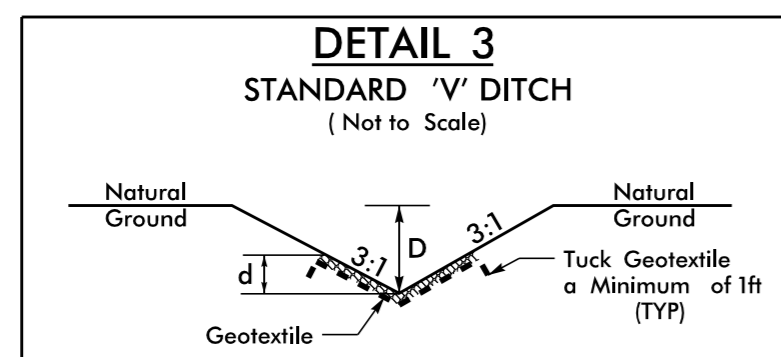

Type of Liner = Class B Rip-Rap, Keyed-In
FROM STA. 34+00 TO STA. 36+00 -L- (RT)

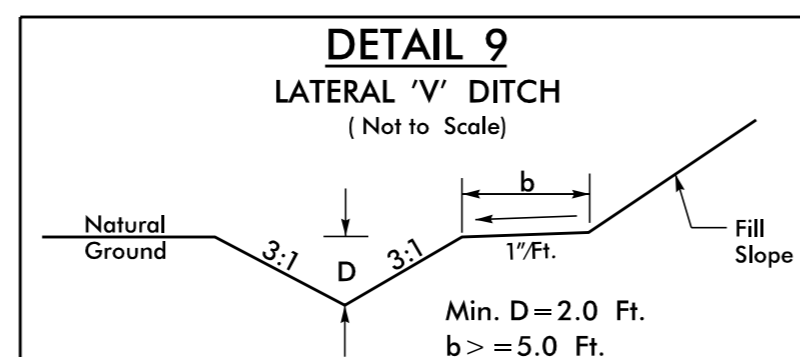

FROM STA. 19+65 TO STA. 23+45 -L- (RT)
FROM STA. 23+75 TO STA. 27+00 -L- (RT)

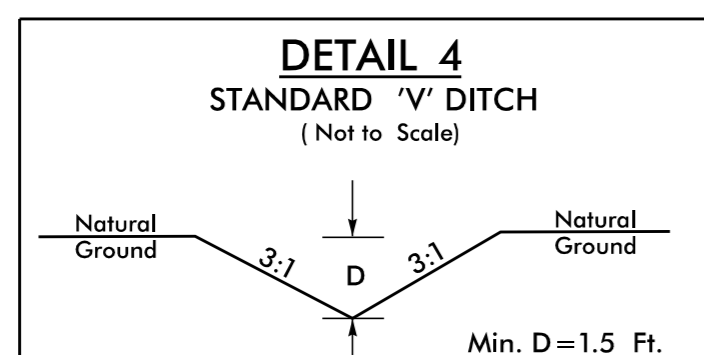

FROM STA. 36+00 TO STA. 37+40 -L- (RT)
FROM STA. 37+00 -L- (RT)
FROM STA. 38+30 TO STA. 40+22 -L- (RT)

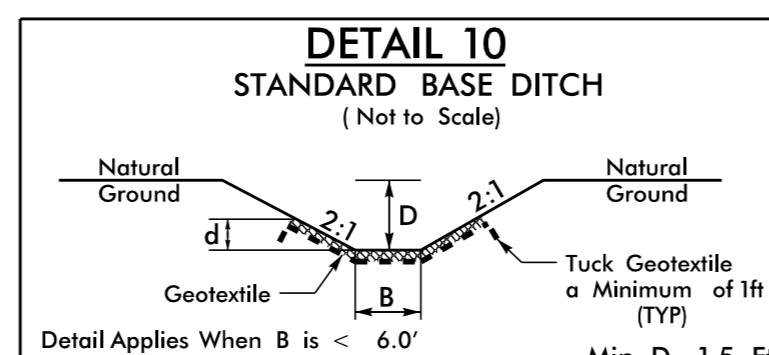

Detail Applies When B is < 6.0' for Class I and II Rip-Rap; And All Widths for Class B Rip-Rap
Type of Liner = Class I Rip-Rap, Keyed-In
FROM STA. 13+14 TO STA. 13+43 -Y2REV- (LT)

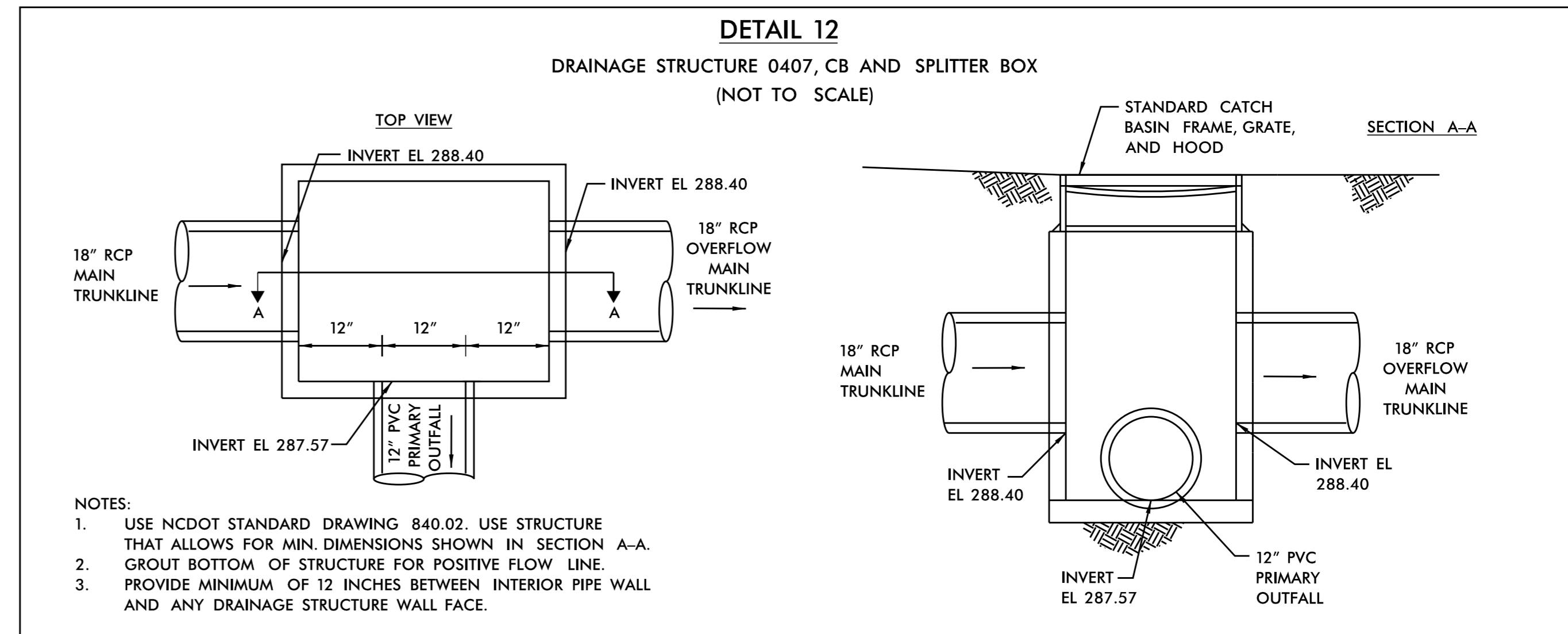

STA. 19+60 -L- (RT)

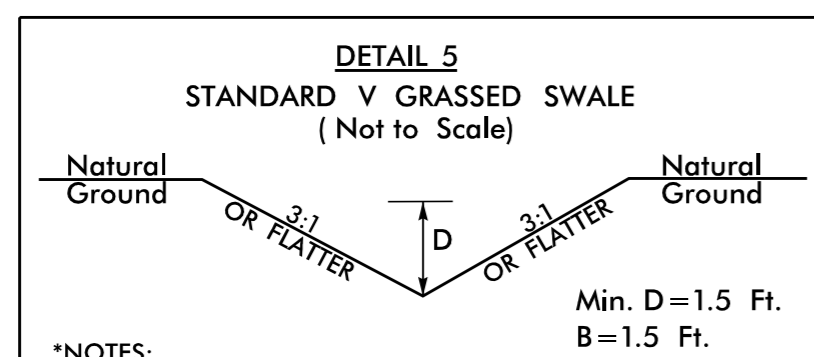

FROM STA. 29+50 TO STA. 31+50 -L- (RT)

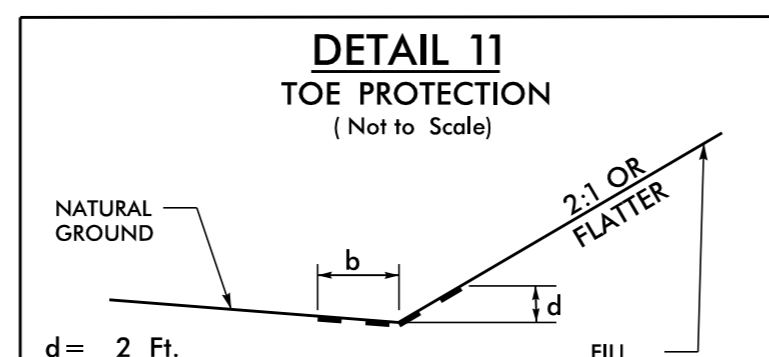

FROM STA. 42+50 TO STA. 44+00 -L- (LT)

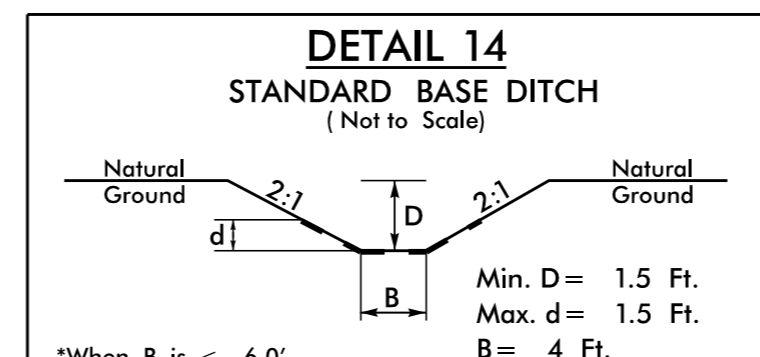

FROM STA. 12+80 -Y2REV- (RT)

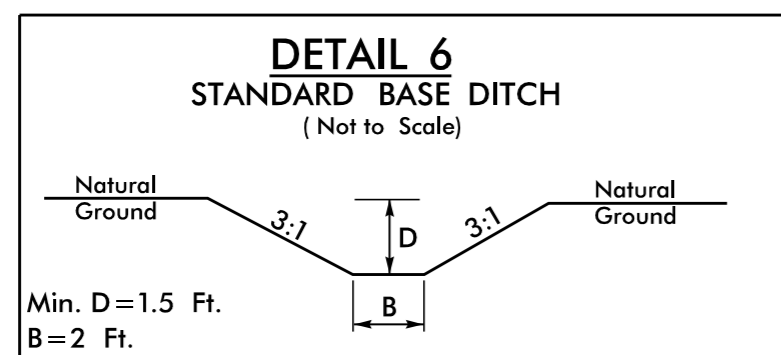

FROM STA. 32+35 -L- (RT)

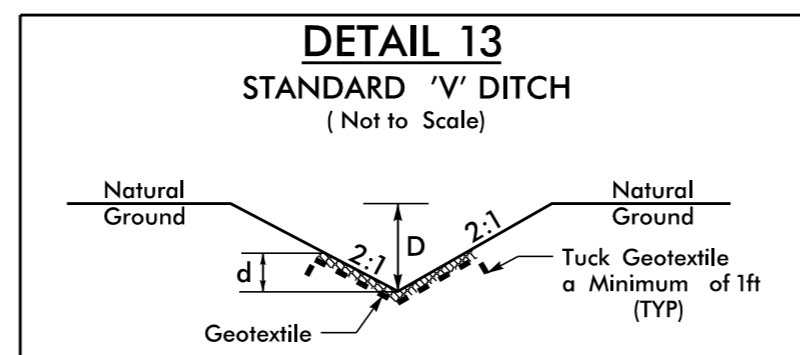

Type of Liner = Class B Rip-Rap, Keyed-In
FROM STA. 27+00 TO STA. 27+40 -L- (RT)