

NOTES:
 DETECTABLE WARNING SURFACE SHALL COVER 2'-0" LENGTH AND FULL WIDTH OF THE RAMP FLOOR AS SHOWN ON THE DETAILS.
 DETECTABLE WARNING SURFACE SHALL CONTRAST VISIBLY WITH ADJOINING SURFACE, EITHER LIGHT-ON-DARK, OR DARK-ON-LIGHT SEQUENCE COVERING THE ENTIRE RAMP.

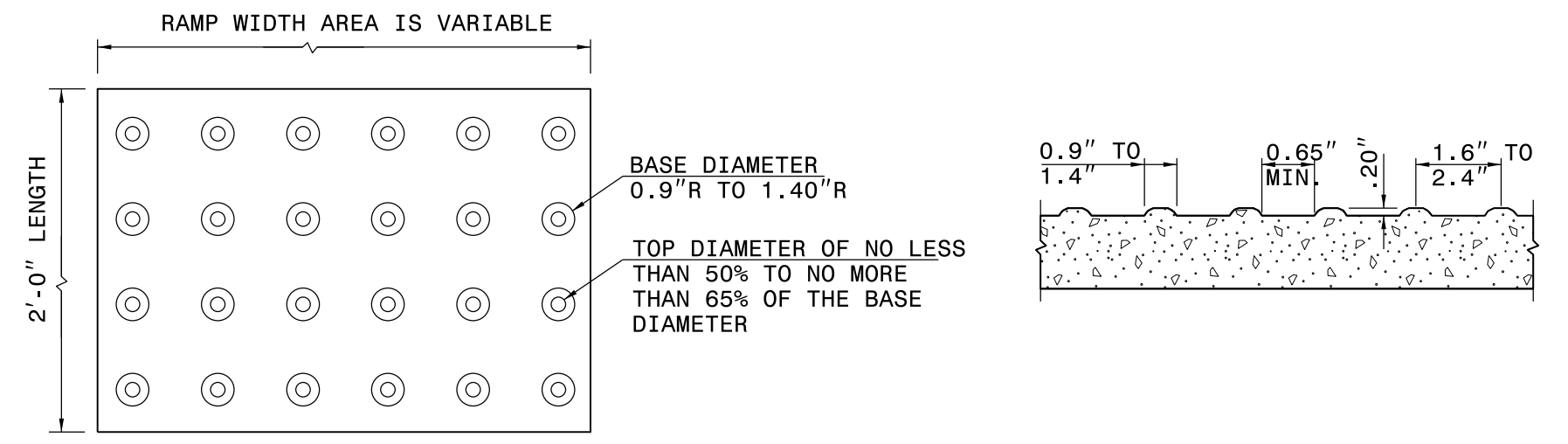

- 1 8.33% (12:1) MAX RAMP SLOPE
- 2 CROSS SLOPE: 2.00%
- 3 MAXIMUM CROSS SLOPE AND LONGITUDINAL SLOPE OF 2.00%

PAY LIMITS FOR 1 OR 2 CURB RAMPS
 (CALCULATE BASED ON NUMBER OF SETS OF DETECTABLE WARNING SURFACES)

STATE OF NORTH CAROLINA
 DEPT. OF TRANSPORTATION
 DIVISION OF HIGHWAYS
 RALEIGH, N.C.

ROADWAY DETAIL DRAWING FOR
CURB RAMP
 SHARED LANDING

SHEET 10 OF 13
848D06



DocuSigned by:
Nicole M. Hackler
 5884323D34164C5...

DOCUMENT NOT CONSIDERED FINAL
 UNLESS ALL SIGNATURES COMPLETED

CONTRACTS STANDARDS
 AND DEVELOPMENT UNIT
 Office 919-707-6950 FAX 919-250-4119

SEE TITLE BLOCK

ORIGINAL BY: S.CALHOUN DATE: 12-22-2023
 MODIFIED BY: DATE:
 CHECKED BY: DATE:
 FILE SPEC.: special_details\nmhackler\848D0610.dgn