

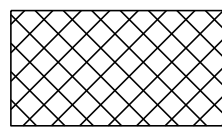
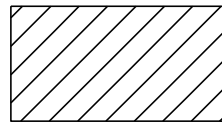

AS-BUILT REPAIR QUANTITY TABLE				
REPAIRS BENT 8	QUANTITIES			
	ESTIMATE		ACTUAL	
SHOTCRETE REPAIRS	AREA SF	VOLUME CF	AREA SF	VOLUME CF
CAP	0.0	0.0		
COLUMN	0.0	0.0		
CONCRETE REPAIRS	AREA SF	VOLUME CF	AREA SF	VOLUME CF
CAP	0.0	0.0		
COLUMN	0.0	0.0		
EPOXY RESIN INJECTION		LN. FT.	LN. FT.	
CAP		0.0		
COLUMN		0.0		
EPOXY COATING		SQ. FT.	SQ. FT.	
TOP OF BENT CAP		139.9		

VALUES IN CHART REPRESENT ESTIMATED REPAIR TOTALS AFTER REMOVAL OF UNSOUND CONCRETE, MIN. OF 1" BEHIND REBAR AND 2" MIN. CLEAR TO SAWCUT.

-  SHOTCRETE REPAIR
-  CONCRETE REPAIR
-  EPOXY RESIN INJECTION

PROJECT NO. 15BPR.130
CHATHAM COUNTY
 STATION: 180007

SHEET 1 OF 2

STATE OF NORTH CAROLINA
 DEPARTMENT OF TRANSPORTATION
 RALEIGH

BENT 8

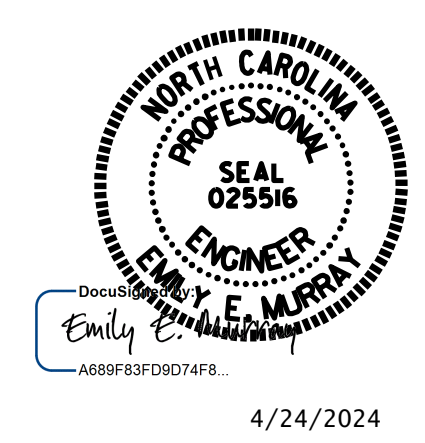

VOLKERT
 5430 Wade Park Blvd., Suite 410
 Raleigh, NC 27607
 Tel. 919-854-0344 Fax. 919-854-0355
 NC License No. F-0765

REVISIONS						SHEET NO.
NO.	BY:	DATE:	NO.	BY:	DATE:	S-34
1			3			TOTAL SHEETS
2			4			156

DOCUMENT NOT CONSIDERED FINAL UNLESS ALL SIGNATURES COMPLETED

DRAWN BY : S. C. NICHOLS DATE : 09/2022
 CHECKED BY : P. N. HOLDER DATE : 03/2024