

EXISTING JOINT

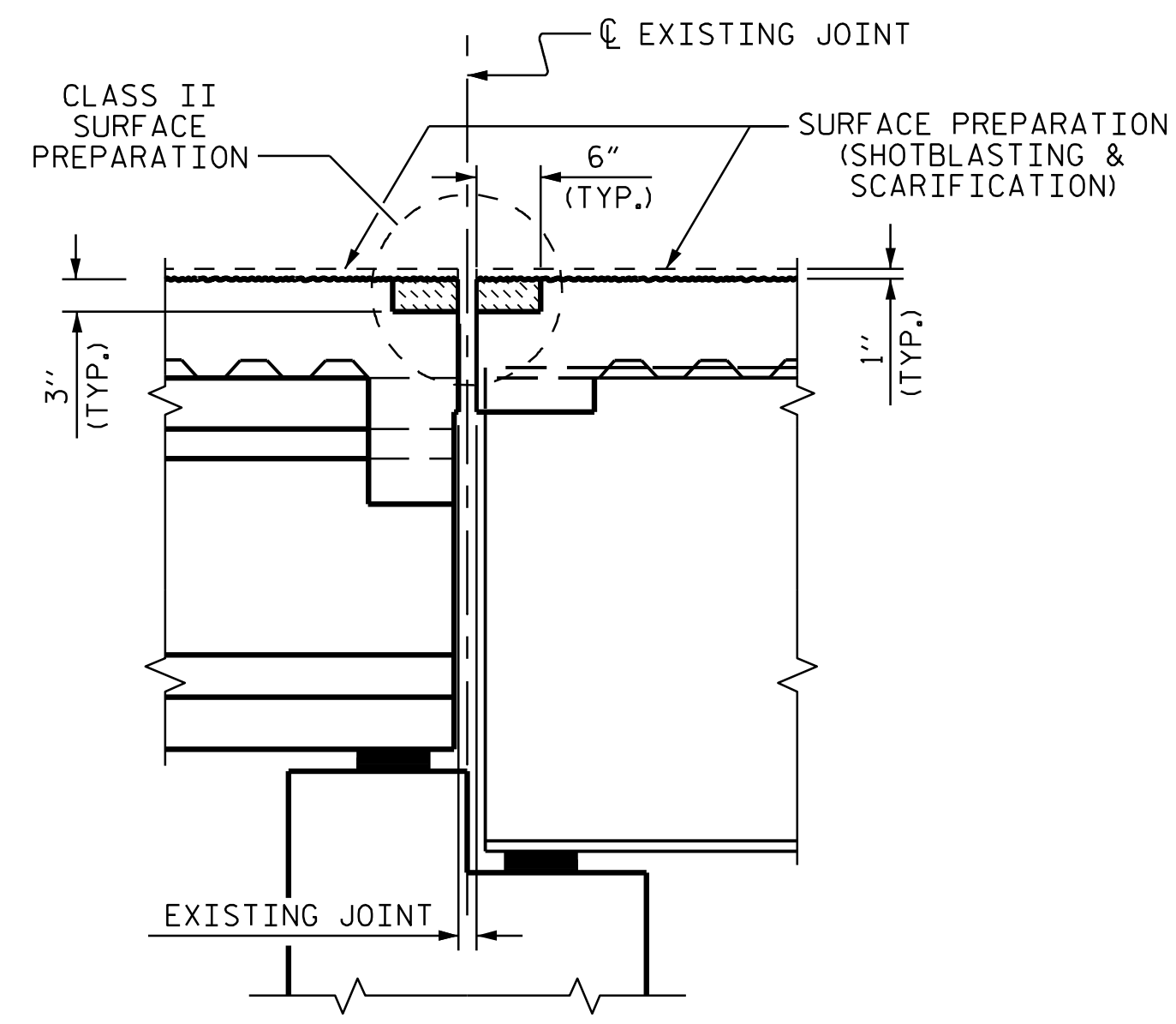

PROPOSED JOINT PREPARATION
(MINIMUM EXISTING JOINT DEMOLITION)

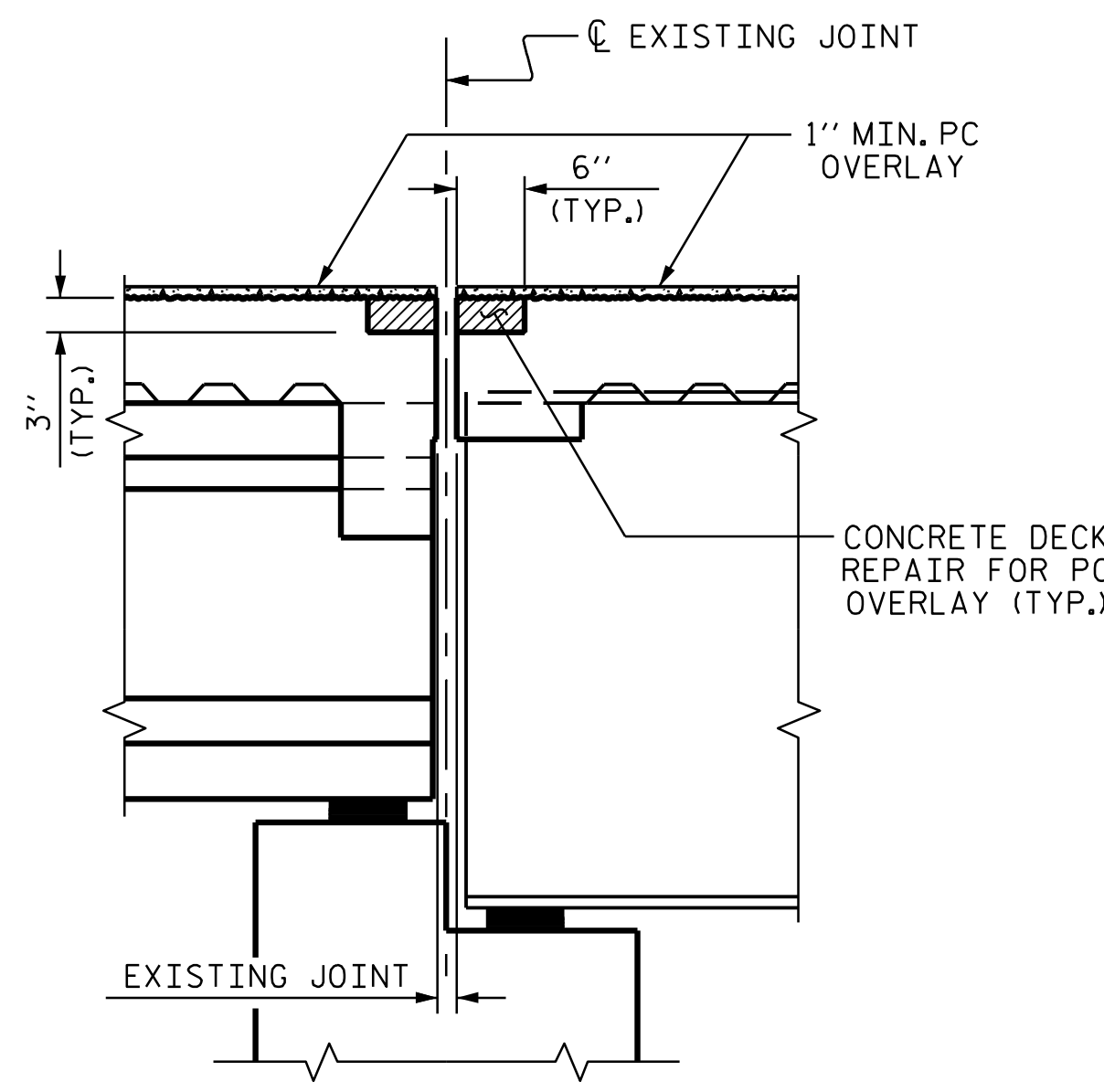

PROPOSED JOINT PRESAWED

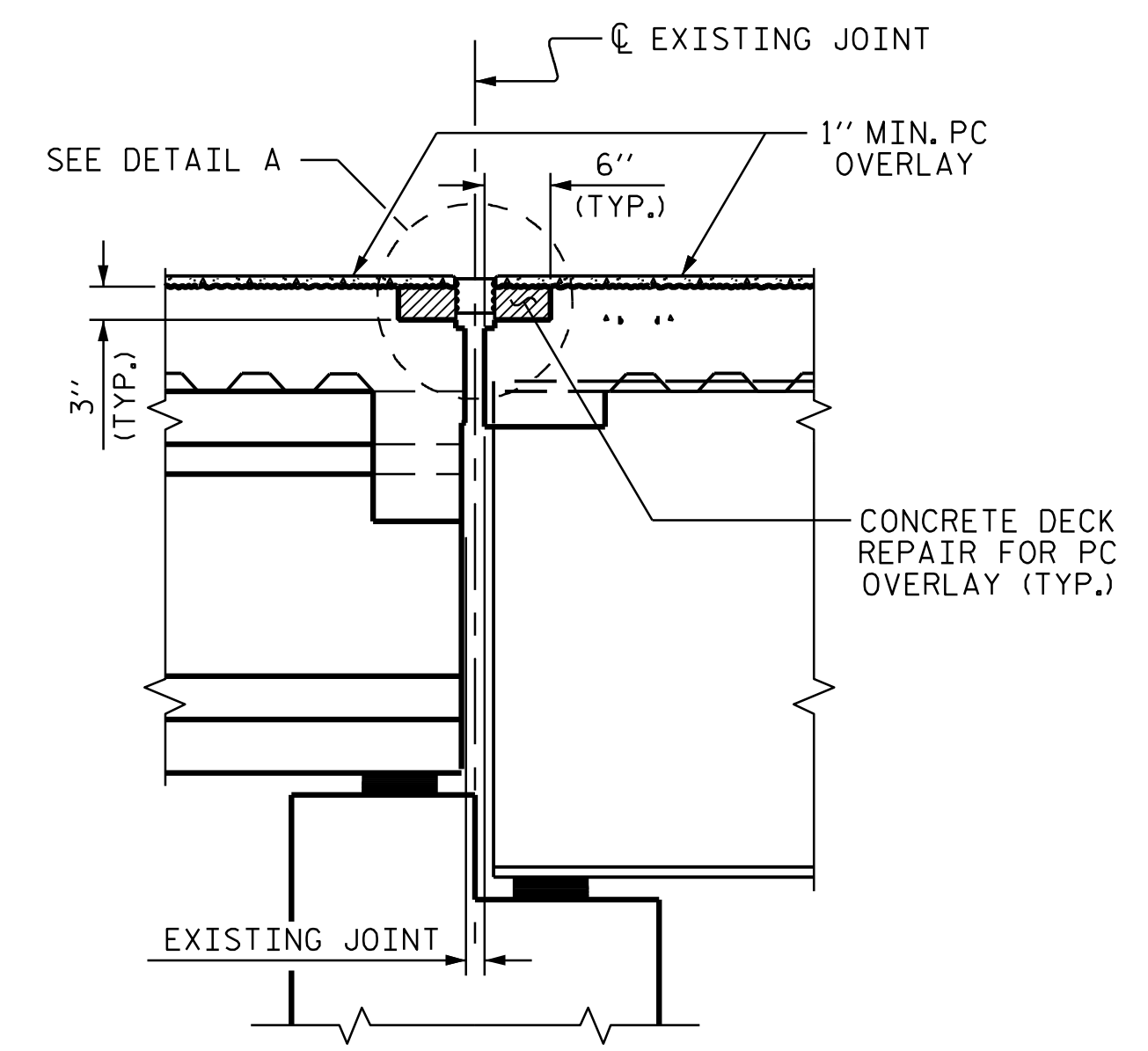

PROPOSED FOAM JOINT

JOINT INSTALLATION SEQUENCE AT BENT 10 (SECTION D-D)

NOTES

- THE CONTRACTOR SHALL FIELD VERIFY THE EXISTING JOINT OPENING PRIOR TO ORDER JOINT SEAL MATERIAL. IF THE ACTUAL JOINT OPENING VARIES FROM THE OPENING ALLOWED BY THE JOINT SEAL MATERIAL, NOTIFY THE ENGINEER. REVISION TO THE JOINT SEAL SIZE AND TYPE MIGHT BE NECESSARY.
- THE CONTRACTOR WILL NOT BE PERMITTED TO FORM THE JOINTS FOR THE JOINT SEALS IN LIEU OF SAWING THE JOINT.
- THE MANUFACTURER IS TO PROVIDE THE NOMINAL UNCOMPRESSED SEAL WIDTH OF THE FOAM JOINT SEAL BASED ON JOINT OPENINGS.
- FOR FOAM JOINT SEALS FOR PRESERVATION, SEE SPECIAL PROVISIONS.
- FOAM JOINT SEALS FOR PRESERVATION SHALL BE INSTALLED AS PER MANUFACTURER'S RECOMMENDATION.
- THE INSTALLED FOAM JOINT SEALS FOR PRESERVATION SHALL BE WATER TIGHT.
- FOR LOCATION OF SECTION D-D, SEE PLAN OF SPAN SHEETS.
- FINAL SURFACE OF THE JOINT DEMOLITION AREA PRIOR TO PLACEMENT OF CONCRETE REPAIR MATERIAL SHOULD BE REASONABLY FLAT AND LEVEL. ENGINEER SHALL DETERMINE THE ACCEPTABILITY OF THE SURFACE PRIOR TO PLACEMENT OF REPAIR CONCRETE.

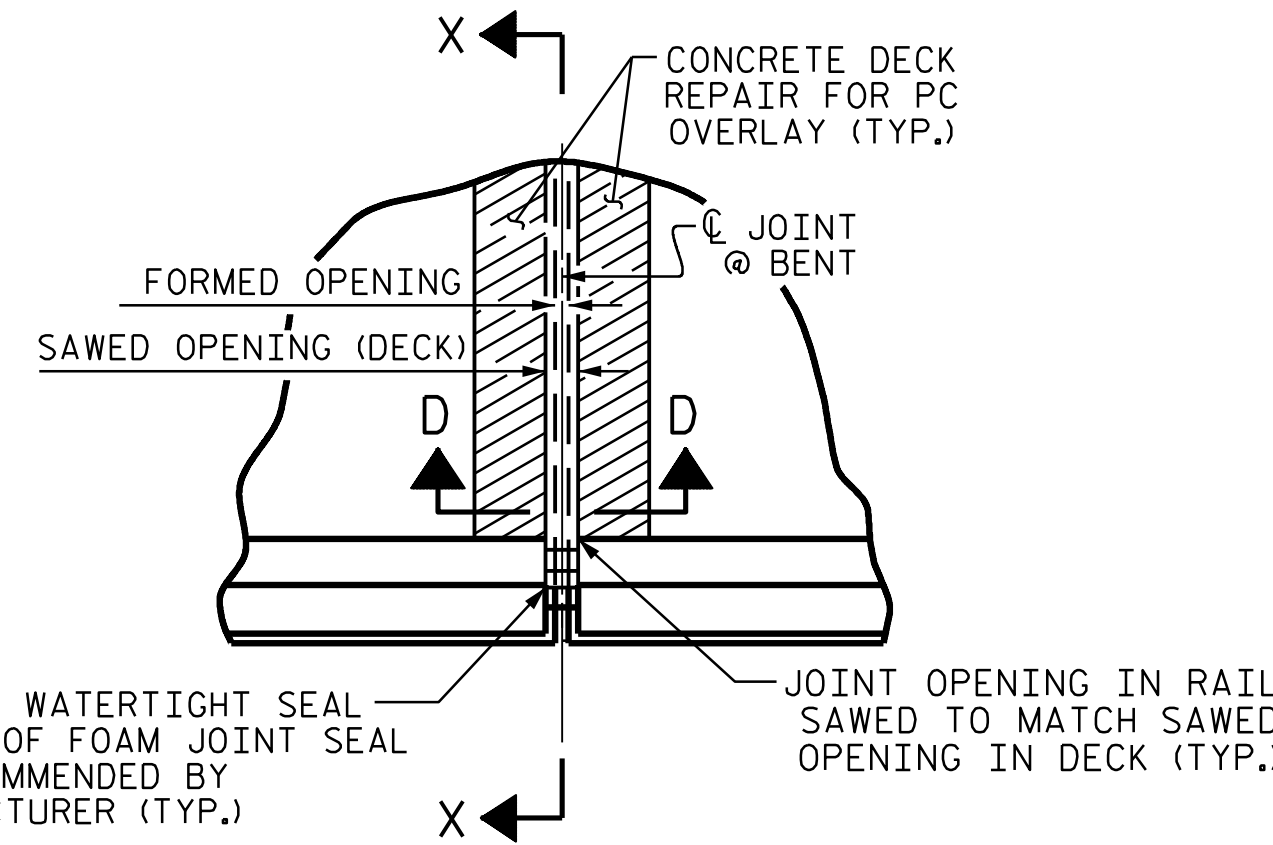

PLAN

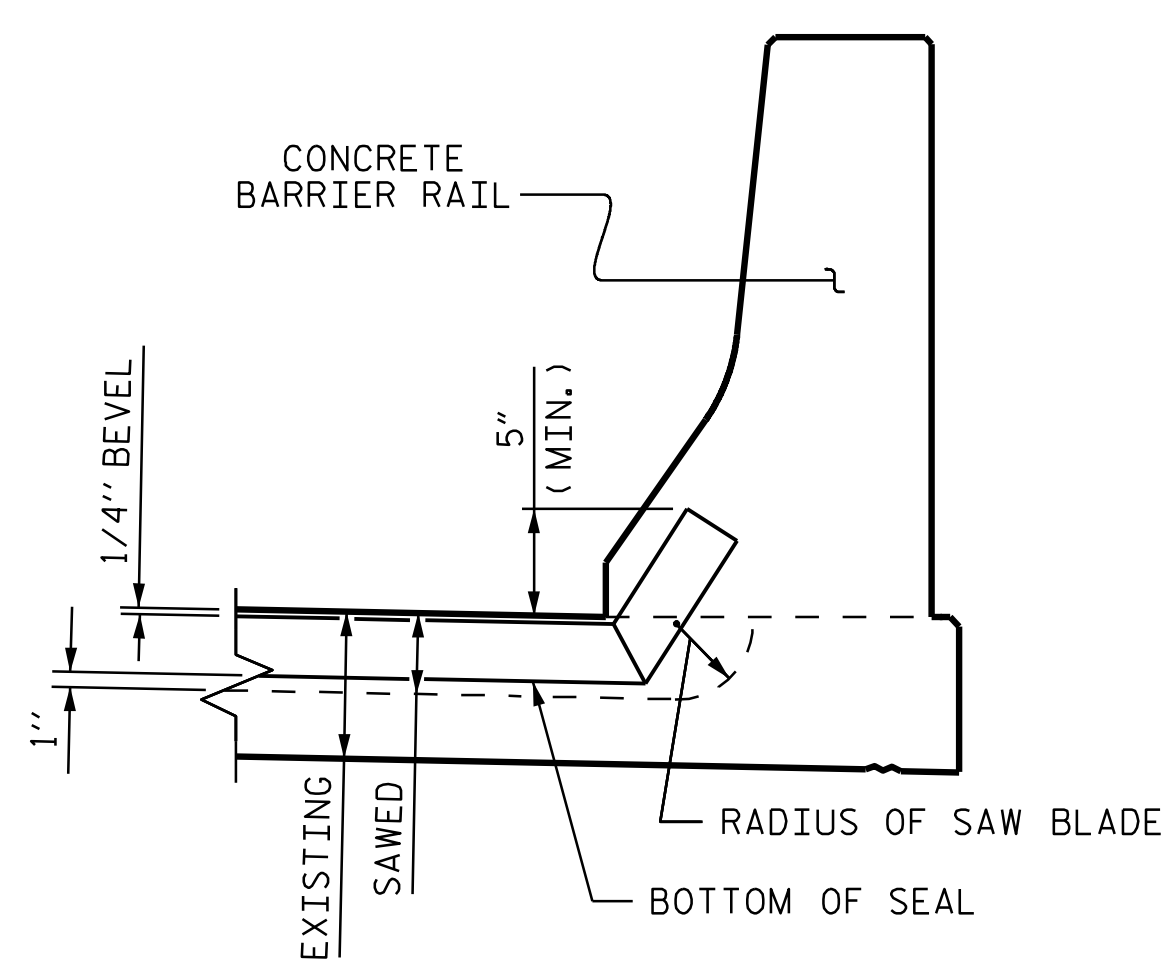

SECTION X-X

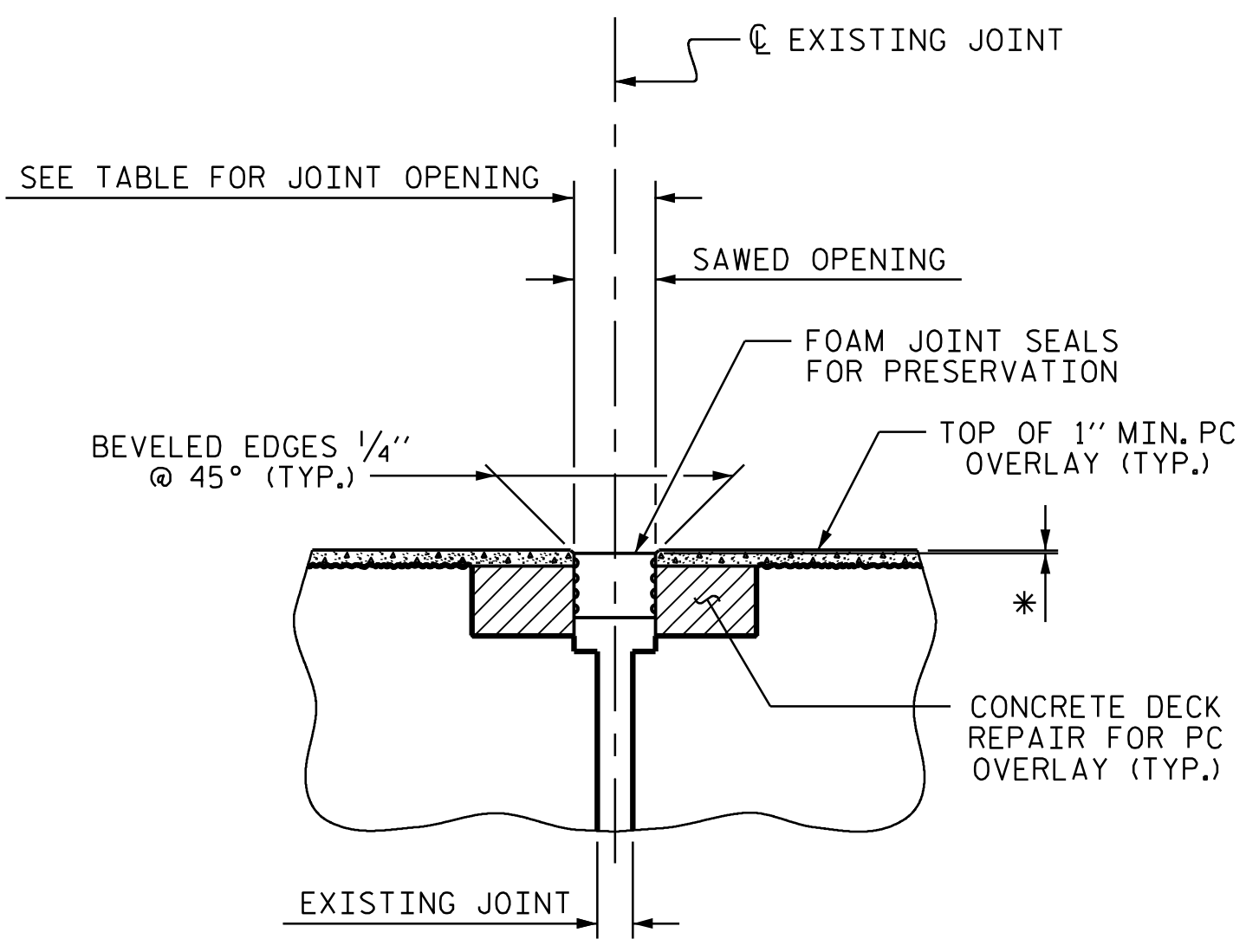

DETAIL A
(PROPOSED)

* FOAM JOINT SEALS FOR PRESERVATION SHALL BE RECESSED AS PER MANUFACTURER'S RECOMMENDATIONS.

JOINT SEAL DETAILS @ BENT 10

FOAM JOINT SEAL TO BE CUT, HEAT WELDED AND TURNED UP PARALLEL TO SLOPED FACE OF THE BARRIER RAIL.

PROJECT NO. 15BPR.130
CHATHAM COUNTY
BRIDGE NO: 180007

SHEET 4 OF 6

JOINT REPAIR QUANTITY	
LOCATION	FOAM JOINT SEALS FOR PRESERVATION ESTIMATED (LIN. FT.)
BENT 10	39.0

SAWED JOINT OPENING TABLE				
LOCATION	SKEW ANGLE	PERPENDICULAR JOINT OPENING AT 45°	PERPENDICULAR JOINT OPENING AT 60°	PERPENDICULAR JOINT OPENING AT 90°
BENT 10	90°00'00"	1 1/16"	1 9/16"	1 3/8"

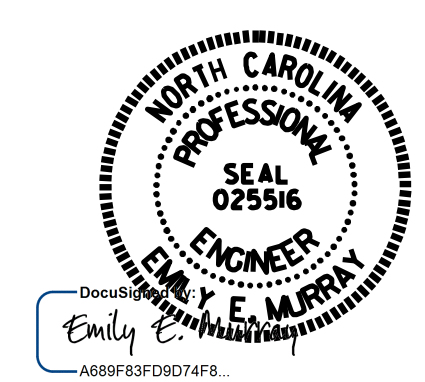

4/24/2024

STATE OF NORTH CAROLINA
DEPARTMENT OF TRANSPORTATION
RALEIGH

JOINT REPAIR DETAILS AT BENT 10

DRAWN BY: D. A. GLADDEN DATE: 5/23
CHECKED BY: E. E. MURRAY DATE: 3/24

VOLKERT
5430 Wade Park Blvd, Suite 410
Raleigh, NC 27607
Tel: 919-854-0344 Fax: 919-854-0355
NC License No. F-0765

DOCUMENT NOT CONSIDERED FINAL UNLESS ALL SIGNATURES COMPLETED

REVISIONS						SHEET NO.
NO.	BY:	DATE:	NO.	BY:	DATE:	S-16
1			3			TOTAL SHEETS
2			4			156