

K:\CHL_PRJ\01036359 - U-5108 (Northcross) DSM\Roadway\XSCU-5108_ry_xpl.dgn
 4/22/2024

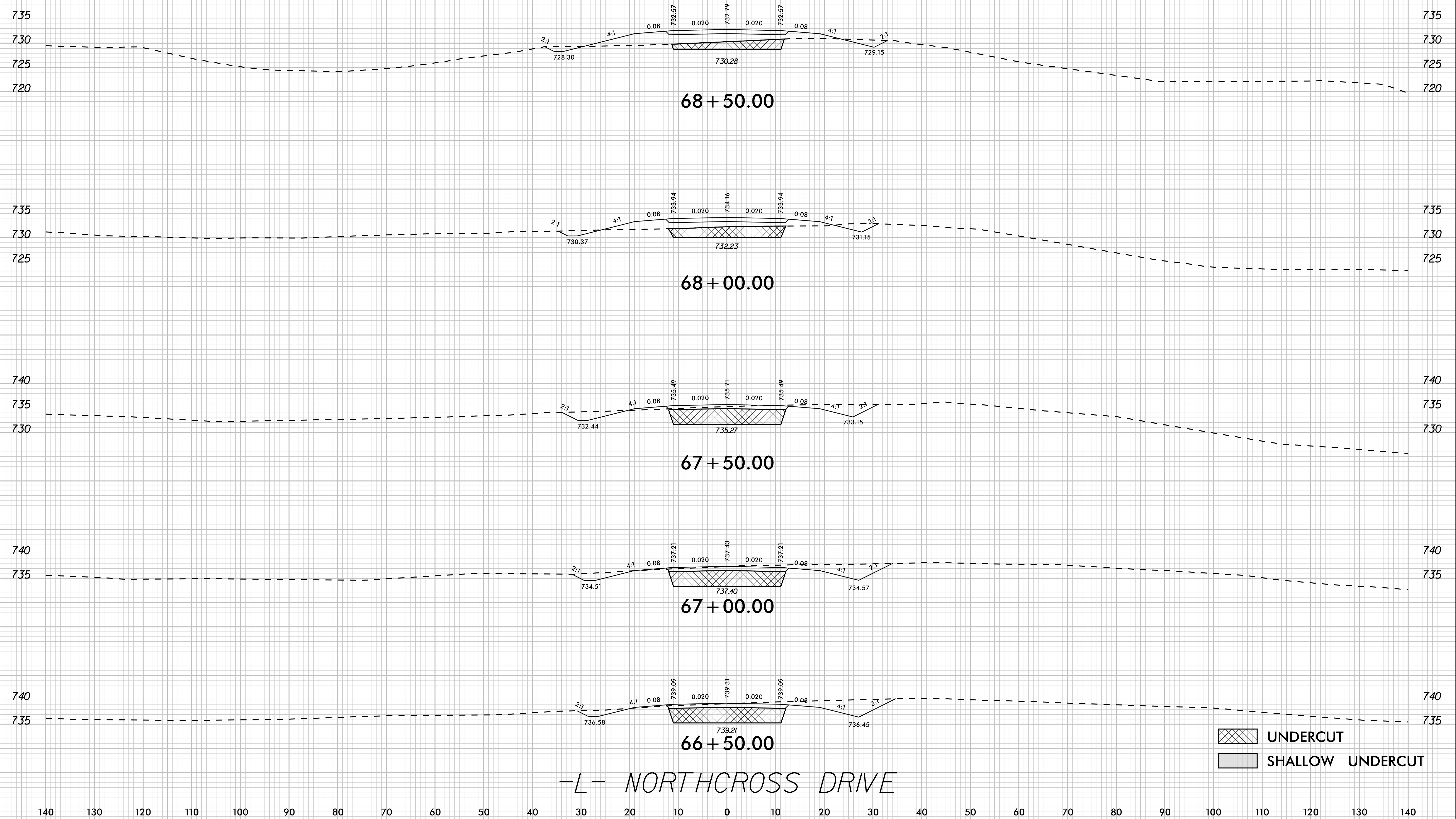

-L- NORTH CROSS DRIVE

UNDERCUT
 SHALLOW UNDERCUT

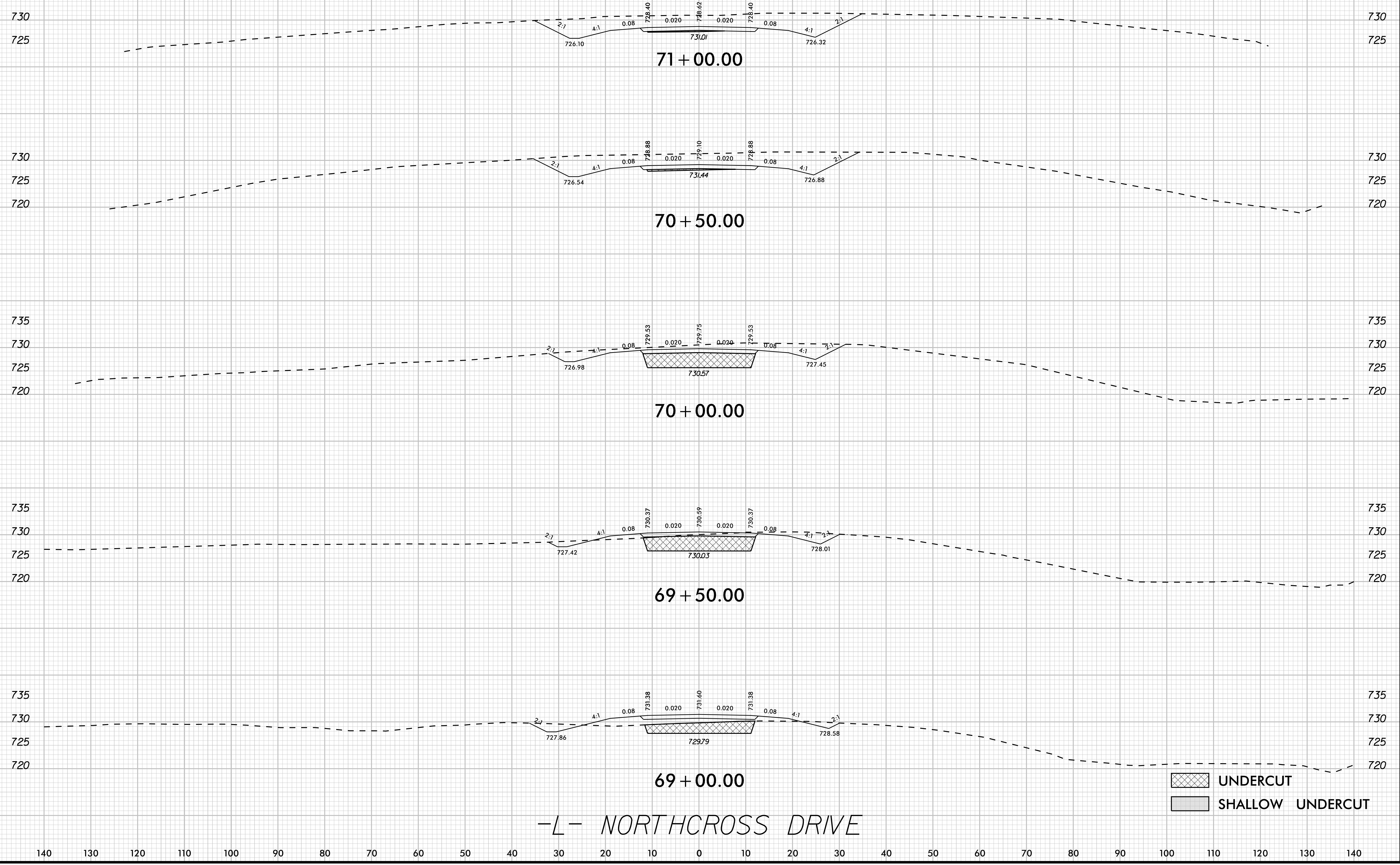

-L- NORTHCROSS DRIVE

UNDERCUT
 SHALLOW UNDERCUT

4/22/2024 K:\CHL_PROJ\01036359 - U-5108 (Northcross) DSN\Roadway\XSCU-5108_roy_xpl.dgn

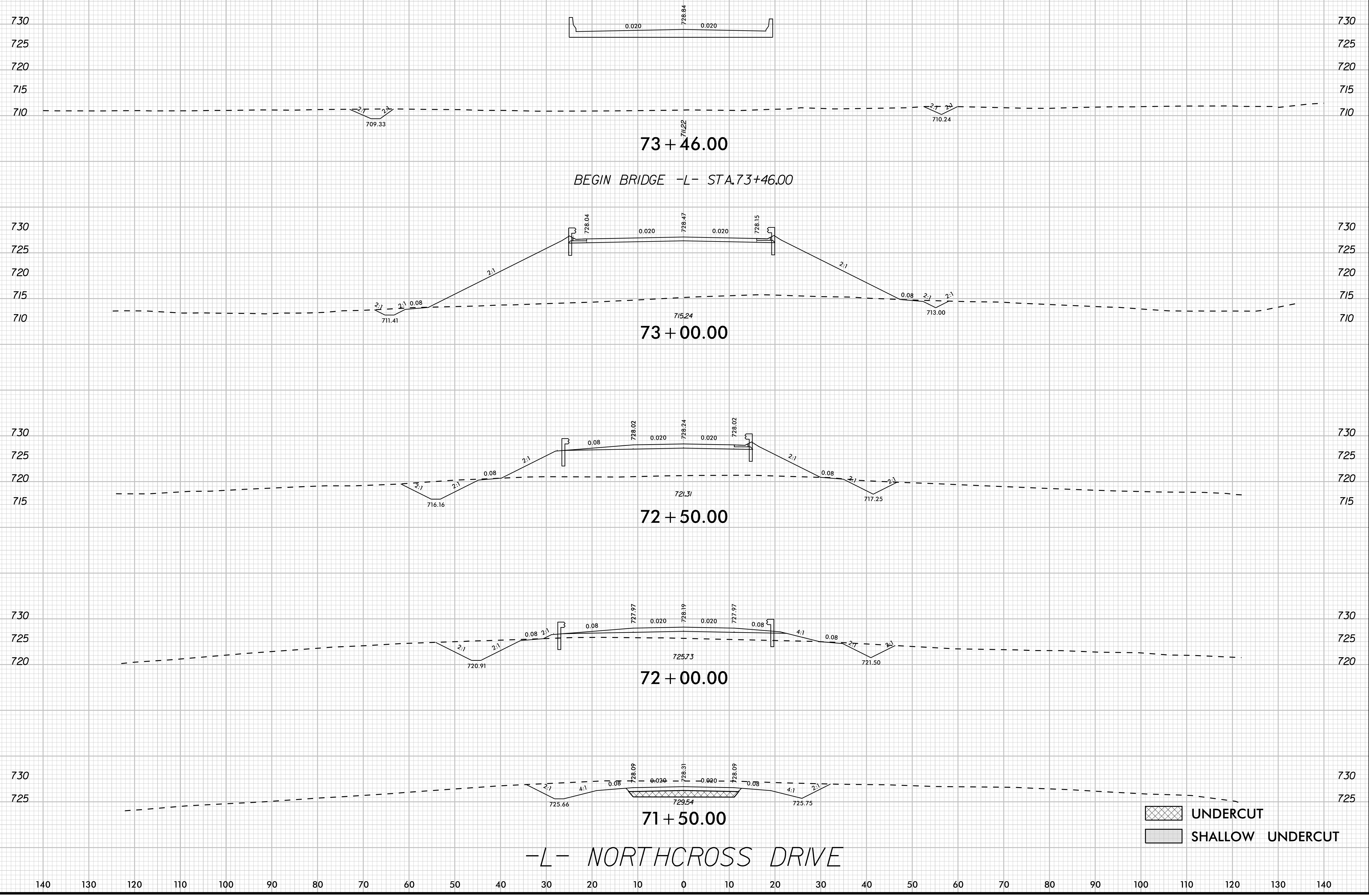

UNDERCUT
 SHALLOW UNDERCUT

-L- NORTH CROSS DRIVE

4/22/2024 K:\CHL_P\0101036359 - U-5108 (Northcross) DSN\Roadway\XSCU-5108_rdy_xpl.dgn

END BRIDGE -L- STA.74+56.00

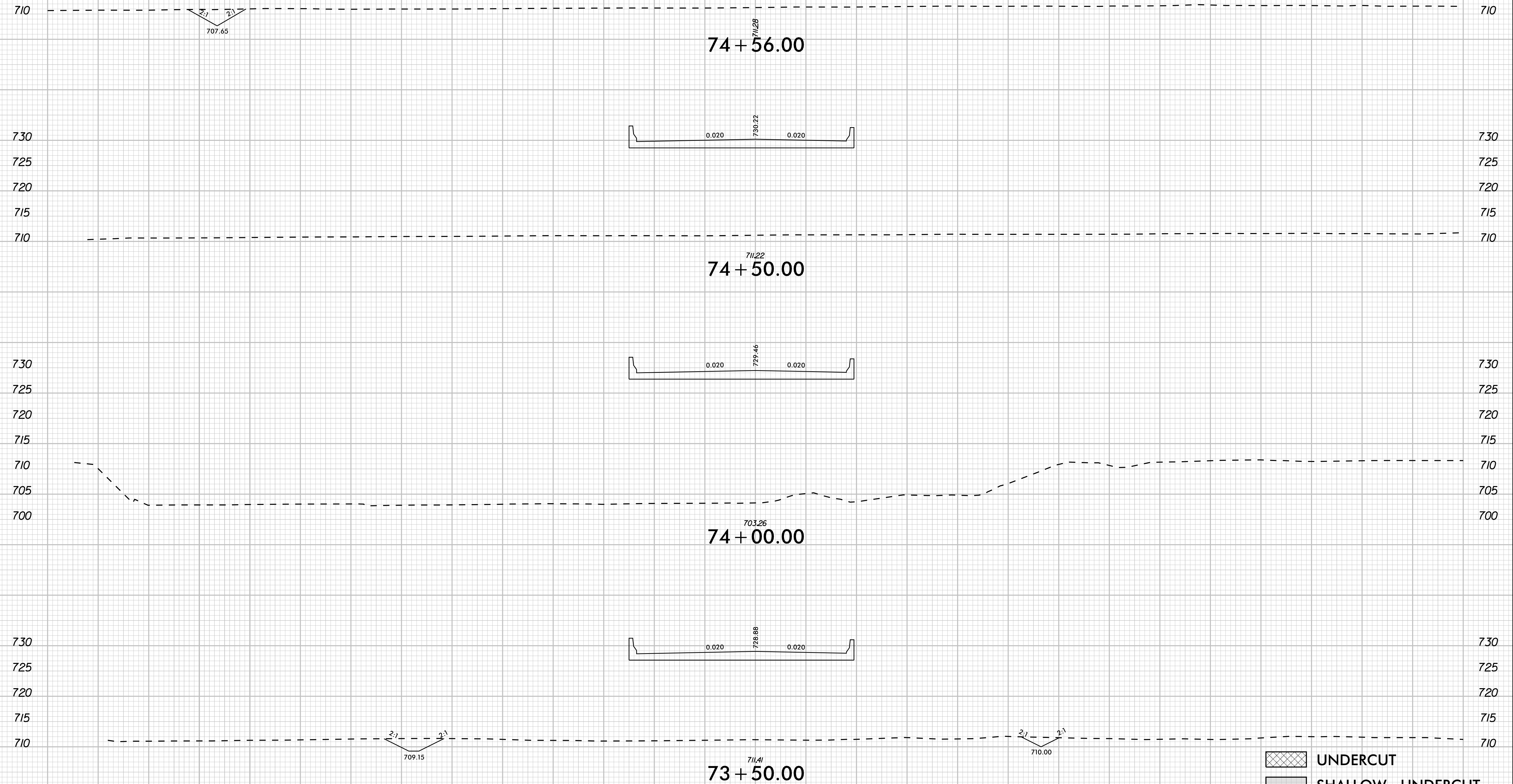

-L- NORTHCROSS DRIVE

K:\CHL_PROJ\01036359 - U-5108 (Northcross) DSN\Roadway\XSCU-5108_roy_xpl.dgn 4/22/2024

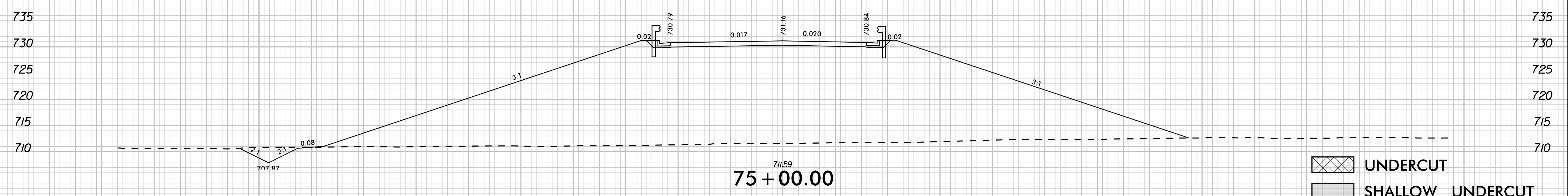
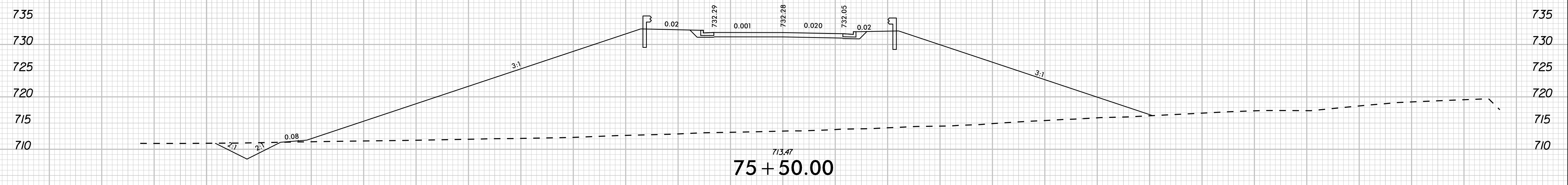
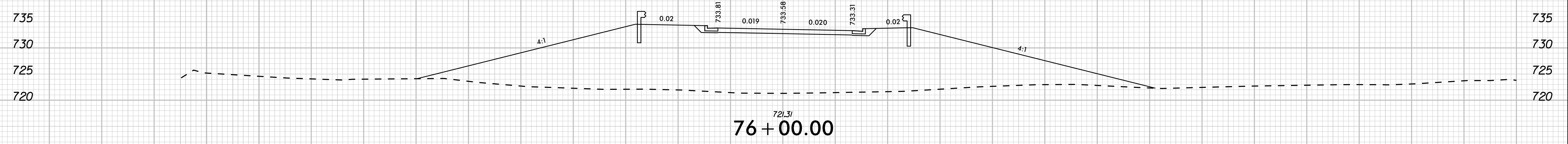
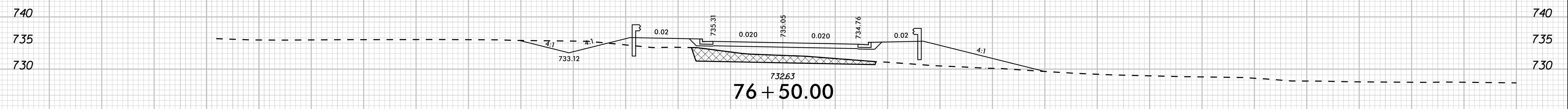
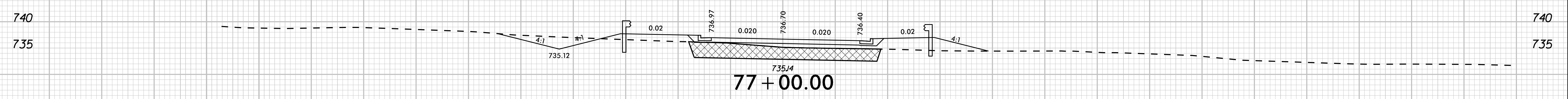

UNDERCUT
 SHALLOW UNDERCUT

-L- NORTHCROSS DRIVE

4/22/2024 K:\CHL_PROJ\01036359 - U-5108 (Northcross) DSM\Roadway\XSCU-5108_roy_xpl.dgn

140 130 120 110 100 90 80 70 60 50 40 30 20 10 0 10 20 30 40 50 60 70 80 90 100 110 120 130 140

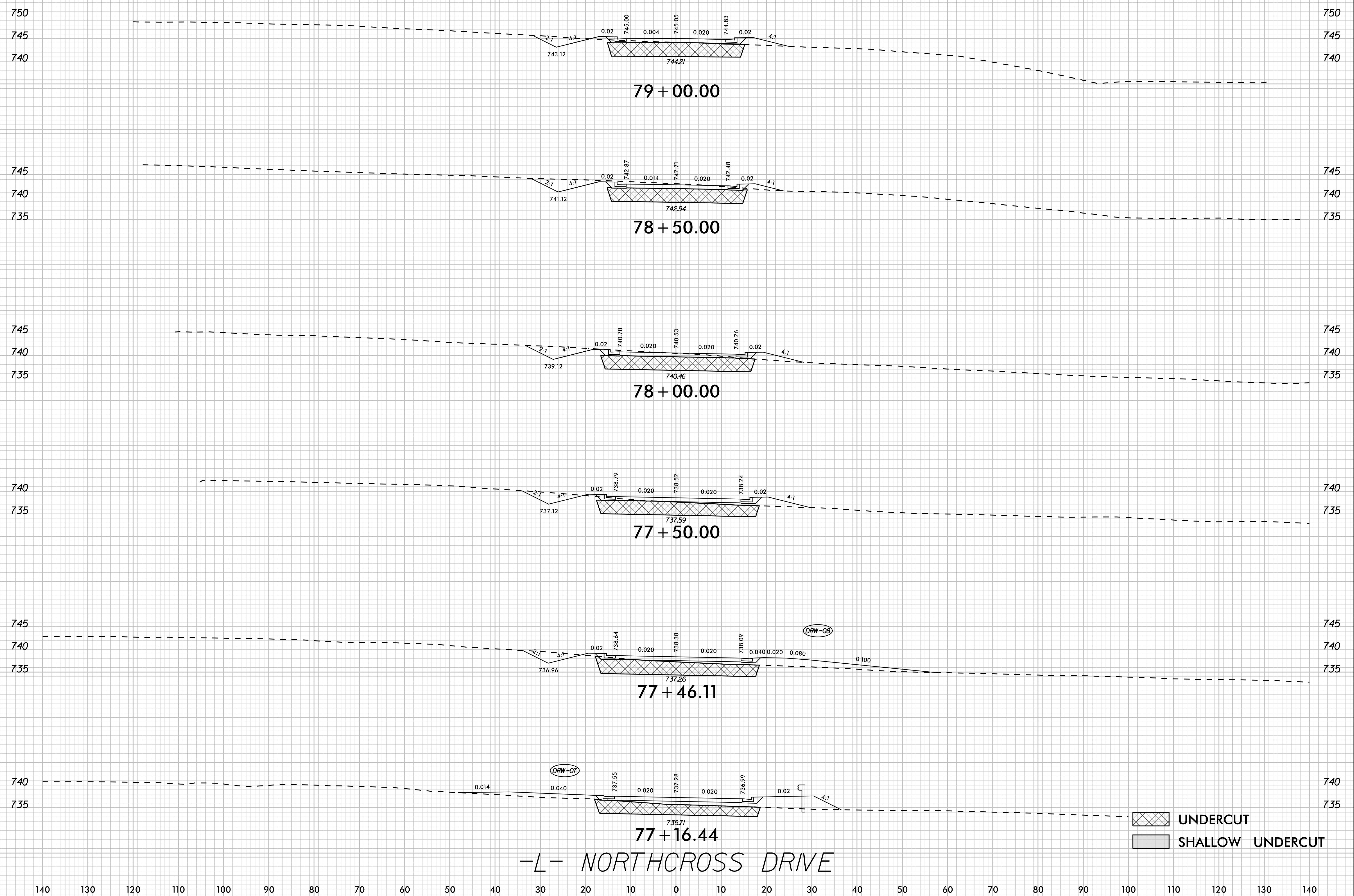

UNDERCUT
 SHALLOW UNDERCUT

-L- NORTHCROSS DRIVE

4/22/2024 K:\CHL_P\01036359 - U-5108 (Northcross) DSN\Roadway\XSCU-5108_rdy_xpl.dgn

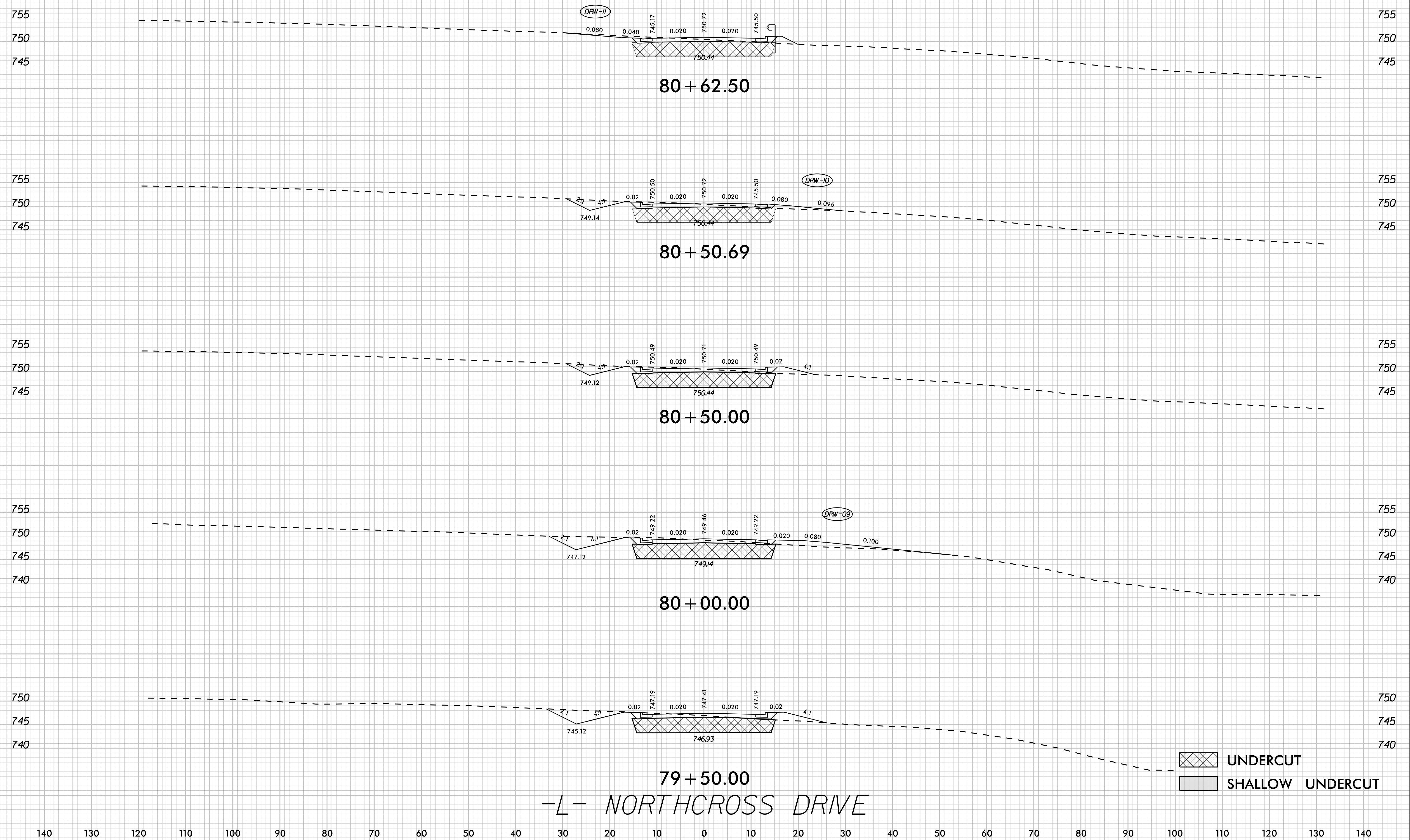

4/22/2024 K:\CHL_PROJ\01036359 - U-5108 (Northcross) DSN\Roadway\SCU-5108_roy_xpl.dgn

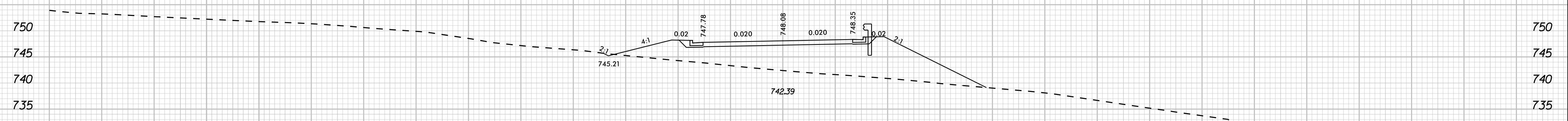

83 + 00.00

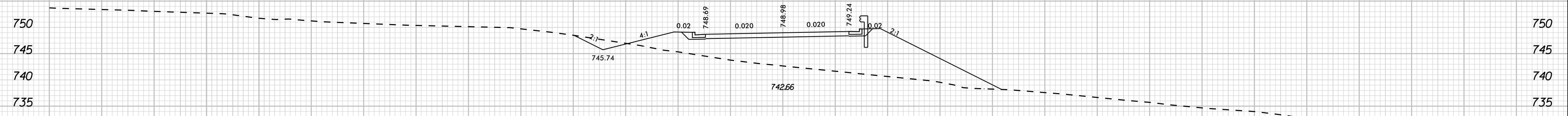

82 + 50.00

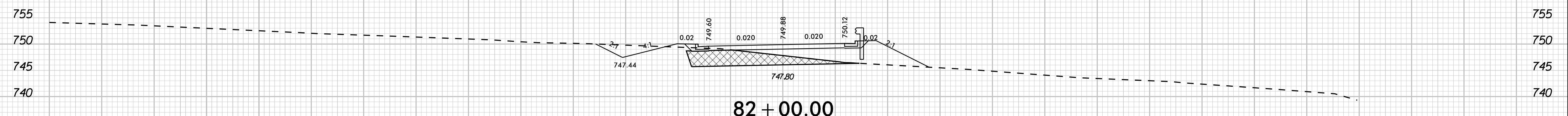

82 + 00.00

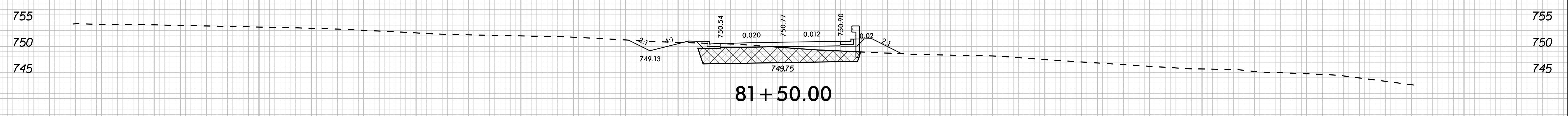

81 + 50.00

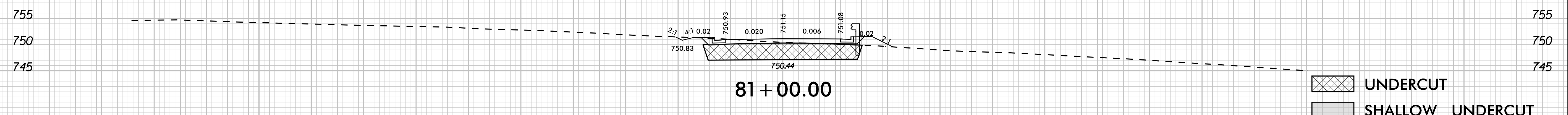

81 + 00.00

UNDERCUT
 SHALLOW UNDERCUT

-L- NORTHCROSS DRIVE

4/22/2024 K:\CHL_PROJ\01036359 - U-5108 (Northcross) DSN\Roadway\XSCU-5108_roy_xpl.dgn

140 130 120 110 100 90 80 70 60 50 40 30 20 10 0 10 20 30 40 50 60 70 80 90 100 110 120 130 140

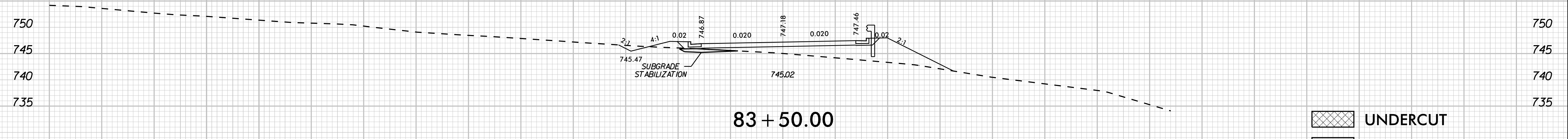
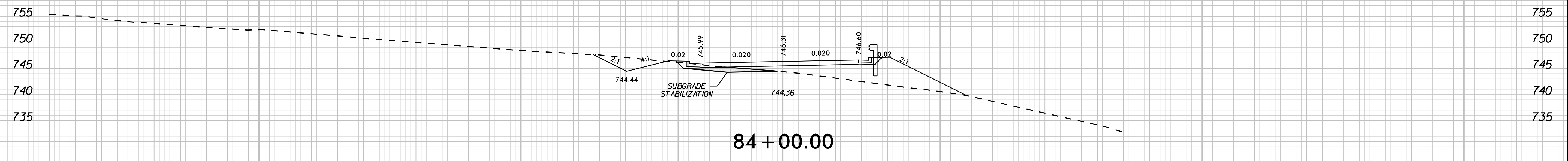
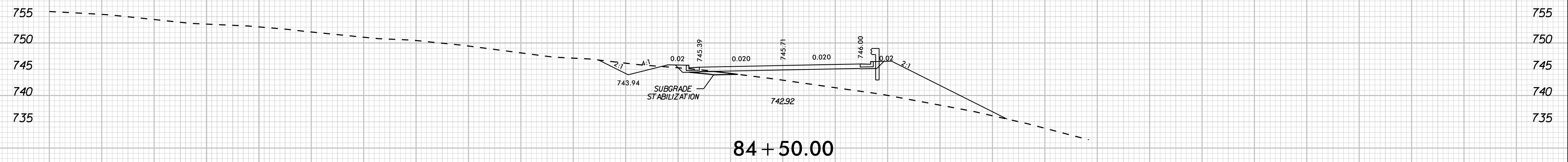
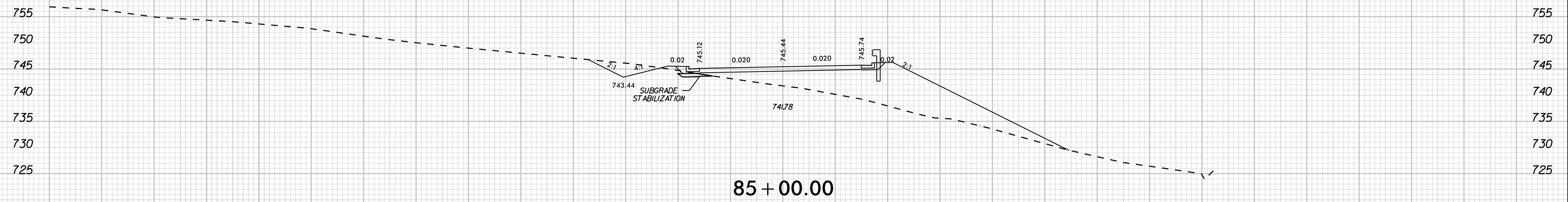

-L- NORTHCROSS DRIVE

UNDERCUT
 SHALLOW UNDERCUT

K:\CHL_PROJ\01036359 - U-5108 (Northcross) DSN\Roadway\SCU-5108_roy_xpl.dgn 4/22/2024

140 130 120 110 100 90 80 70 60 50 40 30 20 10 0 10 20 30 40 50 60 70 80 90 100 110 120 130 140

K:\CHL_PRJ\01036359 - U-5108 (Northcross) DSM\Roadway\XSCU-5108_roy_xpl.dgn
 4/22/2024

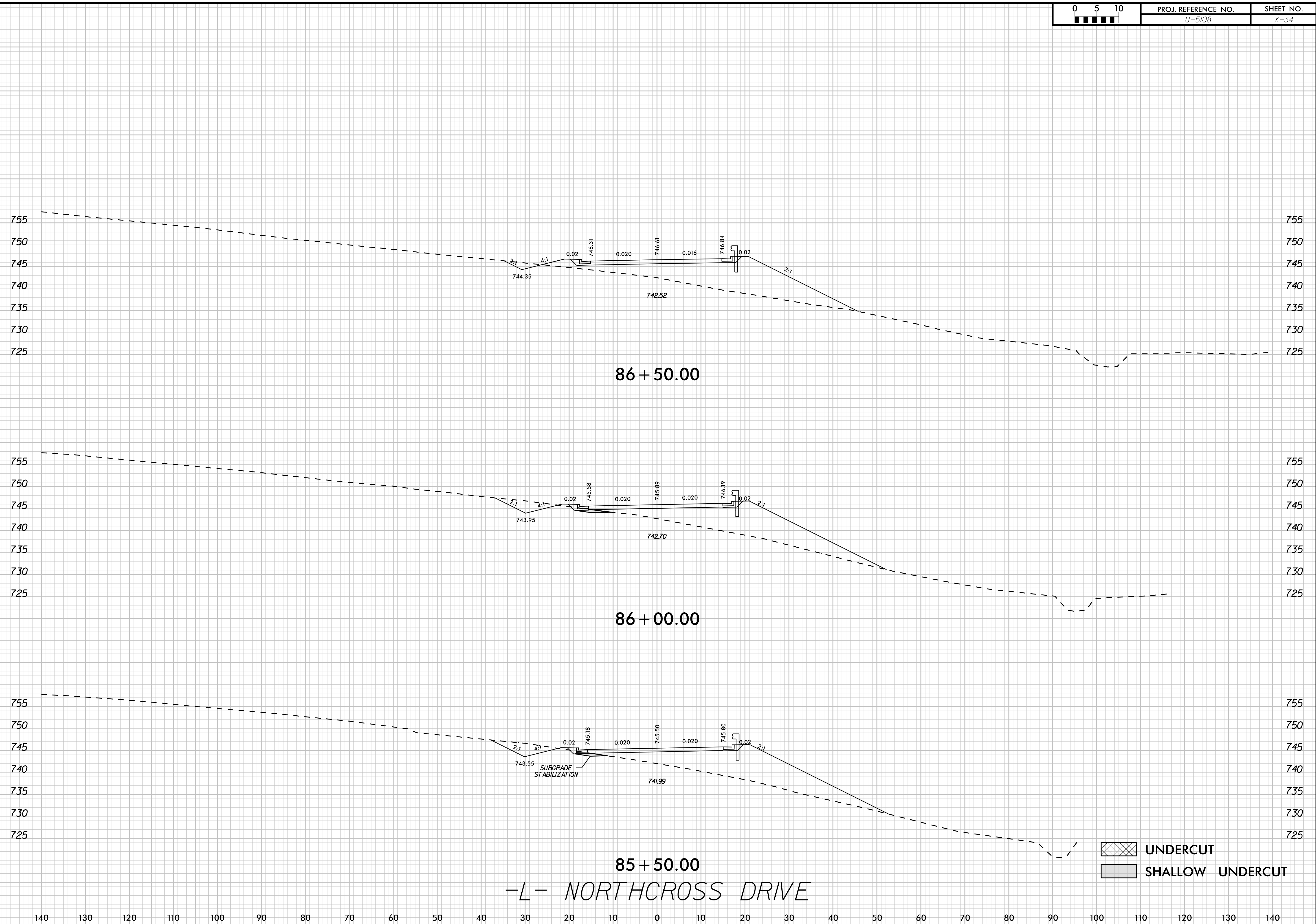

86 + 50.00
 86 + 00.00
 85 + 50.00
 -L- NORTHCROSS DRIVE

K:\CHL_PRJ\01036359 - U-5108 (Northcross) DSN\Roadway\XSCU-5108_roy_xpl.dgn
 4/22/2024

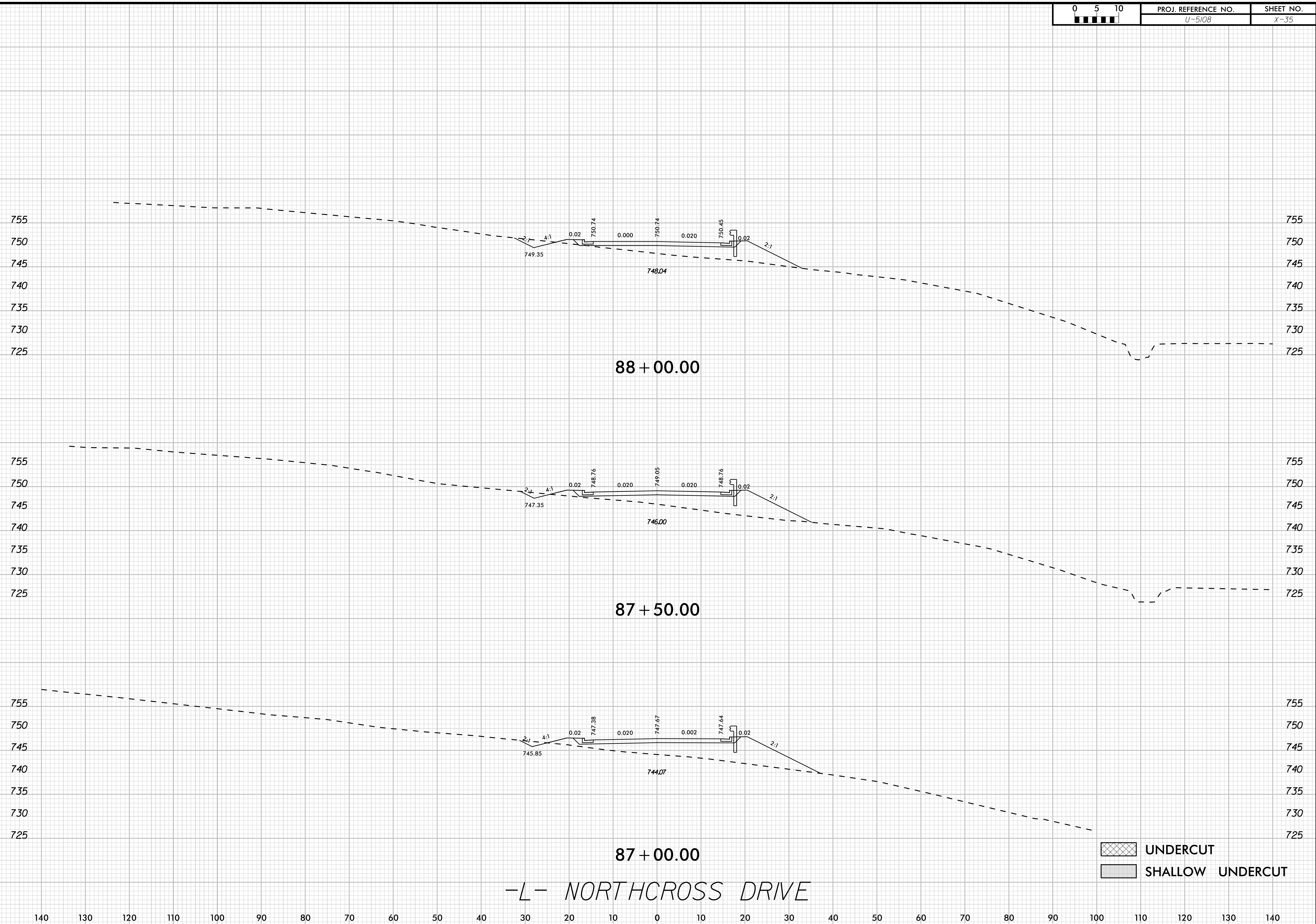

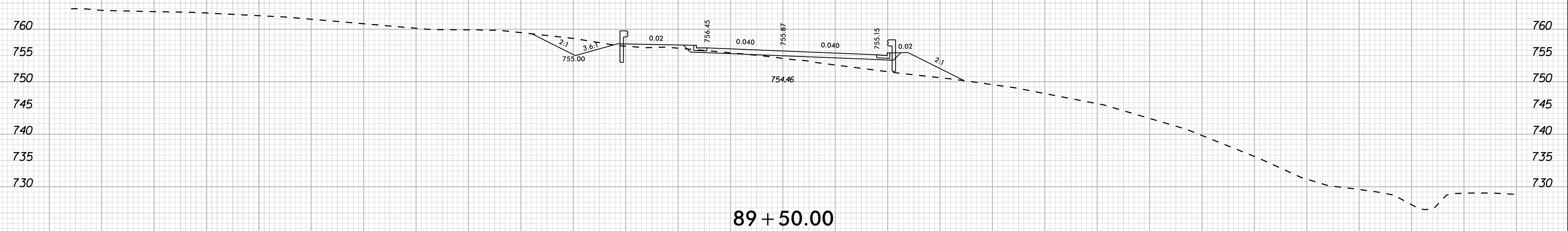

89 + 50.00

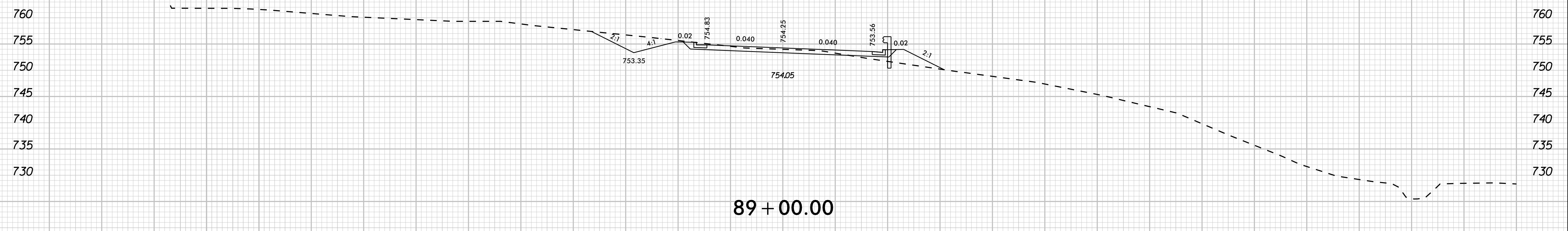

89 + 00.00

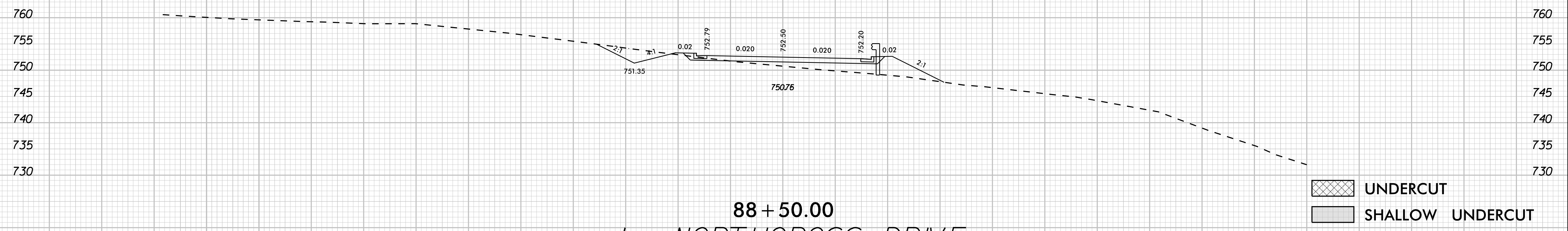

88 + 50.00

-L- NORTHCROSS DRIVE

UNDERCUT
 SHALLOW UNDERCUT

K:\CHL_PRJ\01036359 - U-5108 (Northcross) DSM\Roadway\XSCU-5108_roy_xpl.dgn 4/22/2024

K:\CHL_PRJ\01036359 - U-5108 (Northcross) DSM\Roadway\XSCU-5108_roy_xpl.dgn
 4/22/2024

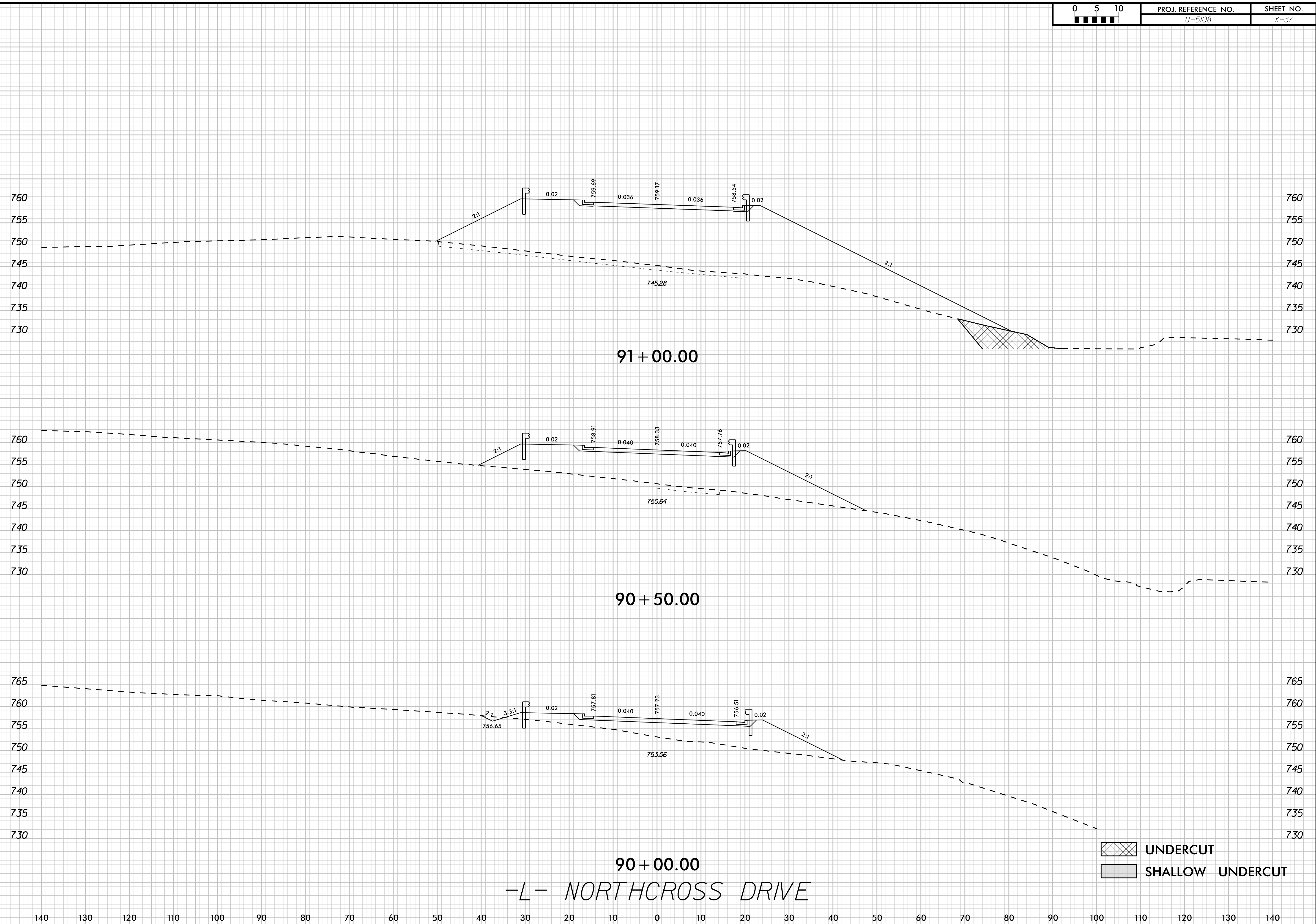

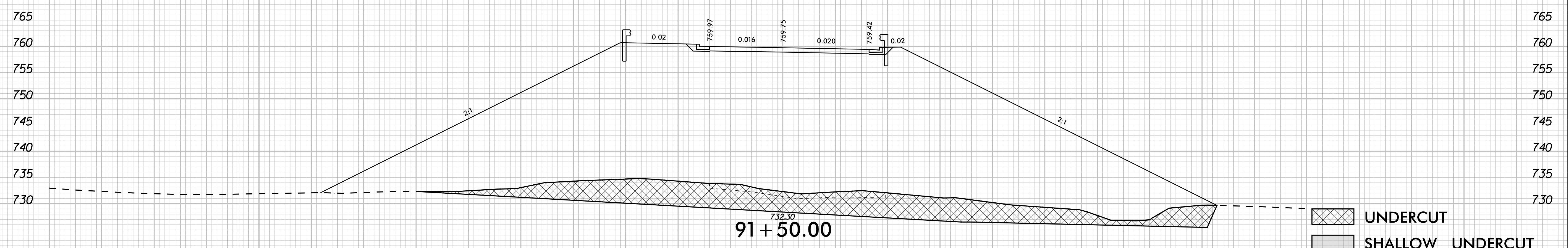
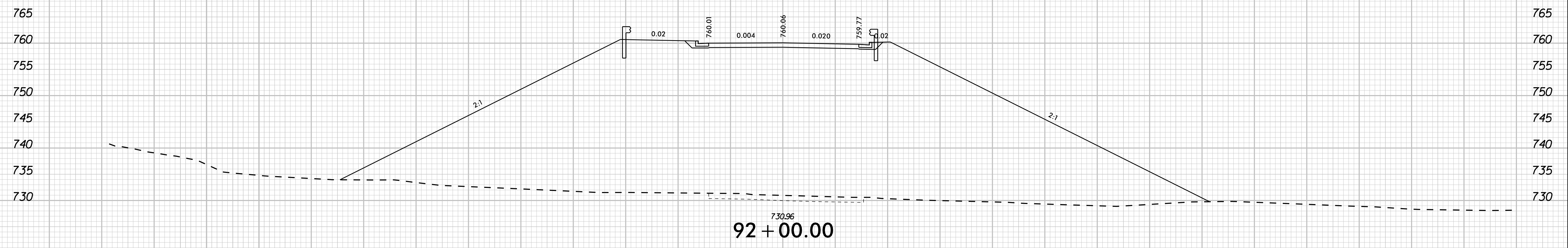
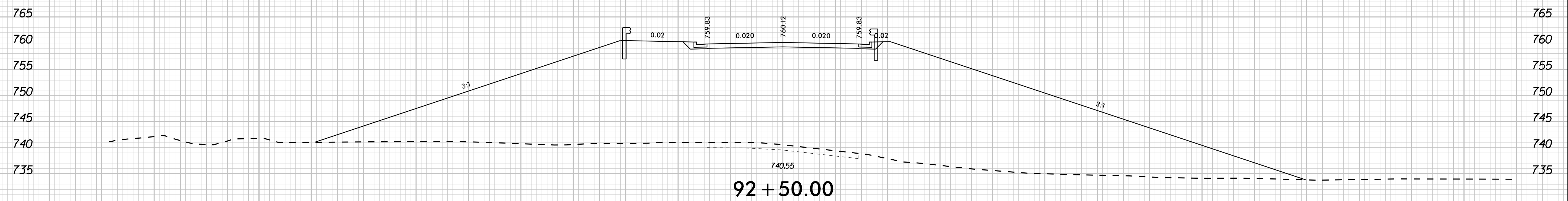

-L- NORTHCROSS DRIVE

K:\CHL_PRJ\01036359 - U-5108 (Northcross) DSN\Roadway\XSCU-5108_roy_xpl.dgn 4/22/2024

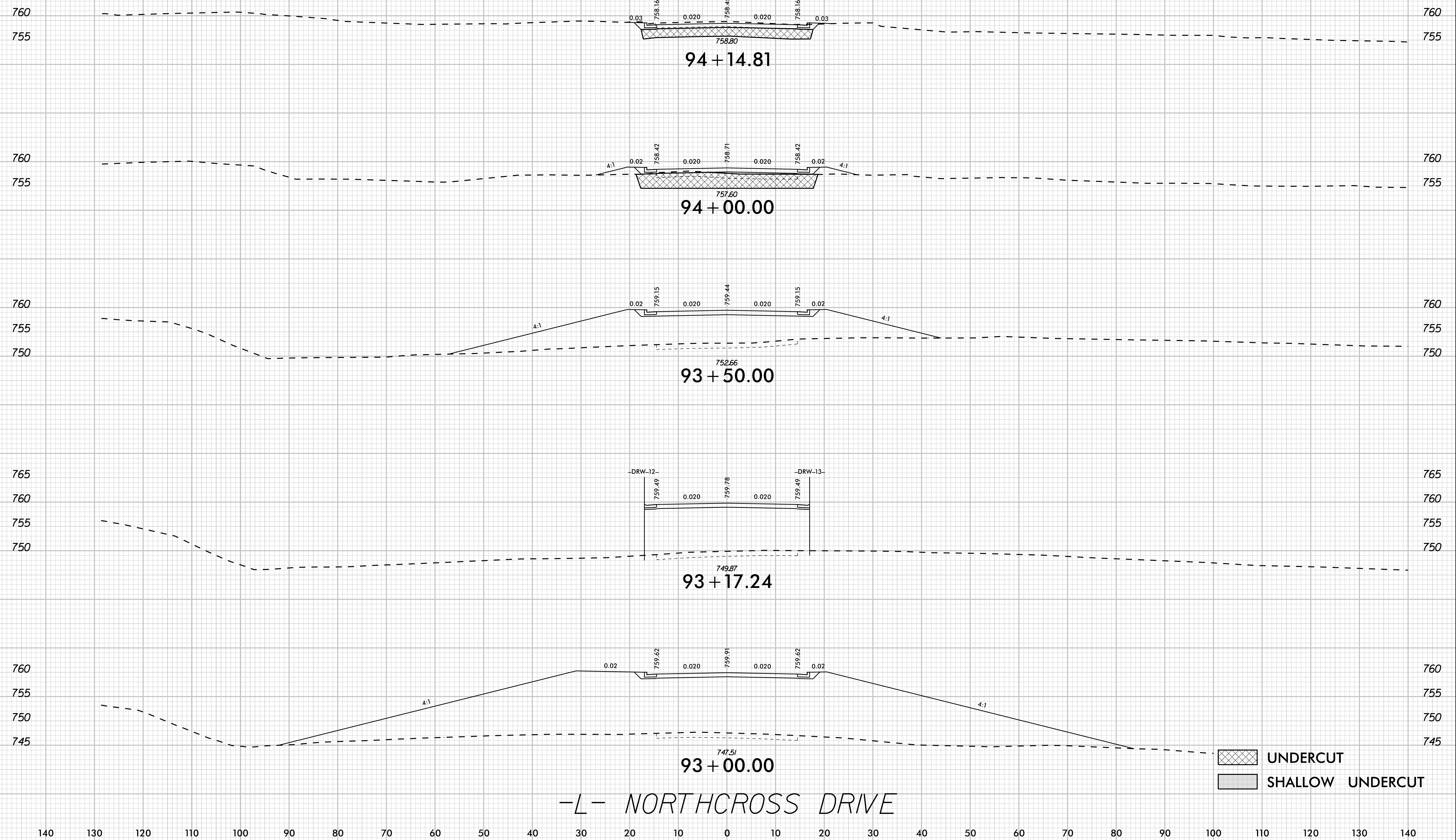

-L- NORTHCROSS DRIVE

UNDERCUT
 SHALLOW UNDERCUT

K:\CHL_PROJ\01036359 - U-5108 (Northcross)\DSM\Roadway\XSCU-5108_roy_xpl.dgn
 4/22/2024

K:\CHL_PROJ\01036359 - U-5108 (Northcross) DSN\Roadway\XSCU-5108_roy_xpl.dgn
 4/22/2024

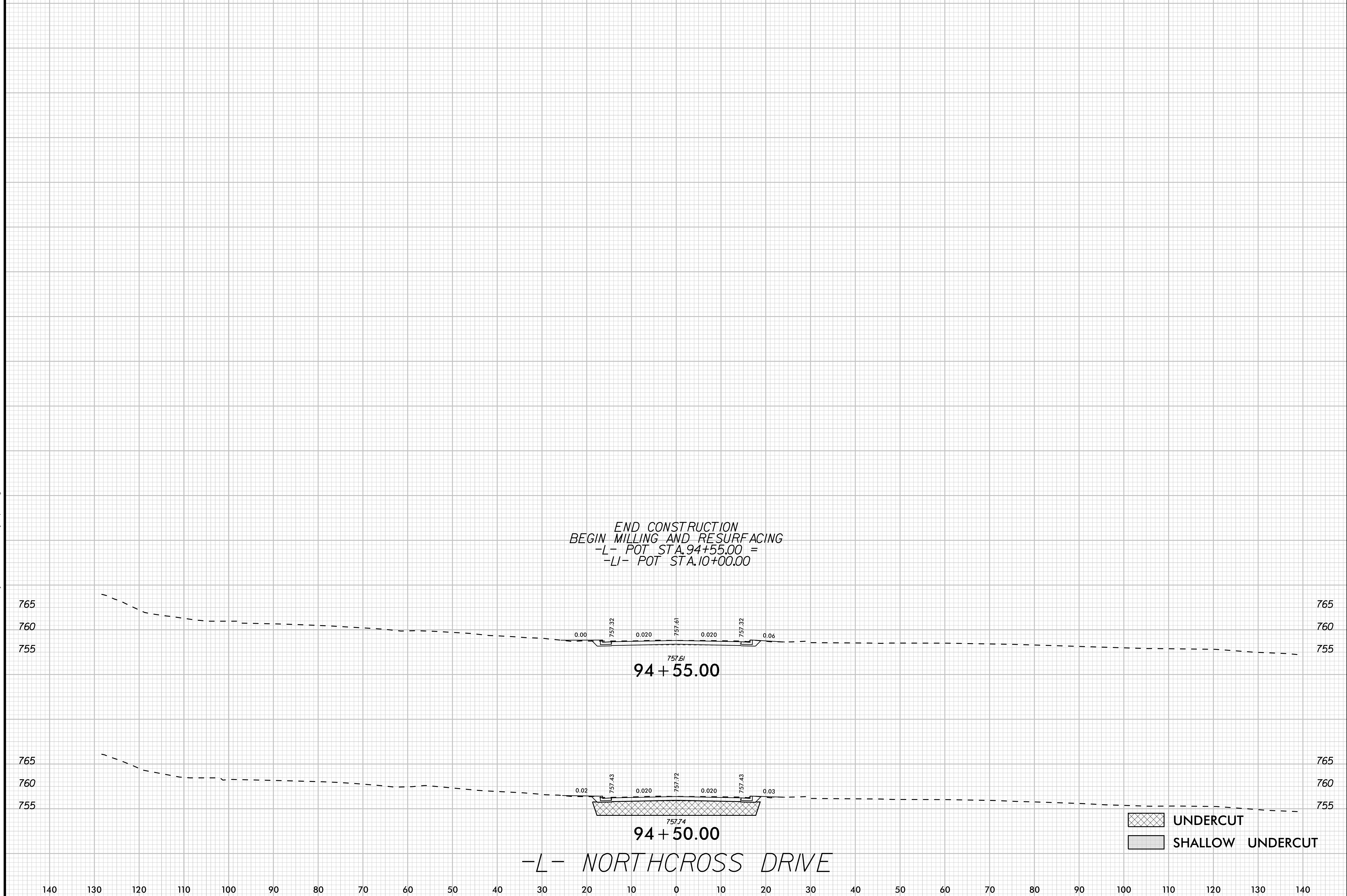

END CONSTRUCTION
 BEGIN MILLING AND RESURFACING
 -L- POT STA. 94+55.00 =
 -LI- POT STA. 10+00.00

-L- NORTH CROSS DRIVE

UNDERCUT
 SHALLOW UNDERCUT

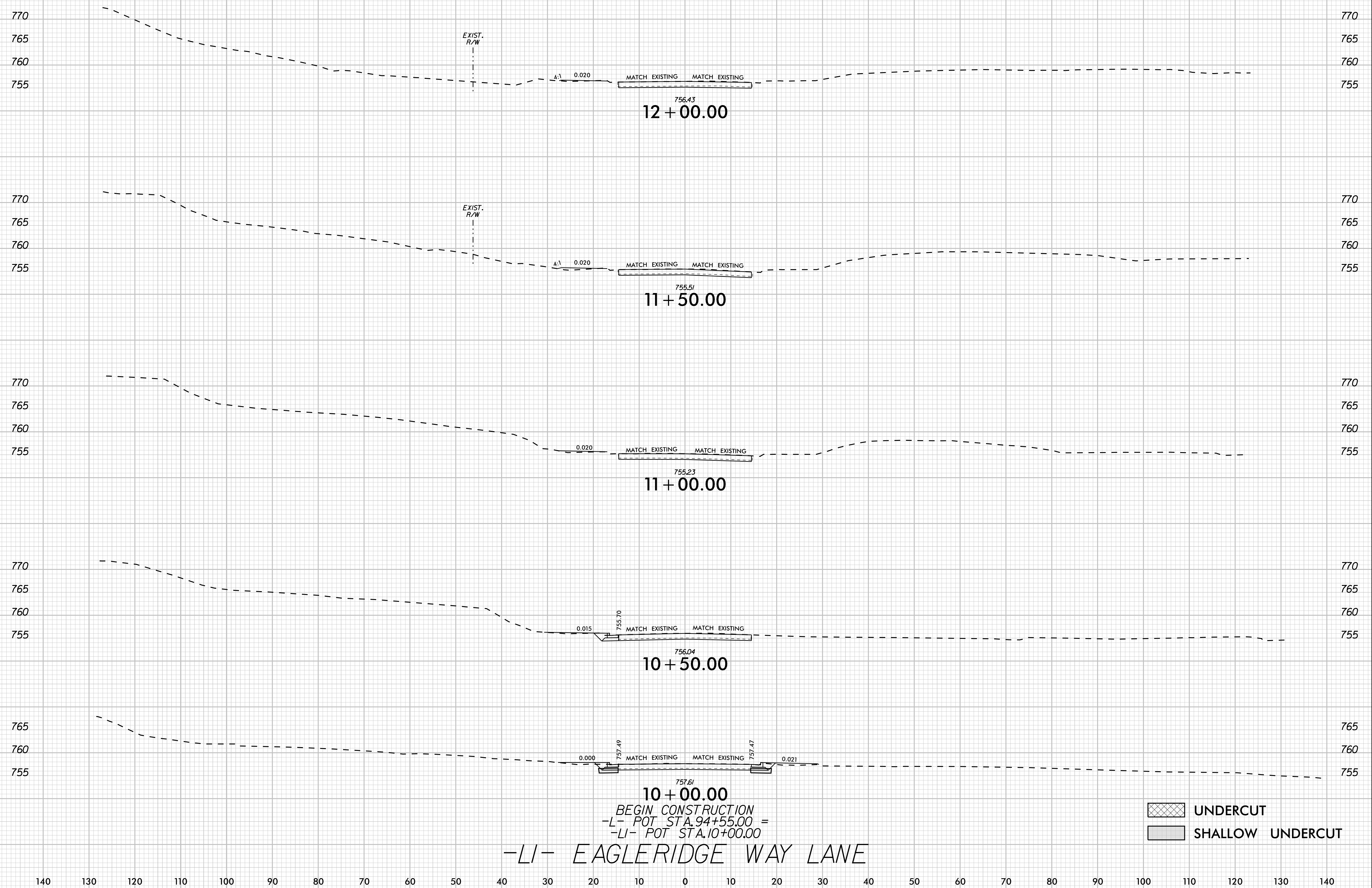

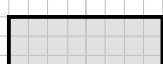
 UNDERCUT
 SHALLOW UNDERCUT

-LI- EAGLERIDGE WAY LANE
 BEGIN CONSTRUCTION
 -L- POT STA. 94+55.00 =
 -LI- POT STA. 10+00.00

4/22/2024 K:\CHL_PROJ\01036359 - U-5108 (Northcross) DSN\Roadway\XSCU-5108_roy_xp_L1.dgn

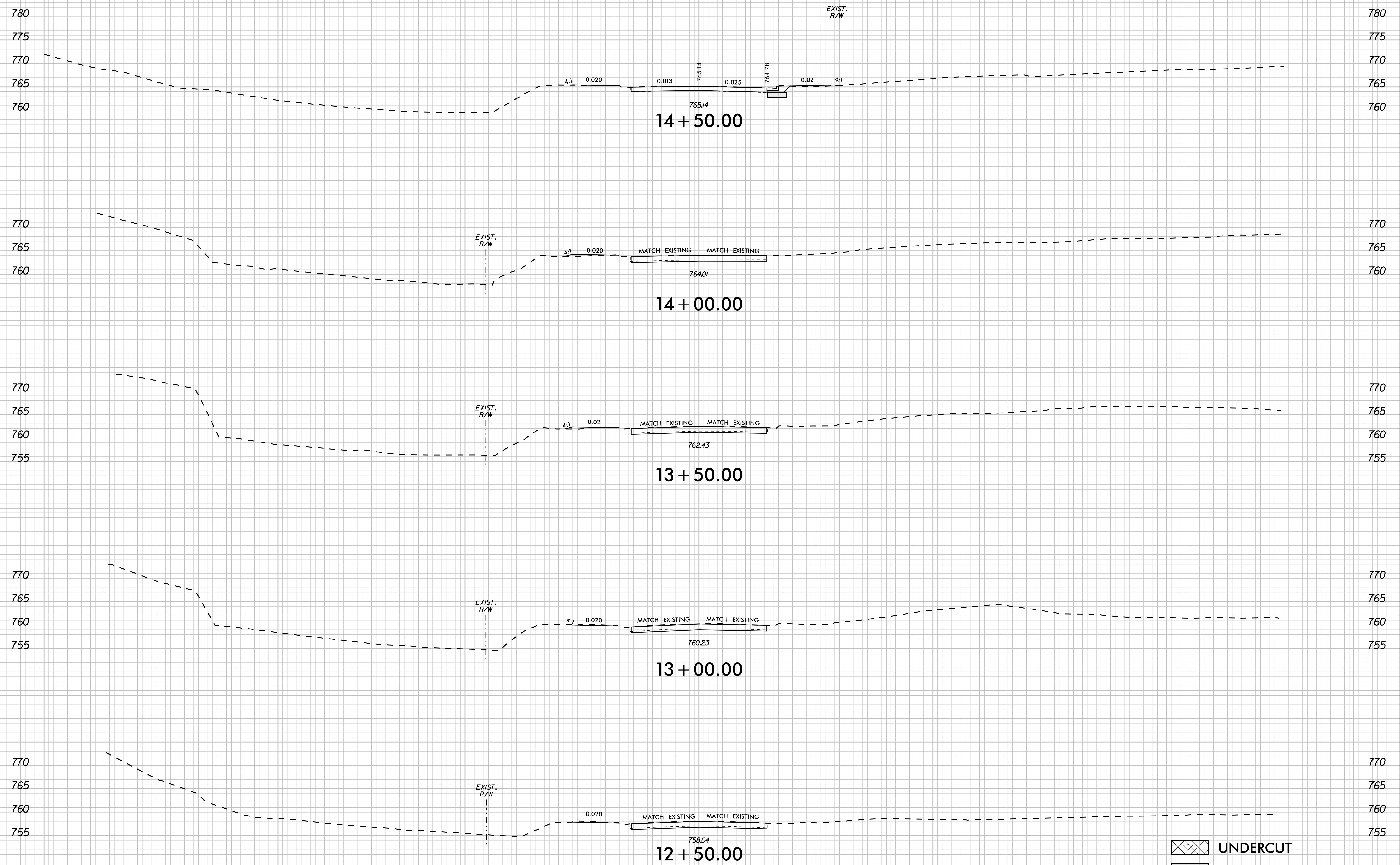

UNDERCUT
 SHALLOW UNDERCUT

-LI- EAGLERIDGE WAY LANE

4/22/2024 K:\CHL_PROJ\01036359 - U-5108 (Northcross) DSN\Roadway\XSCU-5108_roy_xp_L1.dgn

140 130 120 110 100 90 80 70 60 50 40 30 20 10 0 10 20 30 40 50 60 70 80 90 100 110 120 130 140

K:\CHL_PRJ\01036359 - U-5108 (Northcross) DSN\Roadway\XSCU-5108_roy_xpl.dgn
4/22/2024

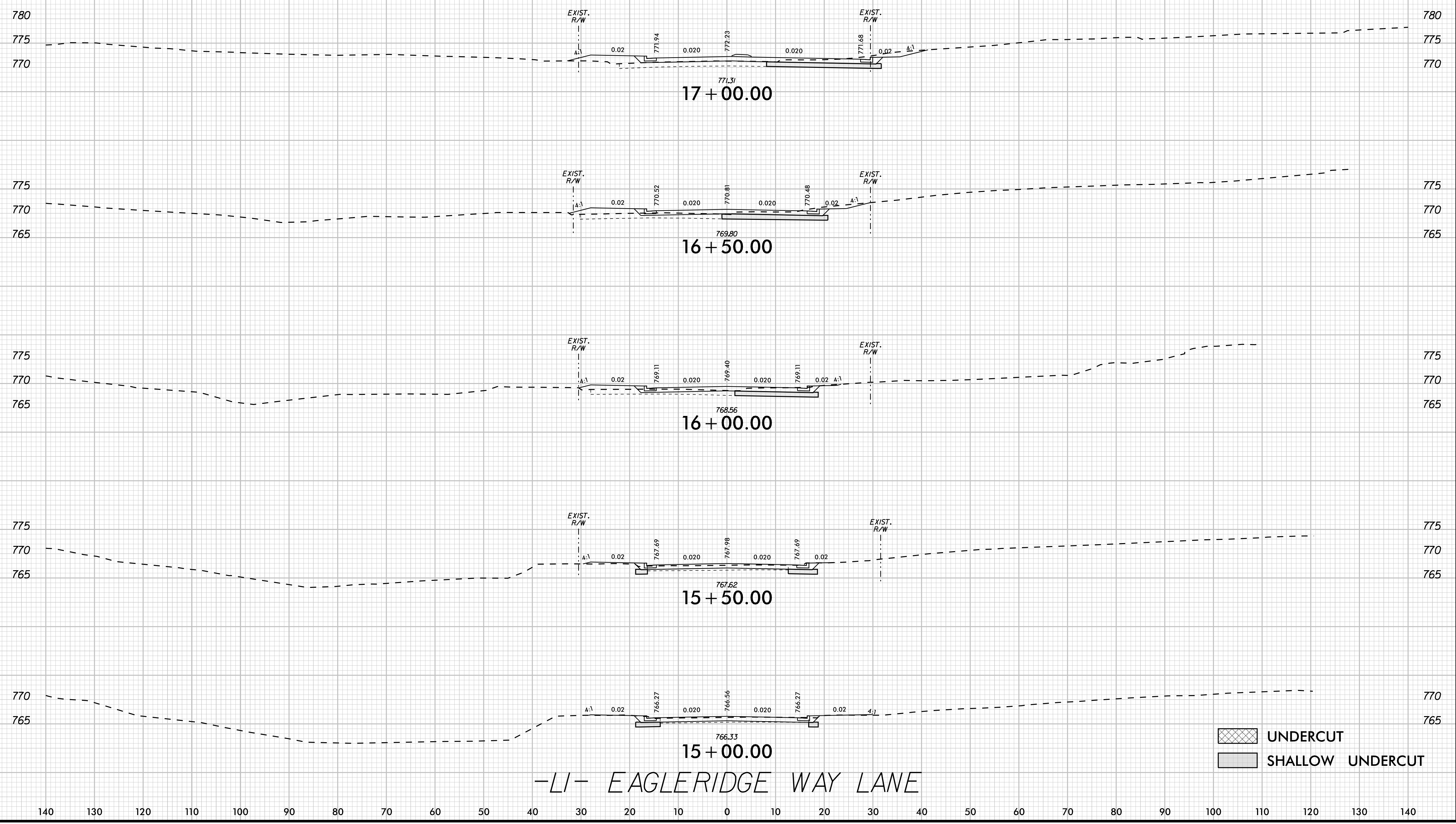

-LI- EAGLERIDGE WAY LANE

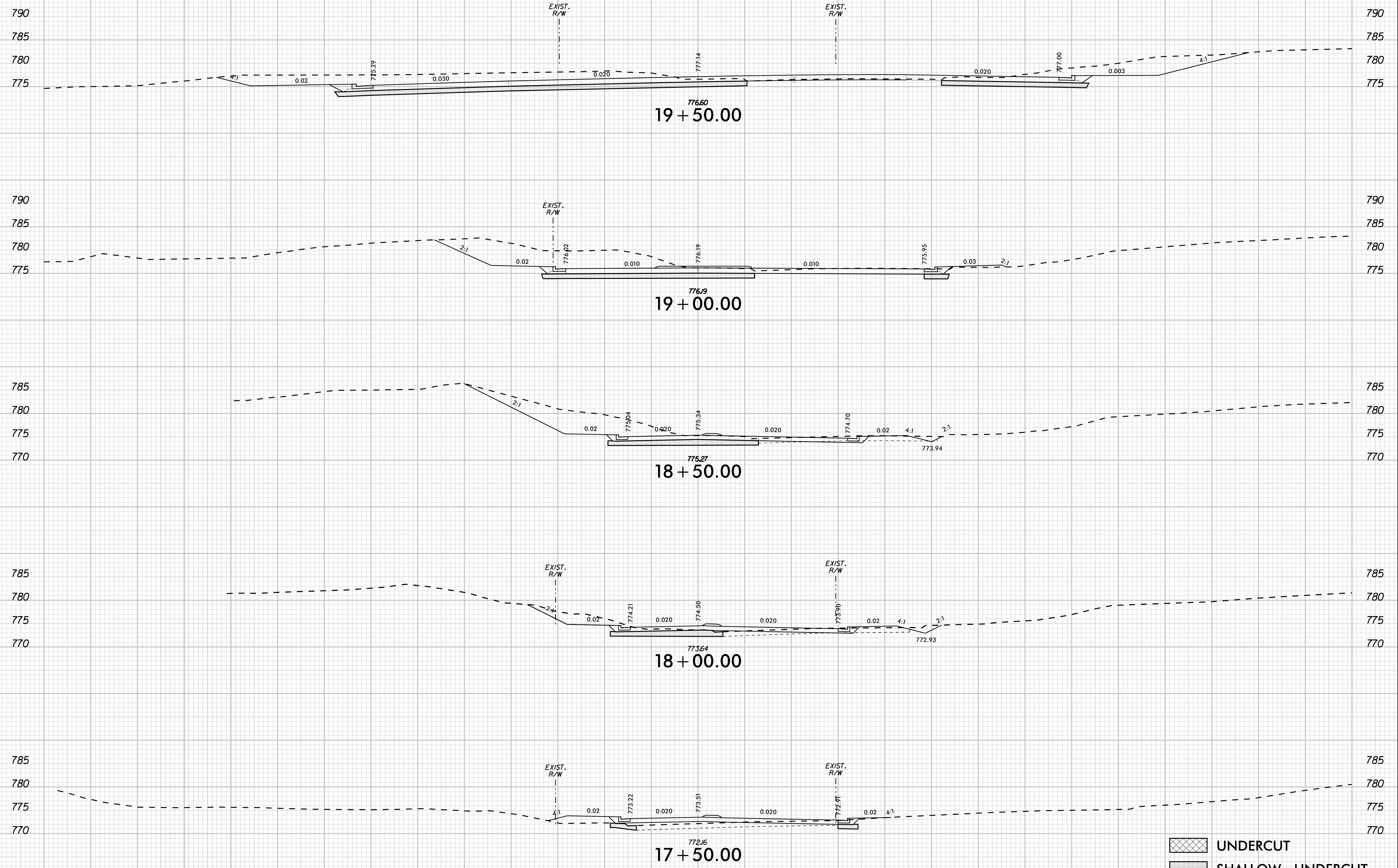

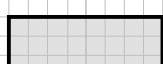
 UNDERCUT
 SHALLOW UNDERCUT

-LI- EAGLERIDGE WAY LANE

4/22/2024 K:\CHL_PROJ\01036359 - U-5108 (Northcross) DSN\Roadway\XSCU-5108_roy_xp_L1.dgn

140 130 120 110 100 90 80 70 60 50 40 30 20 10 0 10 20 30 40 50 60 70 80 90 100 110 120 130 140

END CONSTRUCTION
 -LI- POT STA.19+52.58 =
 -RAB- POT STA.10+00.00 =
 -RAB- POT STA.13+64.33

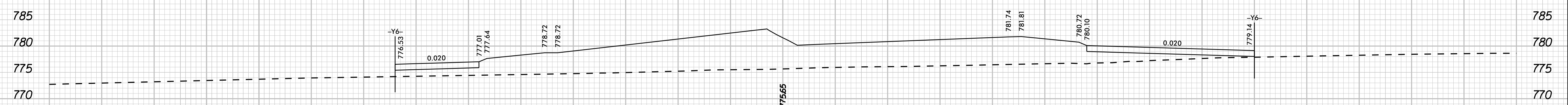

20+10.59

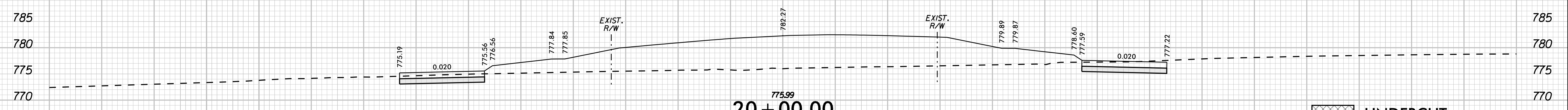

20+00.00

-LI- EAGLERIDGE WAY LANE

UNDERCUT
 SHALLOW UNDERCUT

K:\CHL_PROJ\01036359 - U-5108 (Northcross) DSN\Roadway\XSCU-5108_roy_xpl_L1.dgn 4/22/2024

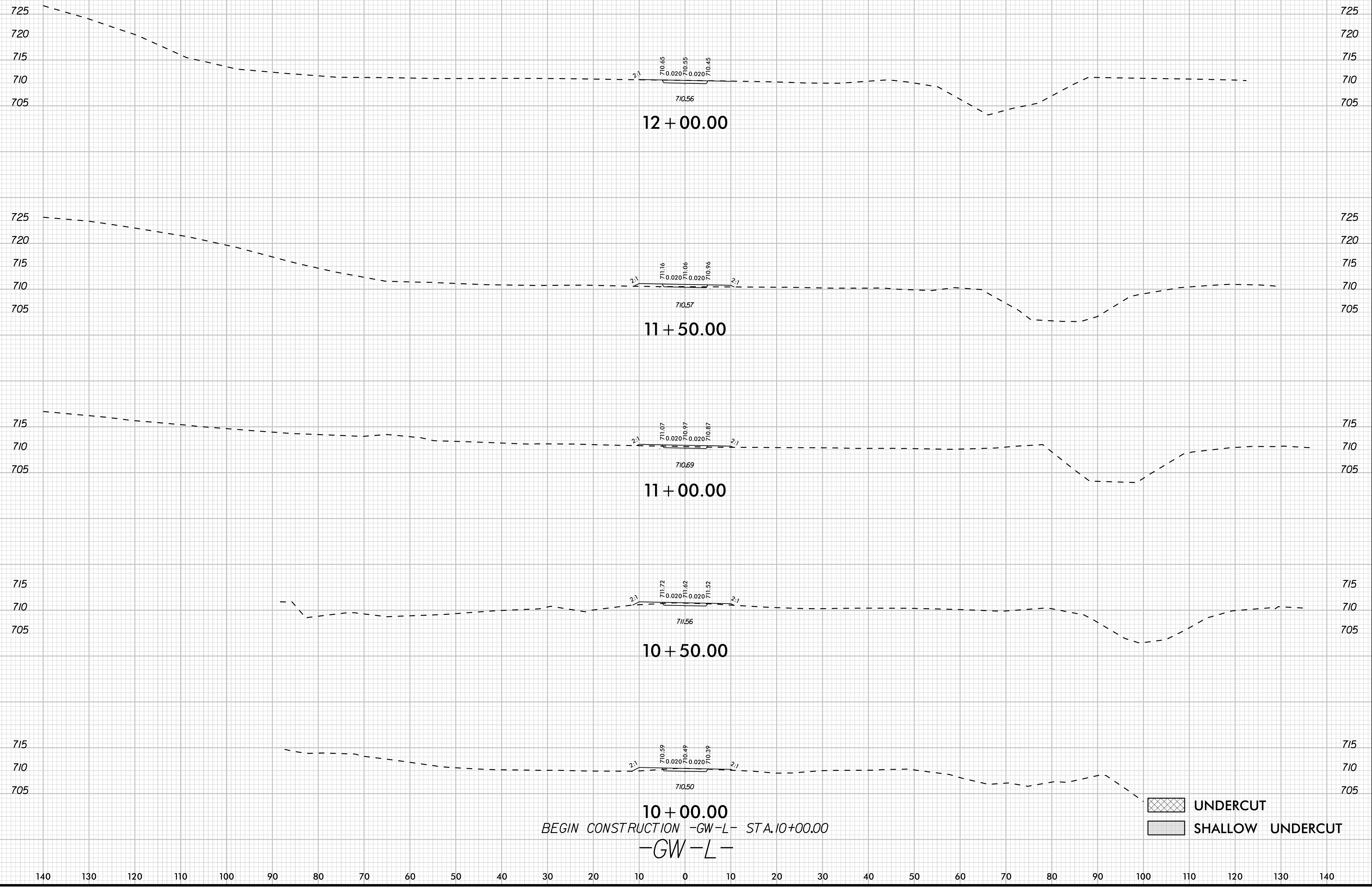

10 + 00.00
 BEGIN CONSTRUCTION -GW-L- STA.10+00.00
 -GW-L-

UNDERCUT
 SHALLOW UNDERCUT

3/12/2024 K:\CHL_PRJ\01036359 - U-5108 (Northcross) DSN\Roadway\XSCU-5108_roy_xpl_GW-L.dgn

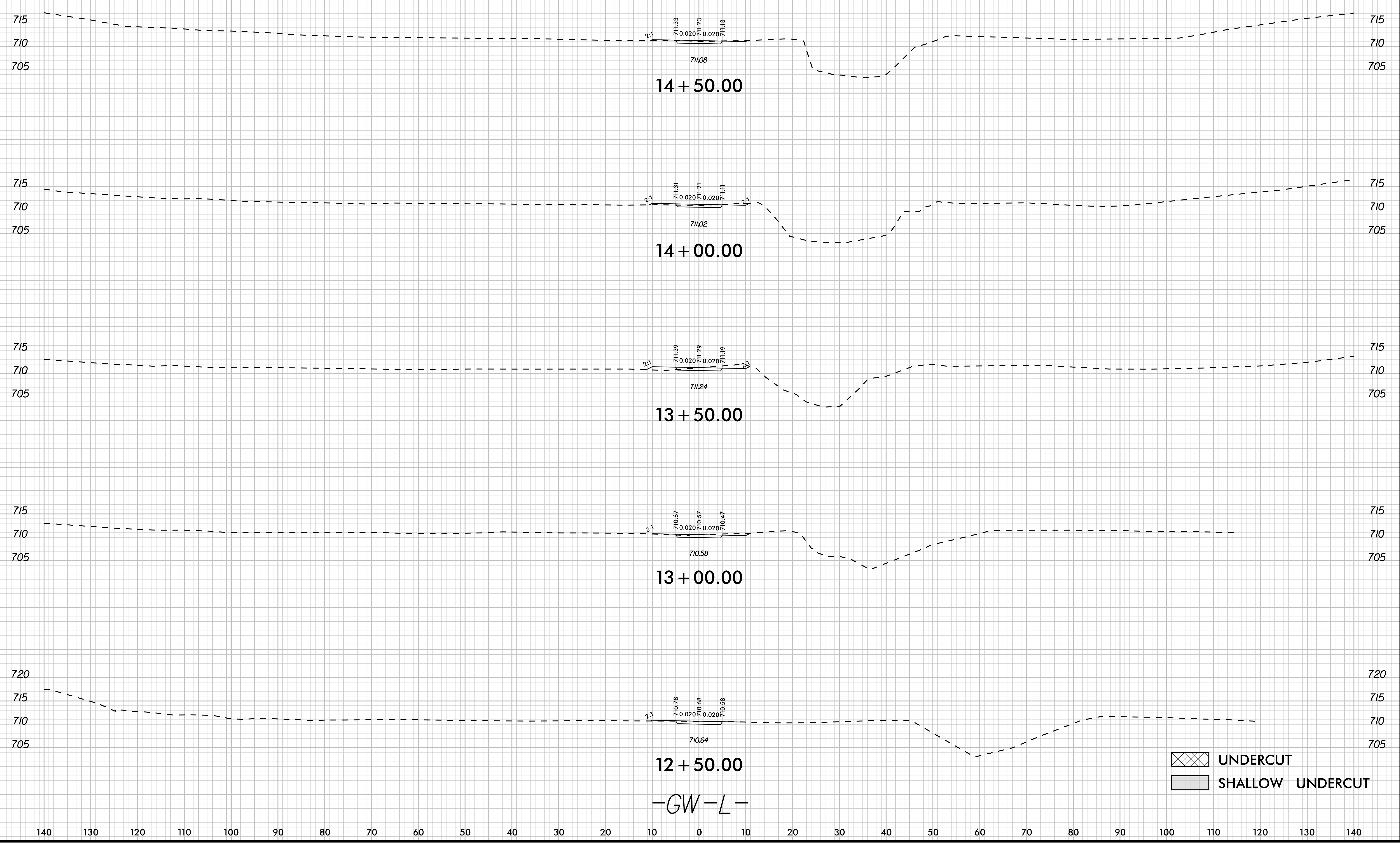

K:\CHL_PROJ\01036359 - U-5108 (Northcross) DSN\Roadway\XSCU-5108_roy_xpl_GW-L.dgn
 3/12/2024

-GW-L-

K:\CHL_PRJ\01036359 - U-5108 (Northcross) DSN\Roadway\XSCU-5108_roy_xpl_GW-L.dgn
 3/12/2024

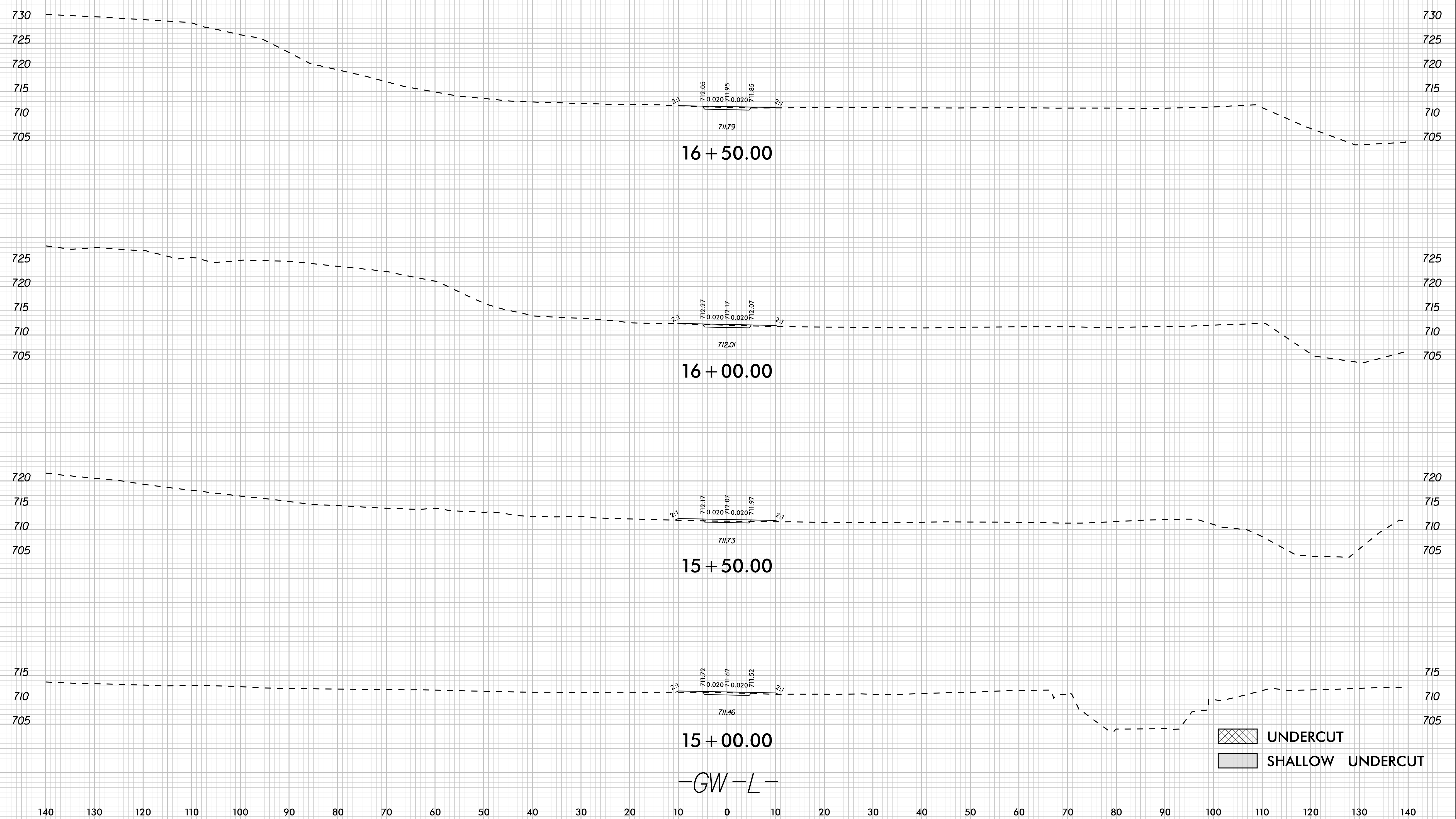

K:\CHL_PROJ\01036359 - U-5108 (Northcross) DSN\Roadway\XSCU-5108_roy_xpl_GW-L.dgn
3/12/2024

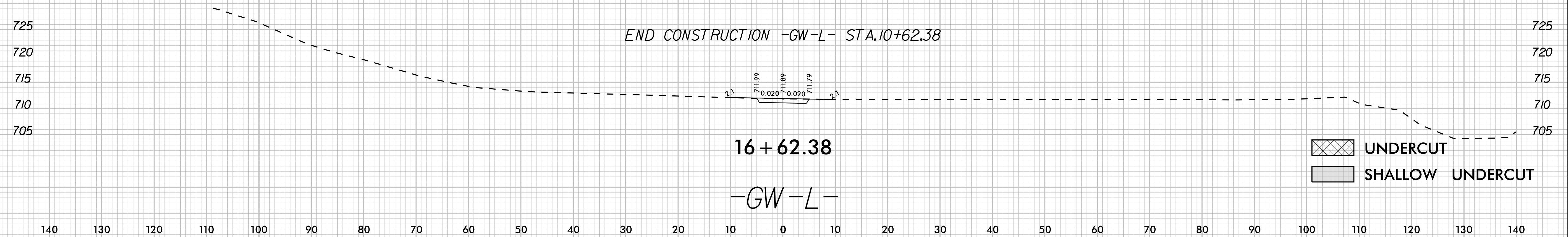

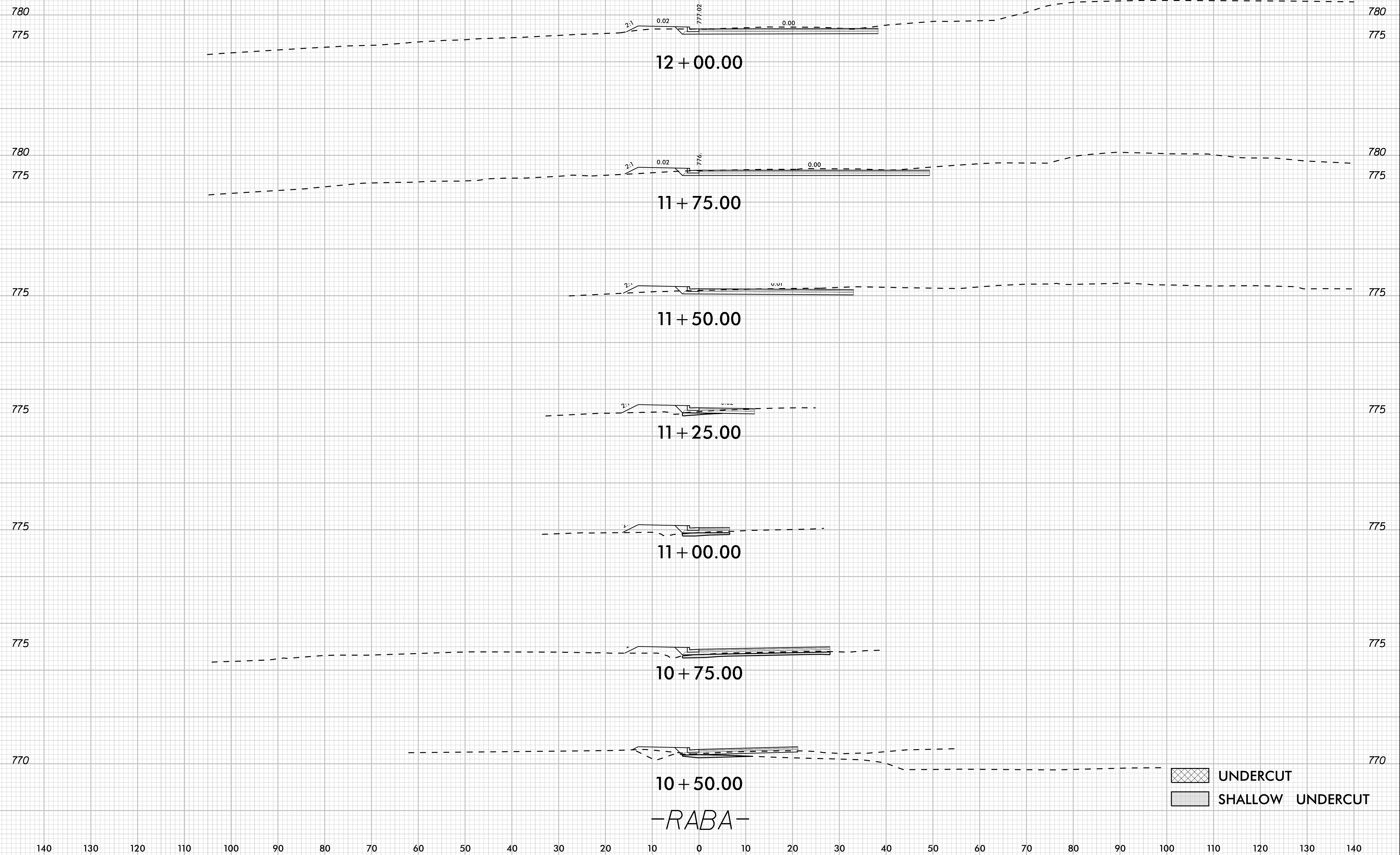

K:\CHL_PROJ\01036359 - U-5108 (Northcross)\DSM\Roadway\XSCU-5108_roy_xp_RABA.dgn
 3/12/2024

-RABA-

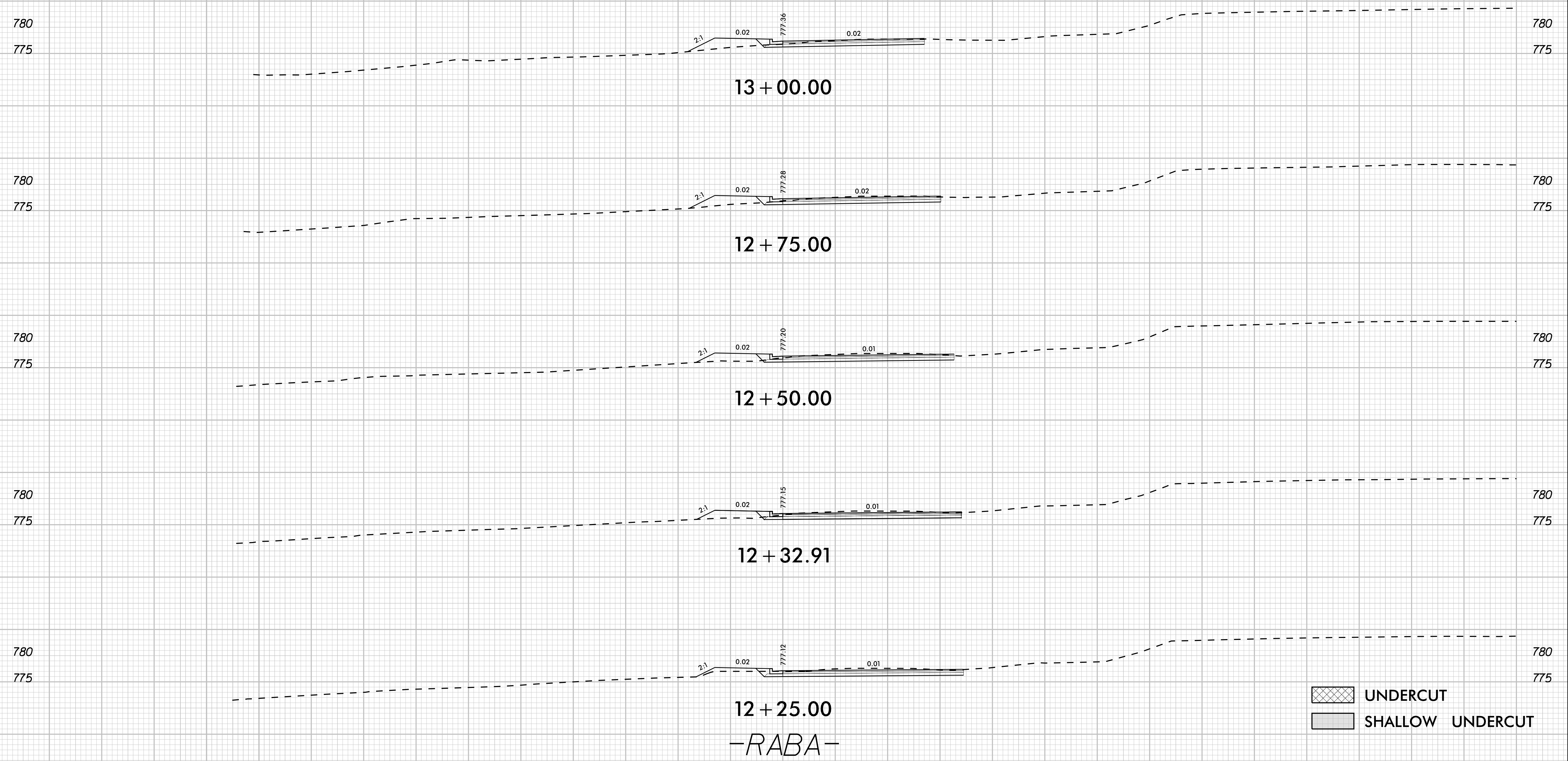

K:\CHL_PRJ\01036359 - U-5108 (Northcross)\DSM\Roadway\XSCU-5108_roy_xpl_RABA.dgn
 3/12/2024

140 130 120 110 100 90 80 70 60 50 40 30 20 10 0 10 20 30 40 50 60 70 80 90 100 110 120 130 140

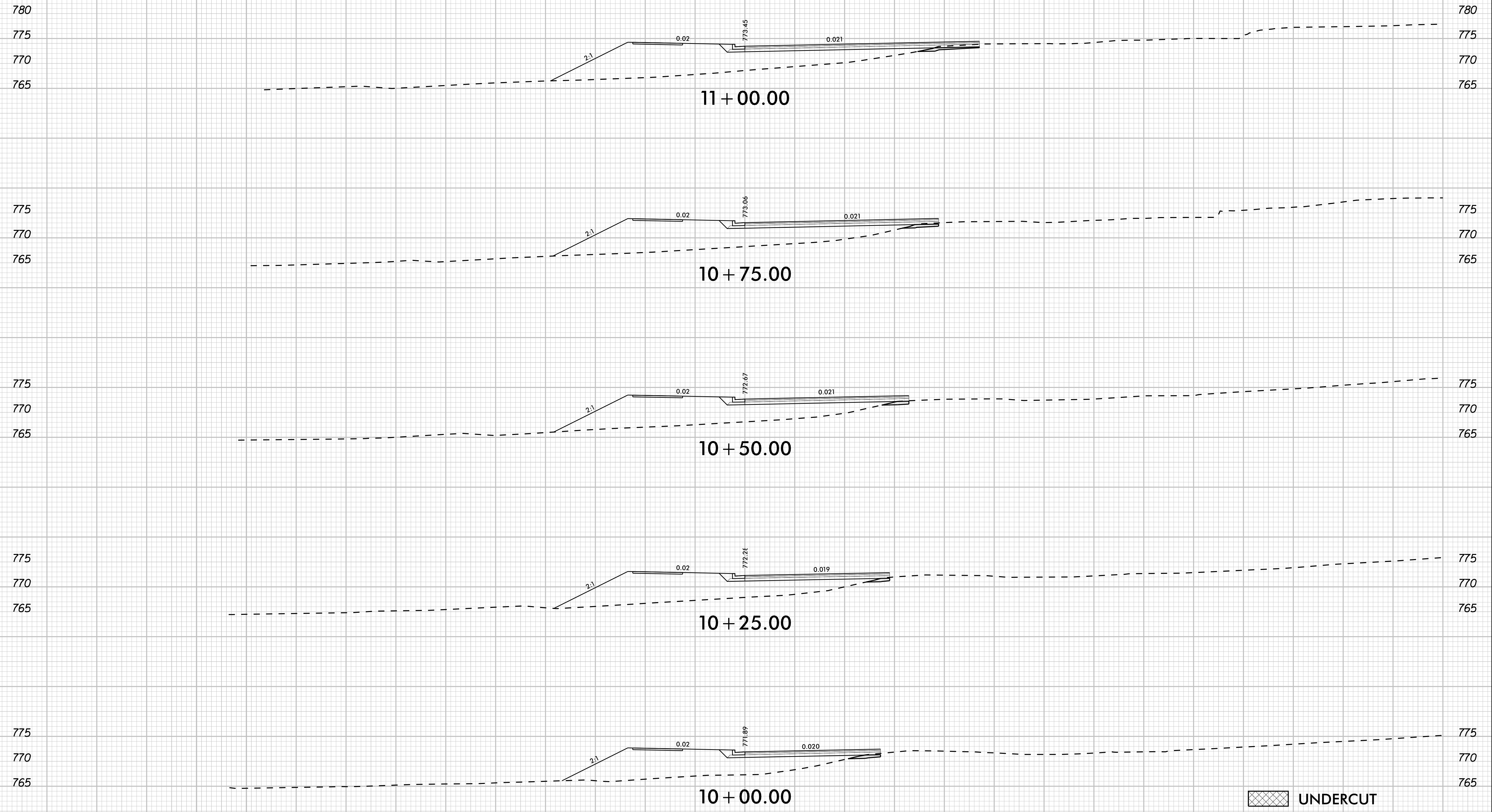

K:\CHL_PRJ\01036359 - U-5108 (Northcross) DSN\Roadway\XSCU-5108_roy_xp_RABB.dgn
 3/12/2024

140 130 120 110 100 90 80 70 60 50 40 30 20 10 0 10 20 30 40 50 60 70 80 90 100 110 120 130 140

-RABB-

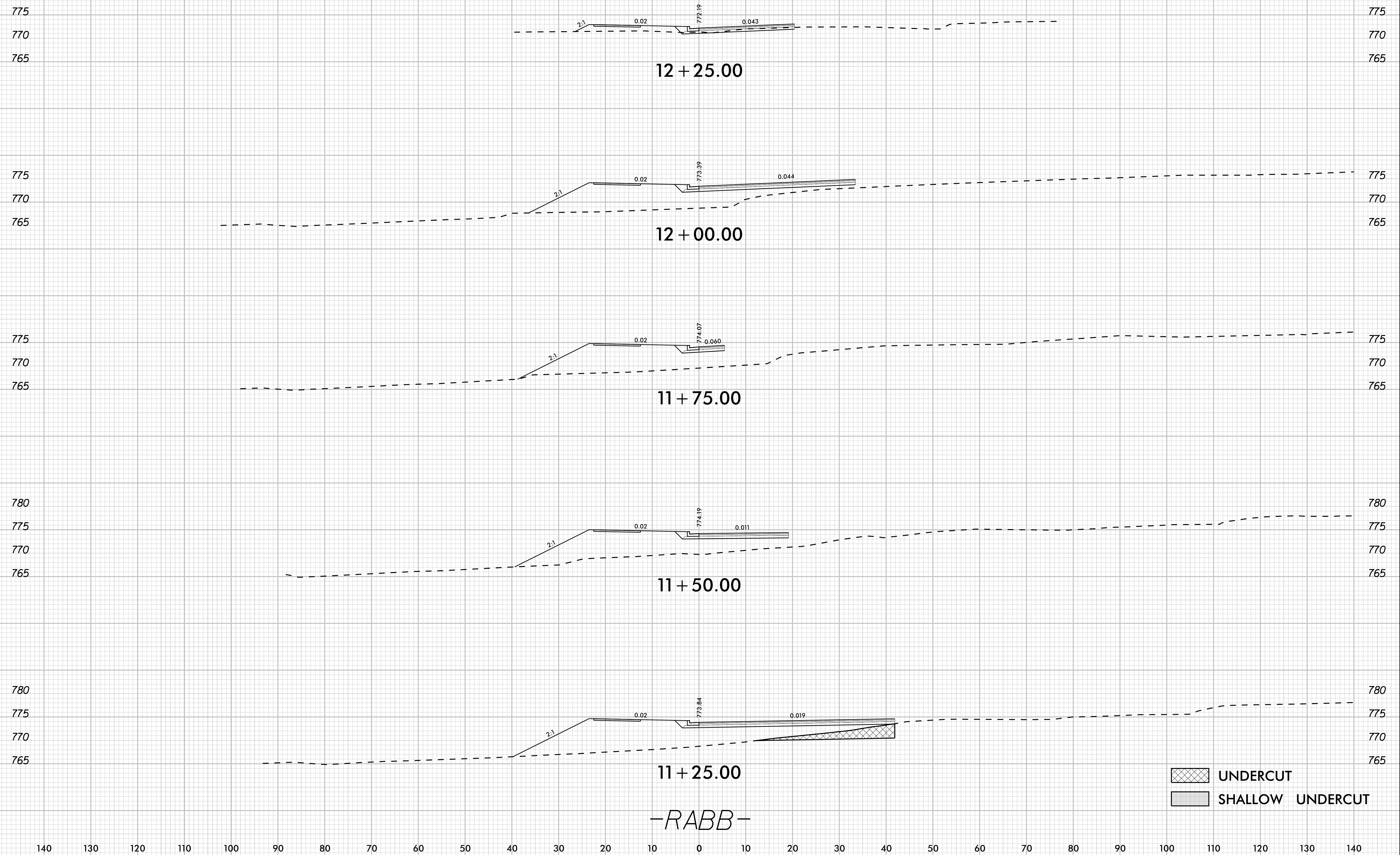

K:\CHL_PROJ\01036359 - U-5108 (Northcross) DSN\Roadway\XSCU-5108_roy_xp_RABB.dgn
 3/12/2024

-RABB-

K:\CHL_PROJ\01036359 - U-5108 (Northcross) DSN\Roadway\XSCU-5108_roy_xp_RABB.dgn
3/12/2024

780
775
770
765

780
775
770
765

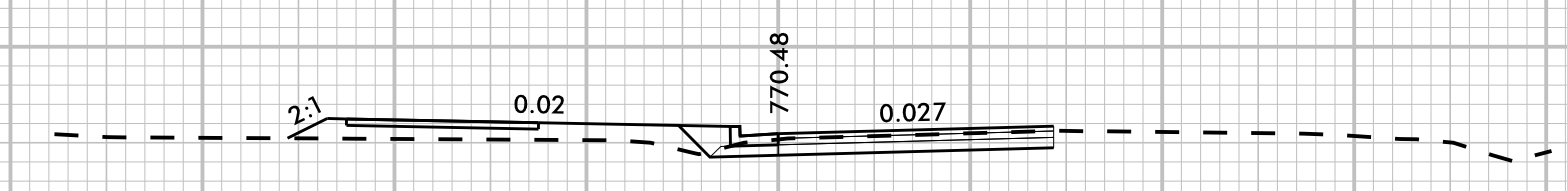

12 + 50.00

-RABB-

UNDERCUT
 SHALLOW UNDERCUT

140 130 120 110 100 90 80 70 60 50 40 30 20 10 0 10 20 30 40 50 60 70 80 90 100 110 120 130 140

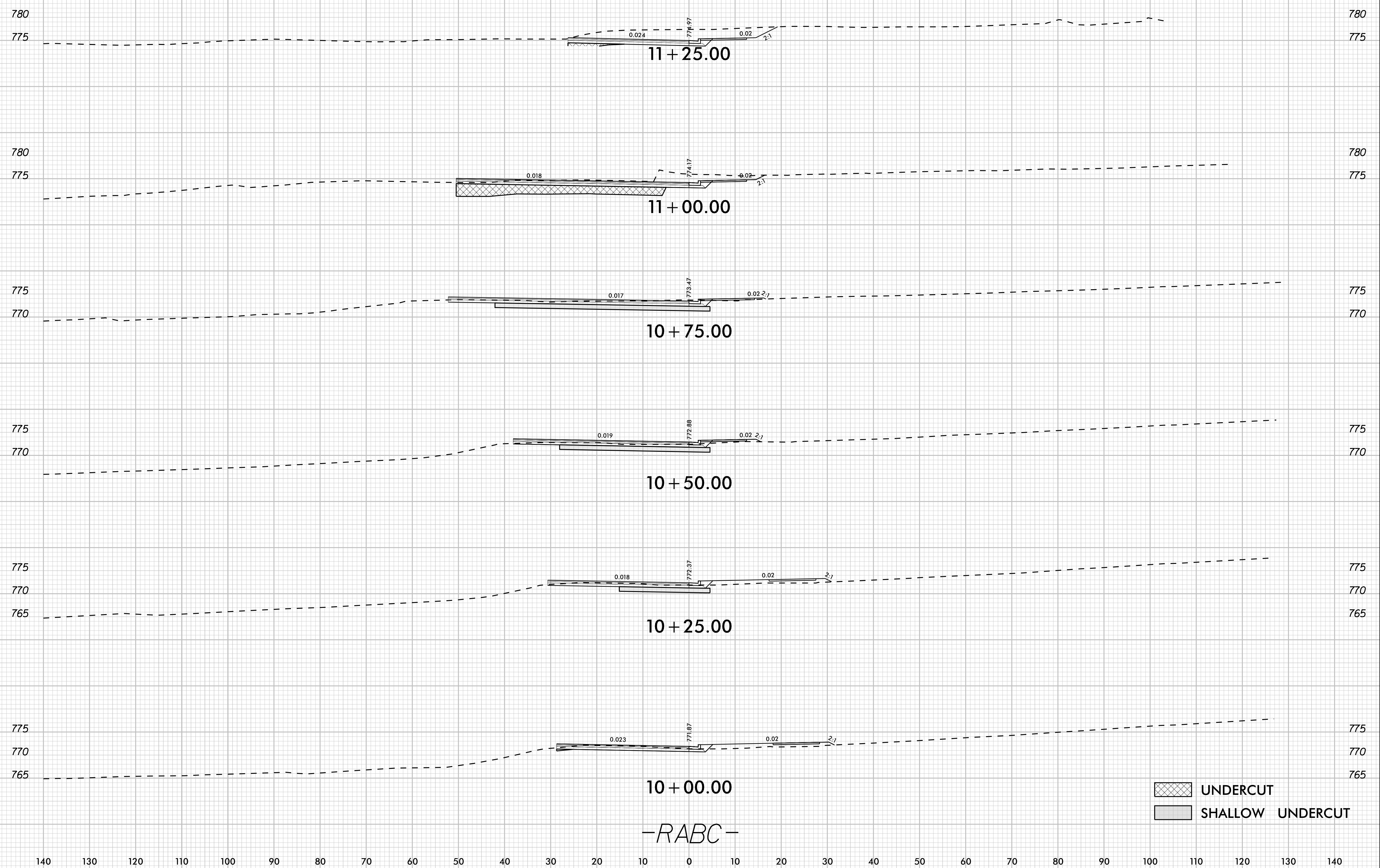

UNDERCUT
 SHALLOW UNDERCUT

K:\CHL_PRJ\01036359 - U-5108 (Northcross) DSN\Roadway\XSCU-5108_roy_xpl_RABC.dgn
 3/12/2024

-RABC-

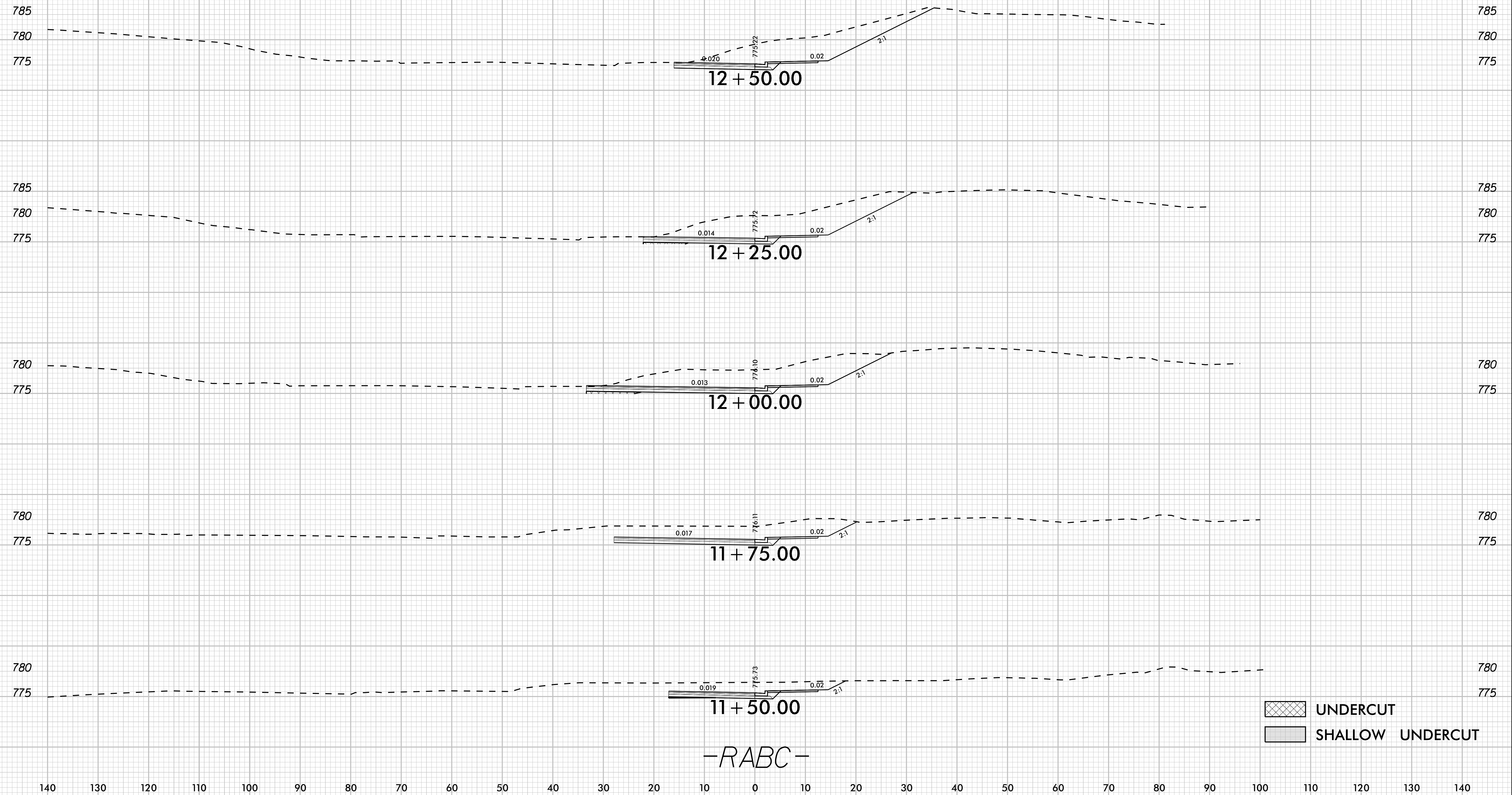

K:\CHL_P\01036359 - U-5108 (Northcross) DSN\Roadway\XSCU-5108_rdy_xpl_RABC.dgn
 3/12/2024

-RABC-

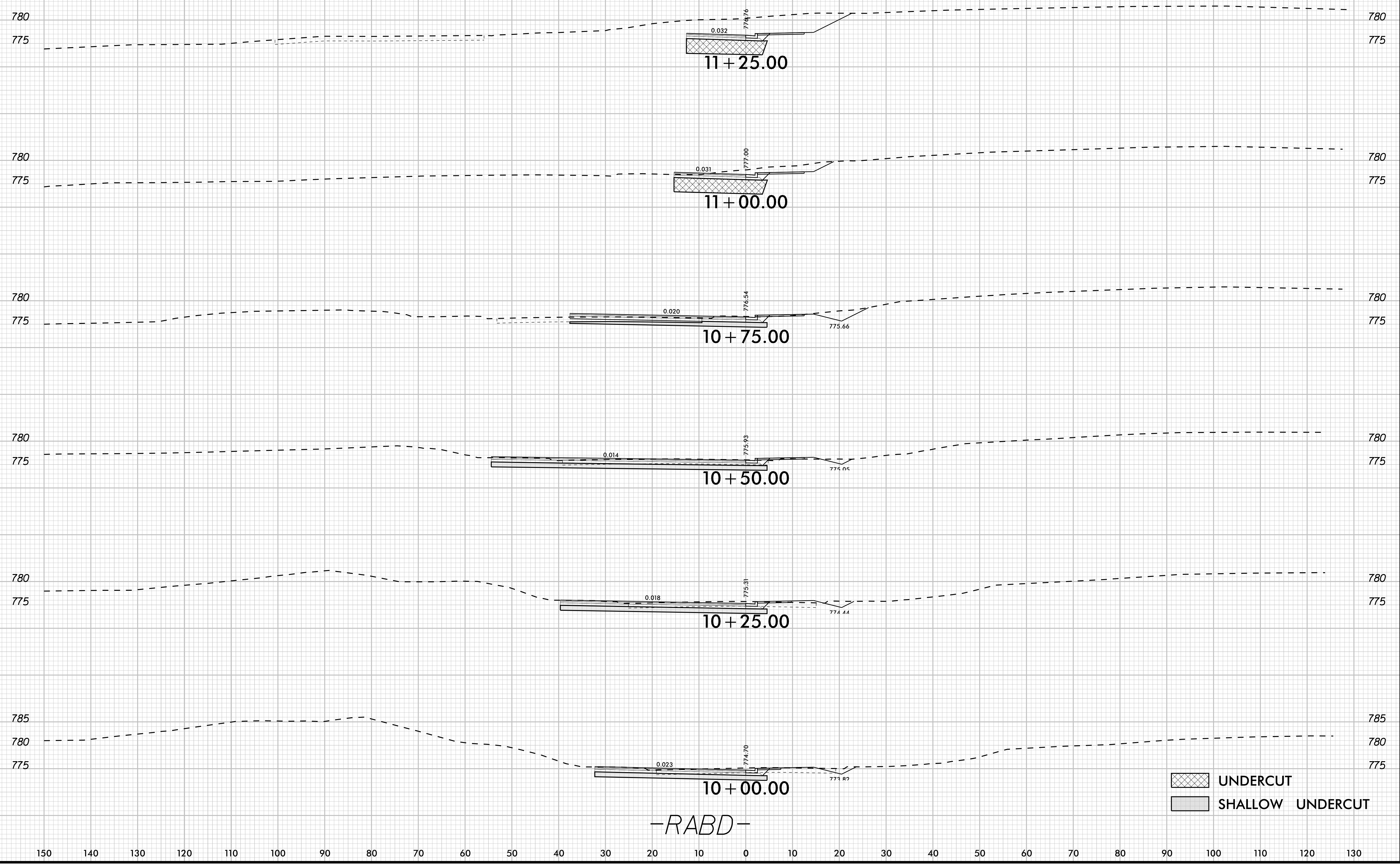

3/12/2024 K:\CHL_PROJ\01036359 - U-5108 (Northcross) DSN\Roadway\XSCU-5108_rdy_xpl_RABD.dgn

-RABD-

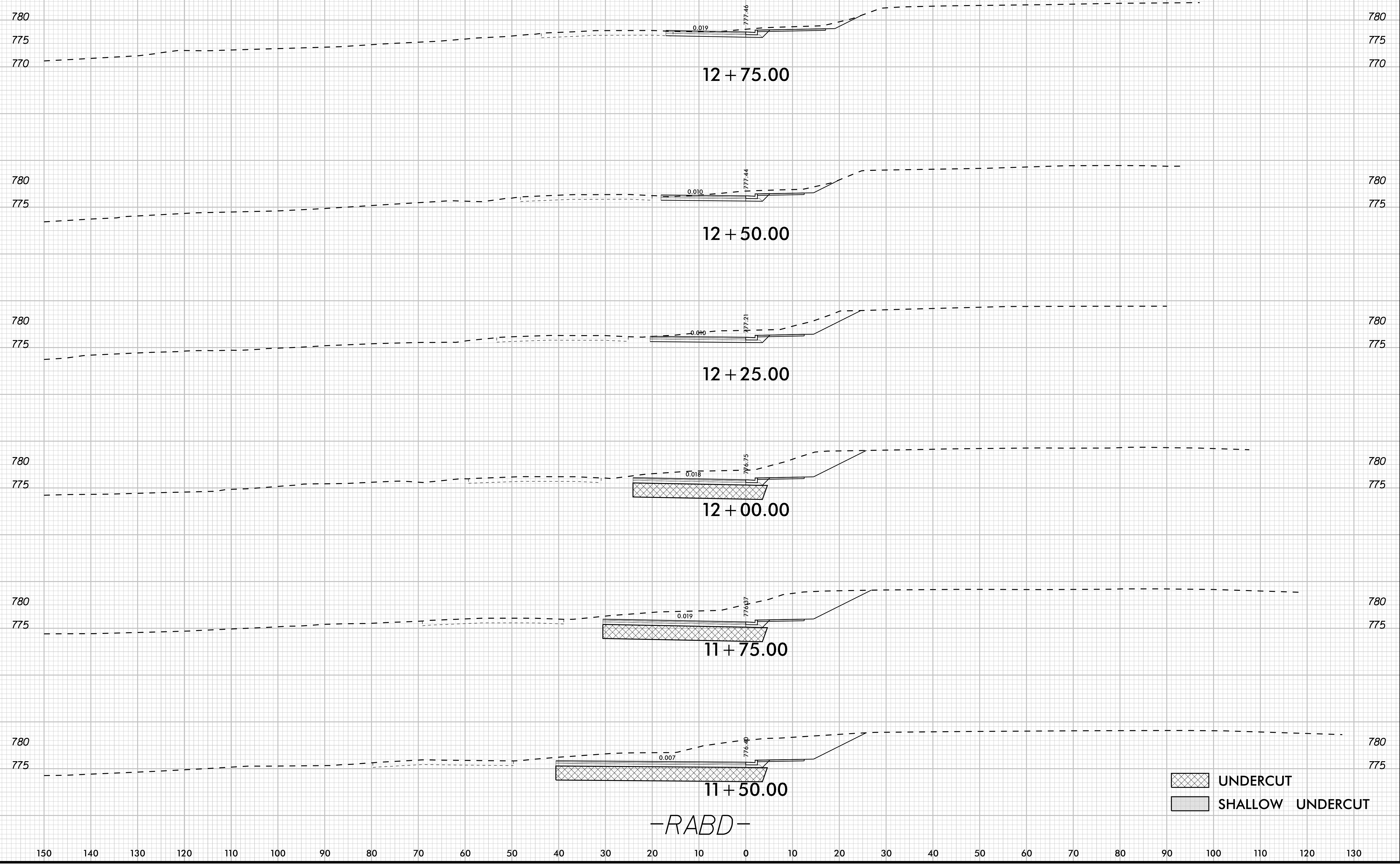

UNDERCUT
 SHALLOW UNDERCUT

-RABD-

K:\CHL_PRJ\01036359 - U-5108 (Northcross)\DSM\Roadway\XSCU-5108_roy_xp_RABD.dgn
 3/12/2024

K:\CHL_PROJ\01036359 - U-5108 (Northcross) DSN\Roadway\XSCU-5108_roy_xp_RABD.dgn
 3/12/2024



13 + 00.00
 -RABD-

UNDERCUT
 SHALLOW UNDERCUT

K:\CHL_PRJ\01036359 - U-5108 (Northcross) DSN\Roadway\XSCU-5108_roy_xpl_Y4.dgn
 4/22/2024

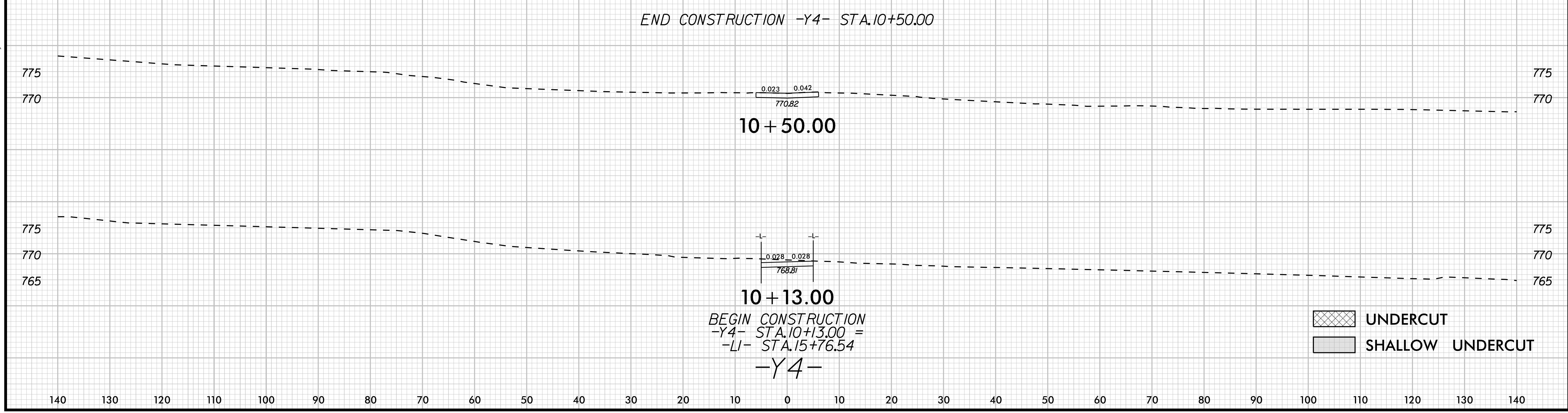

K:\CHL_PRJ\01036359 - U-5108 (Northcross) DSN\Roadway\XSCU-5108_roy_xp_1_5.dgn
 4/22/2024

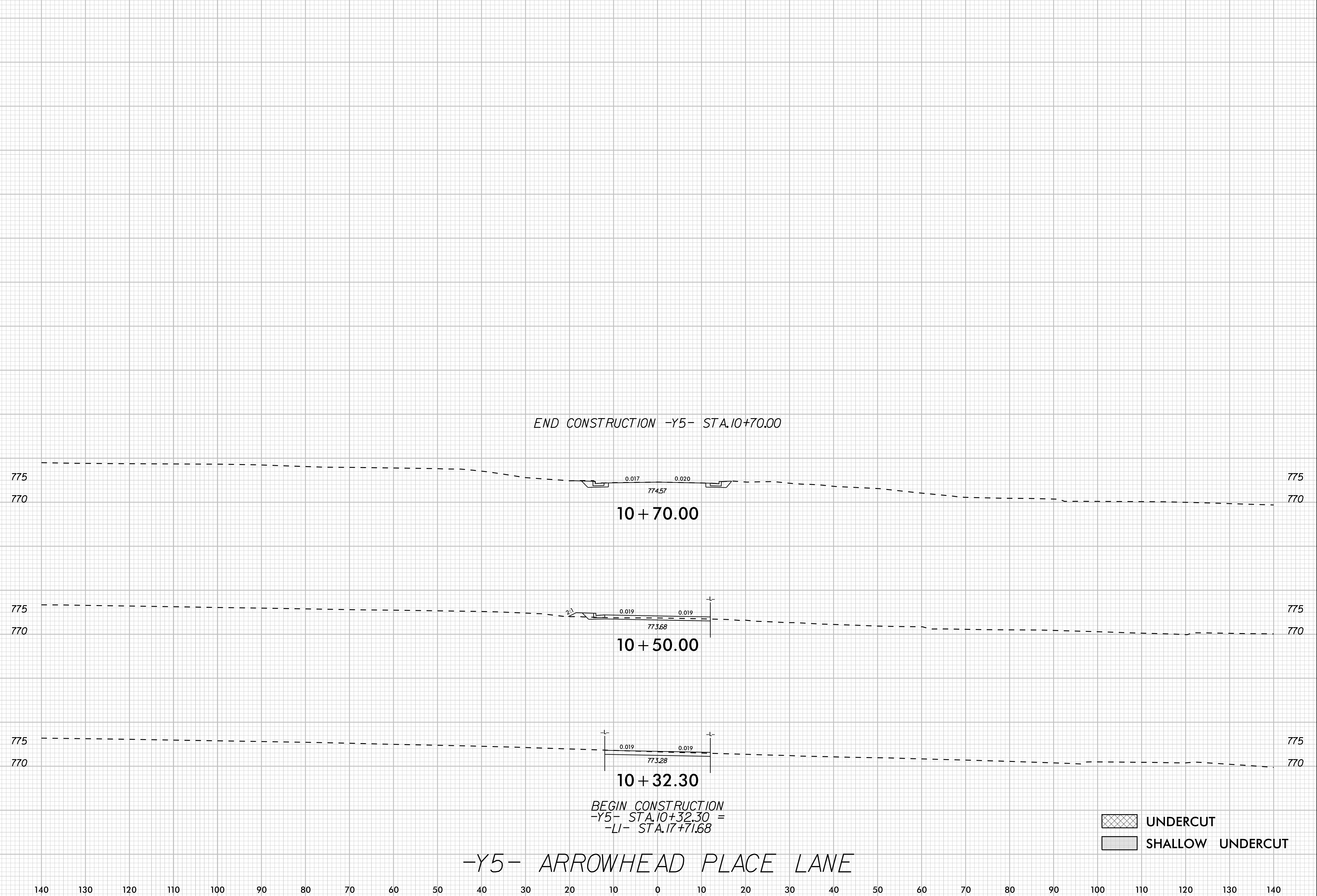

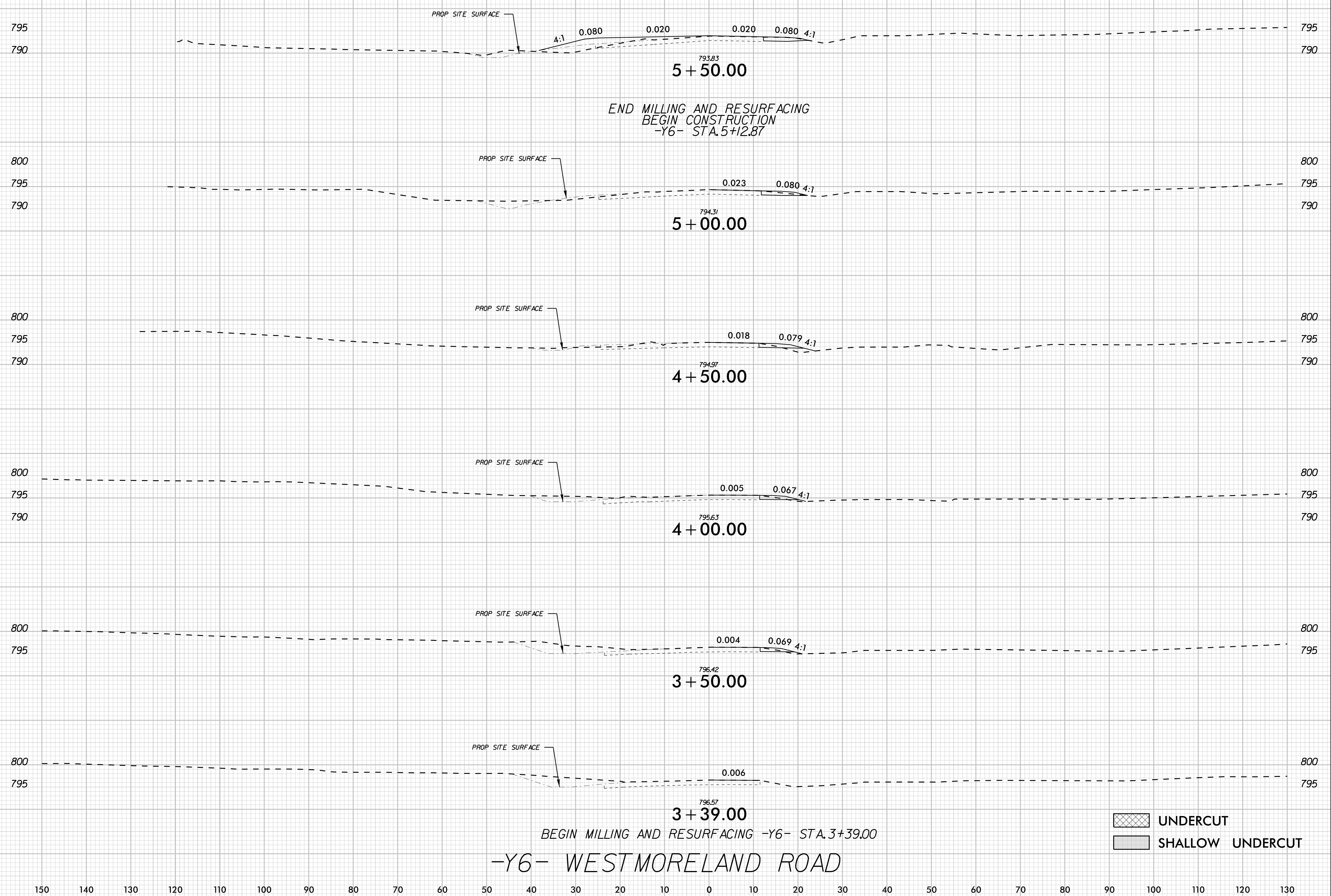

END MILLING AND RESURFACING
 BEGIN CONSTRUCTION
 -Y6- STA. 5+12.87

BEGIN MILLING AND RESURFACING -Y6- STA. 3+39.00

-Y6- WESTMORELAND ROAD

UNDERCUT
 SHALLOW UNDERCUT

K:\CHL_PROJ\01036359 - U-5108 (Northcross) DSN\Roadway\XSCU-5108_roy_xp_Y6.dgn 3/12/2024

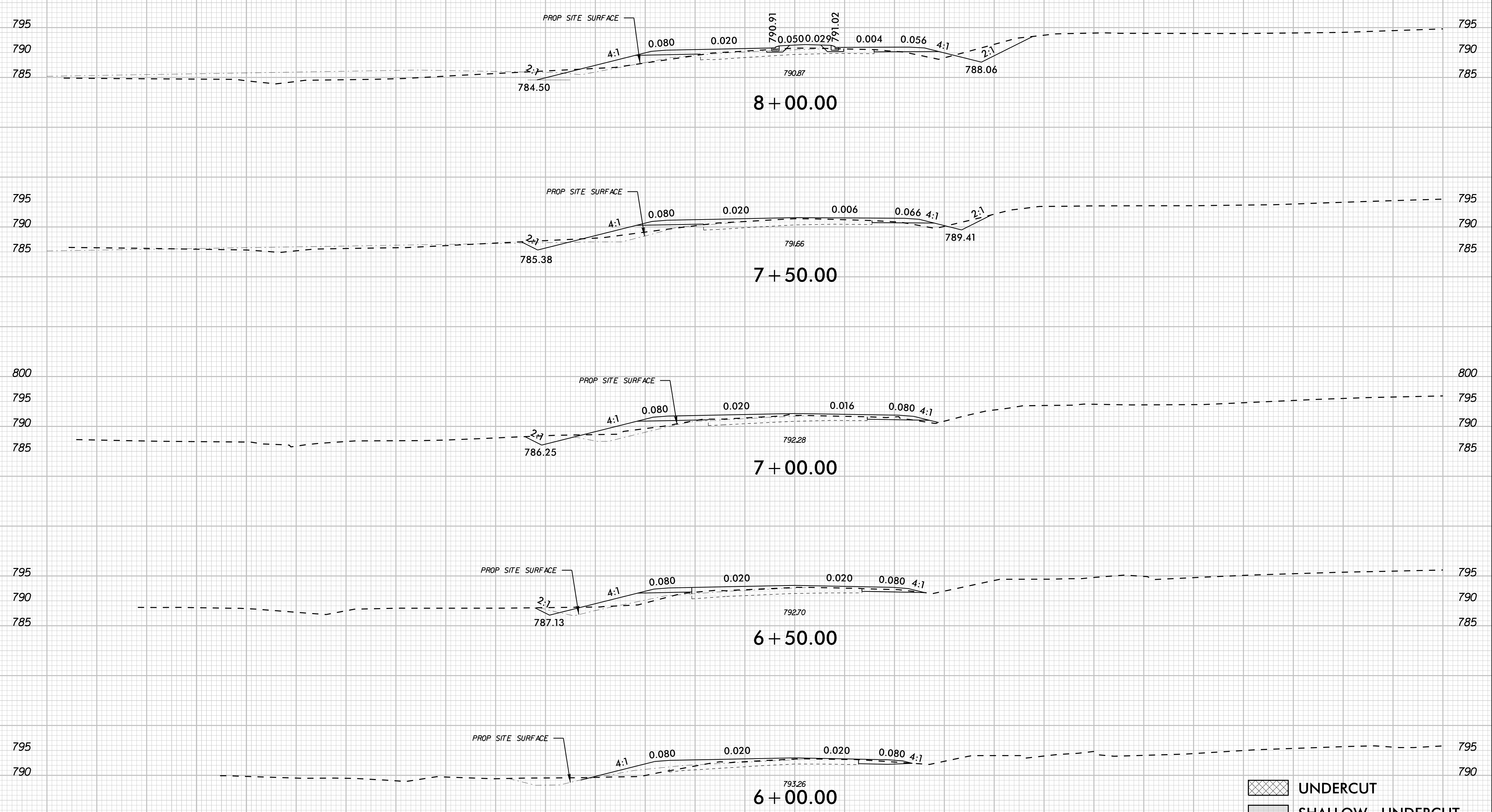

UNDERCUT
 SHALLOW UNDERCUT

-Y6- WESTMORELAND ROAD

3/12/2024 K:\CHL_P\0101036359 - U-5108 (Northcross) DSN\Roadway\XSCU-5108_roy_xp_Y6.dgn

150 140 130 120 110 100 90 80 70 60 50 40 30 20 10 0 10 20 30 40 50 60 70 80 90 100 110 120 130

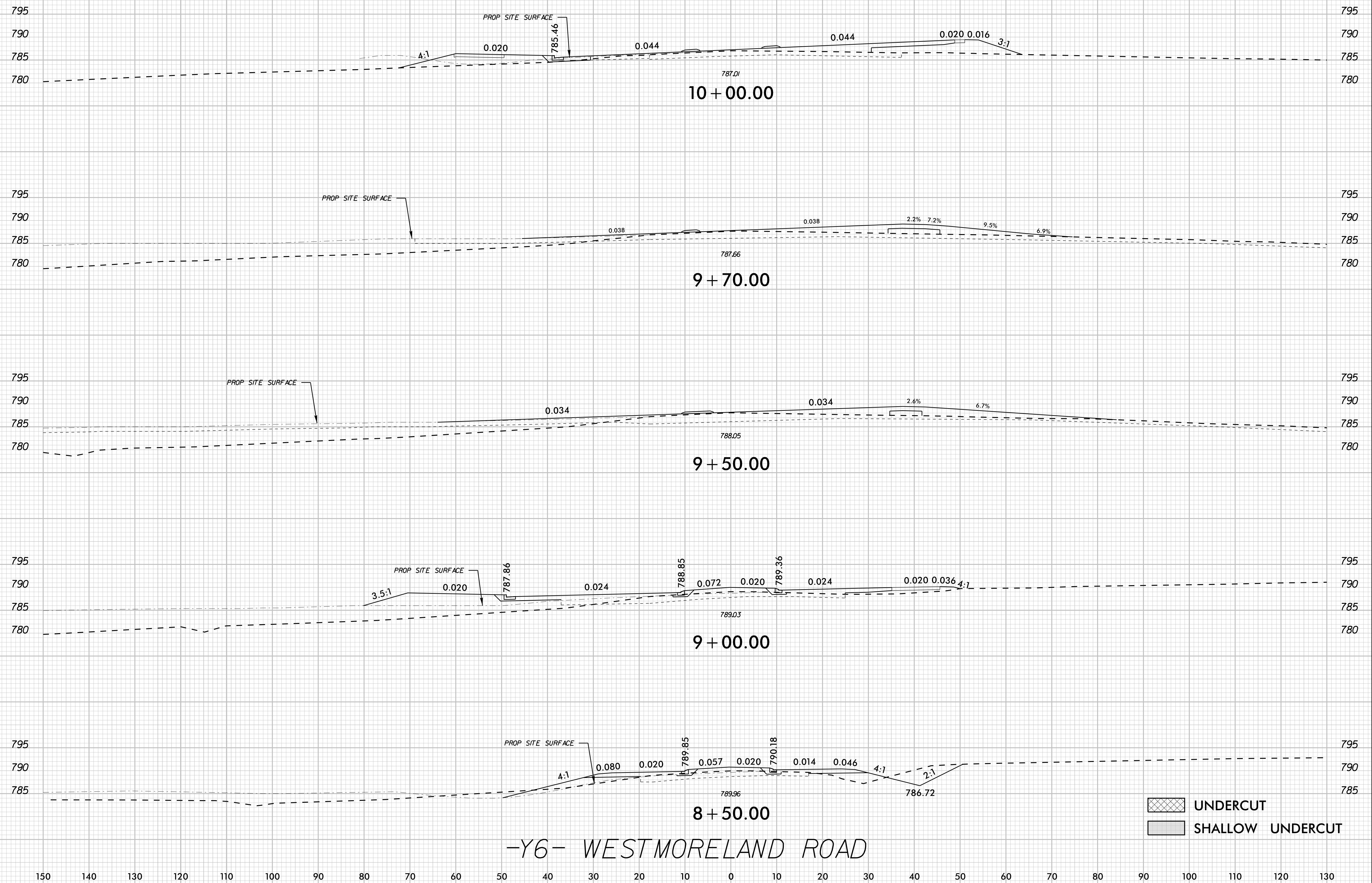

UNDERCUT
 SHALLOW UNDERCUT

-Y6- WESTMORELAND ROAD

K:\CHL_P\0101036359 - U-5108 (Northcross) DSN\Roadway\XSCU-5108_roy_xp_Y6.dgn 3/12/2024

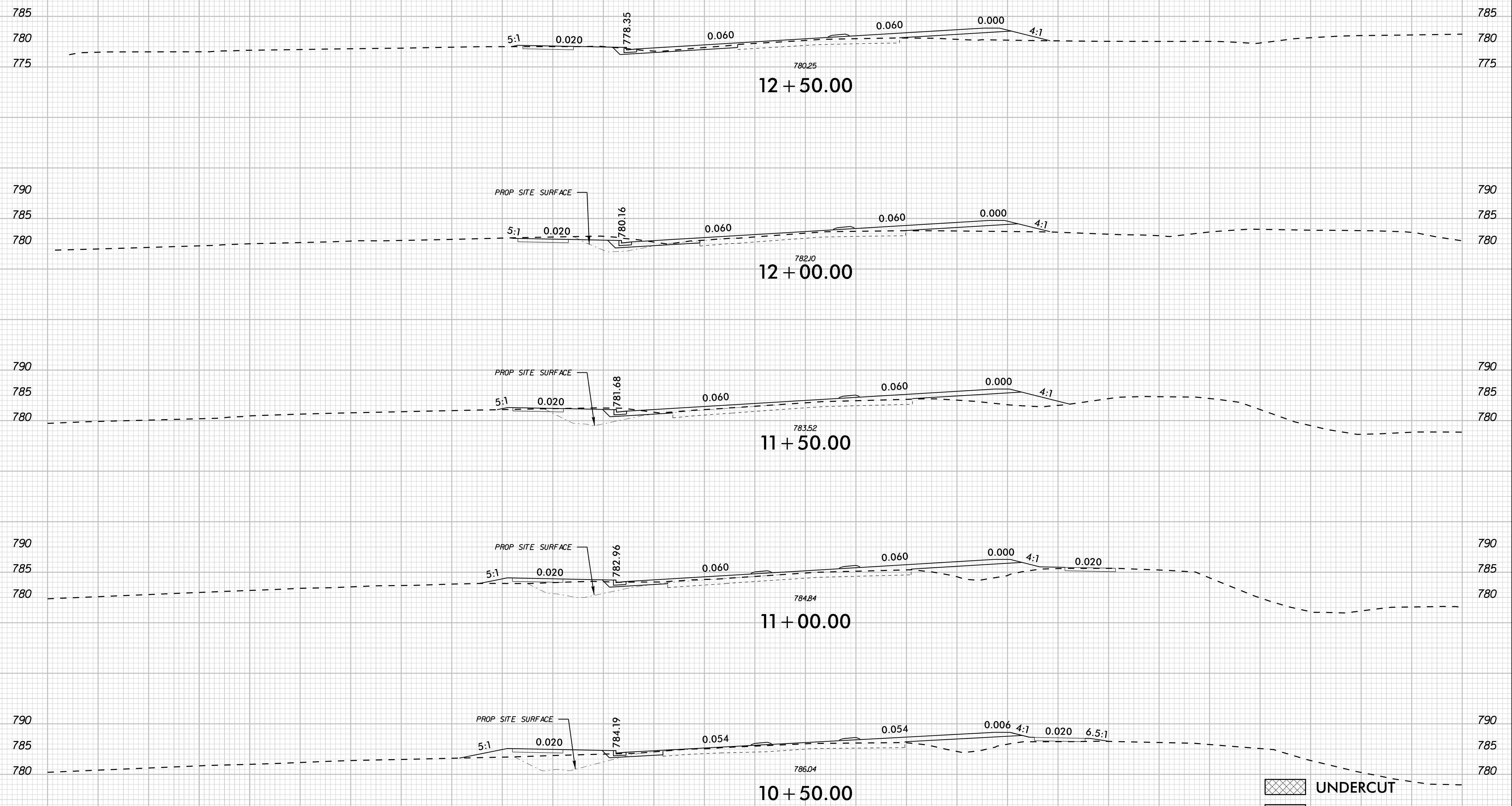

UNDERCUT
 SHALLOW UNDERCUT

-Y6- WESTMORELAND ROAD

3/12/2024 K:\CHL_PRJ\01036359 - U-5108 (Northcross) DSN\Roadway\XSCU-5108_roy_xpl_Y6.dgn

150 140 130 120 110 100 90 80 70 60 50 40 30 20 10 0 10 20 30 40 50 60 70 80 90 100 110 120 130

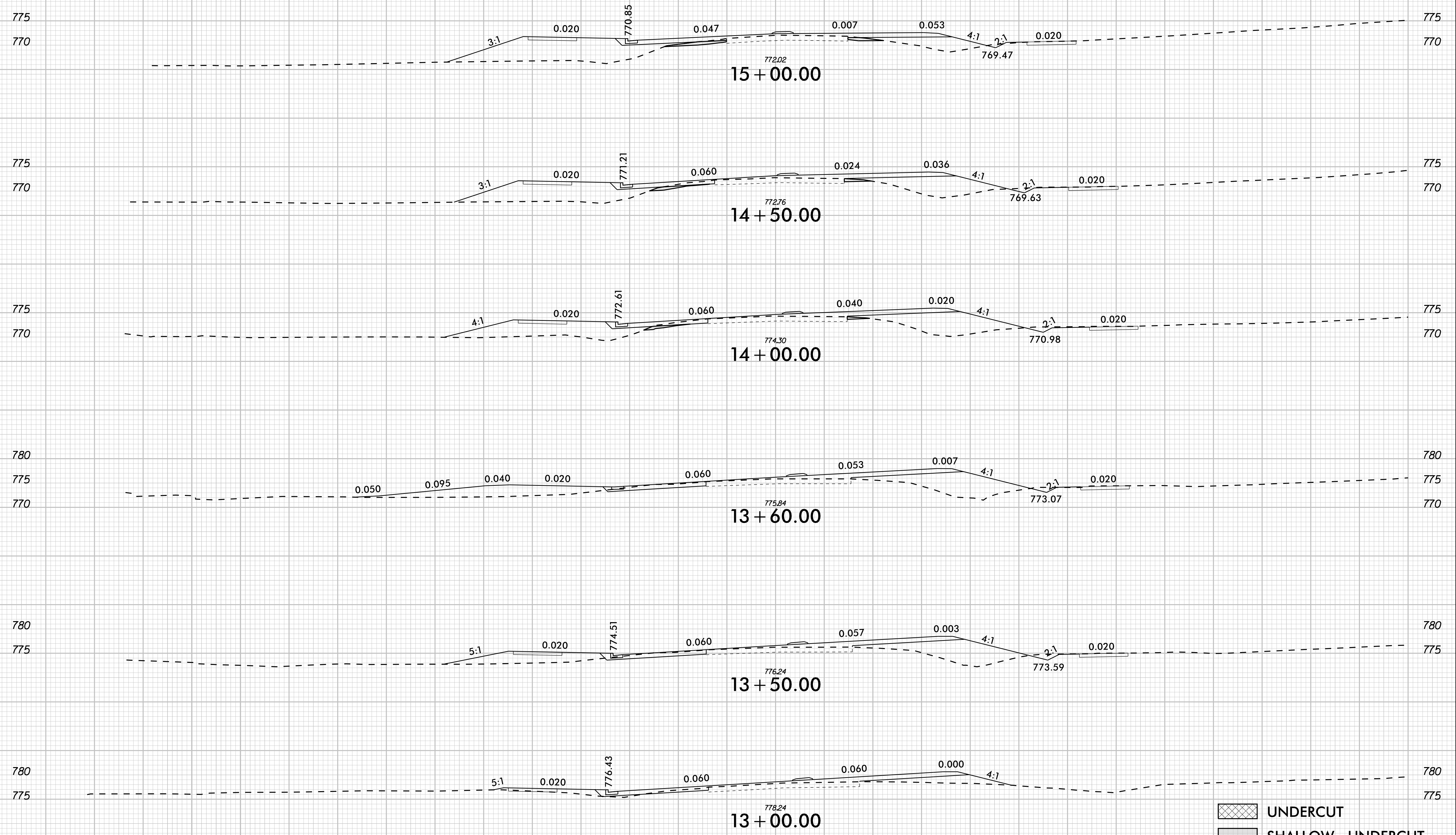

-Y6- WESTMORELAND ROAD

UNDERCUT
 SHALLOW UNDERCUT

K:\CHL_PRJ\01036359 - U-5108 (Northcross) DSM\Roadway\XSCU-5108_rdy_xpl_Y6.dgn 3/12/2024

150 140 130 120 110 100 90 80 70 60 50 40 30 20 10 0 10 20 30 40 50 60 70 80 90 100 110 120 130

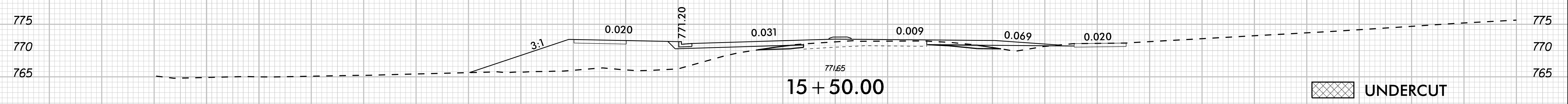
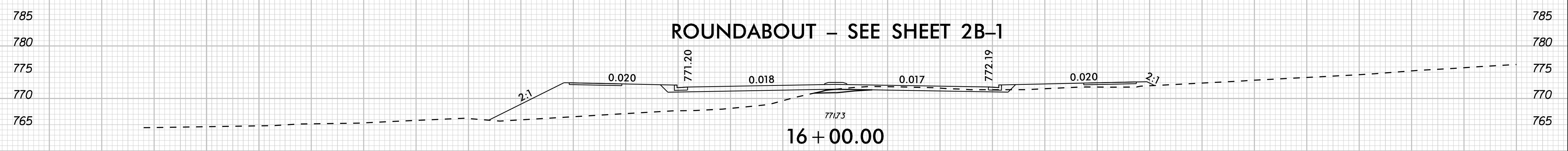
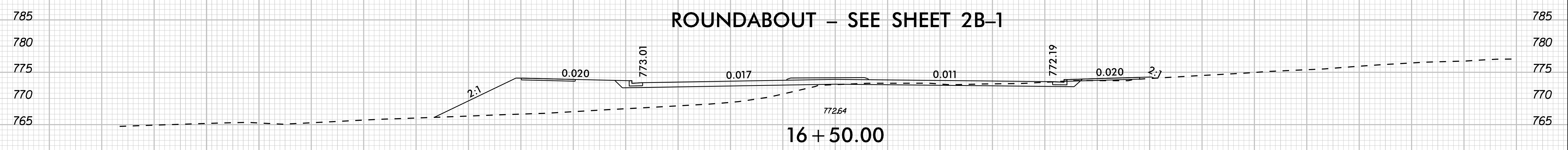
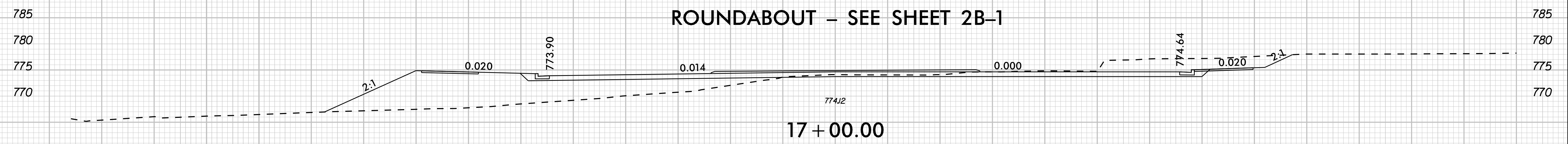

UNDERCUT
 SHALLOW UNDERCUT

-Y6- WESTMORELAND ROAD

K:\CHL_PRJ\01036359 - U-5108 (Northcross) DSN\Roadway\XSCU-5108_roy_xp_Y6.dgn
 3/12/2024

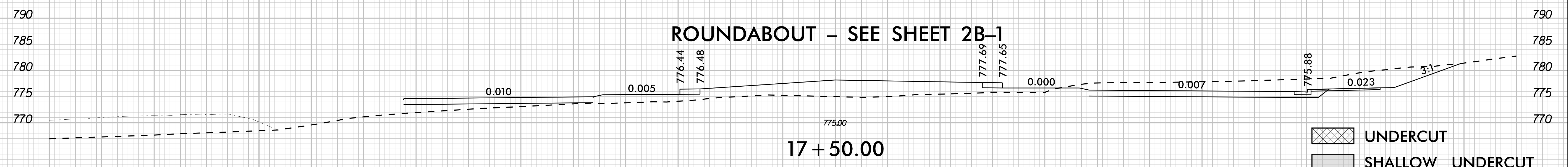
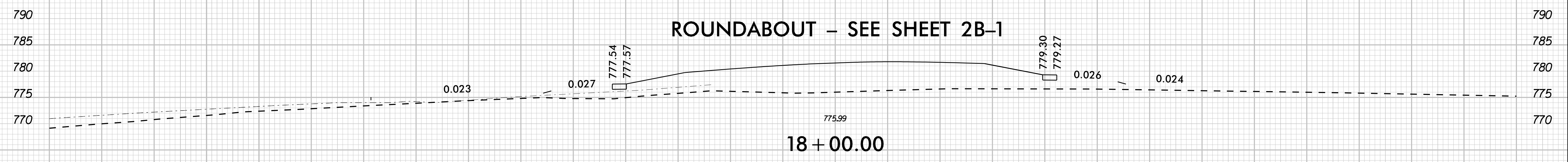
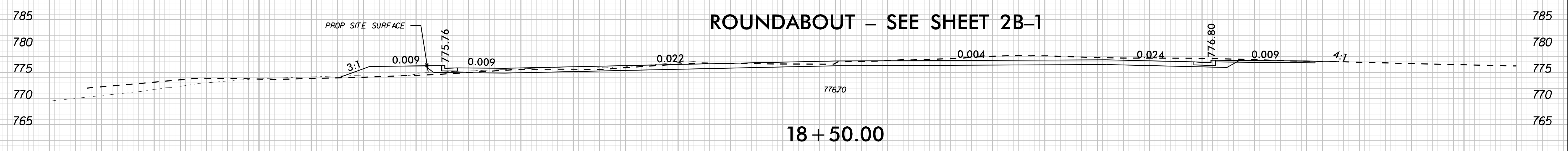
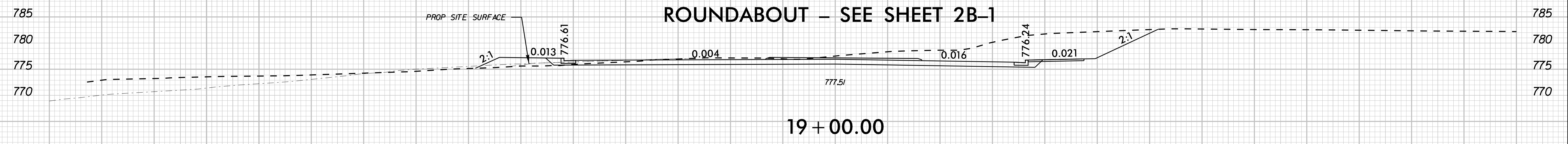

-Y6- WESTMORELAND ROAD

UNDERCUT
 SHALLOW UNDERCUT

K:\CHL_PRJ\01036359 - U-5108 (Northcross) DSM\Roadway\XSCU-5108_roy_xpl_Y6.dgn 3/12/2024

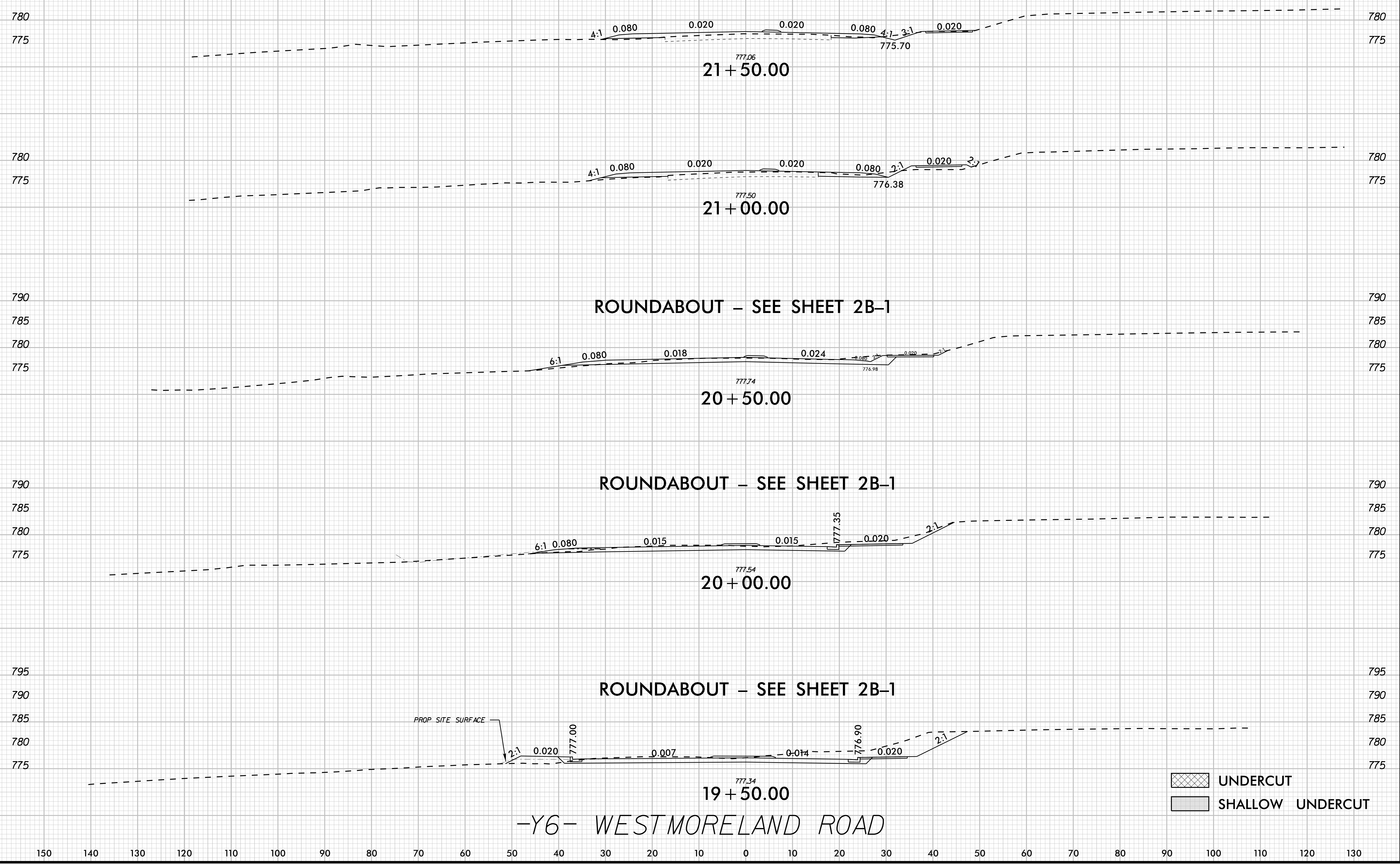

K:\CHL_PRJ\01036359 - U-5108 (Northcross) DSN\Roadway\XSCU-5108_roy_xp_1_Y6.dgn
 3/12/2024

-Y6- WESTMORELAND ROAD

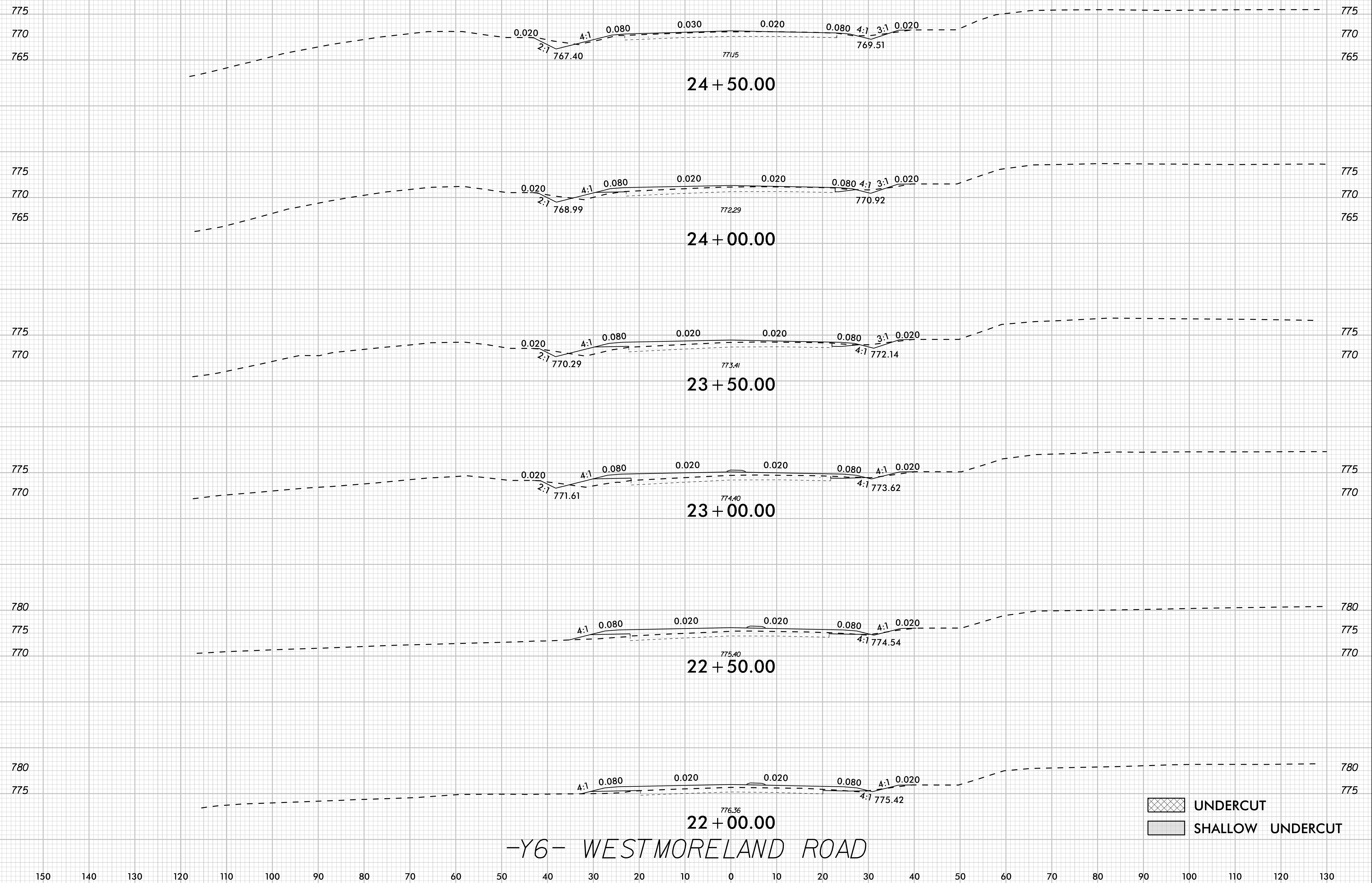

UNDERCUT
 SHALLOW UNDERCUT

-Y6- WESTMORELAND ROAD

3/12/2024 K:\CHL_PRJ\01036359 - U-5108 (Northcross) DSN\Roadway\XSCU-5108_ry_xp_Y6.dgn

K:\CHL_PROJ\01036359 - U-5108 (Northcross) DSM\Roadway\XSCU-5108_ry_xp_Y6.dgn
 3/12/2024

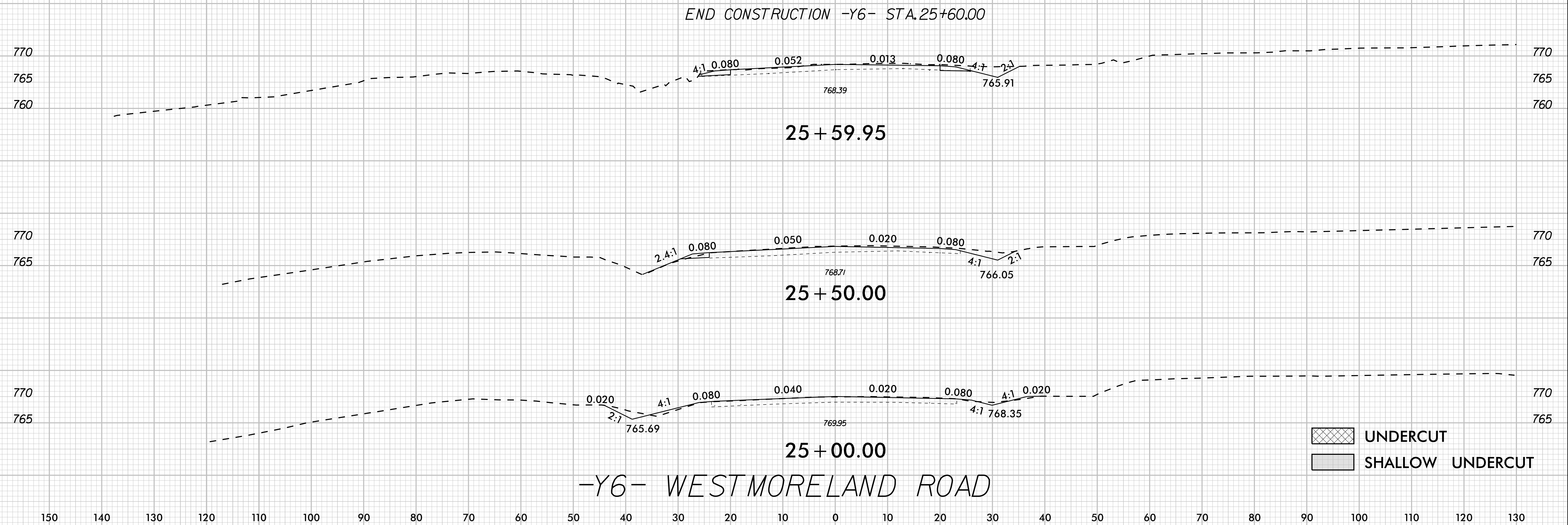

END CONSTRUCTION -Y7- STA.10+85.00

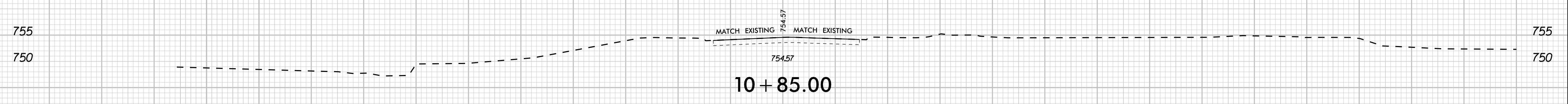

10 + 85.00

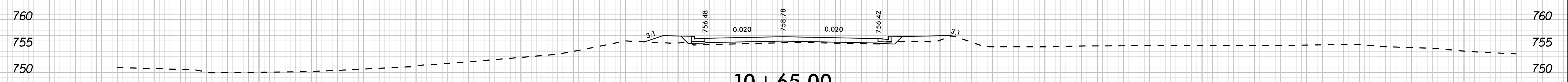

10 + 65.00

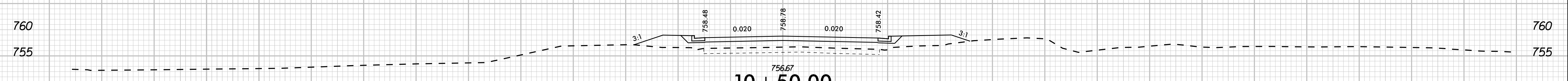

10 + 50.00

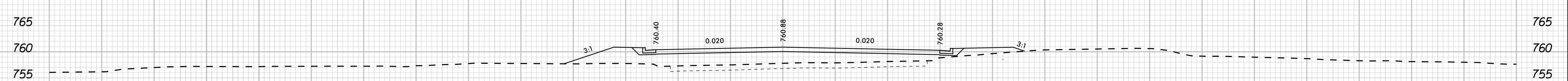

10 + 25.00

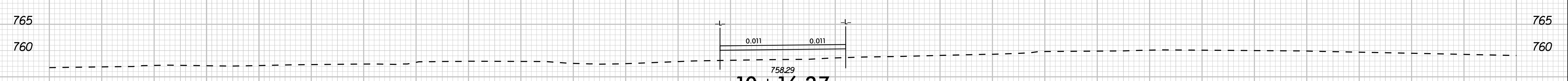

10 + 16.27

BEGIN CONSTRUCTION -Y7- STA.10+00.00

-Y7- FOREST SHADOW CIRCLE

UNDERCUT
 SHALLOW UNDERCUT

K:\CHL_PROJ\01036359 - U-5108 (Northcross) DSN\Roadway\XSCU-5108_roy_xp_17.dgn 3/12/2024

140 130 120 110 100 90 80 70 60 50 40 30 20 10 0 10 20 30 40 50 60 70 80 90 100 110 120 130 140

END CONSTRUCTION -Y8- STA.11+72.11

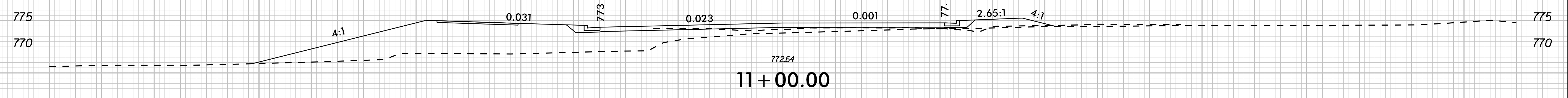
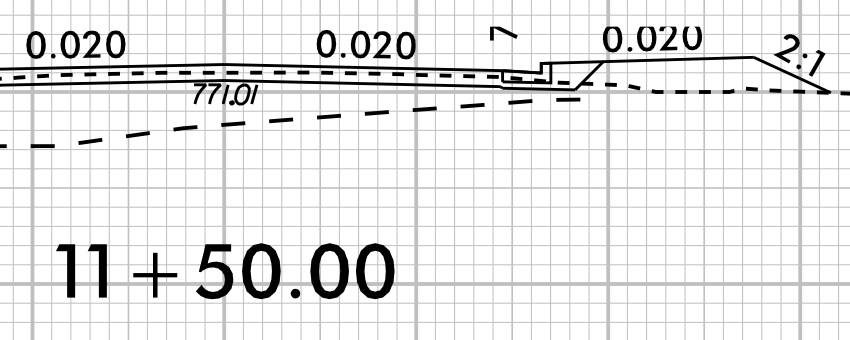
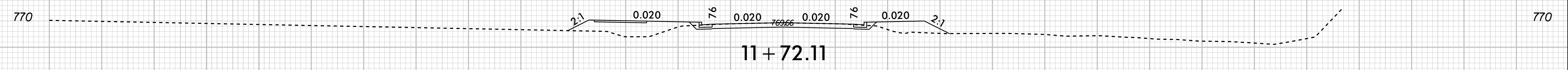

ROUNDABOUT - SEE SHEET 2B-1

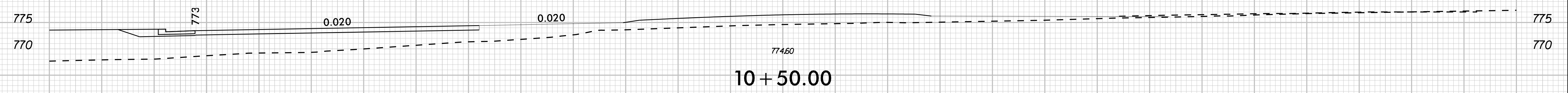

ROUNDABOUT - SEE SHEET 2B-1

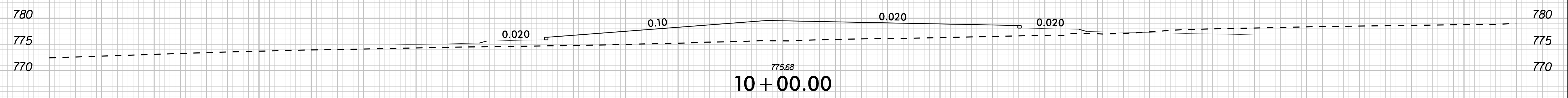

BEGIN CONSTRUCTION
 -Y8- STA.10+00.00 =
 -L1- STA.20+10.59 =
 -Y6- STA.17+83.54

UNDERCUT
 SHALLOW UNDERCUT

K:\CHL_PRJ\01036359 - U-5108 (Northcross) DSN\Roadway\XSCU-5108_roy_xp_1B.dgn 3/12/2024

140 130 120 110 100 90 80 70 60 50 40 30 20 10 0 10 20 30 40 50 60 70 80 90 100 110 120 130 140

K:\CHL_PRJ\01036359 - U-5108 (Northcross) DSN\Roadway\XSCU-5108_roy_xpl_DRW02.dgn

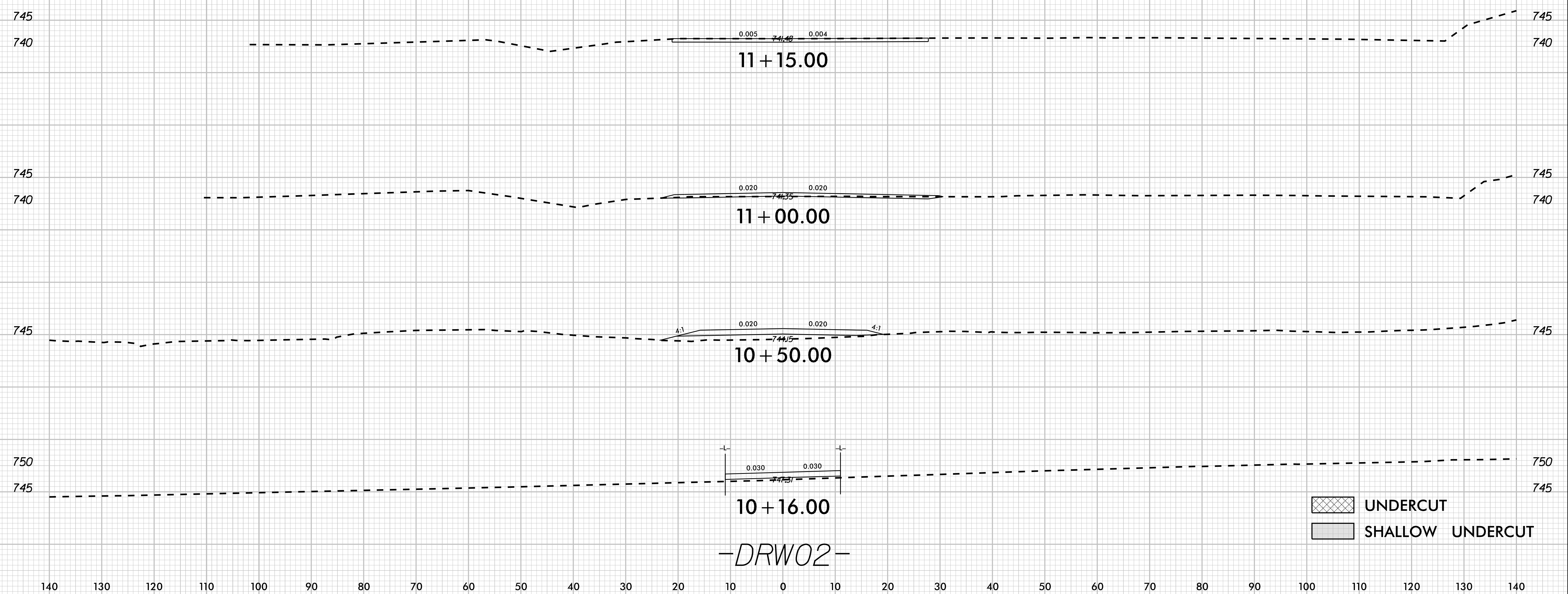

-DRW02-

K:\CHL_PROJ\01036359 - U-5108 (Northcross) DSN\Roadway\XSCU-5108_roy_xpl_DRW03.dgn
3/12/2024

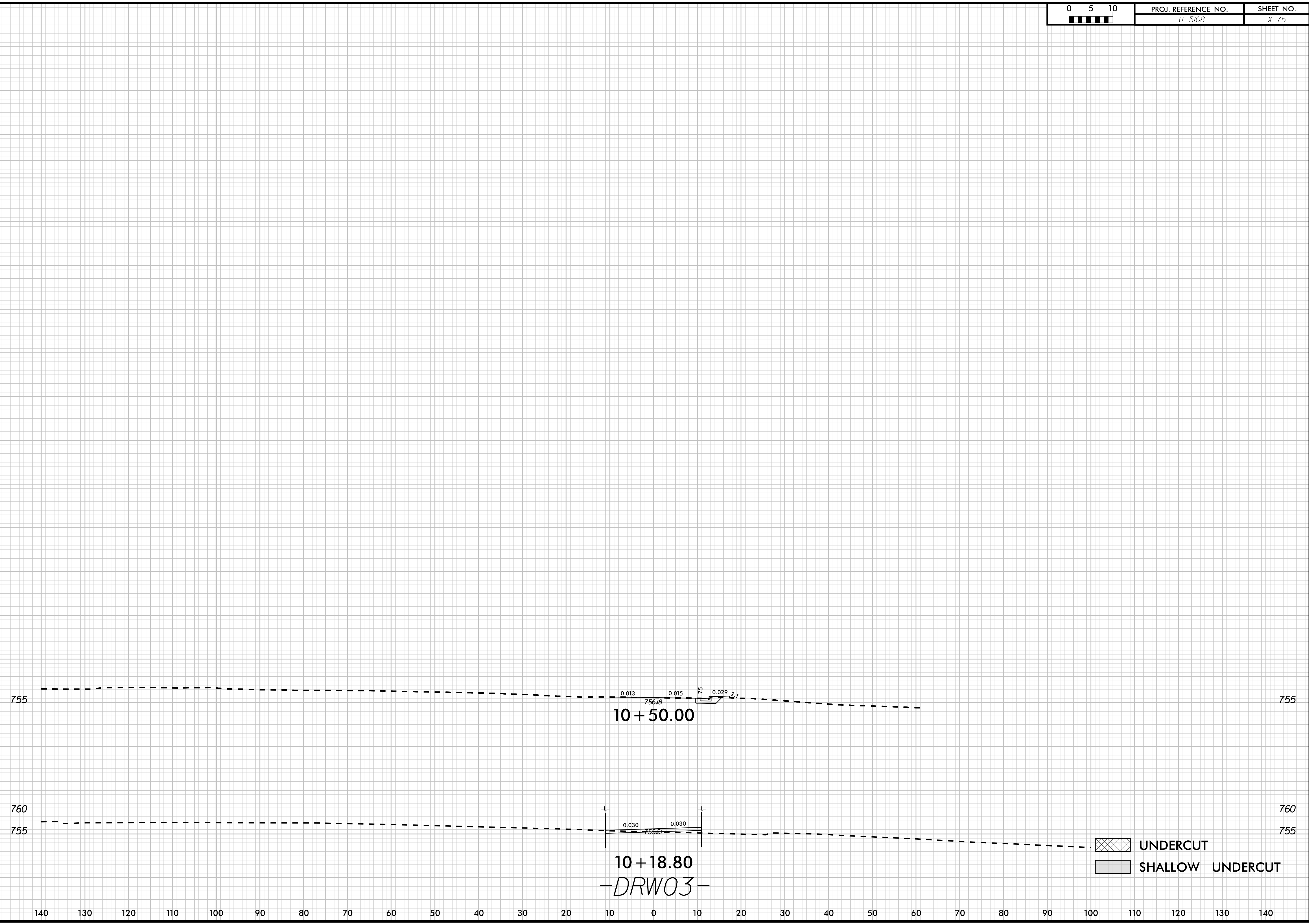

UNDERCUT
 SHALLOW UNDERCUT

10 + 50.00
10 + 18.80
-DRW03-

K:\CHL_PROJ\01036359 - U-5108 (Northcross) DSN\Roadway\XSCU-5108_roy_xpl_DRW05.dgn
3/12/2024

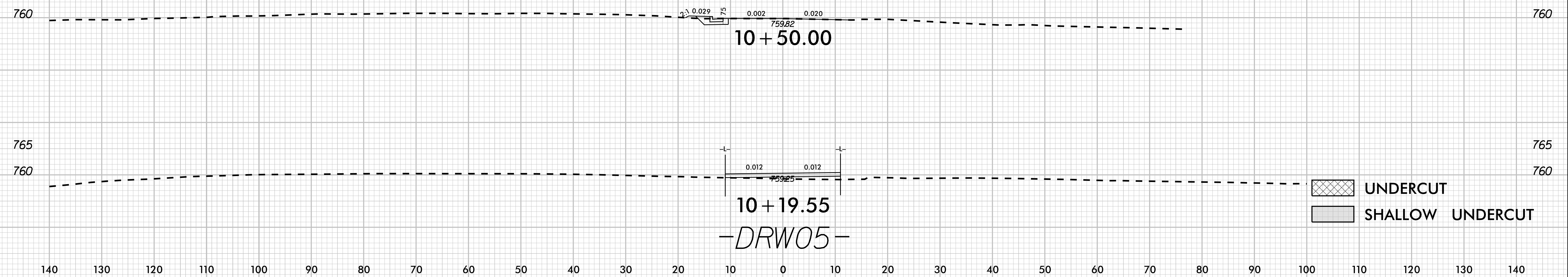

-DRW05-

K:\CHL_PROJ\01036359 - U-5108 (Northcross) DSM\Roadway\XSCU-5108_roy_xp_DRW\2.dgn
3/12/2024

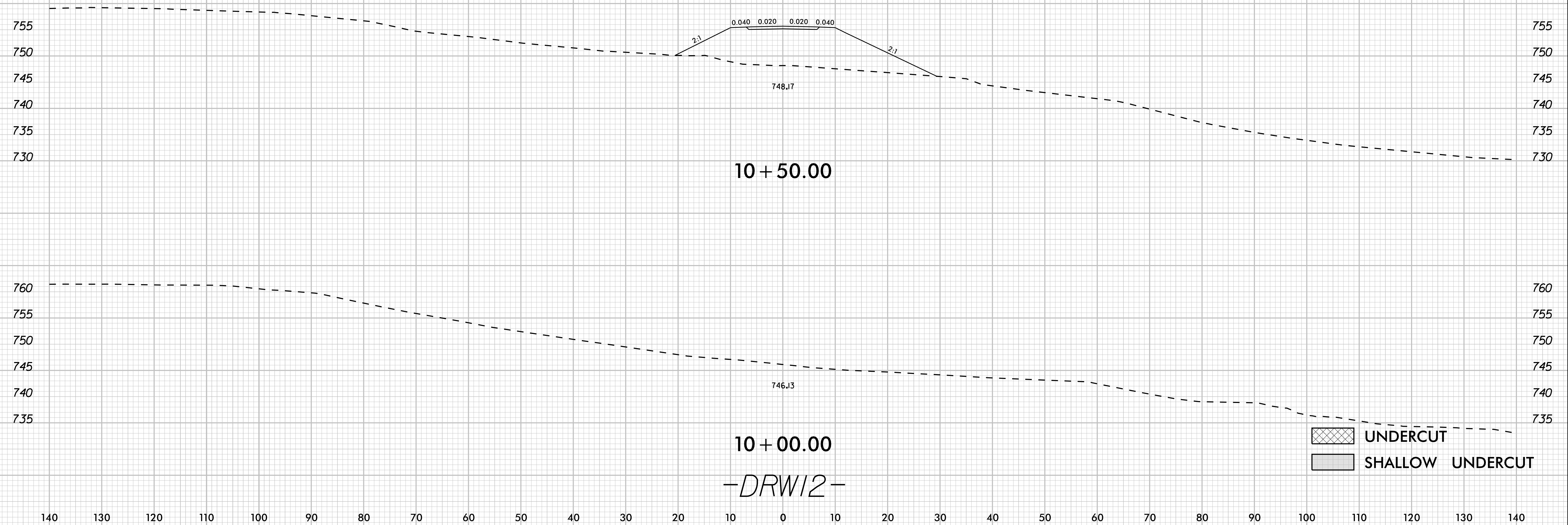

-DRW12-

UNDERCUT
 SHALLOW UNDERCUT

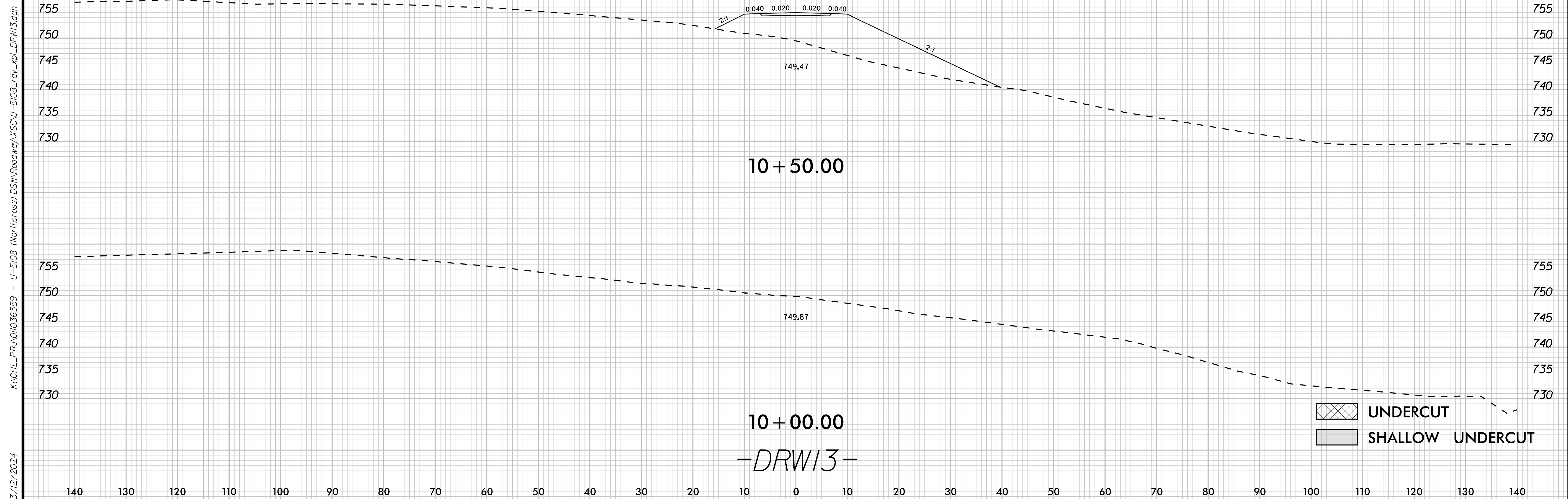

K:\CHL_PROJ\01036359 - U-5108 (Northcross) DSN\Roadway\XSCU-5108_roy_xp_DRW13.dgn
 3/12/2024

-DRW13-

K:\CHL_PRJ\01036359 - U-5108 (Northcross) DSN\Roadway\XSCU-5108_roy_xpl_DRW15.dgn
 3/12/2024

