

NOTES

STIRRUPS IN CAP MAY BE SHIFTED AS NECESSARY TO CLEAR DOWELS.  
 THE CONCRETE IN THE SHADED AREA OF THE WING SHALL BE POURED AFTER THE PARAPET IS CAST IF SLIP FORMING IS USED.  
 FOR PILE SPLICE DETAILS, SEE SHEET 4 OF 4.  
 FOR WING DETAILS, SEE SHEET 3 OF 4.

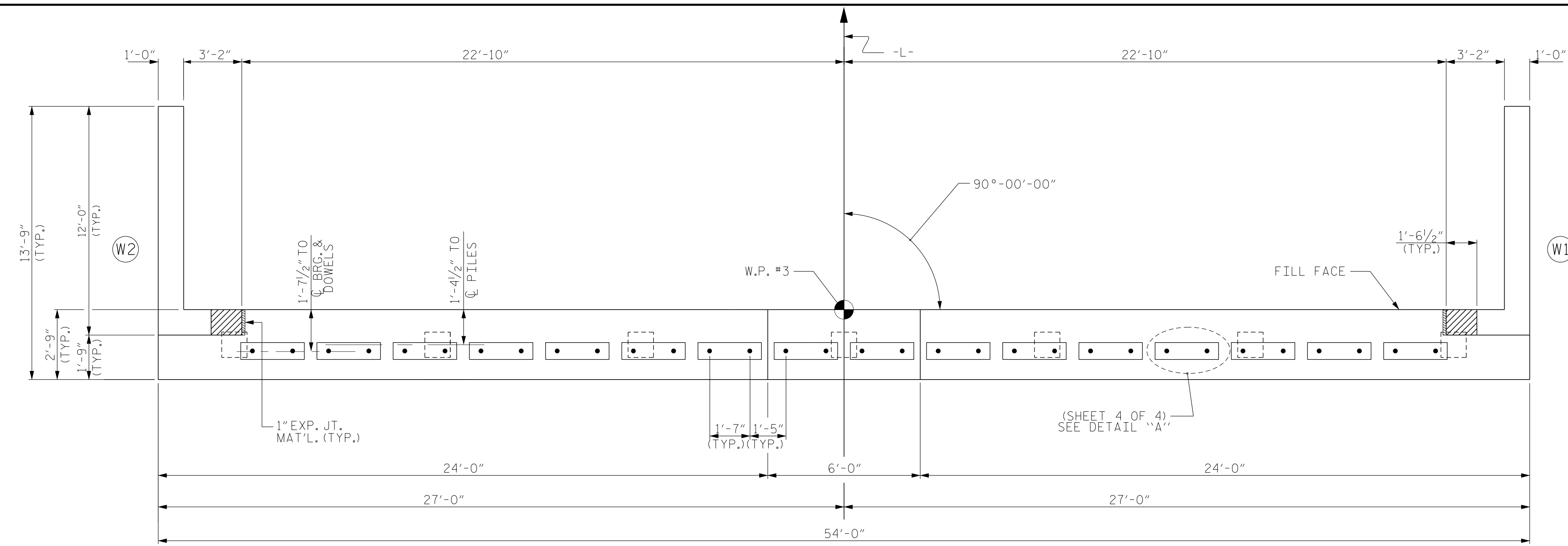

PLAN

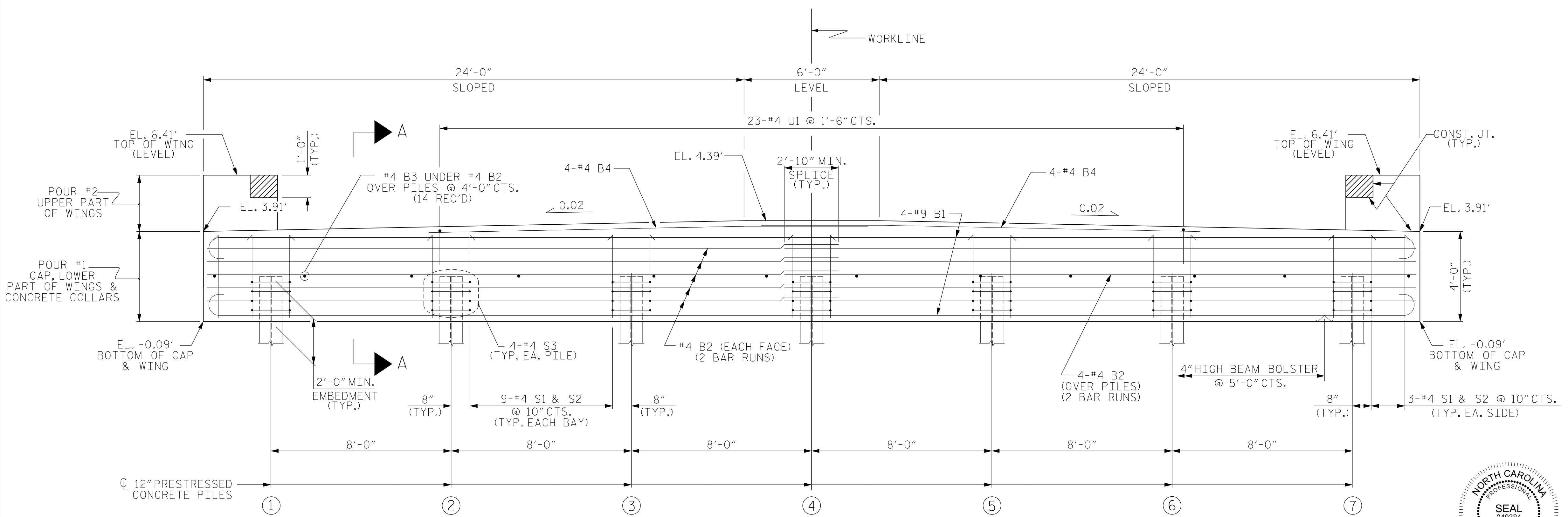

ELEVATION

WINGS NOT SHOWN FOR CLARITY. FOR SECTION A-A, SEE SHEET 4 OF 4.

PROJECT NO. B-5610  
 DARE COUNTY  
 STATION: 15+42.50 -L-

SHEET 2 OF 4

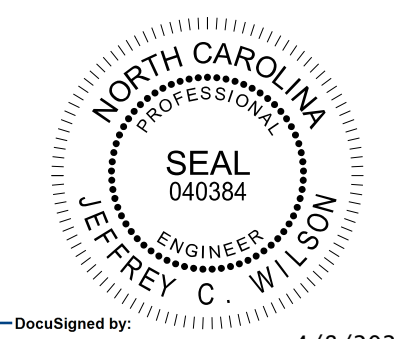

DocuSigned by:  
 Jeffrey C. Wilson  
 84430599F4642A  
 4/8/2024  
 DOCUMENT NOT CONSIDERED FINAL UNLESS ALL SIGNATURES COMPLETED

**STEWART**  
 Firm License No. C-1051  
 223 S West St,  
 Suite 1100  
 Raleigh, NC 27603  
 T 919.380.8750  
 www.stewartinc.com

STATE OF NORTH CAROLINA DEPARTMENT OF TRANSPORTATION RALEIGH					
SUBSTRUCTURE					
END BENT 2					
REVISIONS					
NO.	BY:	DATE:	NO.	BY:	DATE:
1			3		
2			4		
SHEET NO.					S-20
TOTAL SHEETS					29

DRAWN BY: G. RAMBOULI DATE: 1/24  
 CHECKED BY: J. WILSON DATE: 1/24  
 DESIGN ENGINEER OF RECORD: J. WILSON DATE: 1/24

B-5610  
 4/4/2024  
 B-5610-SMUJ-E2-270008.dgn  
 USER: jwilson