

- ② TEMP SHORING -L- STA. 33+85 OFF 23' L TO -L- STA. 34+05 OFF 23' L 8' DEEP
AVERAGE HEIGHT: 8', QUANTITY = 160 SF
- ③ TEMP SHORING -L- STA. 36+00 OFF 23' L TO -L- STA. 36+15 OFF 23' L 8' DEEP
AVERAGE HEIGHT: 8', QUANTITY = 120 SF

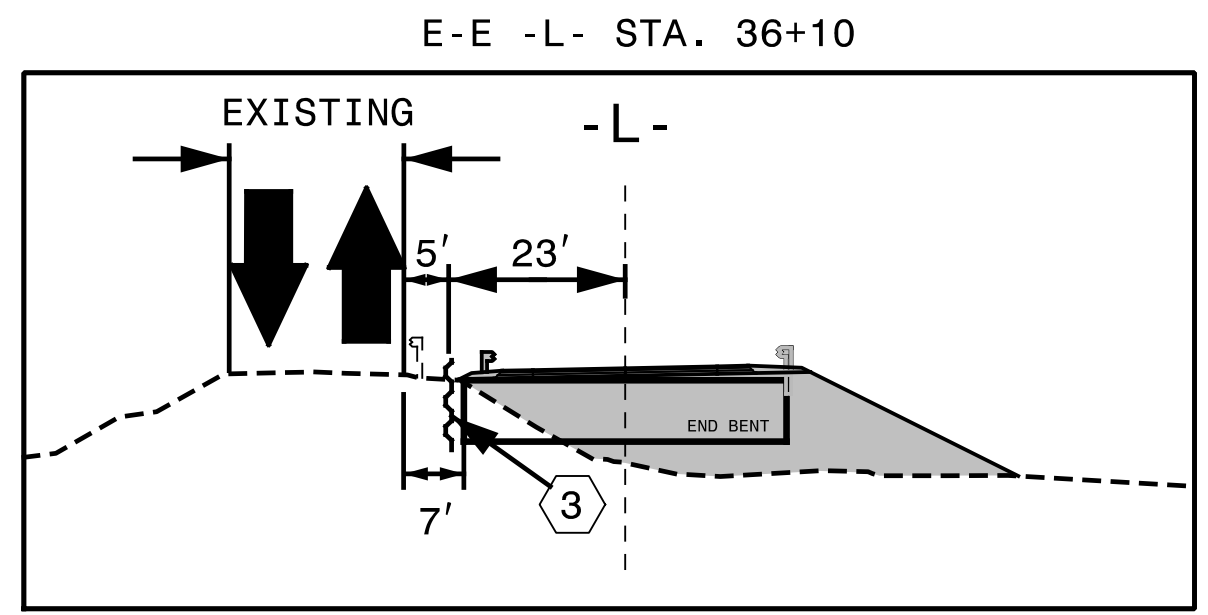
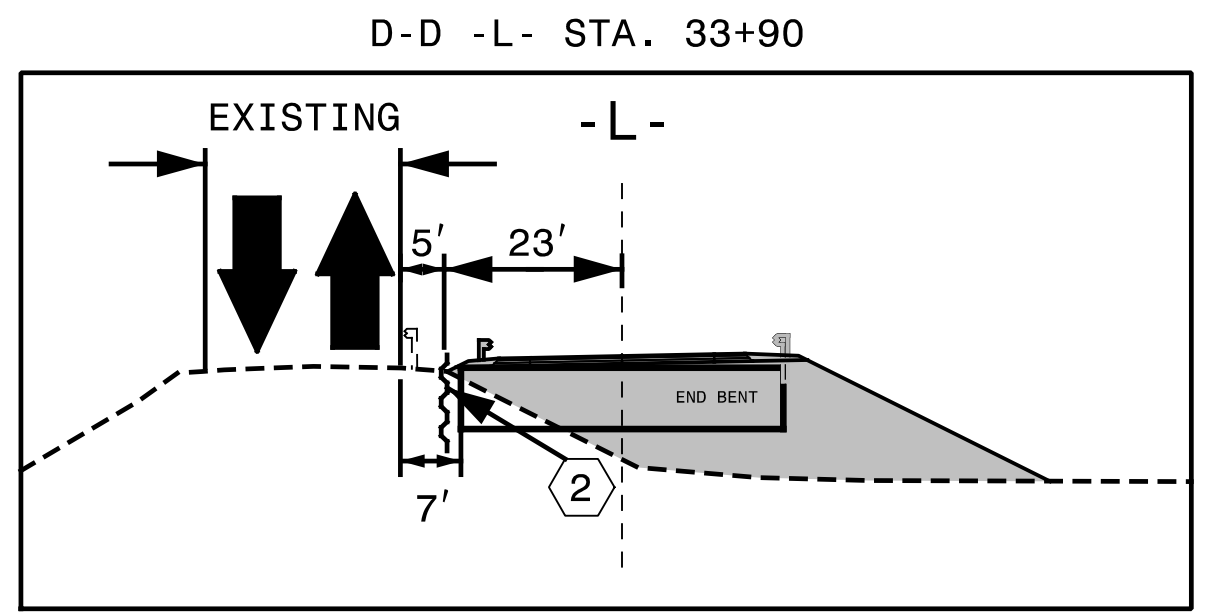
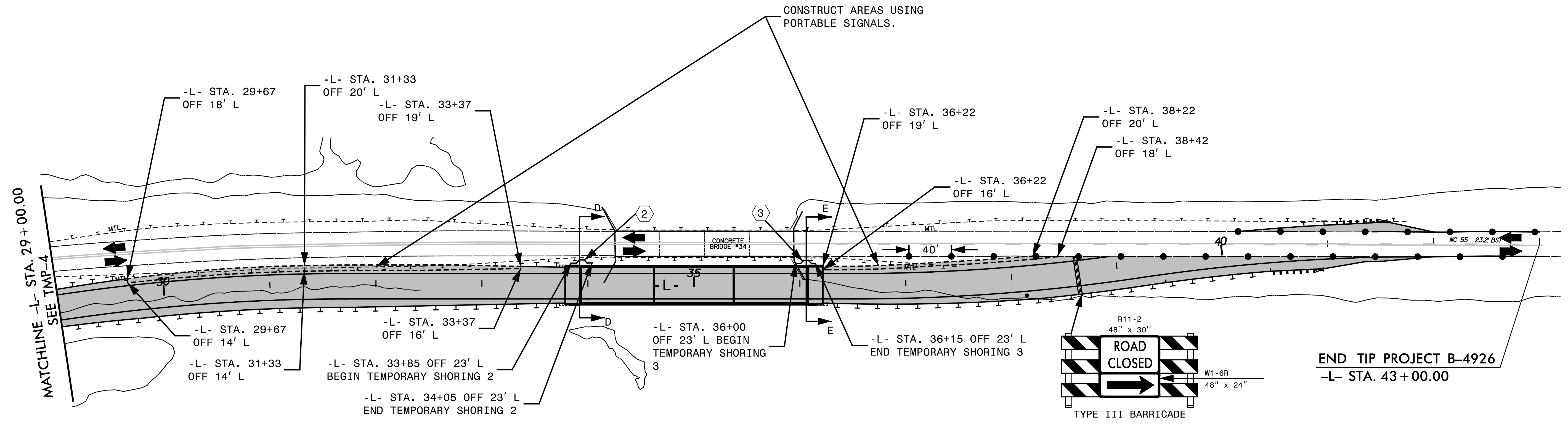
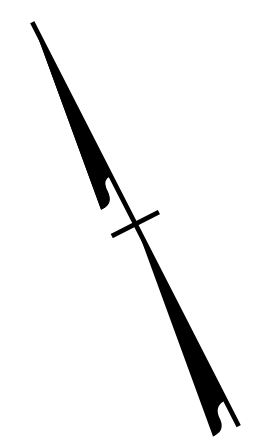

4/4/2004 10:08:58 EB:015.00.B-4926.TP.Traffic\TMP-B-4926.TMP-5.dgn

TRANSYSTEMS
1 Glenwood Avenue
Raleigh, NC 27603
Tel: 919.789.9977
Fax: 919.789.9591
License: F-0453

APPROVED: Steve Miller
DATE: _____
SEAL

DocuSigned by:
Steve Miller
9fbc9c1scEEB486...

SEAL
037026
ENGINEER
STEVEN D. MILLER

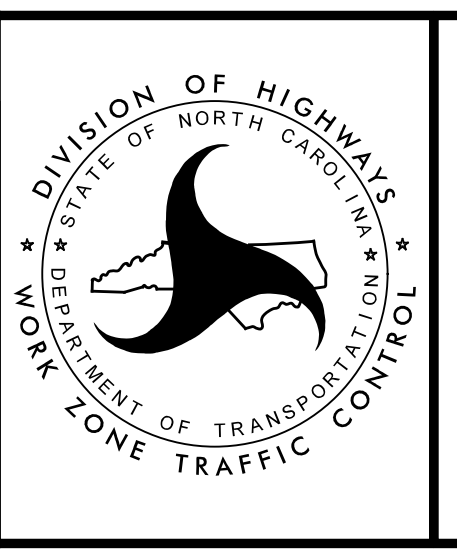

PHASE I

DOCUMENT NOT CONSIDERED FINAL
UNLESS ALL SIGNATURES COMPLETED