

2/13/2024
 \\wef-fs01\projects\2021\2147.07_HB-0002_Traffic_Traffic_Design\Pre-Let\Plan\Pavement_Markings\HB-0002_PMP_01.dgn
 User: AHayes

CONTRACT: N/A T.I.P.: HB-0002

**STATE OF NORTH CAROLINA
 DEPARTMENT OF TRANSPORTATION**

**PAVEMENT MARKING PLAN
 HAYWOOD COUNTY**

TIP NO. HB-0002	SHEET NO. PMP-01
APPROVED:	
DATE: 2/13/2024	
DOCUMENT NOT CONSIDERED FINAL UNLESS ALL SIGNATURES COMPLETED	

INDEX

SHEET NO.	DESCRIPTION
PMP-01	PAVEMENT MARKING PLAN TITLE AND SCHEDULE SHEET
PMP-02 - 03	PAVEMENT MARKING DETAIL

ROADWAY STANDARD DRAWING

THE FOLLOWING ROADWAY STANDARDS AS APPEAR IN "ROADWAY STANDARD DRAWINGS" - PROJECT SERVICES UNIT - N.C. DEPARTMENT OF TRANSPORTATION - RALEIGH, N.C., DATED JANUARY 2024 ARE APPLICABLE TO THIS PROJECT AND BY REFERENCE HEREBY ARE CONSIDERED A PART OF THESE PLANS:

STD. NO.	TITLE
1205.01	PAVEMENT MARKINGS - LINE TYPES AND OFFSETS
1205.02	PAVEMENT MARKINGS - TWO-LANE AND MULTILANE ROADWAYS
1205.04	PAVEMENT MARKINGS - INTERSECTIONS
1261.01	GUARDRAIL AND BARRIER DELINEATORS - INSTALLATION SPACING
1262.01	GUARDRAIL END DELINEATION
1264.01	OBJECT MARKERS - TYPES
1264.02	OBJECT MARKERS - INSTALLATION

FINAL PAVEMENT MARKING SCHEDULE

SYMBOL	DESCRIPTION	PAY ITEM
T1	WHITE SOLID EDGE LINE	THERMOPLASTIC (4", 90 MIL)
T5	2 FT. - 6 FT./SP WHITE MINISKIP	THERMOPLASTIC (4", 90 MIL)
T13	YELLOW DOUBLE CENTER	THERMOPLASTIC (4", 90 MIL)
T20	WHITE SOLID EDGE LINE	THERMOPLASTIC (6", 90 MIL)
T22	10 FT. - 30 FT./SP WHITE SKIP	THERMOPLASTIC (6", 90 MIL)
T30	YELLOW EDGELINE	THERMOPLASTIC (6", 90 MIL)
T61	WHITE STOPBAR	THERMOPLASTIC (24", 90 MIL)
MF	CRYSTAL & RED	NON-CAST IRON SNOWPLOWABLE MARKER

PLAN SUBMITTED TO:

ZACH SHULER

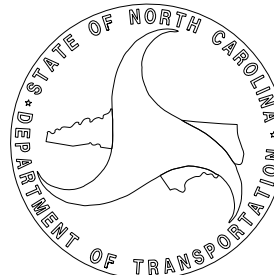

GENERAL NOTES

THE FOLLOWING GENERAL NOTES APPLY AT ALL TIMES FOR THE DURATION OF THE CONSTRUCTION PROJECT, EXCEPT WHEN OTHERWISE NOTED IN THE PLAN, OR DIRECTED BY THE ENGINEER.

- A) INSTALL PAVEMENT MARKINGS AND PAVEMENT MARKERS ON THE FINAL SURFACE AS FOLLOWS:

ROAD NAME	MARKING	MARKER
I-40	THERMOPLASTIC	NON-CAST IRON SNOWPLOWABLE
-Y- LINES	THERMOPLASTIC	NONE
- B) TIE PROPOSED PAVEMENT MARKING LINES TO EXISTING PAVEMENT MARKING LINES.
- C) REMOVE/REPLACE ANY CONFLICTING/DAMAGED PAVEMENT MARKINGS AND MARKERS.
- D) PASSING ZONES WILL BE DETERMINED IN THE FIELD AND MUST BE APPROVED BY THE ENGINEER.
- E) STOP BAR LOCATION AT NON-SIGNALIZED INTERSECTIONS MAY BE ADJUSTED AS DIRECTED BY THE ENGINEER.
- F) UNLESS OTHERWISE SPECIFIED, HEATED-IN-PLACE THERMOPLASTIC MAY BE USED IN LIEU OF COLD APPLIED PLASTIC FOR STOP BARS, SYMBOLS, CHARACTERS AND DIAGONALS ON ASPHALT OR CONCRETE ROADWAYS. IF HEATED-IN-PLACE IS USED, IT SHALL BE PAID FOR USING THE COLD APPLIED PAY ITEM.
- G) ALL STATION ARE CONSIDERED +/- UNLESS OTHERWISE SHOWN ON THE PLANS.



PLAN PREPARED BY: Wetherill Engineering, Inc.

JONATHAN HEFNER, P.E. PROJECT MANAGER
D. ALLEN HAYES, E.I. TRAFFIC DESIGN ENGINEER

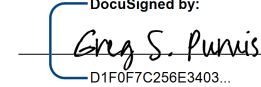

1223 Jones Franklin Rd.
 Raleigh, N.C. 27606
 License No. F-0377
 Bus: 919 851 8077
 Fax: 919 851 8107

TRANSPORTATION PLANNING/DESIGN - BRIDGE/STRUCTURE DESIGN
 CIVIL/SITE DESIGN - GIS/GPS - CONSTRUCTION OBSERVATION

TIP NO. HB-0002	SHEET NO. PMP-02
APPROVED:  DATE: 2/13/2024	
SEAL 	
DOCUMENT NOT CONSIDERED FINAL UNLESS ALL SIGNATURES COMPLETED	

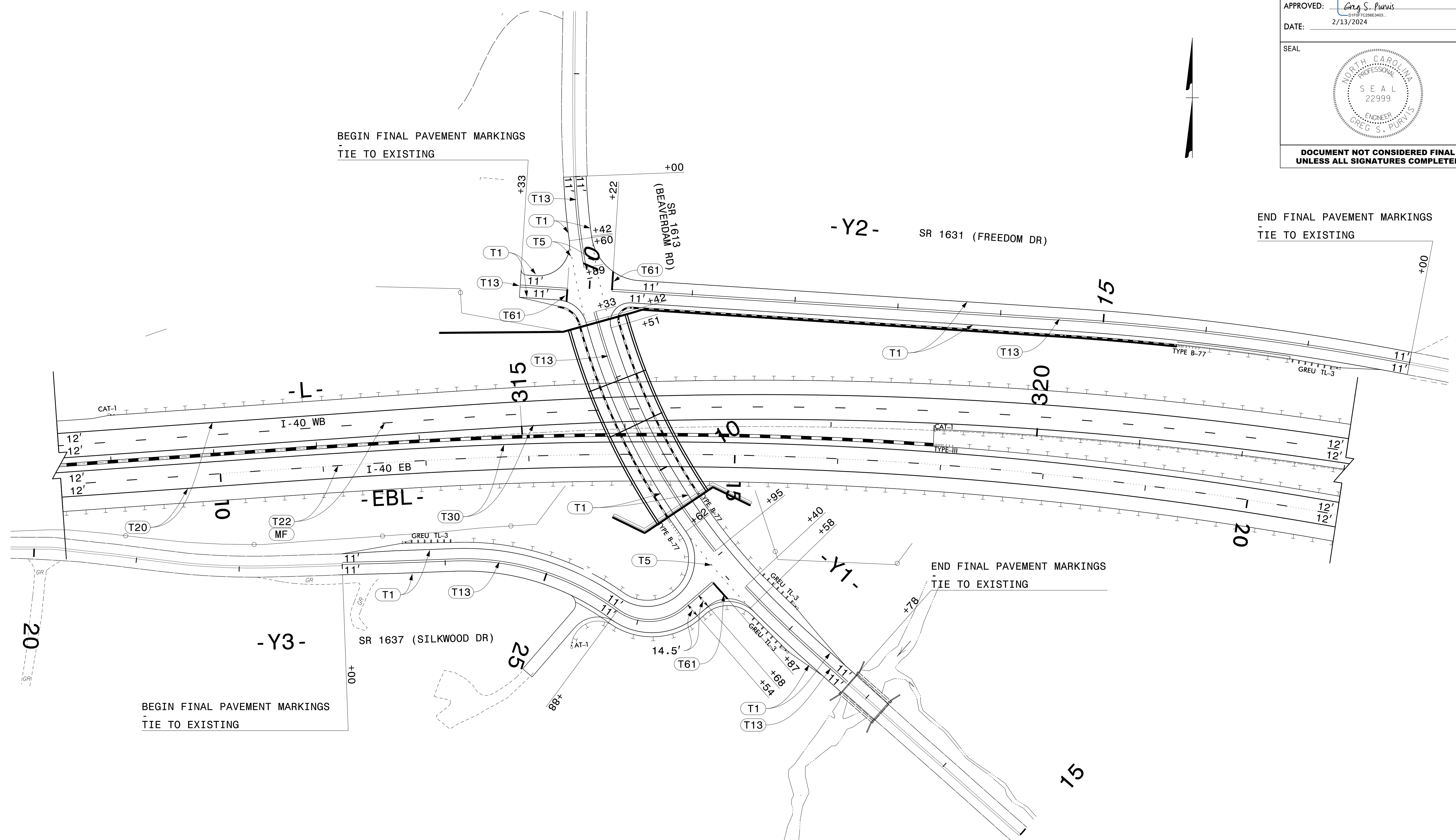

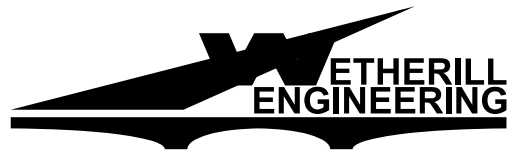

2/13/2024
 \\wef-fs01\projects\2021\2147.07_HB-0002\Traffic\Traffic Design\Pre-Let\Plan\Pavement Markings\HB-0002_PMP_02.dgn
 User: AHAYES



1223 Jones Franklin Rd.
 Raleigh, N.C. 27606
 License No. F-0377
 Bus: 919 851 8077
 Fax: 919 851 8107

TRANSPORTATION PLANNING/DESIGN - BRIDGE/STRUCTURE DESIGN
 CIVIL/SITE DESIGN - GIS/GPS - CONSTRUCTION OBSERVATION

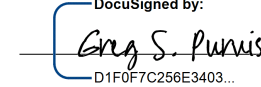
PAVEMENT MARKING DETAIL

TIP NO. HB-0002	SHEET NO. PMP-03
APPROVED:  DATE: 2/13/2024	
SEAL 	
DOCUMENT NOT CONSIDERED FINAL UNLESS ALL SIGNATURES COMPLETED	

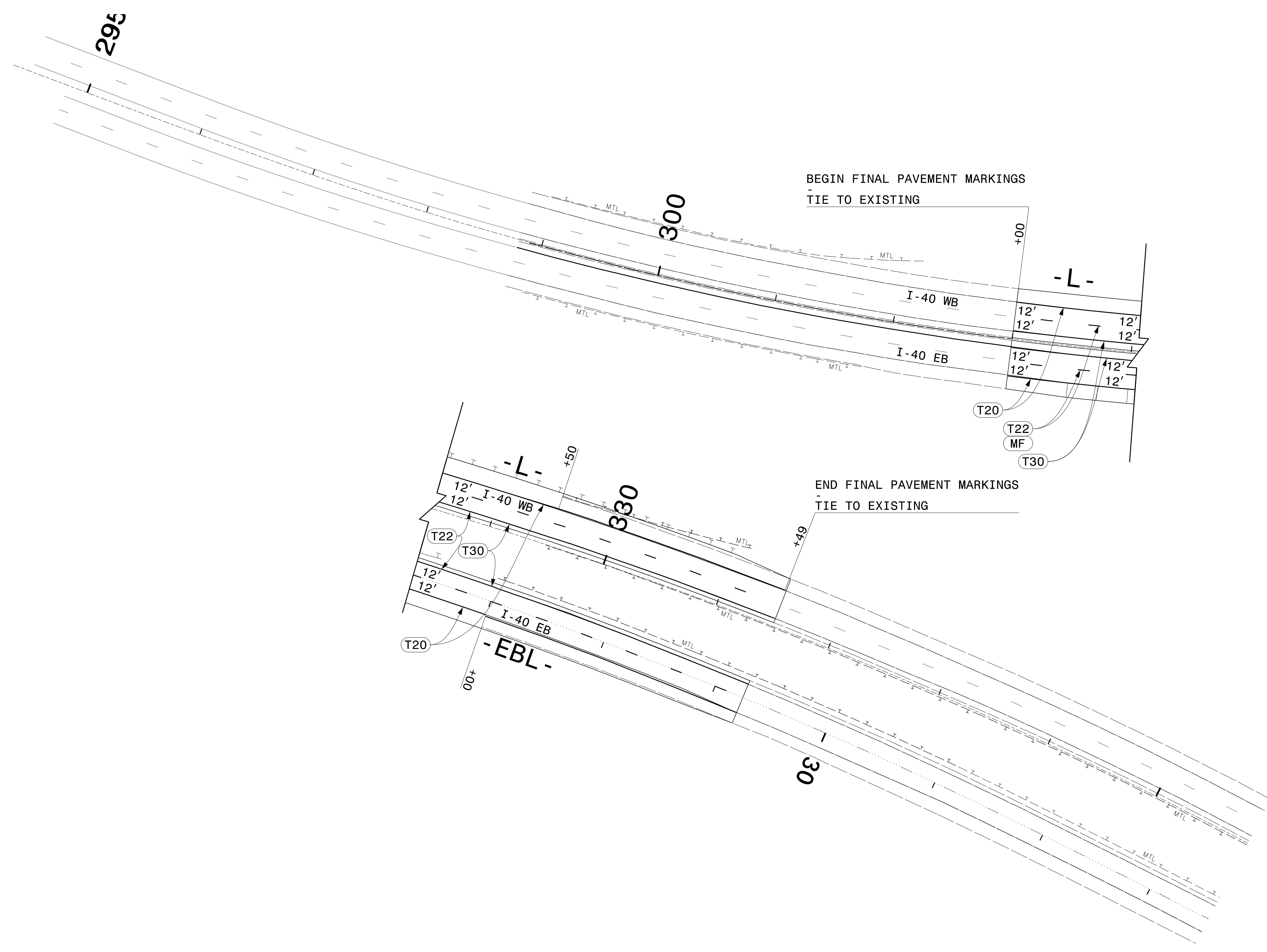

2/13/2024
\\wef-esc01\projects\2021\2147.07_HB-0002\Traffic\Traffic\Design\Pre-Let\Plan\Pavement Markings\HB-0002_PMP_03.dgn
User: AHayes

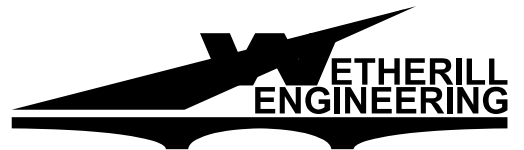

1223 Jones Franklin Rd.
Raleigh, N.C. 27606
License No. F-0377
Bus: 919 851 8077
Fax: 919 851 8107

TRANSPORTATION PLANNING/DESIGN - BRIDGE/STRUCTURE DESIGN
CIVIL/SITE DESIGN - GIS/GPS - CONSTRUCTION OBSERVATION

PAVEMENT MARKING DETAIL