

DEFAULT PHASING DIAGRAM

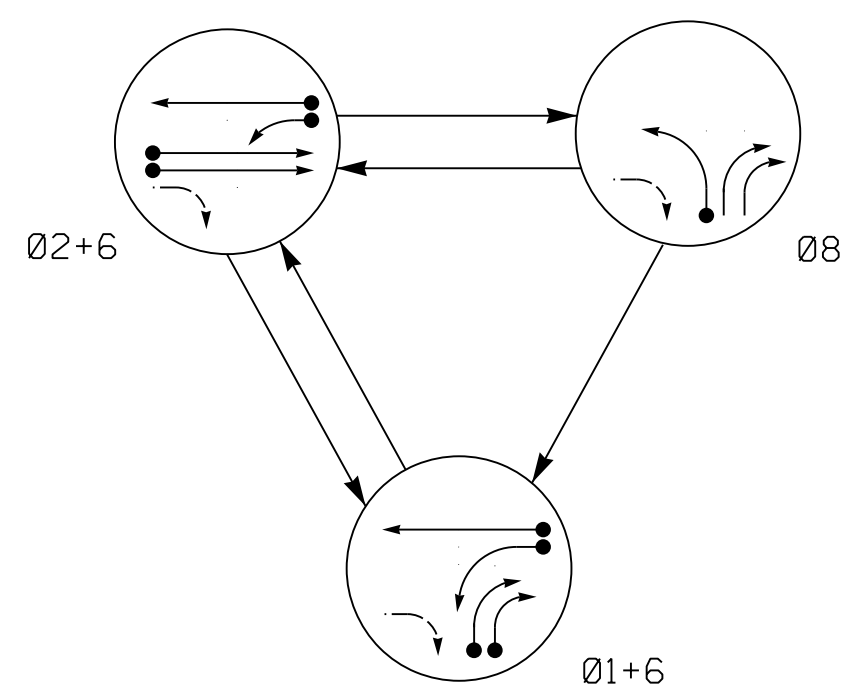

ALTERNATE PHASING DIAGRAM

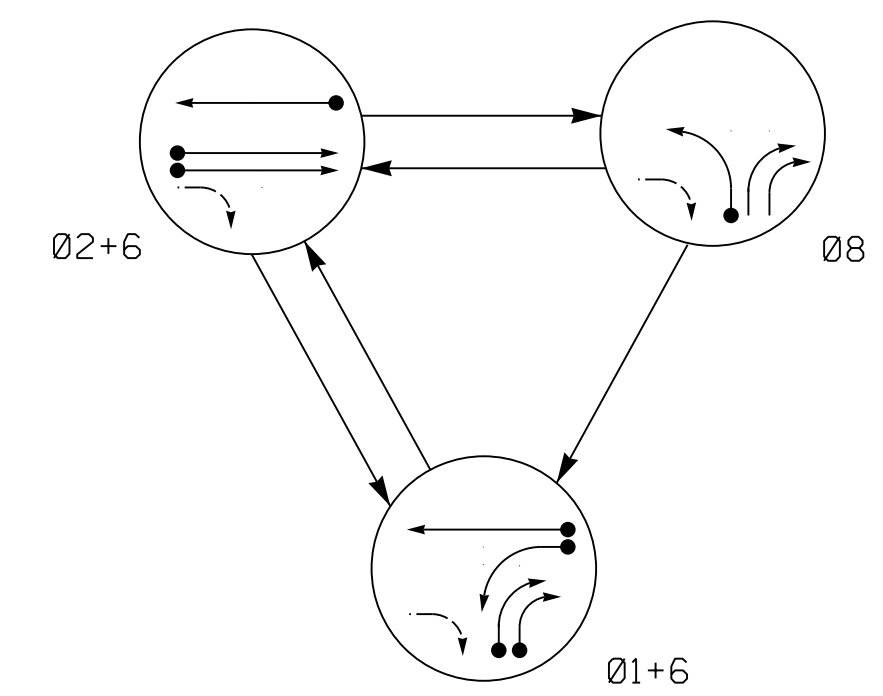

DEFAULT PHASING TABLE OF OPERATION

SIGNAL FACE	PHASE			
	Ø 1 + 6	Ø 2 + 6	Ø 8	F L S H
11	←	←	←	←
12,13	→	→	→	→
21	←	↑	←	←
22	←	↑	←	←
61,62	←	←	←	←
81	←	←	←	←

ALTERNATE PHASING TABLE OF OPERATION

SIGNAL FACE	PHASE			
	Ø 1 + 6	Ø 2 + 6	Ø 8	F L S H
11	←	←	←	←
12,13	→	→	→	→
21	←	↑	←	←
22	←	↑	←	←
61,62	←	←	←	←
81	←	←	←	←

MAXTIME DETECTOR INSTALLATION CHART

LOOP/ZONE	SIZE (FT)	DISTANCE FROM STOPBAR (FT)	TURNS	NEW LOOP	PROGRAMMING							
					CALL PHASE	DELAY TIME	EXTEND TIME	EXTEND	ADDED INITIAL	CALL	DELAY DURING GREEN	NEW CARD
1A	6X40	0	2-4-2	-	1	15#	-	X	-	X	-	-
1B	6X40	0	2-4-2	-	1	15	-	X	-	X	-	-
1C	6X40	0	2-4-2	-	1	15	-	X	-	X	-	-
1D	6X15	0	4	-	1	15	-	X	-	X	-	-
2A*	6X6	300	*	*	2	-	-	X	X	X	-	*
2B*	6X6	300	*	*	2	-	-	X	X	X	-	*
6A*	6X6	300	*	*	6	-	-	X	X	X	-	*
8B	6X40	0	2-4-2	-	8	-	-	X	-	X	-	-

3 Phase Fully Actuated (US 158 Signal System) Signal System #: D09-11\_Winston-Salem

- NOTES
- Refer to "Roadway Standard Drawings NCDOT" dated January 2024 and "Standard Specifications for Roads and Structures" dated January 2024.
  - Do not program signal for late night flashing operation unless otherwise directed by the Engineer.
  - Phase 1 may be lagged.
  - Reposition existing signal heads numbered 61 and 62.
  - Set all detector units to presence mode.
  - This intersection uses video detection. Install detectors according to the manufacturer's instructions to achieve the desired detection.
  - The Division Traffic Engineer will determine the hours of use for each phasing plan.
  - Maximum times shown in timing chart are for free-run operation only. Coordinated signal system timing values supersede these values.

SIGNAL FACE I.D.

All Heads L.E.D.

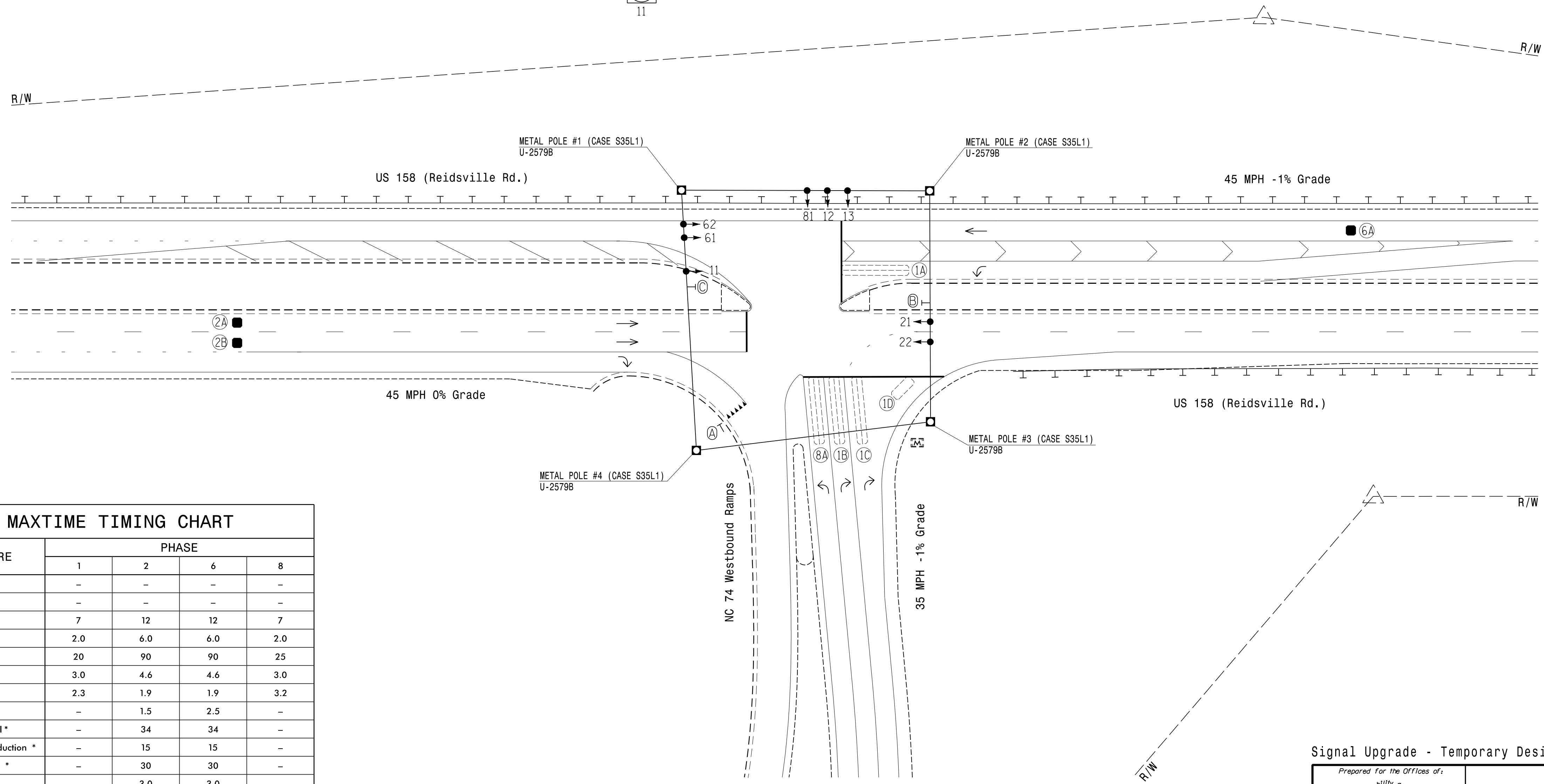
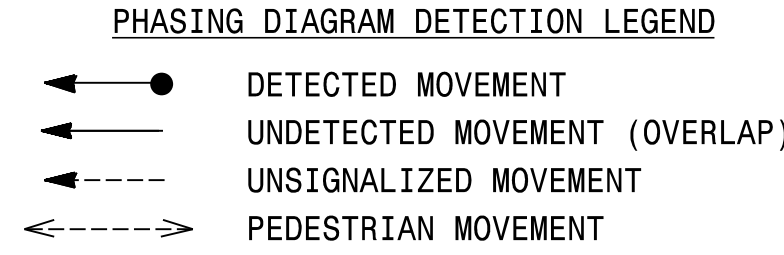
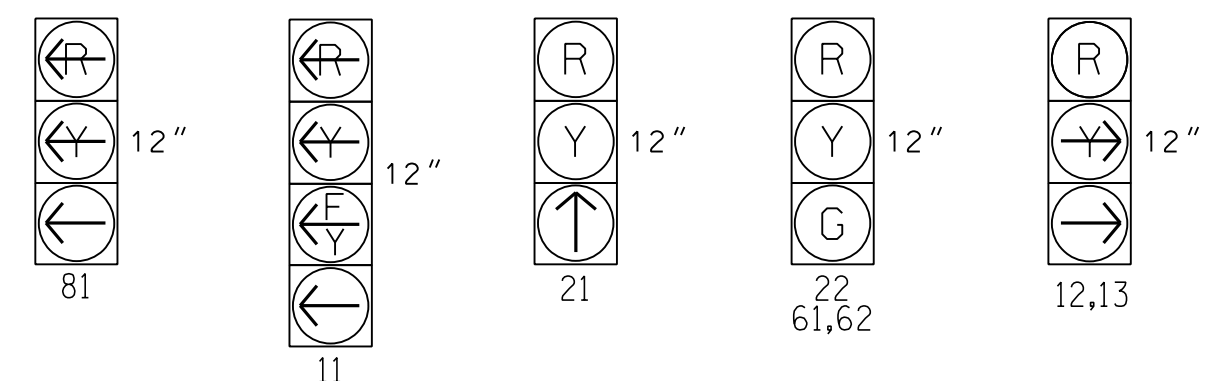

MAXTIME TIMING CHART

FEATURE	PHASE			
	1	2	6	8
Walk *	-	-	-	-
Ped Clear *	-	-	-	-
Min Green	7	12	12	7
Passage *	2.0	6.0	6.0	2.0
Max 1 *	20	90	90	25
Yellow Change	3.0	4.6	4.6	3.0
Red Clear	2.3	1.9	1.9	3.2
Added Initial *	-	1.5	2.5	-
Maximum Initial *	-	34	34	-
Time Before Reduction *	-	15	15	-
Time To Reduce *	-	30	30	-
Minimum Gap	-	3.0	3.0	-
Advance Walk	-	-	-	-
Non Lock Detector	X	-	-	X
Vehicle Recall	-	MIN RECALL	MIN RECALL	-
Dual Entry	-	-	-	-

\* These values may be field adjusted. Do not adjust Min Green and Extension times for phases 2 and 6 lower than what is shown. Min Green for all other phases should not be lower than 4 seconds.

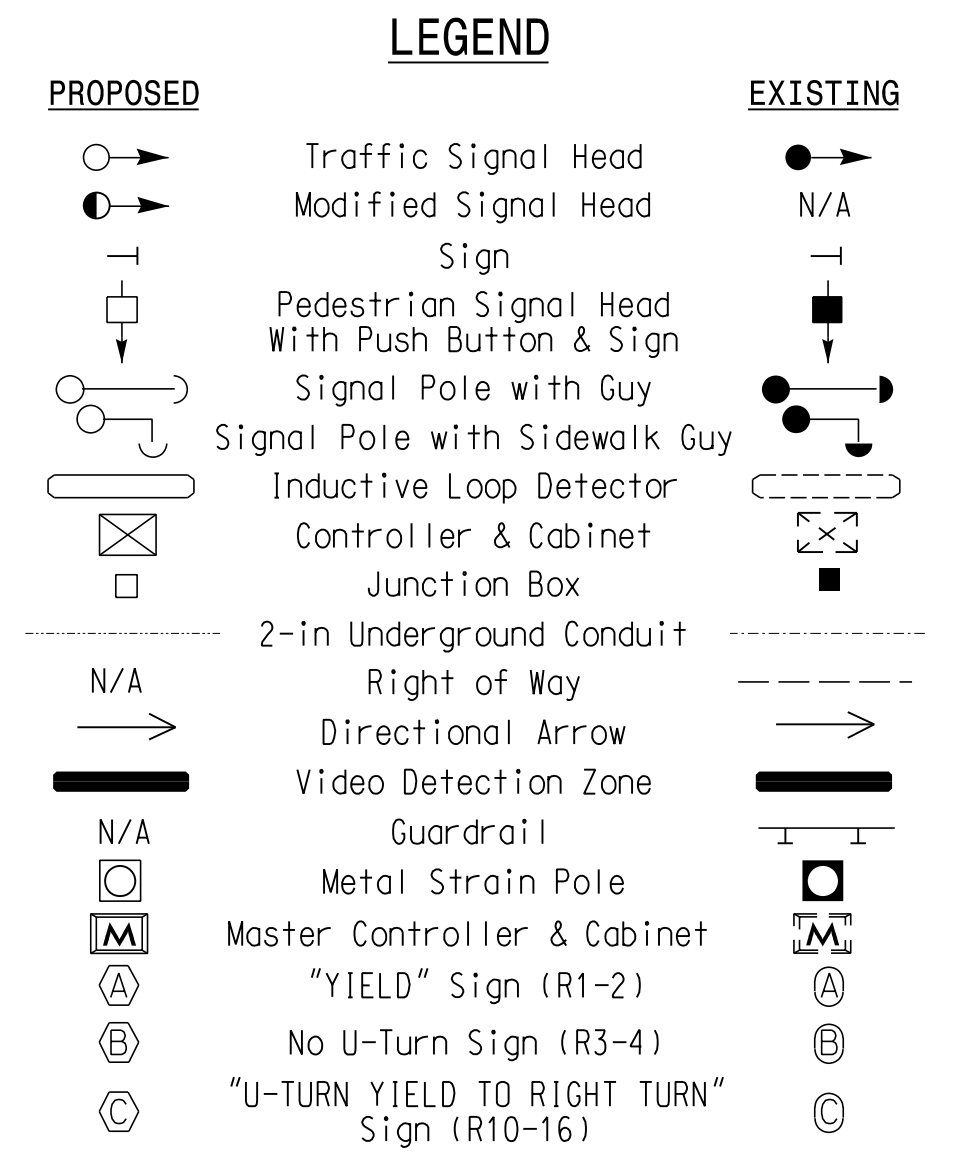

Signal Upgrade - Temporary Design 2 (TMP Phases I Step 3-II)

**RK&K**  
 P: (919) 878-9550  
 8801 Six Forks Road Suite 700 | Raleigh, North Carolina 27615-2965  
 NC License No. F-0112  
 Engineers | Construction Managers | Planners | Scientists  
 www.rk.com  
 Responsive People | Creative Solutions

Prepared for the Offices of:  
 Transportation Mobility and Safety Solutions  
 NORTH CAROLINA DEPARTMENT OF TRANSPORTATION  
 SIGNAL DESIGN SECTION  
 750 N. Greenfield Pkwy, Garner, NC 27529

US 158 (Reidsville Rd.) at NC 74 Westbound Ramps  
 Division 9 Forsyth County Winston-Salem  
 PLAN DATE: February 2024 REVIEWED BY: DT Sears  
 PREPARED BY: WP Erickson-Jones REVIEWED BY:

REVISIONS	INIT.	DATE

DOCUMENT NOT CONSIDERED FINAL UNLESS ALL SIGNATURES COMPLETED

SEAL  
 NORTH CAROLINA PROFESSIONAL ENGINEER  
 SEAL 056142  
 W. PORTER JONES  
 PORTER JONES ENGINEERS  
 2/12/2024  
 SIGNATURE DATE  
 SIG. INVENTORY NO. 09-05112

2/12/2024  
 R:\Traffic\c4s1\gnal\04051112.dwg den...XXXXXX.dgn  
 wplones