

18 CHANNEL IP CONFLICT MONITOR PROGRAMMING DETAIL

(remove jumpers and set switches as shown)

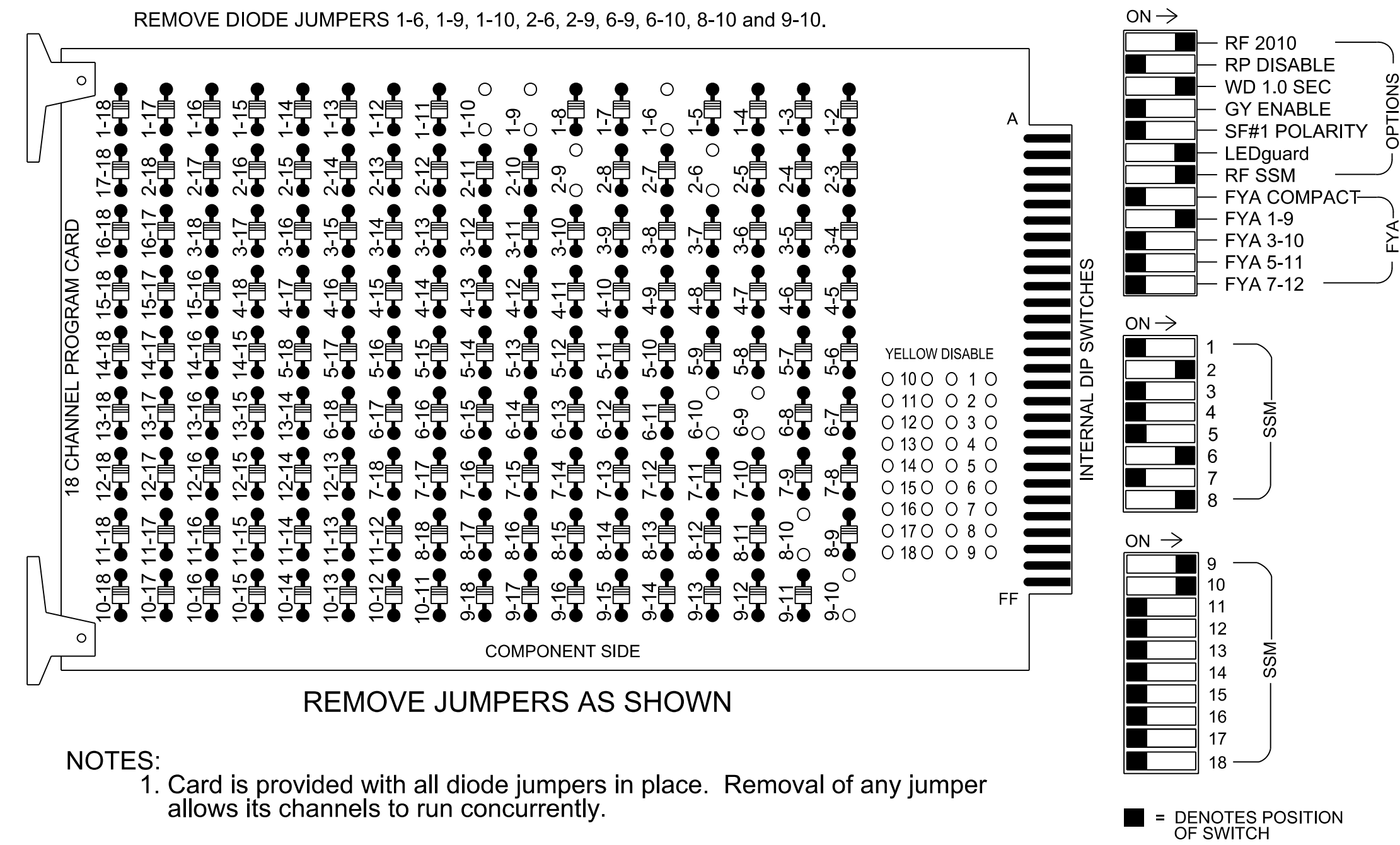

- REMOVE DIODE JUMPERS 1-6, 1-9, 1-10, 2-6, 2-9, 6-9, 6-10, 8-10 and 9-10.
- REMOVE JUMPERS AS SHOWN
- NOTES:
- Card is provided with all diode jumpers in place. Removal of any jumper allows its channels to run concurrently.
 - Ensure jumpers SEL2-SEL5 and SEL9 are present on the monitor board.
 - Ensure that the Red Enable is active at all times during normal operation.
 - Integrate monitor with Ethernet network in cabinet.

NOTES

- To prevent "flash-conflict" problems, insert red flash program blocks for all unused vehicle load switches in the output file. The installer shall verify that signal heads flash in accordance with the signal plan.
- Program controller to start up in phase 2 Green No Walk and 6 Green No Walk.
- If this signal will be managed by an ATMS software, enable controller and detector logging for all detectors used at this location.
- The cabinet and controller are part of the US 158 Signal Sytem, Signal System : D09-11_Winston-Salem System.

EQUIPMENT INFORMATION

Controller.....2070LX
 Cabinet.....332 w/ Aux
 Software.....Q-Free MAXTIME
 Cabinet Mount.....Base
 Output File Positions.....18 With Aux. Output File
 Load Switches Used.....S1, S2, S8, S11, AUX S1, AUX S2
 Phases Used.....1, 2, 6, 8
 Overlap "1".....*
 Overlap "2".....*
 Overlap "3".....NOT USED
 Overlap "4".....NOT USED
 *See overlap programming detail on sheet 2.

SIGNAL HEAD HOOK-UP CHART

LOAD SWITCH NO.	S1	S2	S3	S4	S5	S6	S7	S8	S9	S10	S11	S12	AUX S1	AUX S2	AUX S3	AUX S4	AUX S5	AUX S6
CMU CHANNEL NO.	1	2	13	3	4	14	5	6	15	7	8	16	9	10	17	11	12	18
PHASE	1	2	2 PED	3	4	4 PED	5	6	6 PED	7	8	8 PED	OL1	OL2	SPARE	OL3	OL4	SPARE
SIGNAL HEAD NO.	11*	21	22	NU	NU	NU	NU	61,62	NU	NU	81	NU	11*	12,13	NU	NU	NU	NU
RED		128	128					134						A124				
YELLOW	*	129	129					135										
GREEN			130					136										
RED ARROW											107			A121				
YELLOW ARROW											108			A122	A125			
FLASHING YELLOW ARROW														A123				
GREEN ARROW	127	130									109							A126

NU = Not Used
 * Denotes install load resistor. See load resistor installation detail this sheet.
 * See pictorial of head wiring in detail this sheet.

INPUT FILE CONNECTION & PROGRAMMING CHART

INPUT FILE POSITION LAYOUT

(front view)

FILE	1	2	3	4	5	6	7	8	9	10	11	12	13	14
U	∅ 1	∅ 1	∅ 1	∅ 1	∅ 1	∅ 1	∅ 1	∅ 1	∅ 1	∅ 1	∅ 1	∅ 1	∅ 1	FS
L	1A	1B	1C	1D	1E	1F	1G	1H	1I	1J	1K	1L	1M	DC ISOLATOR
U	NOT USED	∅ 1	∅ 1	∅ 1	∅ 1	∅ 1	∅ 1	∅ 1	∅ 1	∅ 1	∅ 1	∅ 1	∅ 1	ST
L	1N	1O	1P	1Q	1R	1S	1T	1U	1V	1W	1X	1Y	1Z	DC ISOLATOR

EX.: 1A, 2A, ETC. = LOOP NO.'S

FS = FLASH SENSE
 ST = STOP TIME

LOOP NO.	LOOP TERMINAL	INPUT FILE POS.	PIN NO.	INPUT POINT	DETECTOR NO.	CALL PHASE	DELAY TIME	EXTEND TIME	EXTEND	ADDED INITIAL	CALL	DELAY DURING GREEN
1A	TB2-1,2	I1U	56	18	1	1	15		X		X	
1B	TB2-5,6	I2U	39	-	29	6	3		X		X	X
1C	TB2-7,8	I2L	43	5	3	1	15		X		X	
1D	TB6-9,10	I9U	60	22	13	1	15		X		X	
8A	TB6-11,12	I9L	62	24	14	8			X		X	

REMOVE, jumper from 1-W to J4-W, on rear of input file, if present.

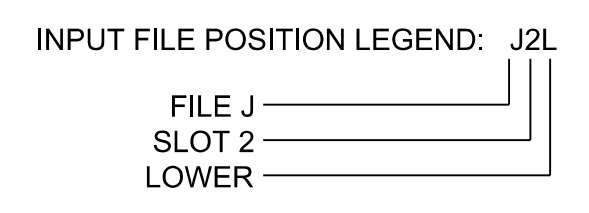

FYA SIGNAL WIRING DETAIL

(wire signal heads as shown)

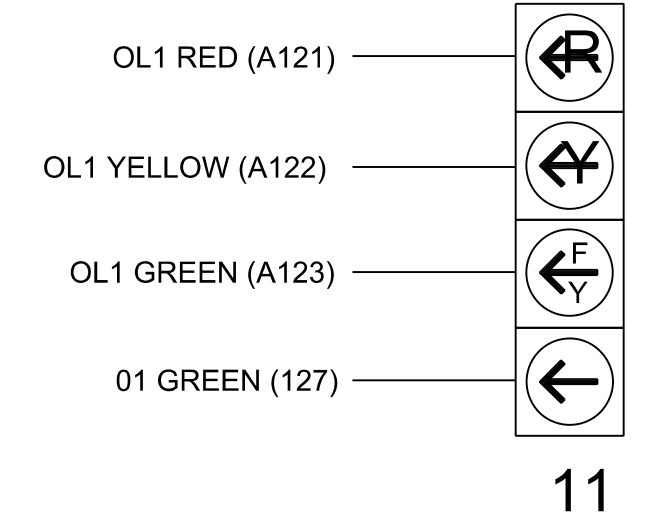

LOAD RESISTOR INSTALLATION DETAIL

(install resistors as shown)

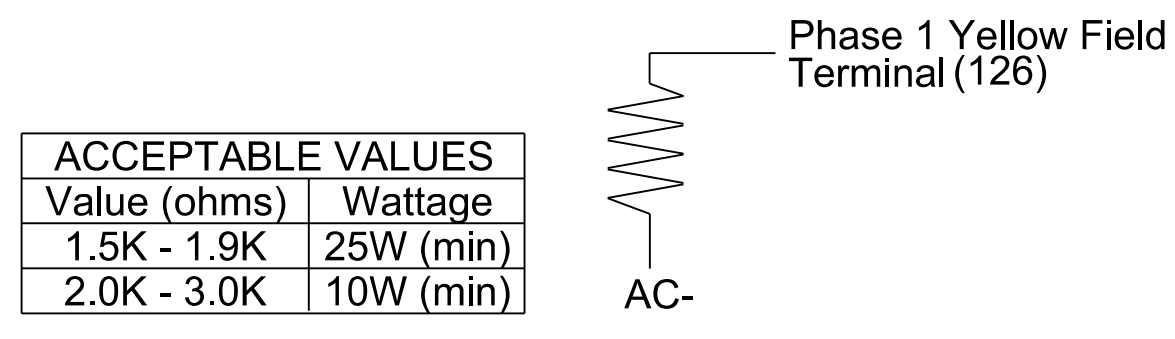

SPECIAL DETECTOR NOTE

Install a video detection system for vehicle detection for zones. 2A, 2B and 6A. Perform installation according to manufacturer's directions and NCDOT engineer -approved mounting locations to accomplish the detection schemes shown on the Signal Design Plans.

THIS ELECTRICAL DETAIL IS FOR THE SIGNAL DESIGN: 09-0511T1
 DESIGNED: February 2024
 SEALED: February 12, 2024
 REVISED:

Signal Upgrade - Temporary Design 1 (TMP Phase I Step 2) Electrical Detail- Sheet 1 of 2

Electrical and Programming Details For:

Prepared for the Offices of:

US 158 (Reidsville Rd.) at NC 74 Westbound Ramps

Division 9 Forsyth County Winston-Salem

PLAN DATE: February 2024 REVIEWED BY: DT Sears

PREPARED BY: WP Erickson-Jones REVIEWED BY:

REVISIONS

NO.	INIT.	DATE

750 N. Greenfield Pkwy, Garner, NC 27529

DOCUMENT NOT CONSIDERED FINAL UNLESS ALL SIGNATURES COMPLETED

Porter Jones 2/12/2024

SIG. INVENTORY NO. 09-0511T1

2/12/2024
 R:\Projects\09-0511T1\Signal\09-0511T1_Sig_dsn_XXXXXX.dgn
 W:\ones