

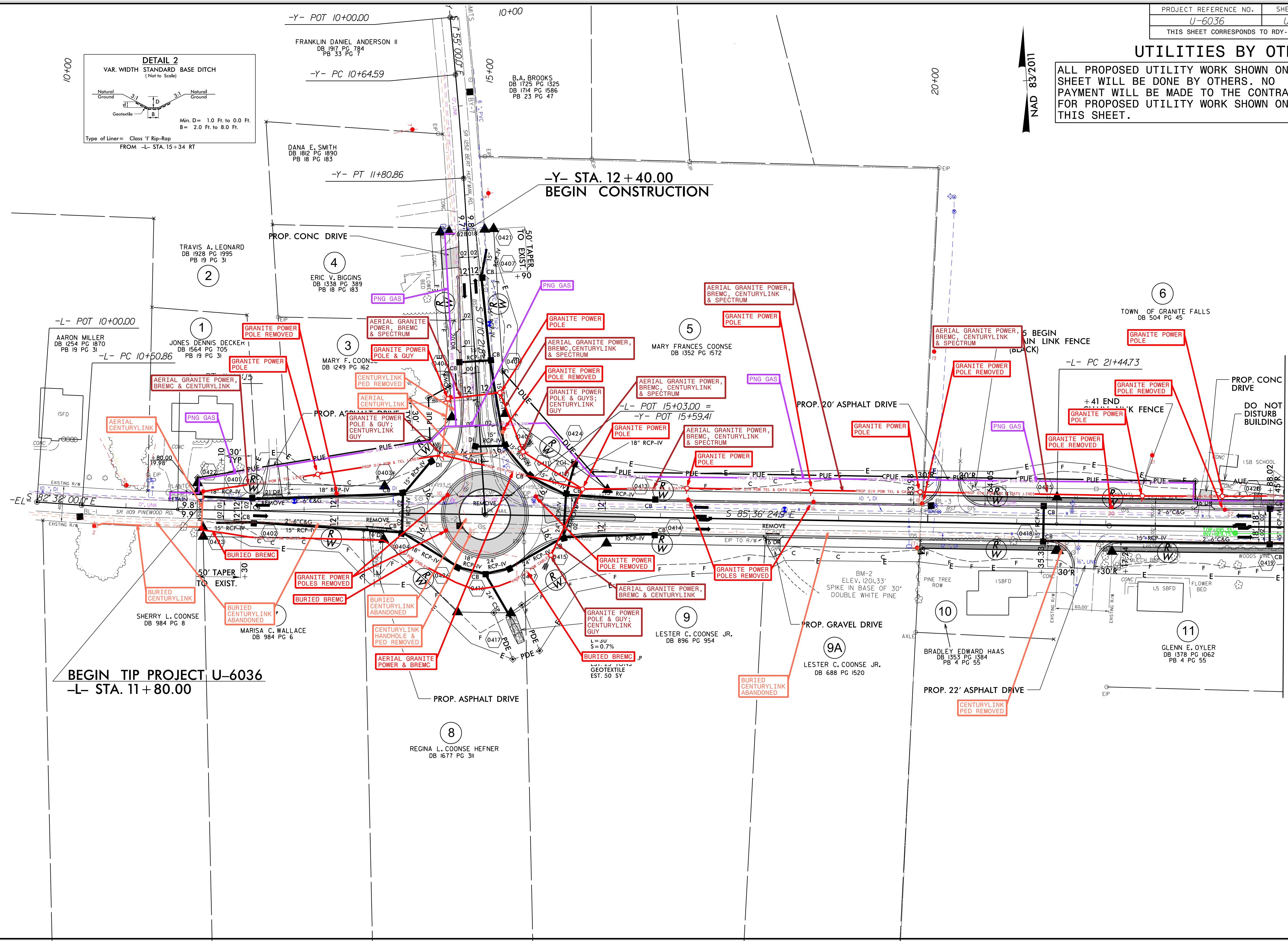

### UTILITIES BY OTHERS

ALL PROPOSED UTILITY WORK SHOWN ON THIS SHEET WILL BE DONE BY OTHERS. NO PAYMENT WILL BE MADE TO THE CONTRACTOR FOR PROPOSED UTILITY WORK SHOWN ON THIS SHEET.

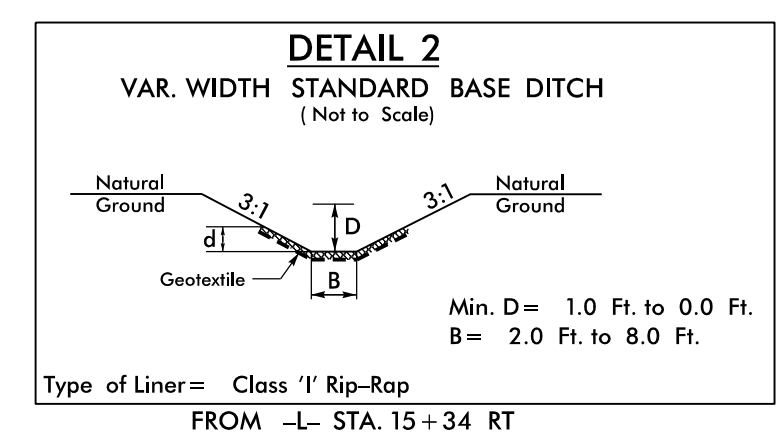

MATCH LINE STA. -L- 24+00  
MATCH TO SHEET UO-3

18-OCT-2023 09:04  
U:\6036\UB05\Utilities\Engineering\UB05\Proj\U-6036-ut-rdy4\_U002\_psh.dgn

### UTILITIES BY OTHERS

ALL PROPOSED UTILITY WORK SHOWN ON THIS SHEET WILL BE DONE BY OTHERS. NO PAYMENT WILL BE MADE TO THE CONTRACTOR FOR PROPOSED UTILITY WORK SHOWN ON THIS SHEET.

5/14/19

HICKORY, NC 28601  
TOWN OF GRANITE FALLS  
P.O. DRAWER 10  
GRANITE FALLS, NC 28630



MATCH LINE STA. -L- 24+00  
MATCH TO SHEET UO-2

MATCH LINE STA. -L- 38+00  
MATCH TO SHEET UO-4

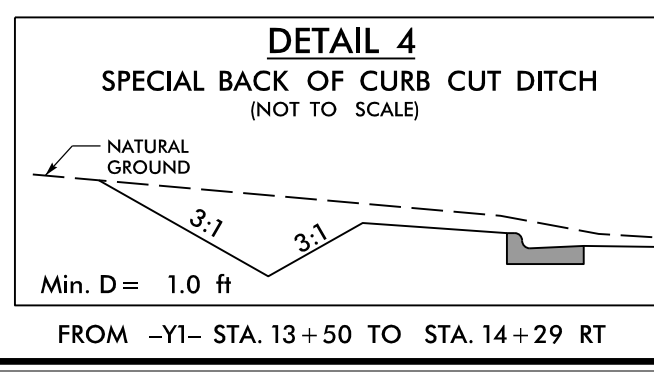
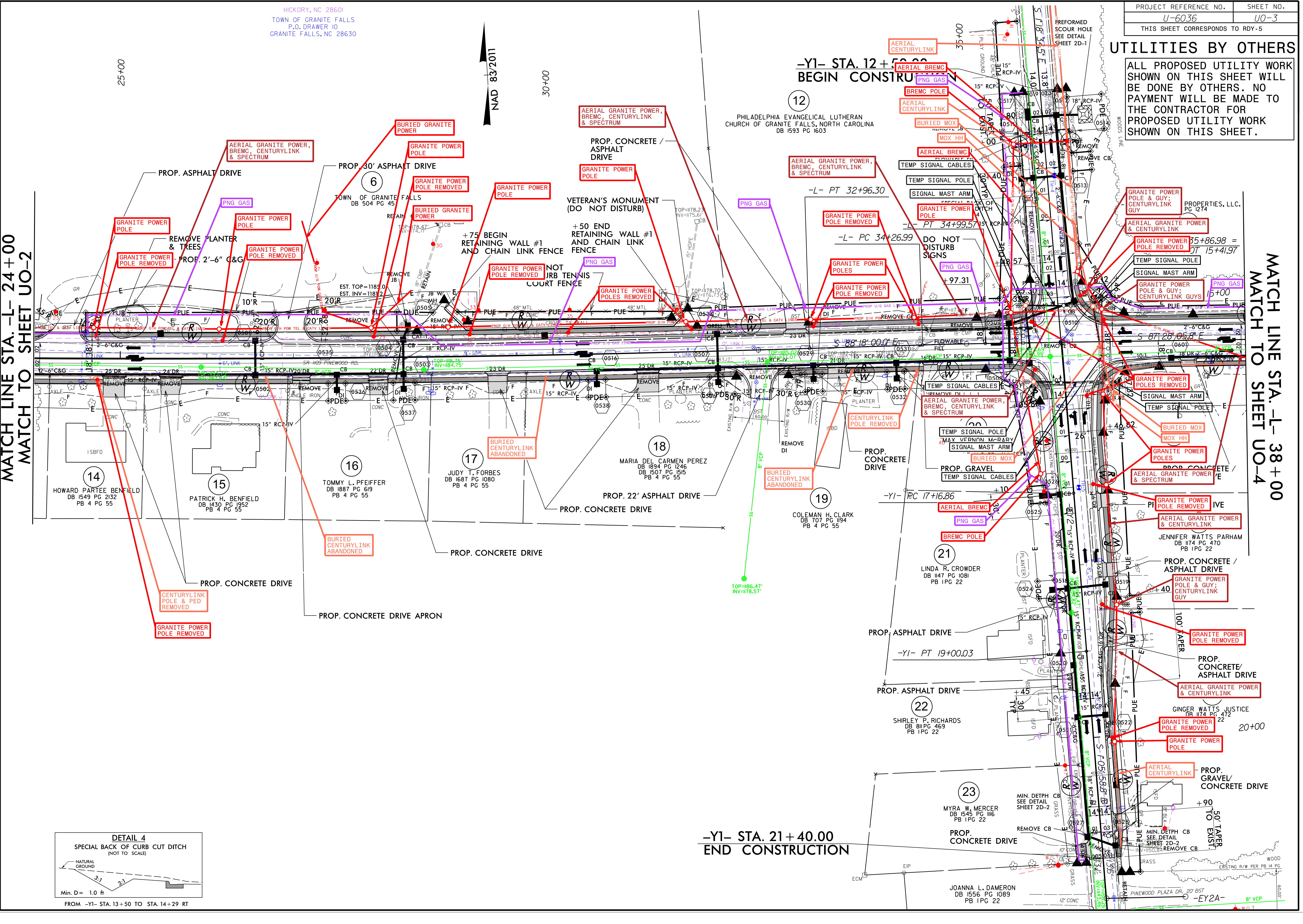

-Y1- STA. 21+40.00  
END CONSTRUCTION

18-OCT-2023 09:08  
 U:\6036\U0-3\Utilities\Engineer.rng\UBCN\Proj\U-6036-ut.-rdy5-U003\_psh.dgn

### UTILITIES BY OTHERS

ALL PROPOSED UTILITY WORK SHOWN ON THIS SHEET WILL BE DONE BY OTHERS. NO PAYMENT WILL BE MADE TO THE CONTRACTOR FOR PROPOSED UTILITY WORK SHOWN ON THIS SHEET.

00.00 10

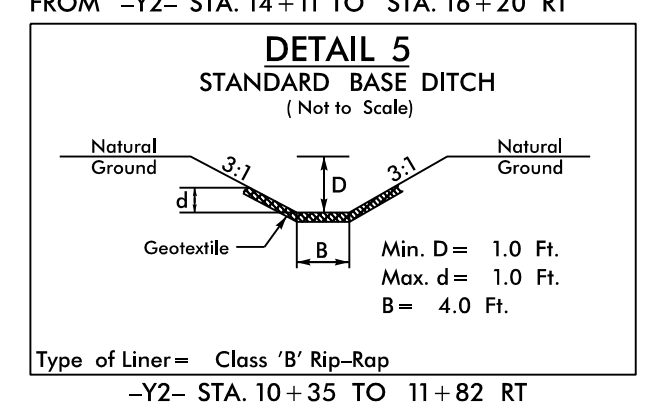
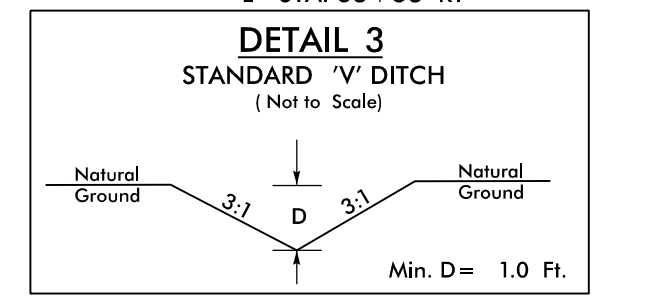
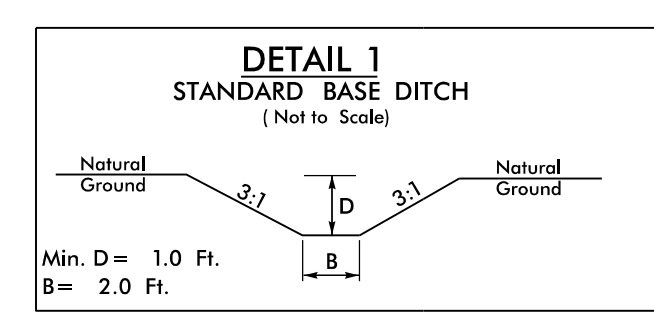

MATCH LINE STA. -L- 38+00  
MATCH TO SHEET U0-3

DRIVE  
POWER  
DITCH

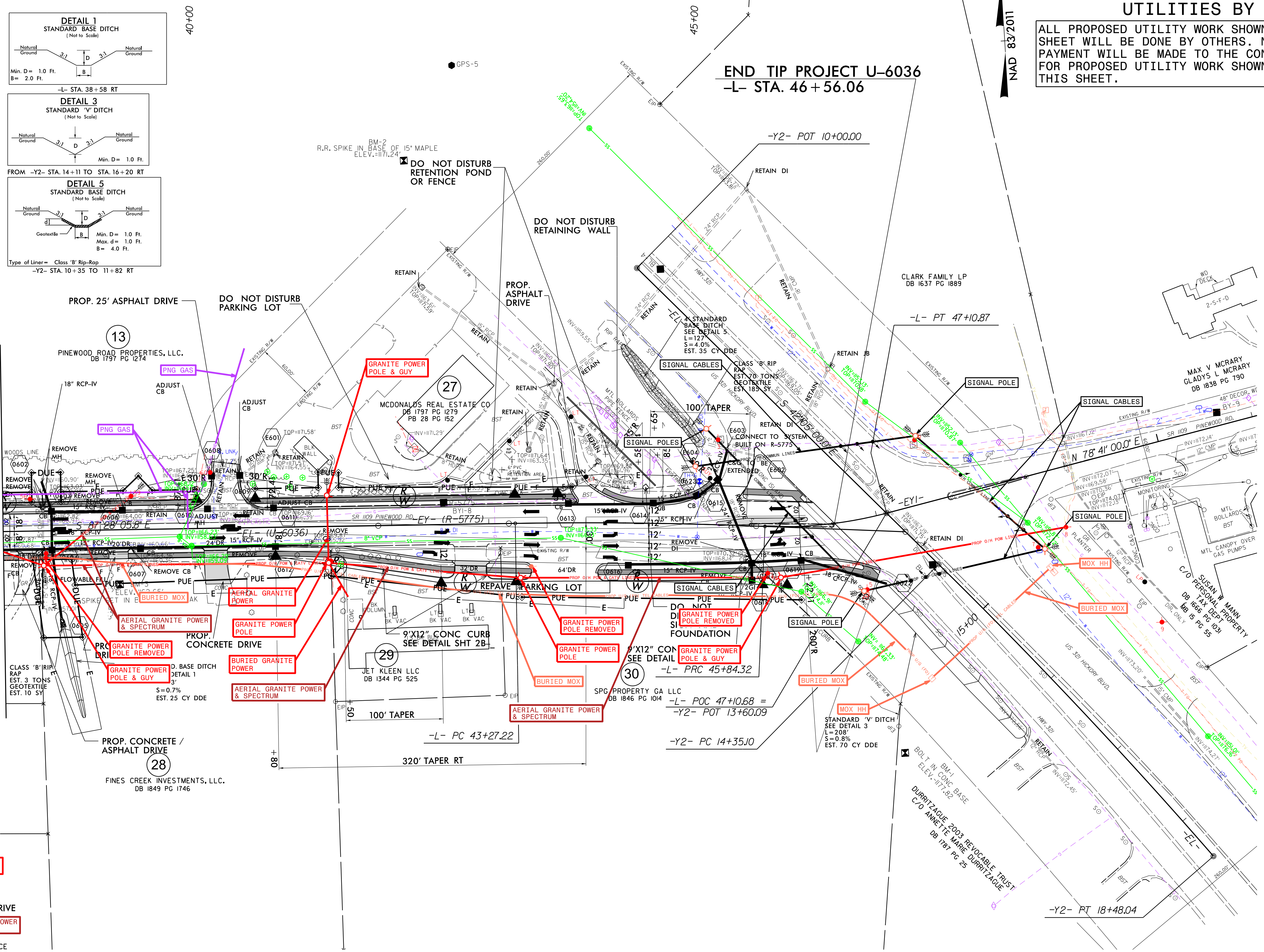

NAD 83/2011

5/14/2019

18-OCT-2023 09:14  
U:\6036\UBD\Utilities\Engineering\UBD\Proj\U-6036.ut\_rdy6\_U004\_psh.dgn  
C:\Users\jenniferm\Documents\Projects\U-6036\Utilities\Engineering\UBD\Proj\U-6036.ut\_rdy6\_U004\_psh.dgn