

PROJECT REFERENCE NO.	UC-3D
SHEET NO.	UC-3D
DESIGNED BY:	SJJ
DRAWN BY:	SCA
CHECKED BY:	MAS
APPROVED BY:	
REVISED:	
NORTH CAROLINA DEPARTMENT OF TRANSPORTATION	
UTILITIES ENGINEERING SECTION	
PHONE: (919) 707-6690	FAX: (919) 250-4151

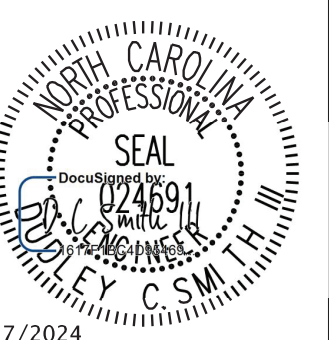

UTILITY CONSTRUCTION

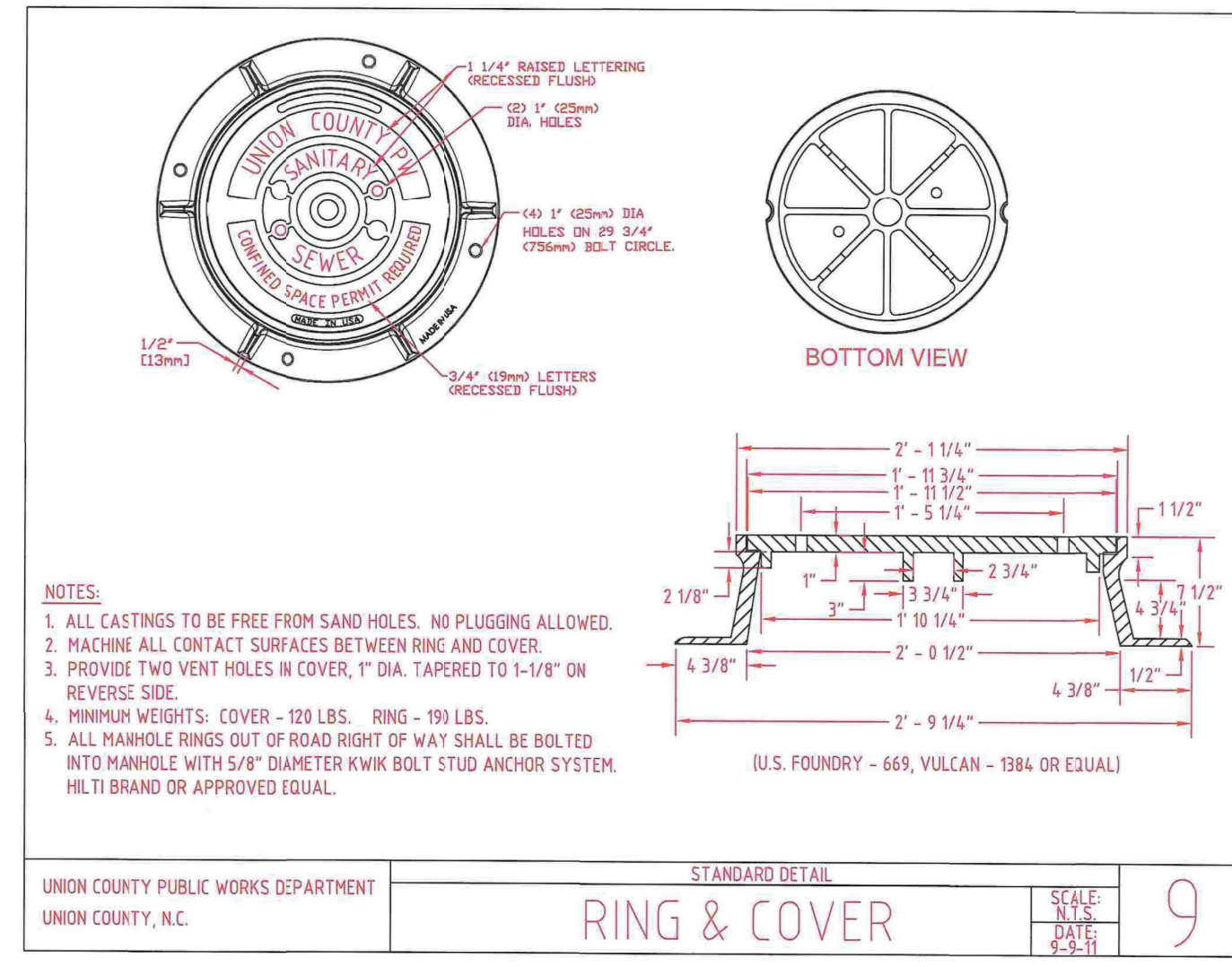

UNION COUNTY PUBLIC WORKS DEPARTMENT
UNION COUNTY, N.C. STANDARD DETAIL
RING & COVER SCALE: N.T.S. DATE: 9-9-11 **9**

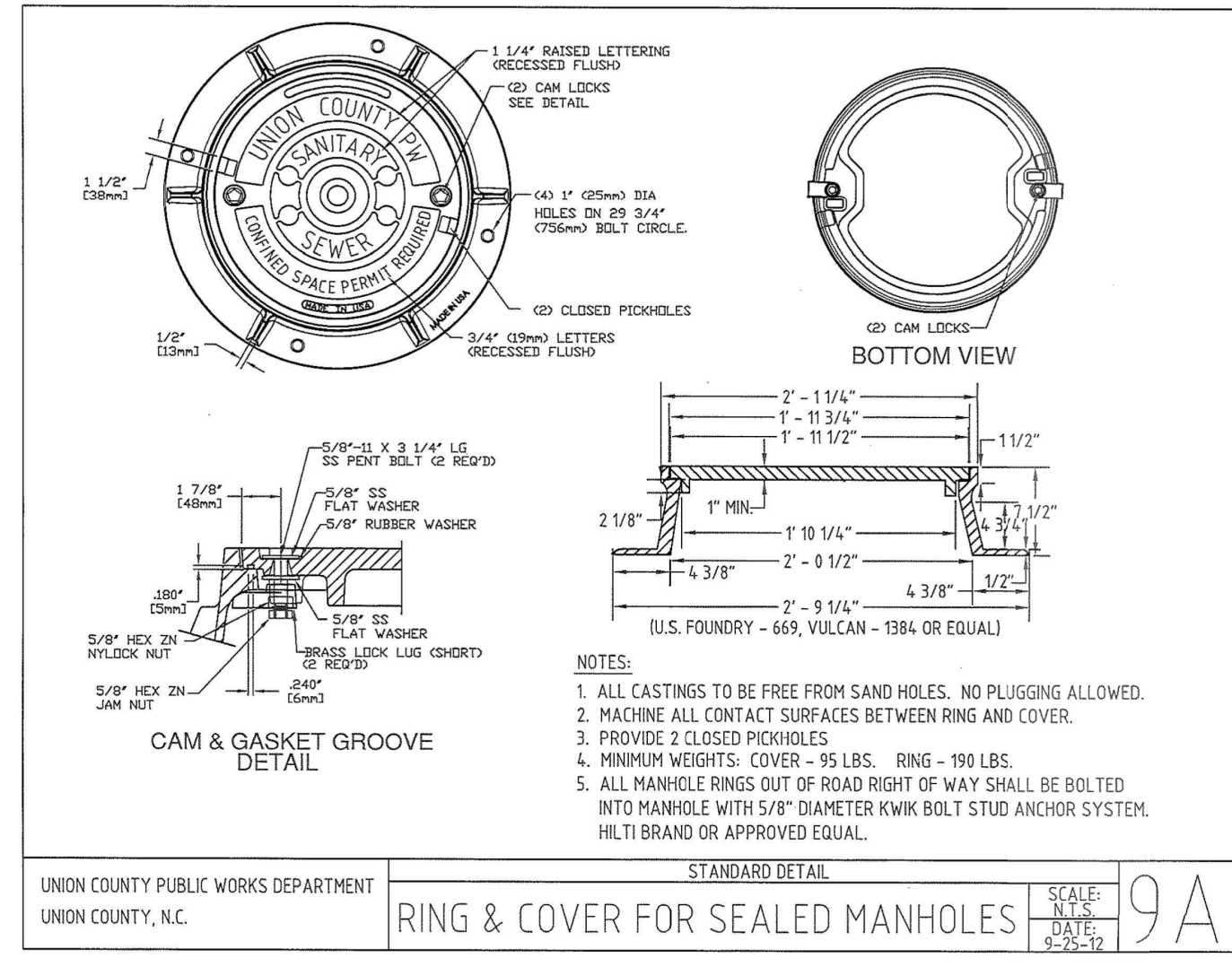

UNION COUNTY PUBLIC WORKS DEPARTMENT
UNION COUNTY, N.C. STANDARD DETAIL
RING & COVER FOR SEALED MANHOLES SCALE: N.T.S. DATE: 9-9-11 **9A**

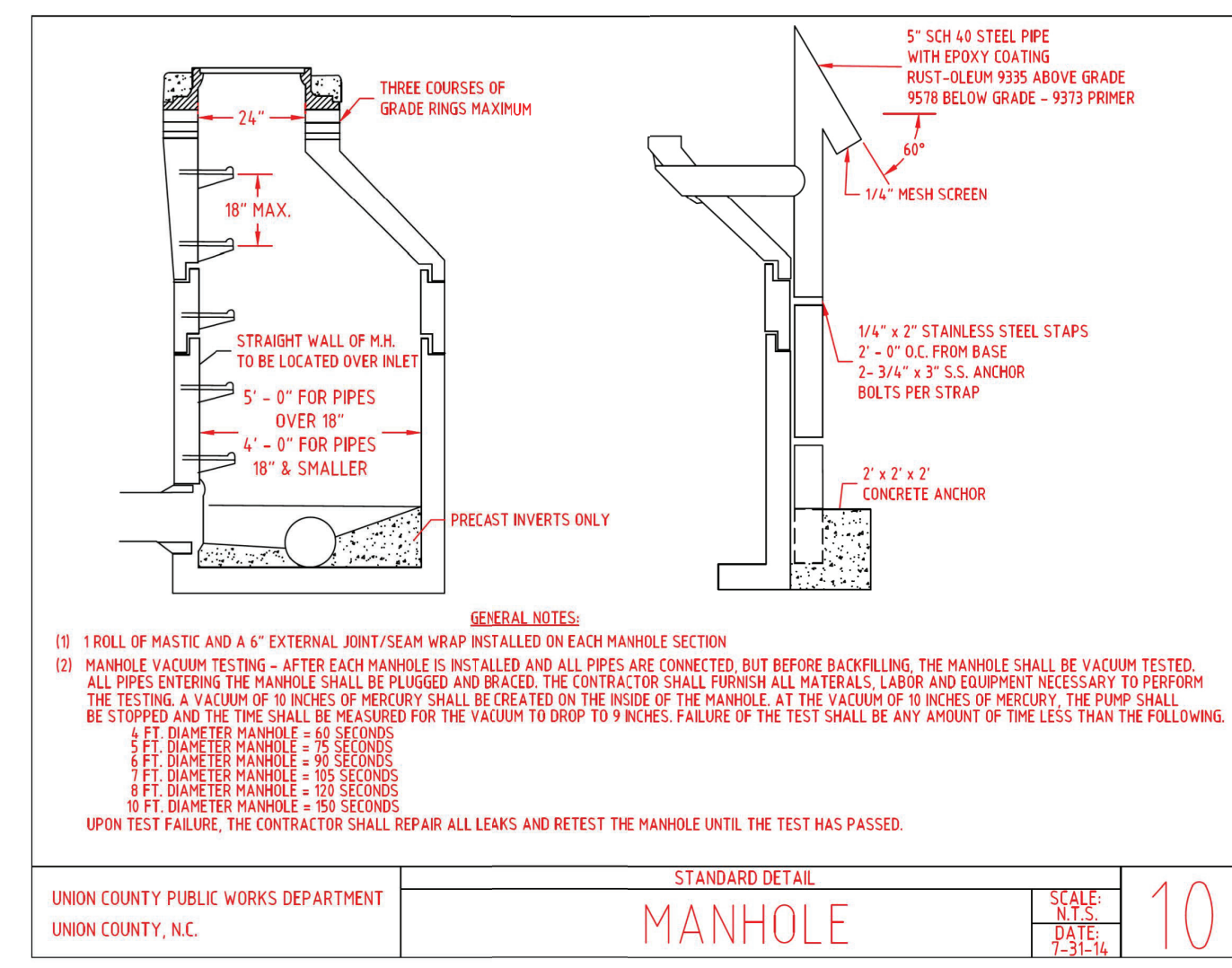

UNION COUNTY PUBLIC WORKS DEPARTMENT
UNION COUNTY, N.C. STANDARD DETAIL
MANHOLE SCALE: N.T.S. DATE: 7-5-14 **10**

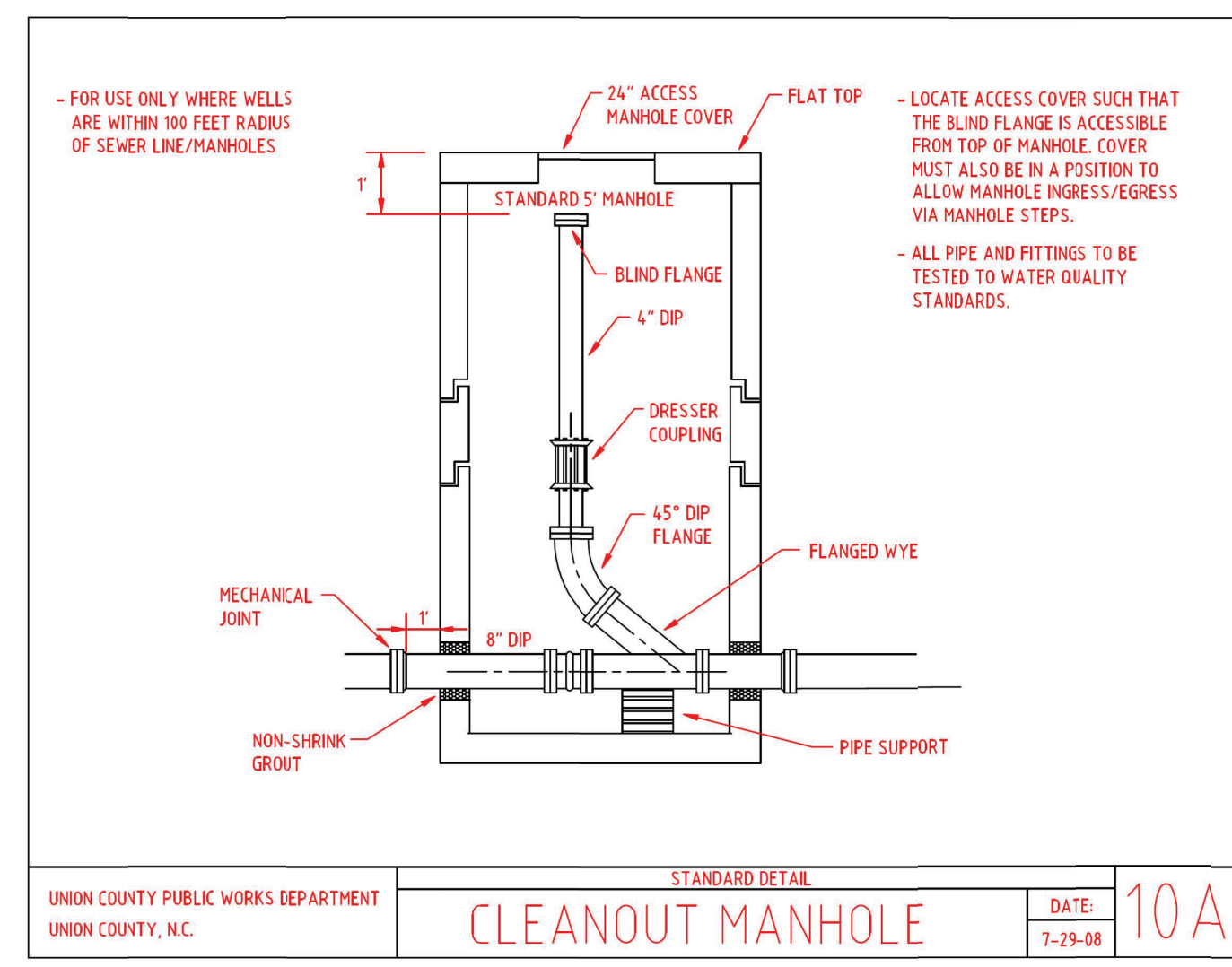

UNION COUNTY PUBLIC WORKS DEPARTMENT
UNION COUNTY, N.C. STANDARD DETAIL
CLEANOUT MANHOLE SCALE: N.T.S. DATE: 7-29-08 **10A**

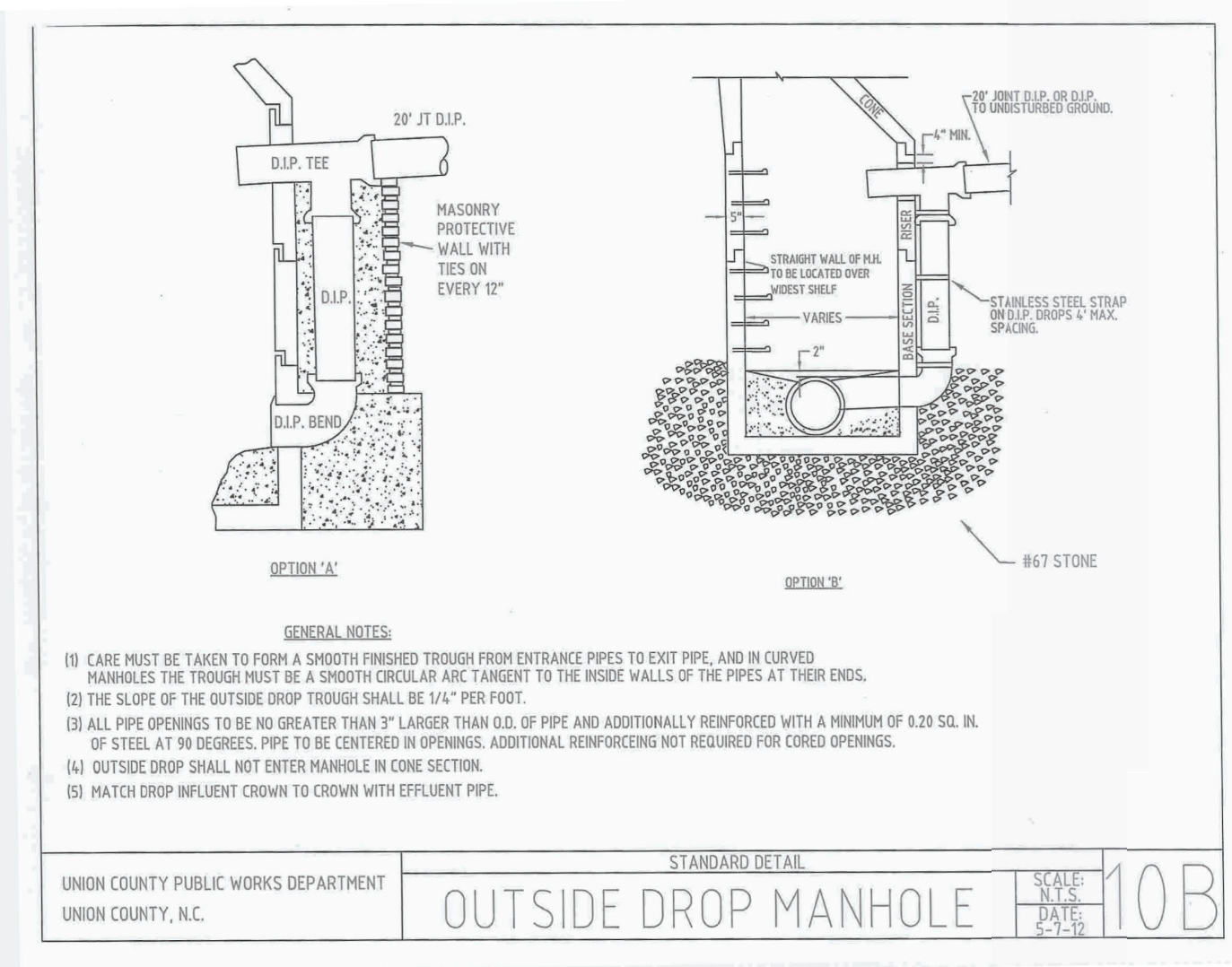

UNION COUNTY PUBLIC WORKS DEPARTMENT
UNION COUNTY, N.C. STANDARD DETAIL
OUTSIDE DROP MANHOLE SCALE: N.T.S. DATE: 9-1-14 **10B**

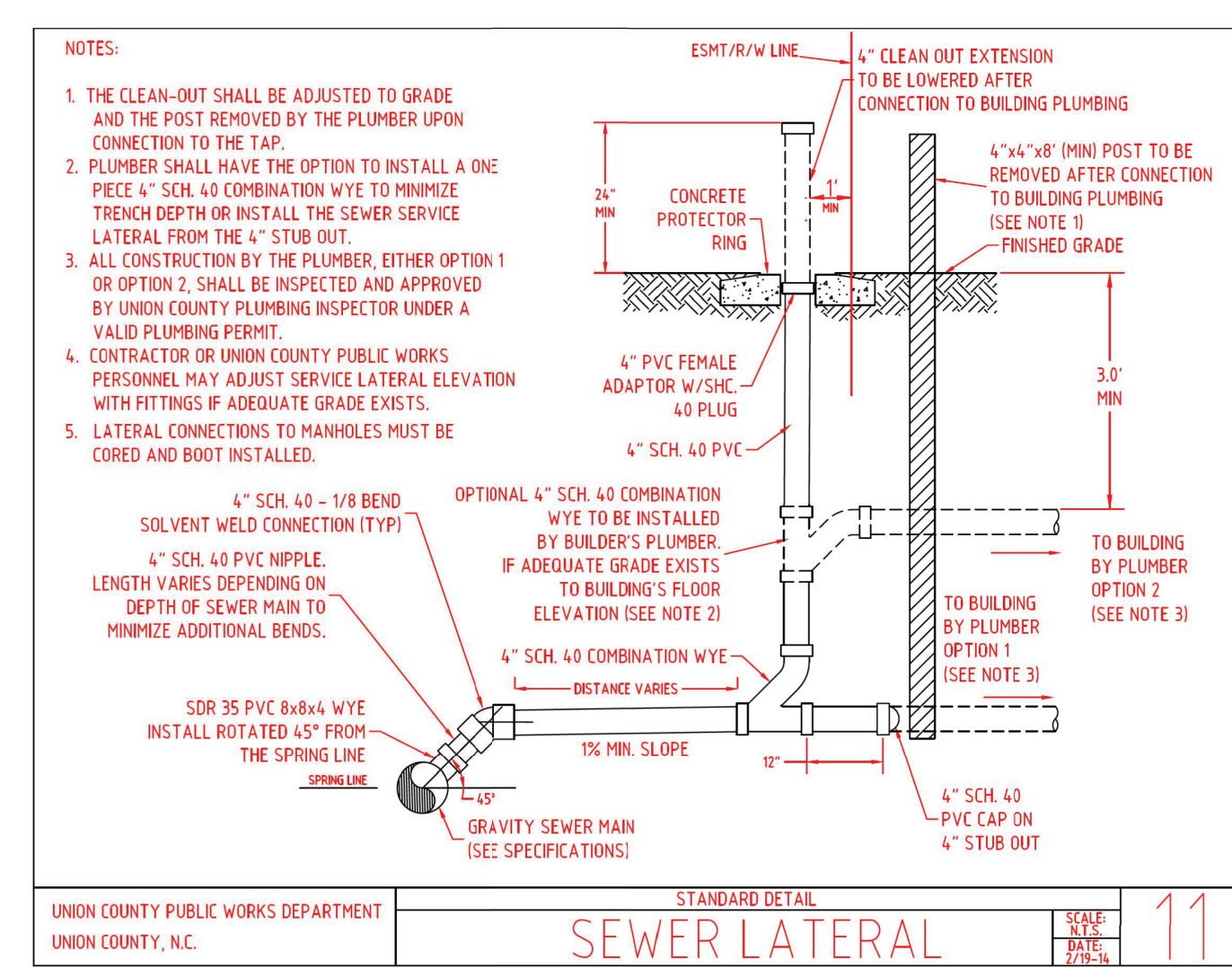

UNION COUNTY PUBLIC WORKS DEPARTMENT
UNION COUNTY, N.C. STANDARD DETAIL
SEWER LATERAL SCALE: N.T.S. DATE: 7-5-14 **11**

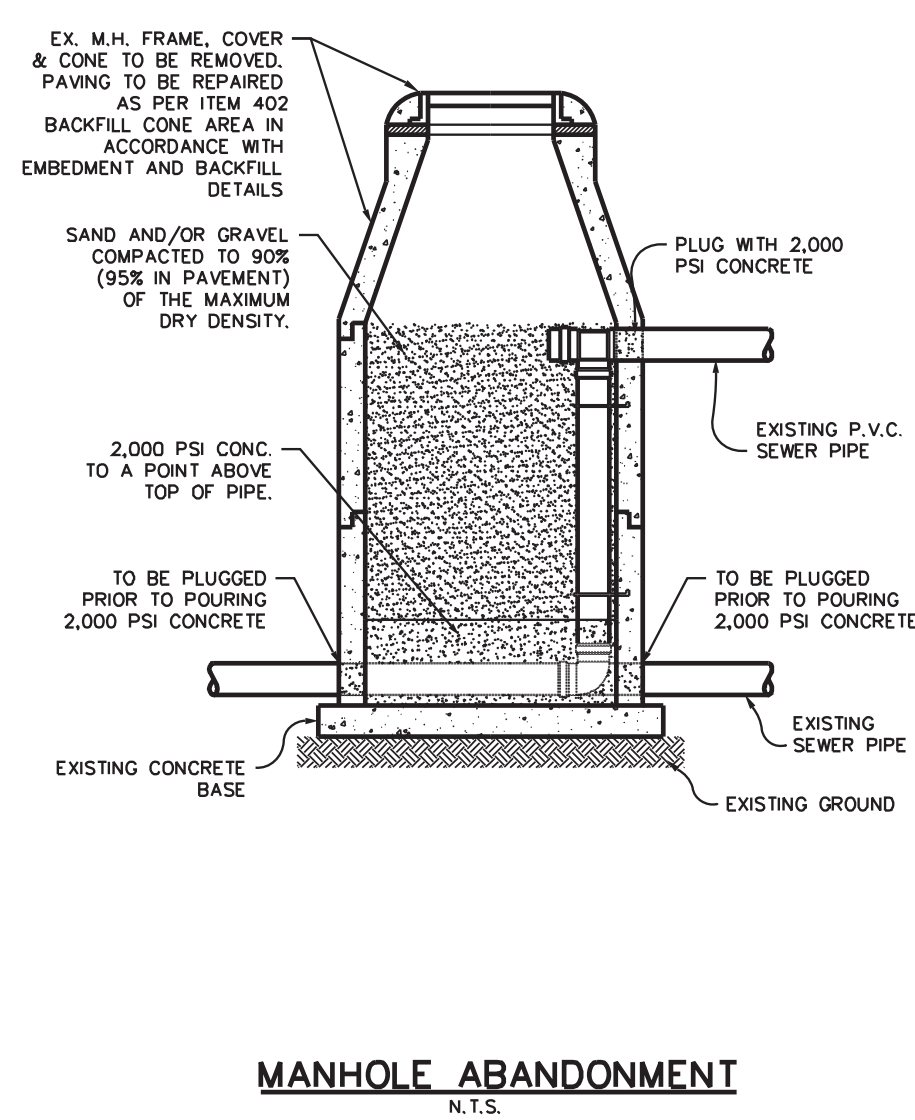

MANHOLE ABANDONMENT
N.T.S.

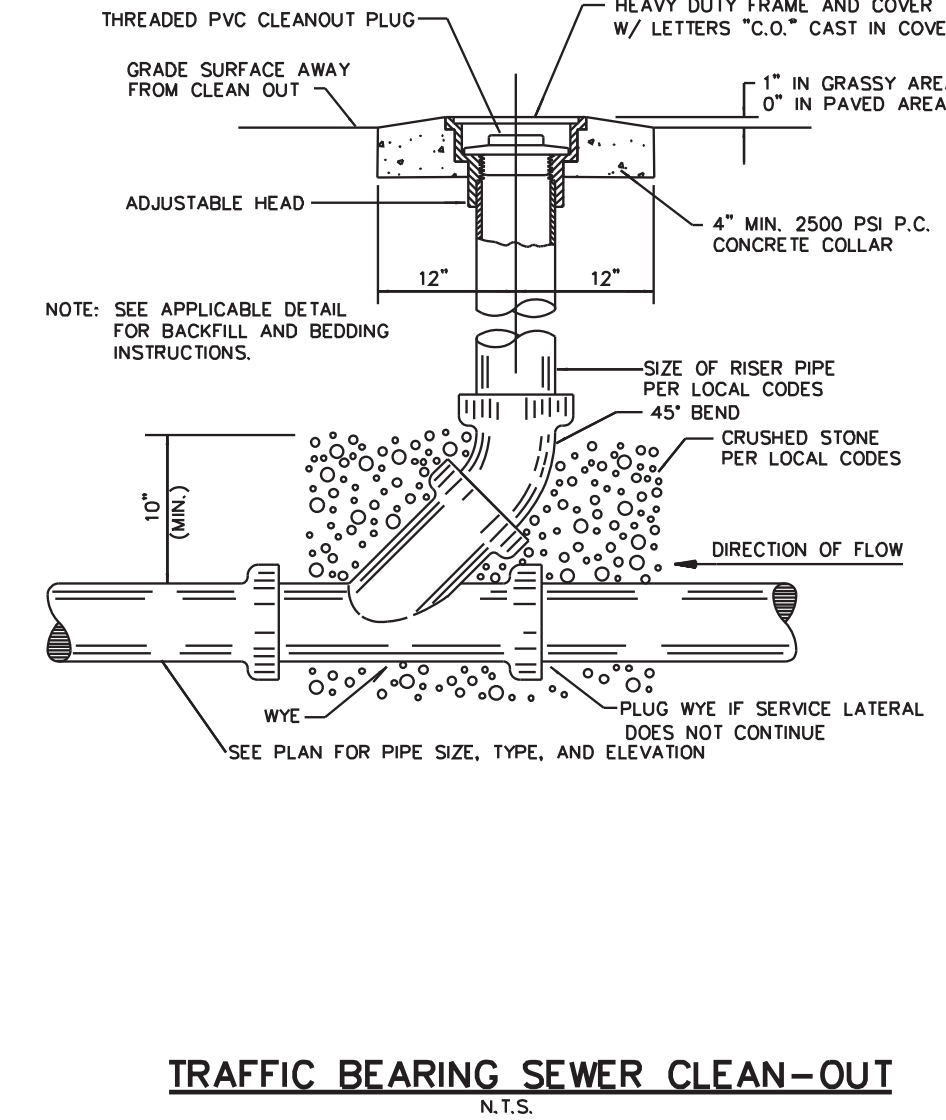

TRAFFIC BEARING SEWER CLEAN-OUT
N.T.S.

REVISIONS

1/17/2024

