

TRINITY ROAD
E. Chatham Street to Chapel Hill Road (NC-54)
Striping Improvements

NOTES, SCHEDULES AND DETAILS

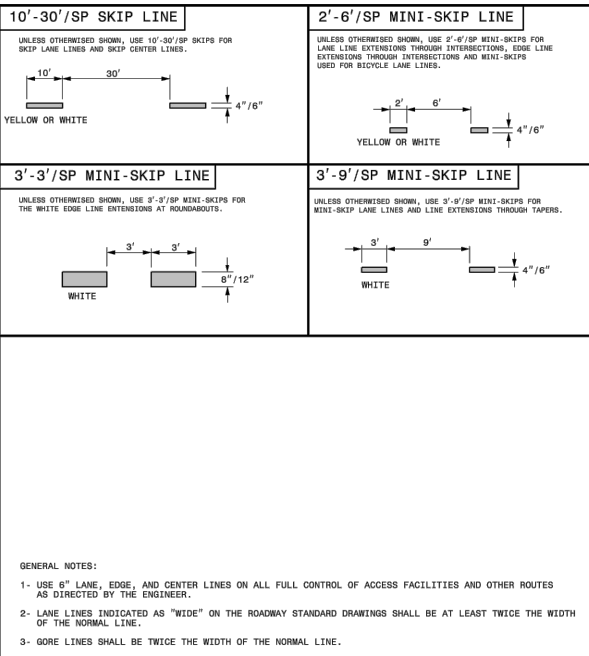
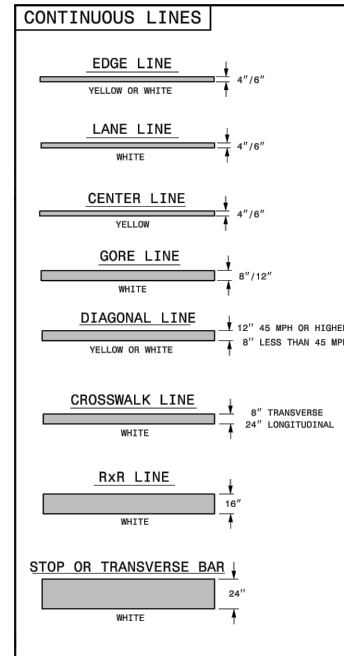

STATE OF NORTH CAROLINA
DEPT. OF TRANSPORTATION
DIVISION OF HIGHWAYS
RALEIGH, N.C.

ROADWAY STANDARD DRAWING FOR
PAVEMENT MARKINGS
LINE TYPES AND OFFSETS

SHEET 1 OF 2
1205.01

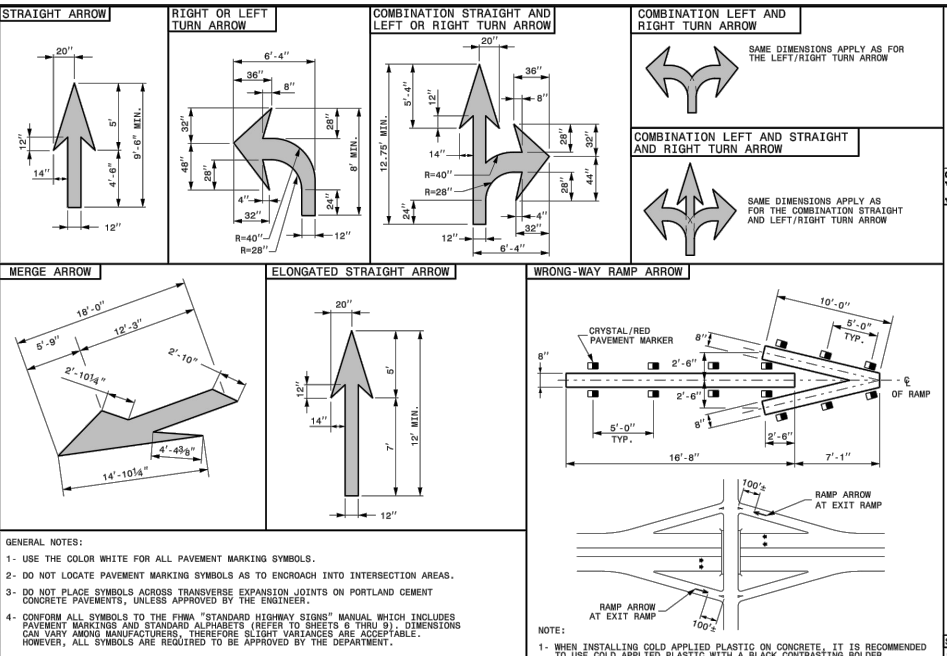

STATE OF NORTH CAROLINA
DEPT. OF TRANSPORTATION
DIVISION OF HIGHWAYS
RALEIGH, N.C.

ROADWAY STANDARD DRAWING FOR
PAVEMENT MARKINGS
SYMBOLS AND WORD MESSAGES

SHEET 1 OF 8
1205.08

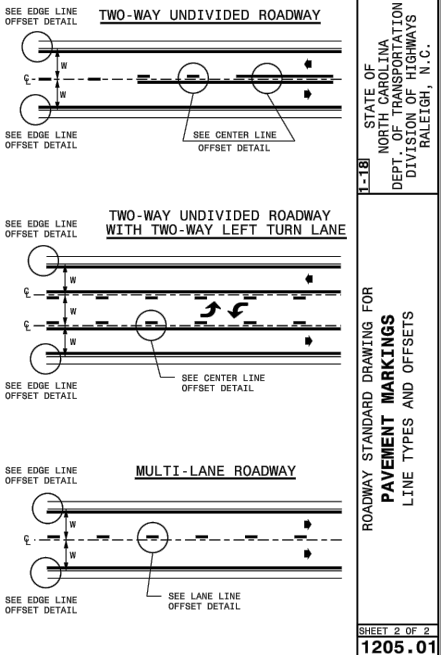
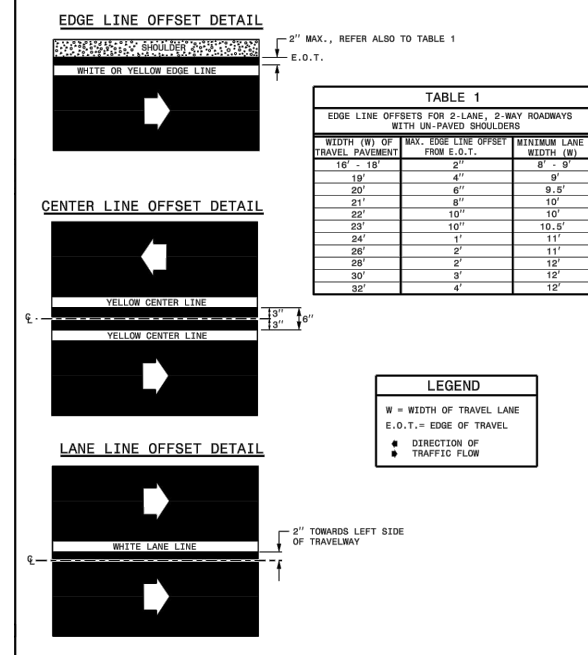

STATE OF NORTH CAROLINA
DEPT. OF TRANSPORTATION
DIVISION OF HIGHWAYS
RALEIGH, N.C.

ROADWAY STANDARD DRAWING FOR
PAVEMENT MARKINGS
LINE TYPES AND OFFSETS

SHEET 2 OF 2
1205.01

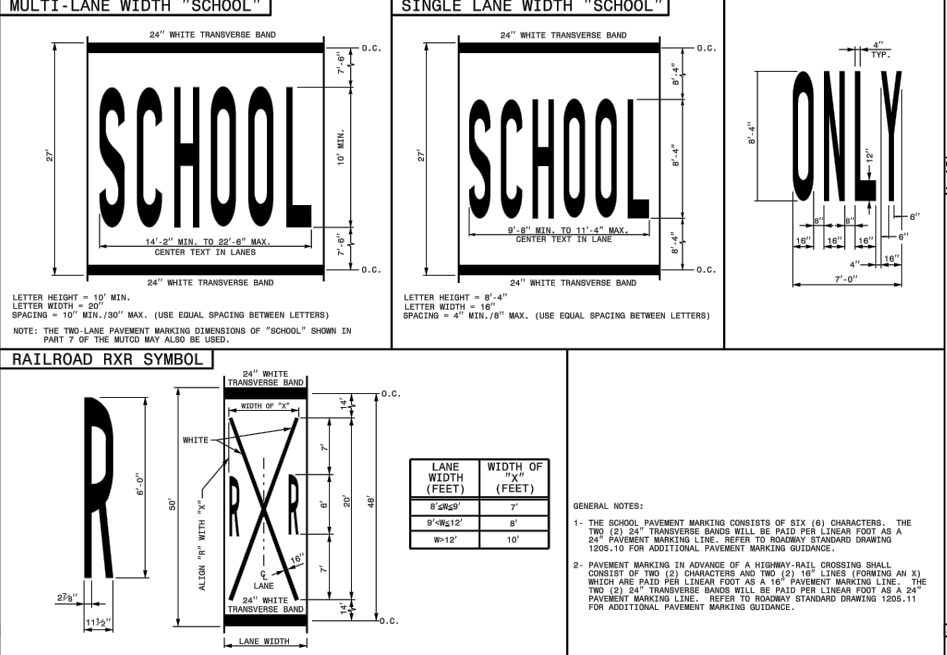

STATE OF NORTH CAROLINA
DEPT. OF TRANSPORTATION
DIVISION OF HIGHWAYS
RALEIGH, N.C.

ROADWAY STANDARD DRAWING FOR
PAVEMENT MARKINGS
SYMBOLS AND WORD MESSAGES

SHEET 4 OF 8
1205.08

- NOTES:
- CONTRACTOR TO COORDINATE WITH PROJECT MANAGER TO VERIFY ALIGNMENT OF ALL SIGNS, MARKING LINES AND SYMBOLS PRIOR TO PLACEMENT.
 - ROAD CENTERLINE AND STATIONING ARE BASED ON GEOGRAPHIC INFORMATION SYSTEM RECORDS AND ARE FOR RELATIVE REFERENCE ONLY.
 - NC DOT STANDARD DRAWINGS (PORTION) SHOWN FOR INFORMATION ONLY. ALL WORK SHALL COMPLY WITH NC DOT STANDARD DRAWINGS AND SPECIFICATIONS, LATEST EDITION, EXCEPT AS SPECIFICALLY MODIFIED IN THE CONTRACT DOCUMENTS.
 - ALL MARKING LINES SHALL BE THERMOPLASTIC IN ACCORDANCE WITH NC DOT STANDARDS, THICKNESS AS SHOWN.

STRIPING LEGEND & QUANTITY

ITEM DESCRIPTION	NC DOT STD DWG	QTY	UOM
4-INCH WIDE WHITE LINE, 90-MILS	1205.01	3244	LF
4-INCH WIDE YELLOW CENTERLINE, 90-MILS	1205.01	3661	LF
24-INCH WIDE WHITE LINE (STOP BAR / CROSSWALK), 90-MILS	1205.01, 1205.07	68	LF
RAILROAD "R" SYMBOL, 90-MILS	1205.08	2	EA
16-INCH WIDE WHITE LINE, 90-MILS	1205.01, 1205.08	43	LF
24-INCH WIDE WHITE LINE (RAILROAD), 90-MILS	1205.01, 1205.08	20	LF
3' - 9" MINI-SKIP LINE, 90-MILS	1205.01	150	LF
10' - 30' SKIP LINE, 90-MILS	1205.01	376	LF
TURN ARROW SYMBOL, 90 MILS	1205.08	2	EA
COMBINATION STRAIGHT AND TURN ARROW SYMBOL, 90 MILS	1205.08	2	EA