

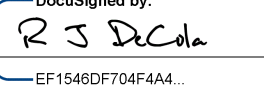

TIP NO.	SHEET NO.
U-5808	SIGN-1
APPROVED: 	
DATE: 10/9/2023	
SEAL	
	
DOCUMENT NOT CONSIDERED FINAL UNLESS ALL SIGNATURES COMPLETED	

**STATE OF NORTH CAROLINA  
DEPARTMENT OF TRANSPORTATION**

**SIGNING PLAN  
UNION COUNTY**

**LOCATION: SR 1362 (CHESTNUT LANE CONNECTOR) FROM SR 1367 (MATTHEWS INDIAN TRAIL ROAD) TO SR 1368 (GRIBBLE ROAD). CONSTRUCT ROAD ON NEW LOCATION. INTERSECTION OF US 74 AND EXISTING SR 1362 (CHESTNUT LANE CONNECTOR). CONSTRUCT INTERSECTION IMPROVEMENTS.**

**T.I.P.: U-5808**

**CONTRACT: C204842**

**INDEX**

SHEET NO.	DESCRIPTION
SIGN-1	TITLE SHEET
SIGN-1A	DETAIL 904D50 IN LIEU OF ROADWAY STD. DRAWING 904.50 SHEET 1 OF 2
SIGN-2	TYPE "E" & "F" SIGNS
SIGN-3-6	EXISTING & PROPOSED SIGNS

**GENERAL NOTES**

- . SIGNS FURNISHED BY STATE
- . CONFIRM IN WRITING AT LEAST 4 MONTHS IN ADVANCE, THE ACTUAL DATE THE DEPARTMENT FURNISHED SIGNS WILL BE REQUIRED.
- . ALL TYPE 'D' SIGNS SHALL BE MOUNTED ON TWO U-CHANNEL POSTS UNLESS OTHERWISE INDICATED ON THE PLANS.
- . IF REMOVAL OR RELOCATION OF SIGNS ON PRIVATE STREET (NON-STATE MAINTAINED) IS REQUIRED DUE TO CONSTRUCTION, THE CONTRACTOR SHALL INFORM THE ENGINEER. THE WORK WILL BE COMPLETED BY OTHERS.
- . WHEN NOT STATIONED OR DIMENSIONED ON PLANS, ALL 'E' AND 'F' SIGNS SHALL BE FIELD LOCATED BY THE ENGINEER
- . ALL EXISTING SIGNS ON "U" CHANNEL POST WITHIN THE PROJECT LIMITS SHALL BE REMOVED AND DISPOSED OF UNLESS OTHERWISE NOTED ON PLANS.
- . WHEN EXISTING SIGNS ARE REMOVED AND INSTALLED ON NEW SUPPORTS, THE RE-ERECTION SHALL IMMEDIATELY FOLLOW THE REMOVAL.
- . THE BACKGROUND FOR TYPE E & F SIGNS SHALL BE TYPE C REFLECTIVE SHEETING.
- . SEE ROADWAY PLANS FOR GUARD/GUIDE RAIL DETAILS.

**SUMMARY OF QUANTITIES**

ITEM NO.	DESC. NO.	SECT. NO.	ITEM DESCRIPTION	QUANTITY	UNIT
4072000000	903		SUPPORTS, 3-LB STEEL U-CHANNEL	800	L.F.
4102000000	904		SIGN ERECTION, TYPE E	60	EA.
4108000000	904		SIGN ERECTION, TYPE F	6	EA.
4116100000	904		SIGN ERECTION, RELOCATE TYPE D	1	EA.
4155000000	907		DISPOSAL OF SIGN SYSTEM, U-CHANNEL	11	EA.
4238000000	907		DISPOSAL OF SIGN, D, E, OR F	1	EA.

**ROADWAY STANDARD DRAWING**

THE FOLLOWING ROADWAY STANDARDS AS APPEAR IN "ROADWAY STANDARD DRAWINGS" - PROJECT SERVICES UNIT - N.C. DEPARTMENT OF TRANSPORTATION - RALEIGH, N.C., DATED JANUARY 2018 ARE APPLICABLE TO THIS PROJECT AND BY REFERENCE HEREBY ARE CONSIDERED A PART OF THESE PLANS:

STD. NO.	TITLE
904.10	ORIENTATION OF GROUND MOUNTED SIGNS
904.50	MOUNTING OF TYPE 'D', 'E' AND 'F' SIGNS ON 'U' CHANNEL POSTS
910.30	SIGNING SIGNALIZED AND UNSIGNALIZED SUPERSTREET
910.40	SINGLE/TWO LANE ROUNDABOUT WITH PEDESTRIAN

**NCDOT CONTACTS**

**YANNY MA, PE** DIVISION 10 DM-STIP PROJECT ENGINEER  
**KELVIN JORDAN** SIGNING & DELINEATION REGIONAL ENGINEER

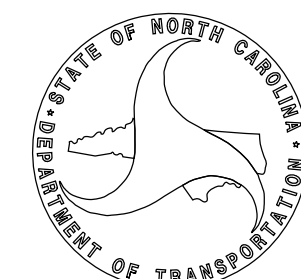

**PLAN PREPARED FOR NCDOT DIVISION 10 BY:**

**RICK DECOLA, PE** PROJECT ENGINEER  
**SURAJ SANGHANI, PE** PROJECT DESIGN ENGINEER

**Mead&Hunt**

111 E. Hargett Street, Suite 300  
 Raleigh, North Carolina 27601  
 919-714-8670 | meadhunt.com  
 NC License No. F-1235

TIP NO.	SHEET NO.
DocuSign by:	
APPROVED: <i>Matthew V. Springer</i>	
DATE: 6/23/2021	
SEAL	
	

STATE OF NORTH CAROLINA  
DEPT. OF TRANSPORTATION  
DIVISION OF HIGHWAYS  
RALEIGH, N.C.

6-21  
ENGLISH DETAIL DRAWING FOR  
MOUNTING OF  
TYPE 'D', 'E' AND 'F' SIGNS  
ON 'U' CHANNEL POSTS  
904D50

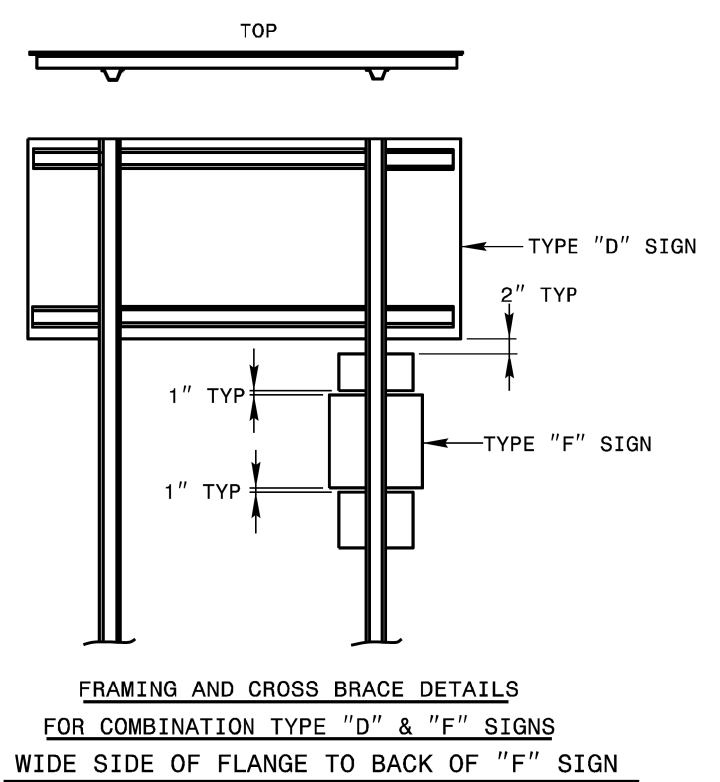
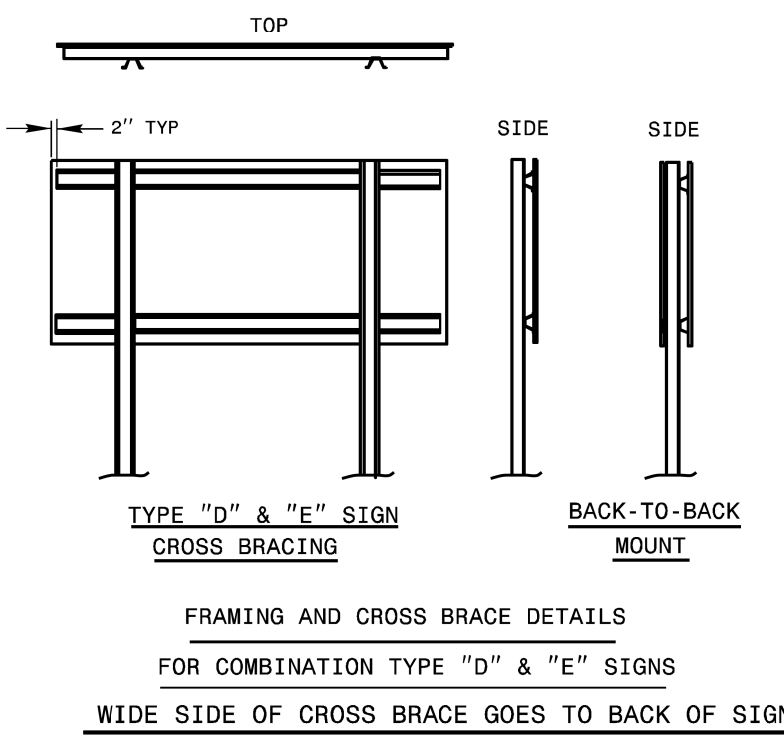
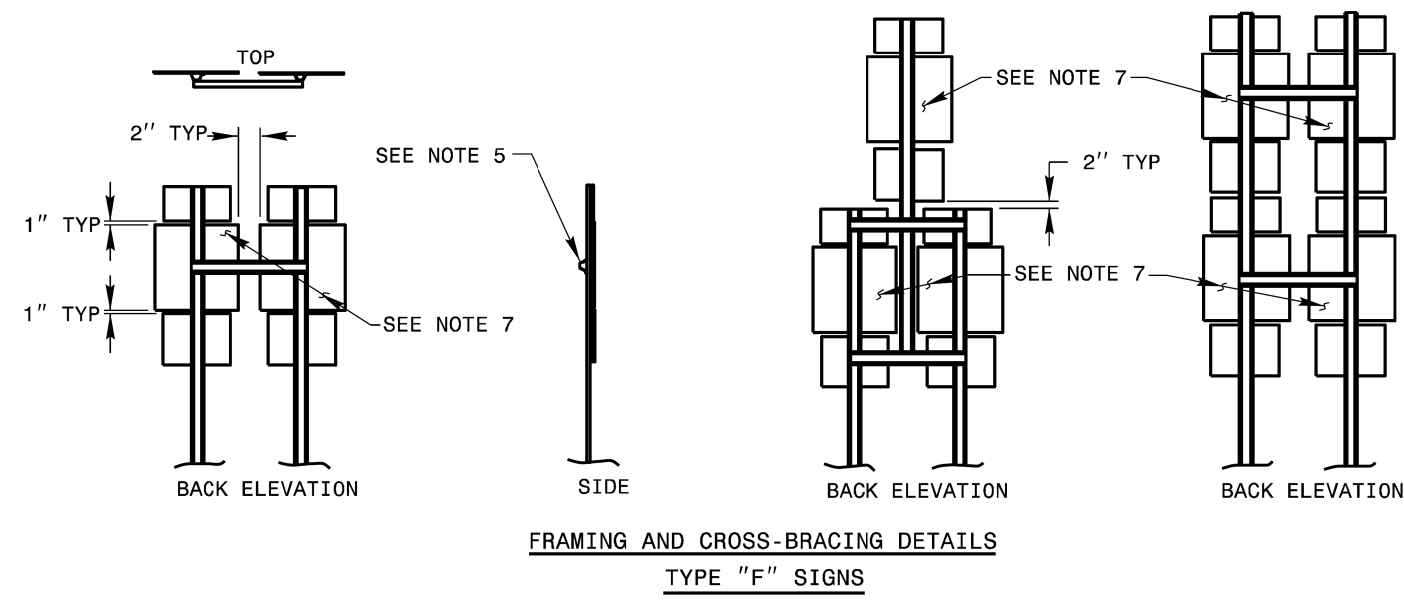
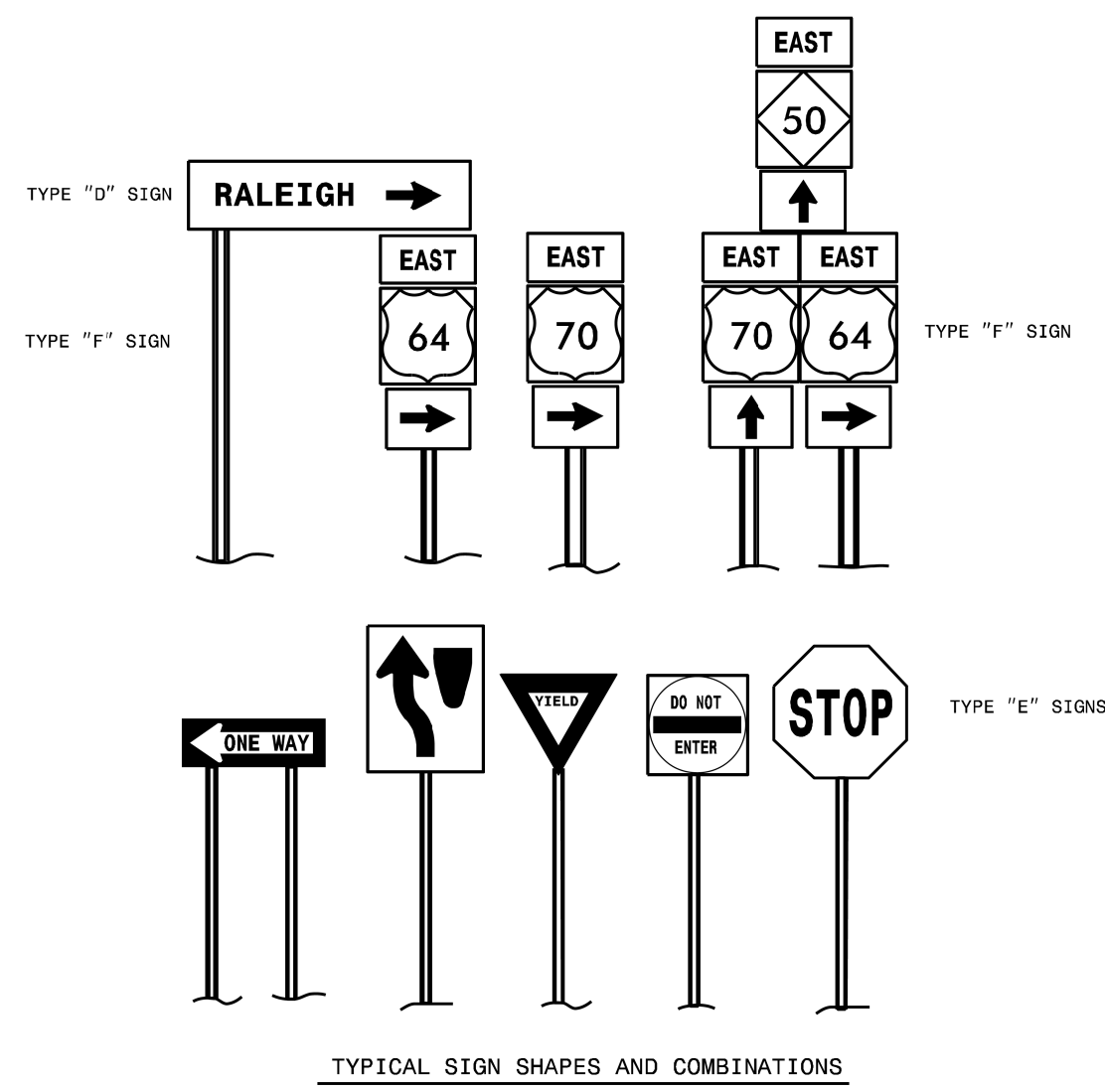
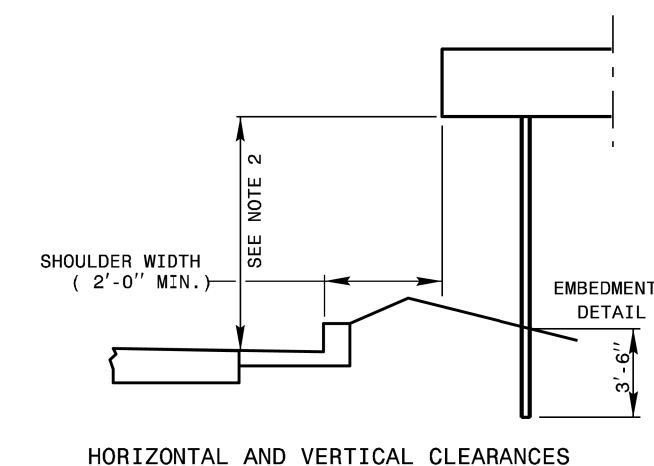
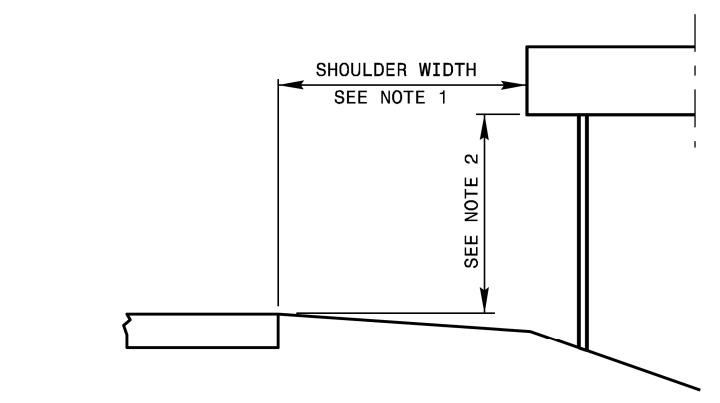

- NOTES:
- ERECT TYPE "D", "E", AND "F" SIGNS ON FREEWAYS WITH THE NEAR EDGE OF THE SIGN 20 FT. FROM THE TRAVEL LANE. ERECT ALL OTHER "D", "E", AND "F" SIGNS WITH THE NEAR EDGE OF THE SIGN AT THE EDGE OF THE SHOULDER BREAK (6 FT. MINIMUM CLEARANCE, 12 FT. DESIRABLE, FROM THE EDGE OF TRAVEL LANE), OR AS DIMENSIONED ON PLAN SHEETS.
  - ERECT TYPE "D", "E", AND "F" SIGNS WITH THE BOTTOM OF SIGN ASSEMBLY AT LEAST 7 FT. ABOVE THE EDGE OF THE TRAVEL LANE ON ROADS WITH 2 OR MORE LANES IN THE SAME DIRECTION AND AT LEAST 5 FT. ON OTHER ROUTES. THE VERTICAL CLEARANCE IS 7 FT. WHERE REQUIRED FOR PEDESTRIAN TRAFFIC AND/OR PARKED VEHICLES.
  - THE VERTICAL DIMENSION BETWEEN MOUNTING HOLE CENTERS ON ALL TYPES "D", "E", AND "F" SIGNS IS 30" MAXIMUM. THE VERTICAL AND HORIZONTAL DIMENSIONS BETWEEN MOUNTING HOLES IS TO THE WHOLE INCH. EACH SIGN PANEL HAS A MINIMUM OF 2 BOLTS PER SUPPORT.
  - ATTACH SIGN W/ 5/16" HEX HEAD BOLT, NYLON WASHER, SHIM, FLAT WASHER, LOCK WASHER, HEX NUT. NO BUCKLING OF THE SIGN WILL BE PERMITTED. SEE ASSEMBLY DETAIL SHEET# 2 OF 904.50.
  - FURNISH AND INSTALL CROSS-BRACING AS SHOWN IN DETAIL. PAINT ENDS OF CROSS BRACES W/ APPROVED. ZINC PAINT.
  - INSTALL POST AND CROSS-BRACING WITH THE WIDE SIDE OF THE FLANGE TOWARD THE BACK OF SIGN(S) FOR COMBINATION TYPE "D" AND "F" SIGNS.
  - THE SHIELD HEIGHTS IN THESE ASSEMBLIES CAN NOT BE LARGER THAN 24".
  - IF SIGN ASSEMBLIES REQUIRE MORE THAN TWO U-CHANNEL SUPPORTS, THE SUPPORTS SHALL BE PLACED A MINIMUM OF 4 FT. BETWEEN POSTS. NO MORE THAN TWO POSTS SHALL FALL WITHIN 7 FT. PATH, OR THE SIGN ASSEMBLY MUST BE PLACED BEHIND BARRIER PROTECTION.

STATE OF NORTH CAROLINA  
DEPT. OF TRANSPORTATION  
DIVISION OF HIGHWAYS  
RALEIGH, N.C.

6-21  
ENGLISH DETAIL DRAWING FOR  
MOUNTING OF  
TYPE 'D', 'E' AND 'F' SIGNS  
ON 'U' CHANNEL POSTS  
904D50

REVISED SIGNING  
ROADWAY STANDARD DRAWING

09/02/23  
 S:\S&D\Standards Group\Drawings\Standards and Drawings\Drawings\2018 Standard Dwg\Division 9 Final\0904.50\_sgn\_sht01\_uchannelpost\_6-21.dgn  
 User: j184rjd

6/18/2021  
 S:\S&D\Standards Group\Drawings\Standards and Drawings\Drawings\2018 Standard Dwg\Division 9 Final\0904.50\_sgn\_sht01\_uchannelpost\_6-21.dgn  
 User: j184rjd

6-14-21

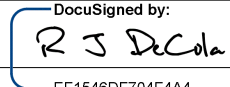
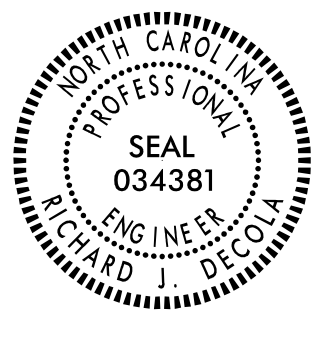

TIP NO. <b>U-5808</b>	SHEET NO. <b>SIGN-2</b>
APPROVED:  EF1546D704F444	
DATE: 10/9/2023	
SEAL 	
<b>DOCUMENT NOT CONSIDERED FINAL UNLESS ALL SIGNATURES COMPLETED</b>	
<b>Mead&amp;Hunt</b> <small>111 E. Hargett Street, Suite 300 Raleigh, North Carolina 27601 919-714-8870   meadandhunt.com NC License No. F-1235</small>	

401 QUANTITY REQ'D 1 \_

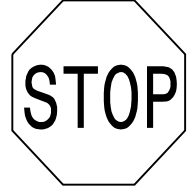

36" X 36"  
R1-1

ONE "U" POST PER SIGN

402 QUANTITY REQ'D 6 \_

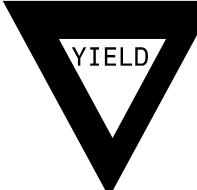

36" X 36" X 36"  
R1-2

ONE "U" POST PER SIGN

403 QUANTITY REQ'D 8 \_



12" X 36"  
R1-6

ONE "U" POST PER TWO SIGNS

404 QUANTITY REQ'D 3 \_



30" X 36"  
R2-1

ONE "U" POST PER SIGN

405 QUANTITY REQ'D 2 \_

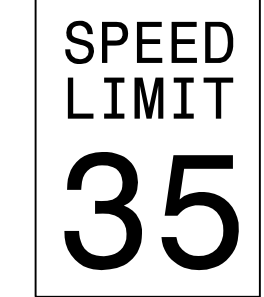

24" X 30"  
R2-1

ONE "U" POST PER SIGN

406 QUANTITY REQ'D 2 \_

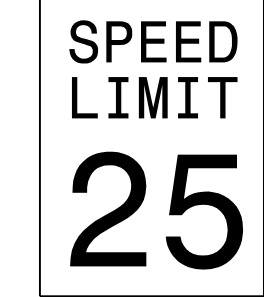

30" X 36"  
R2-1

ONE "U" POST PER SIGN

407 QUANTITY REQ'D 2 \_



54" X 18"  
R6-1 (R)

TWO "U" POSTS PER SIGN

408 QUANTITY REQ'D 1 \_



54" X 18"  
R6-1 (L)

TWO "U" POSTS PER SIGN

409 QUANTITY REQ'D 4 \_

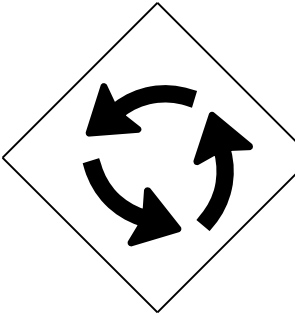

30" X 30"  
W2-6

ONE "U" POST PER SIGN

410 QUANTITY REQ'D 4 \_

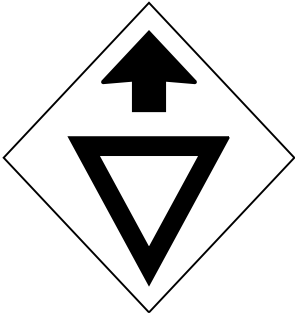

30" X 30"  
W3-2

ONE "U" POST PER SIGN

411 QUANTITY REQ'D 3 \_



48" X 24"  
R6-4a

TWO "U" POSTS PER SIGN

412 QUANTITY REQ'D 1 \_



30" X 24"  
R6-4

ONE "U" POST PER SIGN

413 QUANTITY REQ'D 8 \_

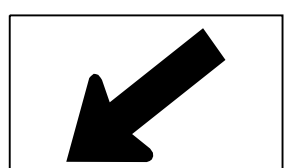

24" X 12"  
W16-7P

MOUNT BELOW SIGN 414  
IN 8 INSTALLATIONS

ONE "U" POST PER SIGN

414 QUANTITY REQ'D 8 \_



36" X 36"  
W11-2

ONE "U" POST PER SIGN

415 QUANTITY REQ'D 1 \_

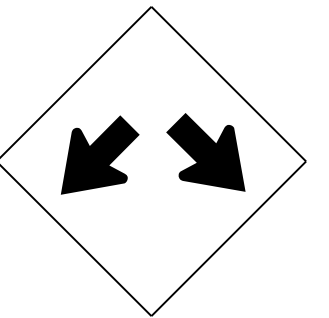

36" X 36"  
W12-1

ONE "U" POST PER SIGN

416 QUANTITY REQ'D 1 \_



36" X 36"  
R3-8

ONE "U" POST PER SIGN

417 QUANTITY REQ'D 1 \_



36" X 36"  
R3-8

ONE "U" POST PER SIGN

418 QUANTITY REQ'D 2 \_



36" X 36"  
R3-7R

ONE "U" POST PER SIGN

419 QUANTITY REQ'D 1 \_



30" X 30"  
R5-1

ONE "U" POST PER SIGN

420 QUANTITY REQ'D 1 \_

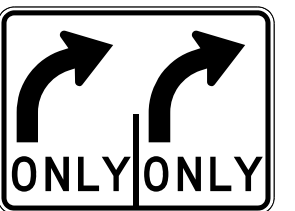

36" X 36"  
R3-8

ONE "U" POST PER SIGN

SIGN NUMB: TYPE: F Ground QUANTITY: 1	BACKG. COLOR: White COPY COLOR: Black	DESIGN BY: PROJECT ID:	CHK BY: DIV:	STD #: DATE:	N. C. DEPARTMENT OF TRANSPORTATION DIVISION OF HIGHWAYS TRANSPORTATION MOBILITY & SAFETY SIGNING & DELINEATION UNIT
---	--	---------------------------	-----------------	-----------------	--

SIGN WIDTH: 1'-9"  
HEIGHT: 1'-9"  
TOTAL AREA: 3.1 Sq.Ft.

SYMBOL	X	Y	WID	HT
u arrow	3.7	3.5	12.7	13.9

MAT'L: 0.063" ALUMINUM  
BORDER TYPE: RECESSED  
RECESS: 0.38"  
WIDTH: 0.63"  
RADI: 1.5"  
NO. Z BARS:  
LENGTH:

NOTES:  
1. Legend and border shall be direct applied  
Non-reflective sheeting.  
2. Background shall be Grade C reflective sheeting.

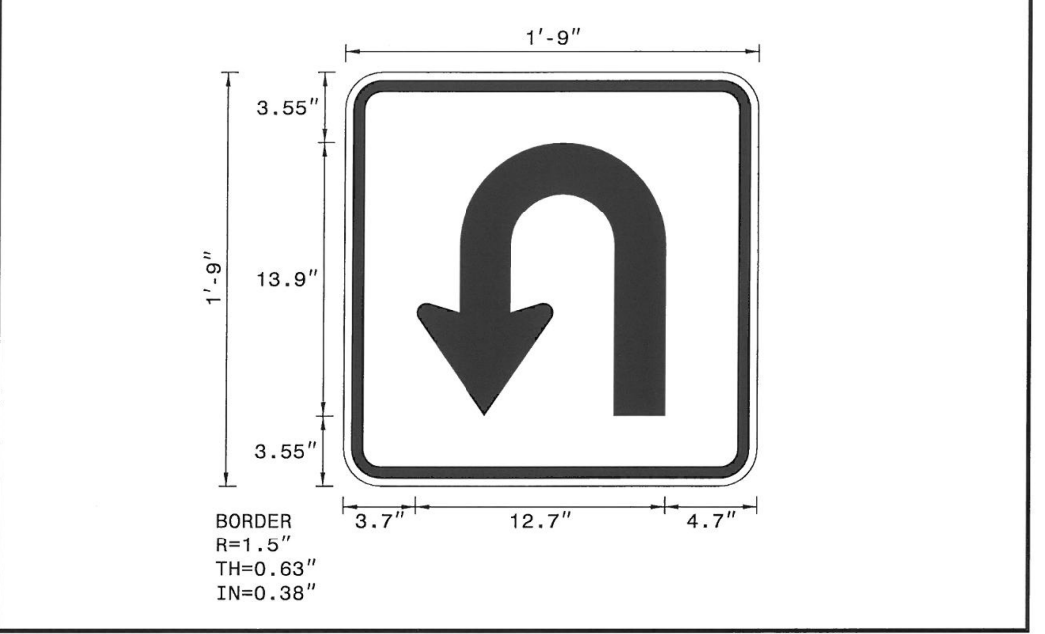

Arrow Details

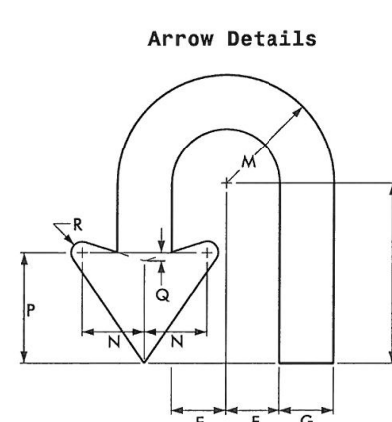

ARROW DIMENSIONS (INCHES)	F	G	H	M	N	P	Q	R
	2.625	2.625	8.659	5.25	3	5.25	0.375	0.5

Spacing Factor is 1 unless specified otherwise  
FILENAME: 05ENG

501 QUANTITY REQ'D 2 \_



24" X 12"  
M3-2



24" X 24"  
M1-4

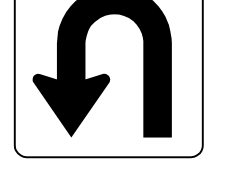

21" X 21"  
RNC3-26

ONE "U" POST PER SIGN

502 QUANTITY REQ'D 3 \_



24" X 12"  
M3-4



24" X 24"  
M1-4

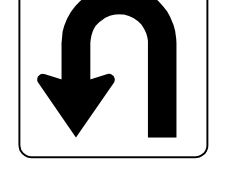

21" X 21"  
RNC3-26

ONE "U" POST PER SIGN

503 QUANTITY REQ'D 1 \_



24" X 12"  
M4-5



2 - 24" X 12"  
M3-4, M3-2



2 - 24" X 24"  
M1-4



2 - 24" X 18"  
M5-4, M5-6

TWO "U" POSTS PER SIGN

**TYPE "E" & "F" SIGNS**

10/09/23  
R:\Users\jfr\My Documents\Signing\CADD\Signing Layout Plans\U5808\_Sgn\_Sgn\_2.dgn  
User: jfr

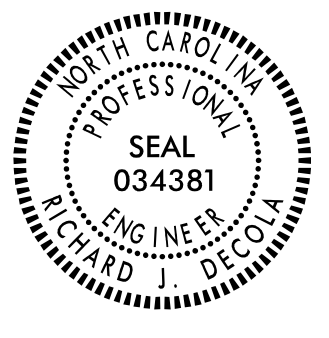

TIP NO. U-5808	SHEET NO. SIGN-3
APPROVED: <i>R S Decala</i> EF15460704F444	
DATE: 10/9/2023	
SEAL 	
DOCUMENT NOT CONSIDERED FINAL UNLESS ALL SIGNATURES COMPLETED	
Mead&Hunt <small>111 E. Hargett Street, Suite 300 Raleigh, North Carolina 27601 919-714-8870   meadandhunt.com NC License No. F-1235</small>	

### PROJECT NOTES

- 1 DISPOSAL OF SIGN SYSTEM, U-CHANNEL
- 3 SIGN ERECTION, TYPE D, E AND F

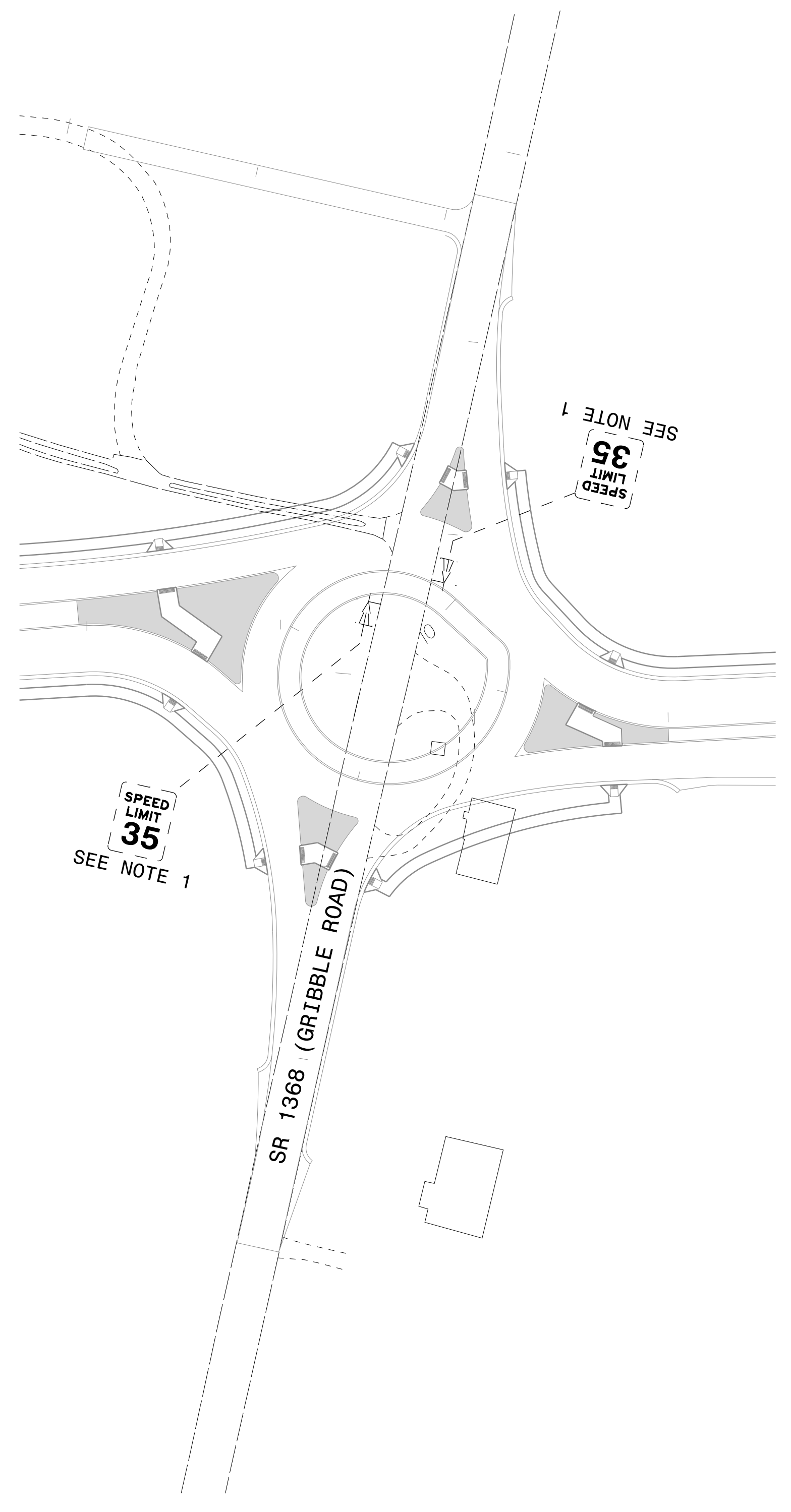

EXISTING SIGNS

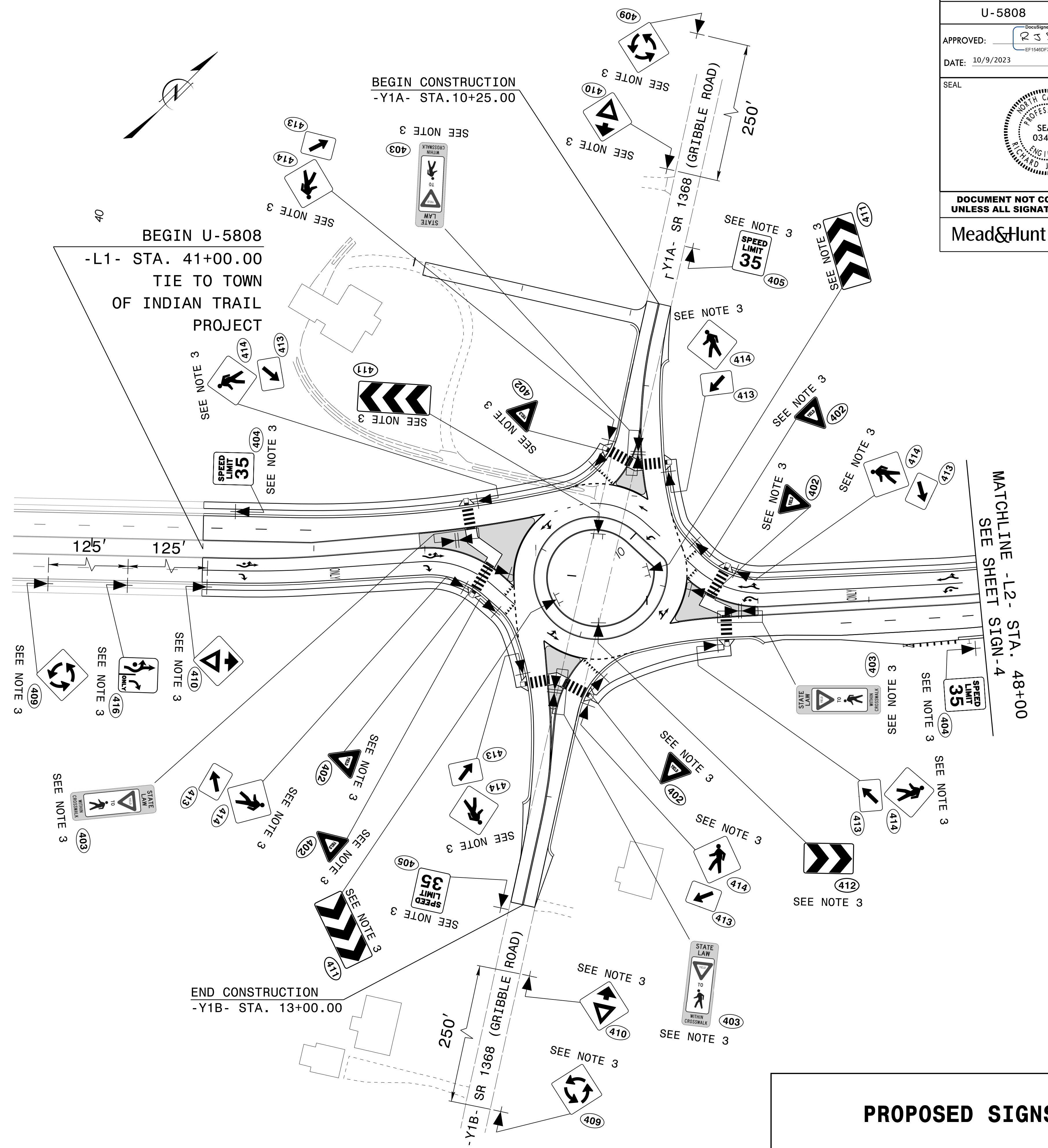

PROPOSED SIGNS

10/09/23  
R:\Users\rlf\OneDrive\Working\CADD\Signing Layout Plans\U5808\_Sgn\_SGN\_3.dgn  
User:rlf







