

NOTES

STIRRUPS IN CAP MAY BE SHIFTED AS NECESSARY TO CLEAR ANCHOR BOLTS.

★ INVERT ALTERNATE STIRRUPS.

FOR ADDITIONAL REINFORCING STEEL IN PP 18 X 0.50 GALVANIZED STEEL PILES, SEE SHEET 3 OF 3.

GALVANIZE THE TOP OF EACH INTERIOR BENT PILE A MINIMUM OF 39 FEET. GALVANIZE IN ACCORDANCE WITH SECTION 1076 OF THE STANDARD SPECIFICATIONS.

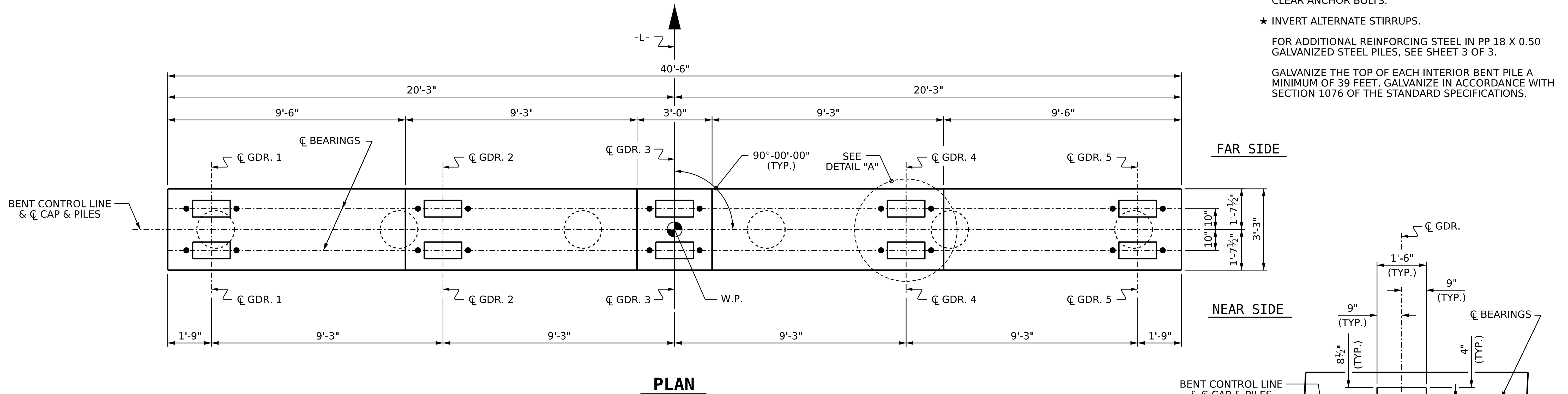

PLAN

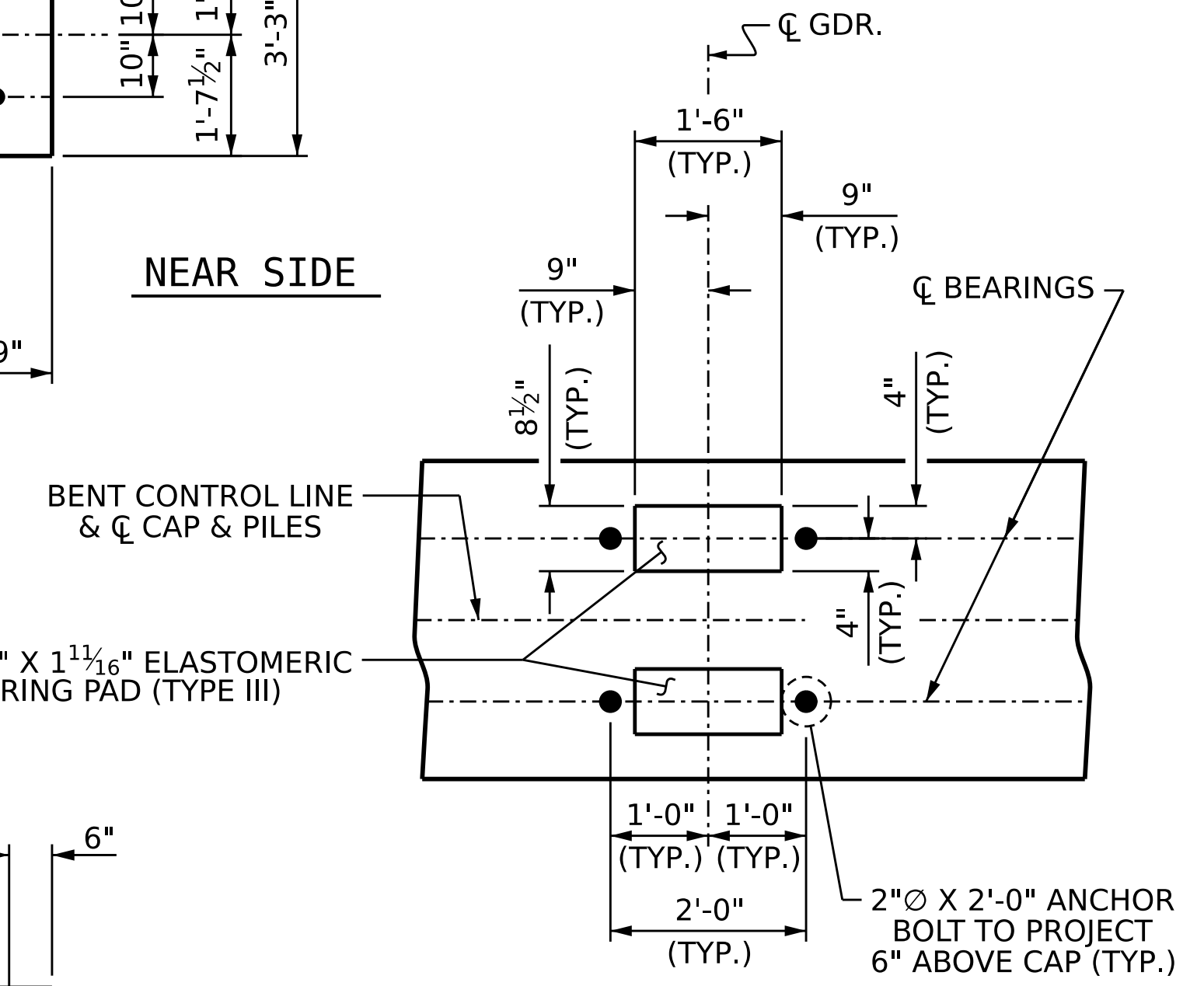

DETAIL "A"
(TYP. EA. GDR.)

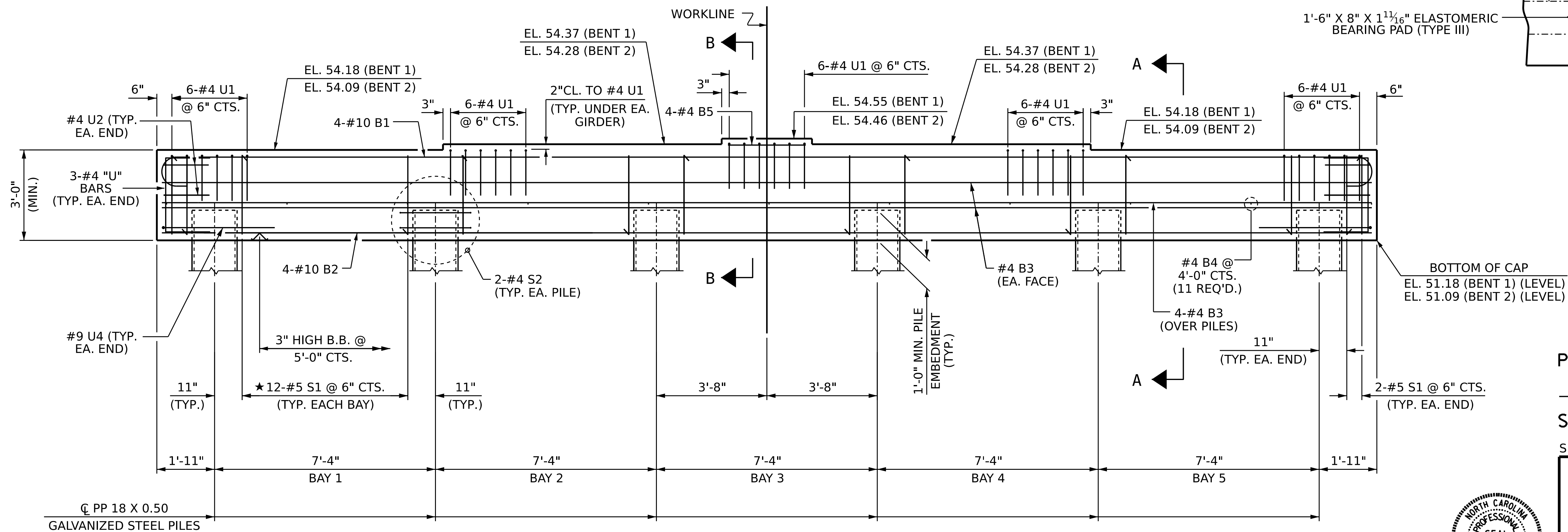

ELEVATION

FOR SECTION A-A & B-B, SEE SHEET 2 OF 3

PROJECT NO. **BR-0046**
SAMPSON COUNTY
 STATION: **24+30.00 -L-**

SHEET 1 OF 3

STATE OF NORTH CAROLINA
 DEPARTMENT OF TRANSPORTATION
 RALEIGH

SUBSTRUCTURE
BENTS 1 & 2



Designed by:
 P. Corey Newton
 10/09/2023

DRAWN BY : P. D. BRYANT DATE : 8/31/22
 CHECKED BY : D. R. SHACKELFORD DATE : 8/31/22
 DESIGN ENGINEER OF RECORD: P. D. BRYANT DATE : 9/13/23

10/9/2023
 R:\Structures\Plans\401.047_BR-0046_SMU.B12.S-23.810022.dgn
 pknewton

DOCUMENT NOT CONSIDERED
 FINAL UNLESS ALL
 SIGNATURES COMPLETED

REVISIONS						SHEET NO.
NO.	BY:	DATE:	NO.	BY:	DATE:	S-23
1			3			TOTAL SHEETS
2			4			31