

\* NOTE: SEE STD. DWG. 846.01  
FOR GENERAL NOTES

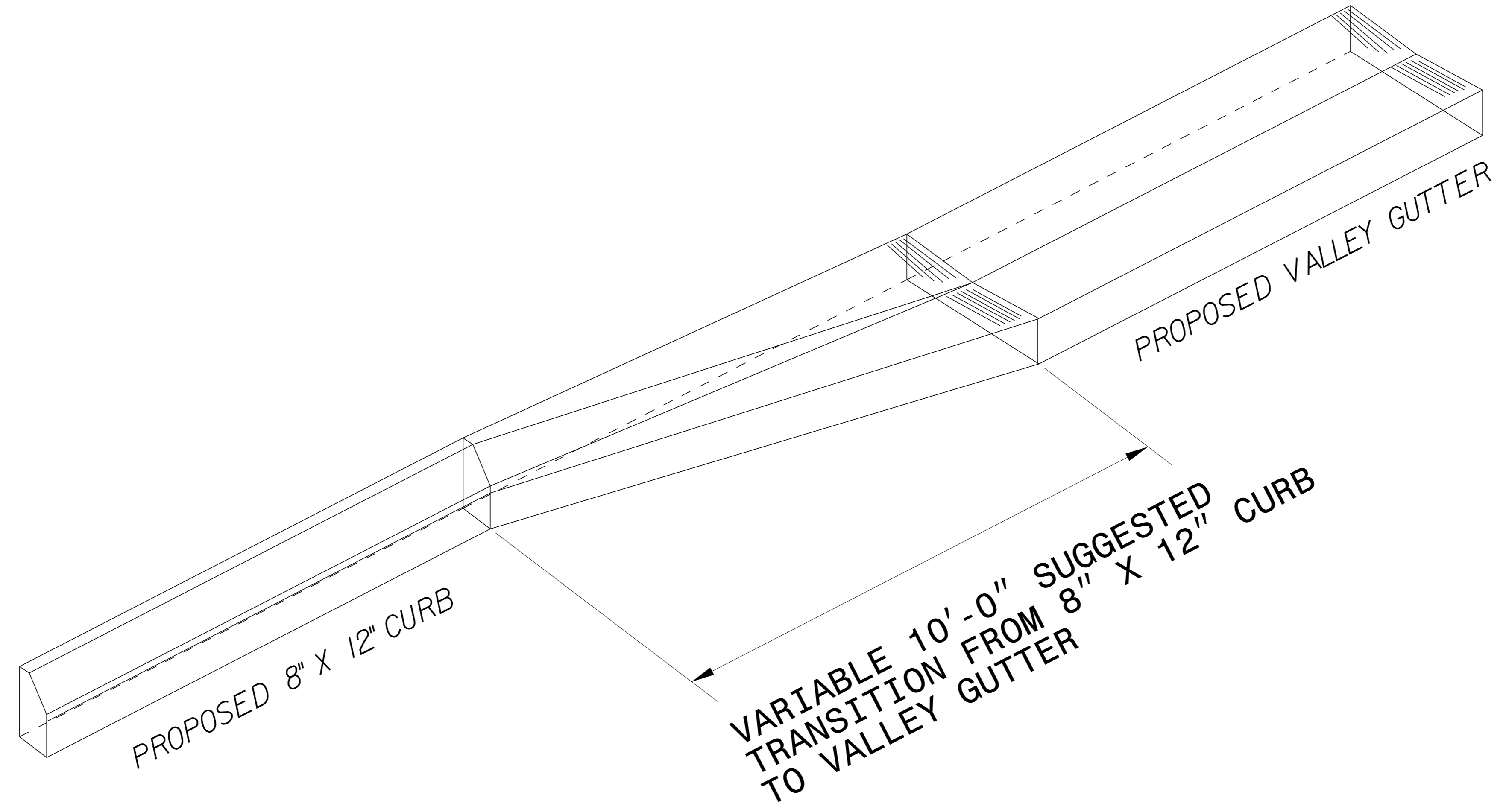

TRANSITION FROM 8" X 12"  
CURB TO VALLEY GUTTER