

SEE TMP-19A FOR SECTION DETAIL

PROJ. REFERENCE NO.	SHEET NO.
B-3186 / B-5898	TMP-19

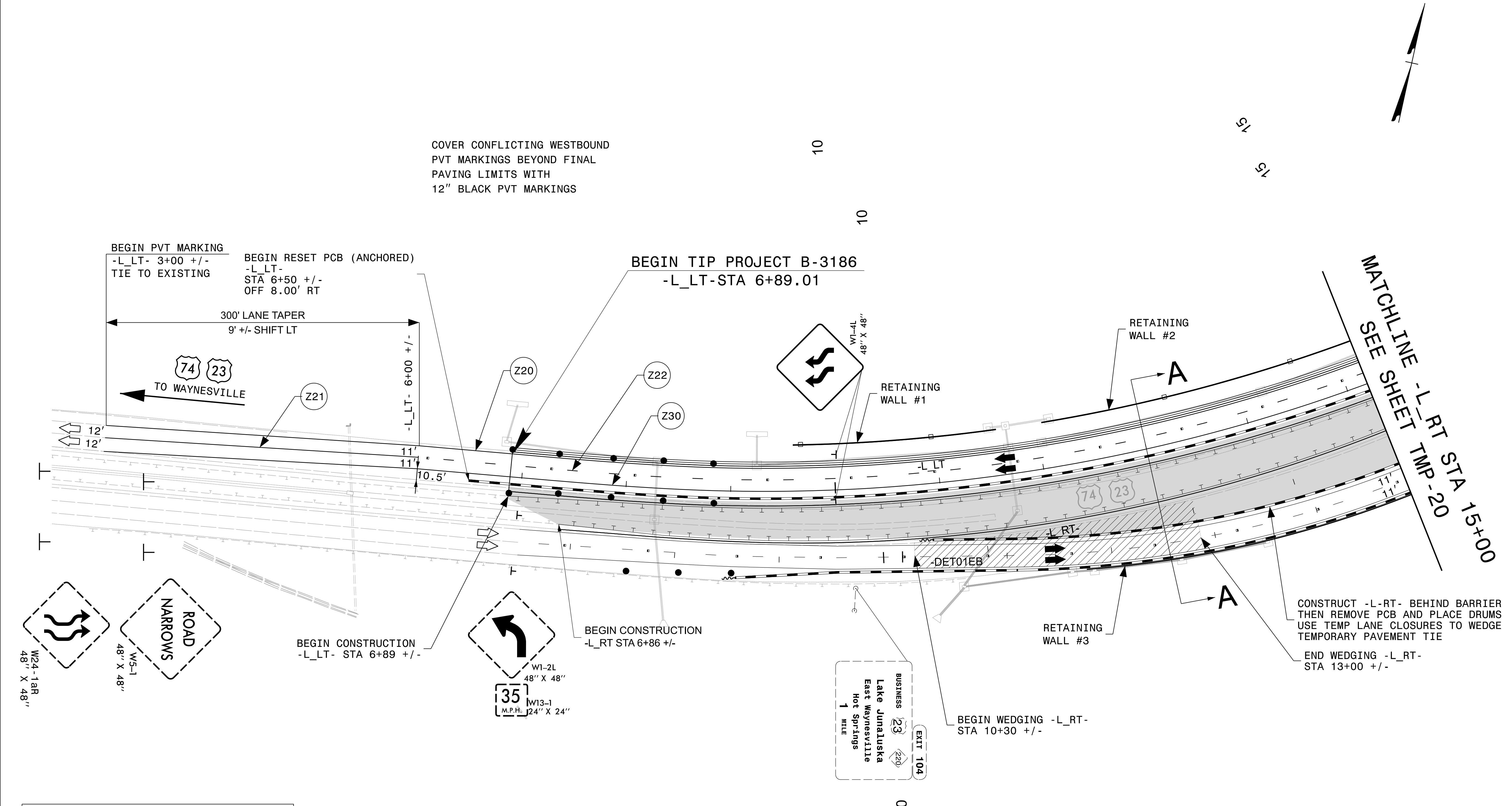

COVER CONFLICTING WESTBOUND
PVT MARKINGS BEYOND FINAL
PAVING LIMITS WITH
12" BLACK PVT MARKINGS

BEGIN PVT MARKING
-L_LT- 3+00 +/-
TIE TO EXISTING

BEGIN RESET PCB (ANCHORED)
-L_LT-
STA 6+50 +/-
OFF 8.00' RT

300' LANE TAPER
9' +/- SHIFT LT

BEGIN TIP PROJECT B-3186
-L_LT- STA 6+89.01

MATCHLINE -L_RT- STA 15+00
SEE SHEET TMP-20

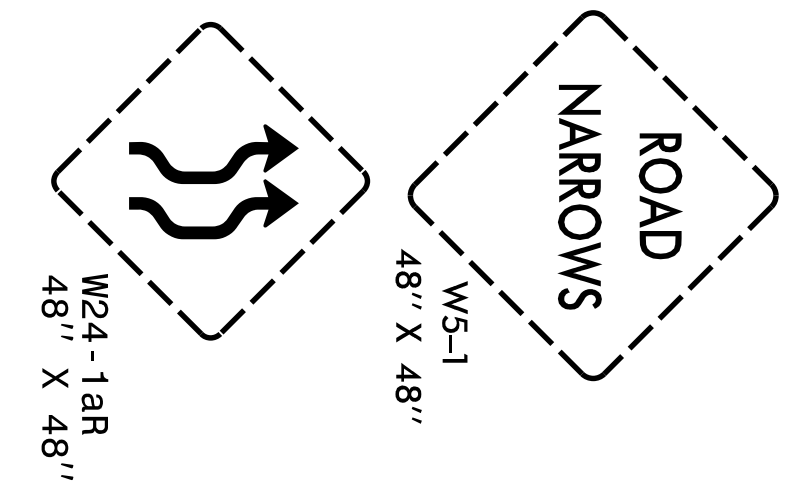

BEGIN CONSTRUCTION
-L_LT- STA 6+89 +/-

BEGIN CONSTRUCTION
-L_RT- STA 6+86 +/-

W1-2L
48" X 48"

W13-1
24" X 24"

EXIT 104
BUSINESS 23
Lake Junaluska
East Waynesville
Hot Springs
1 MILE

BEGIN WEDGING -L_RT-
STA 10+30 +/-

CONSTRUCT -L_RT- BEHIND BARRIER
THEN REMOVE PCB AND PLACE DRUMS
USE TEMP LANE CLOSURES TO WEDGE
TEMPORARY PAVEMENT TIE

END WEDGING -L_RT-
STA 13+00 +/-

	WORK AREA
	WEDGING & WIDENING
	TEMPORARY PAVEMENT
	PAVEMENT / BRIDGE REMOVAL

9/6/2023
B3186-B5898-TC-TMP-19-Phase IV.dgn
Jeffrey.Thurston

APPROVED: *Jeffrey A. Kooft*

DATE: 10/17/2023

PROFESSIONAL SEAL
018122
JEFFREY A. KOOFT
ENGINEER

**DOCUMENT NOT CONSIDERED FINAL
UNLESS ALL SIGNATURES COMPLETED**

DIVISION OF HIGHWAYS
STATE OF NORTH CAROLINA
DEPARTMENT OF TRANSPORTATION
WORK ZONE TRAFFIC CONTROL

AECOM
NC FIRM LICENSE No: F-0342
5438 Wade Park Blvd., Ste 200
Raleigh, NC 27607
(919) 854-6200

PHASE IV DETAILS
US 74/US 23

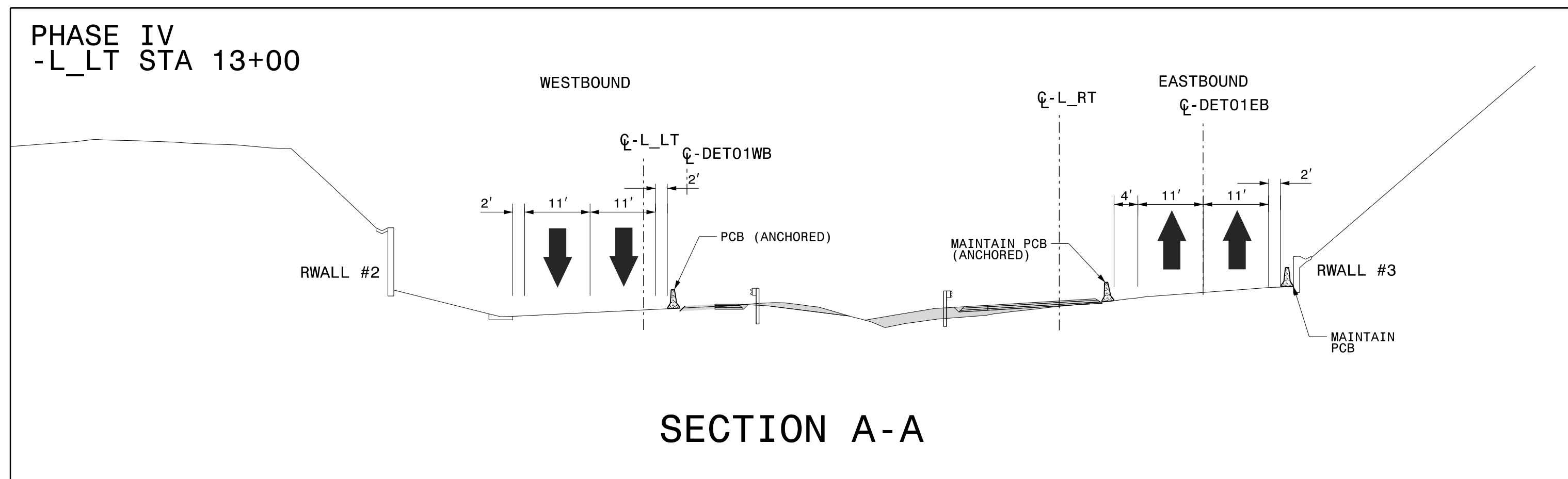
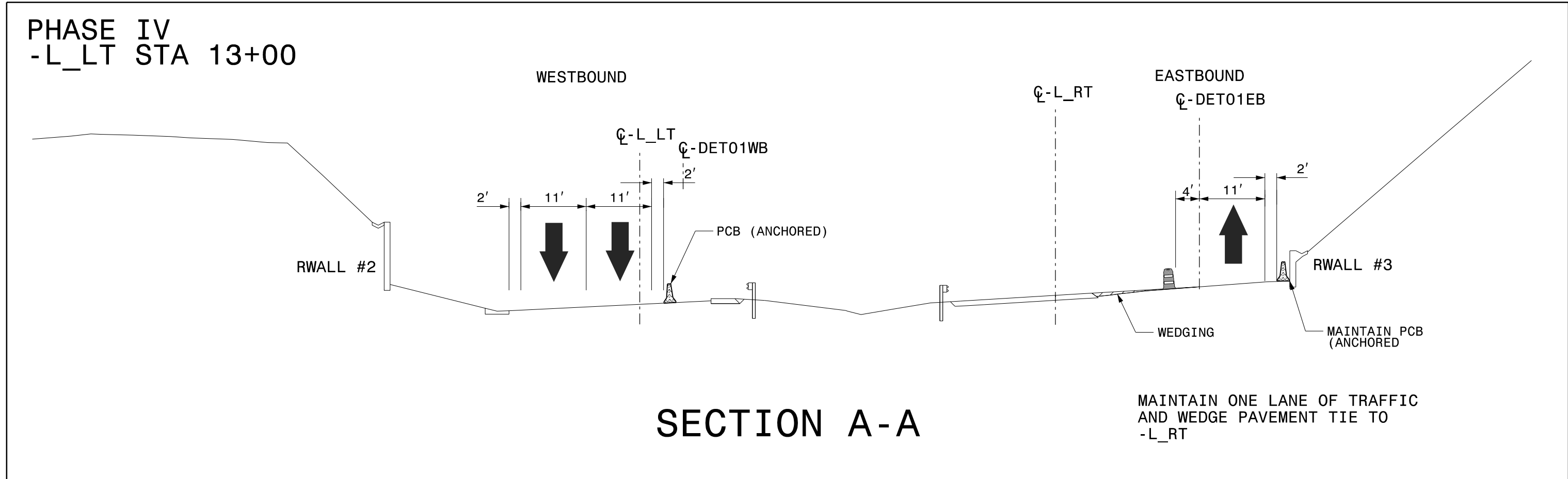

	WORK AREA
	WEDGING & WIDENING
	TEMPORARY PAVEMENT
	PAVEMENT / BRIDGE REMOVAL

9/6/2023
 B3186-B5898-TC-TMP-19A-Phase IV Section.dgn
 jeffrey.thurston

APPROVED: *Jeffrey A. Kooft*

DATE: 10/17/2023

**DOCUMENT NOT CONSIDERED FINAL
UNLESS ALL SIGNATURES COMPLETED**

AECOM
 NC FIRM LICENSE No: F-0342
 5438 Wade Park Blvd., Ste 200
 Raleigh, NC 27607
 (919) 854-6200

PHASE IV DETAILS
US 74/US 23

SEE TMP-20A FOR SECTION DETAILS

PHASE IV
-L_LT STA 22+50

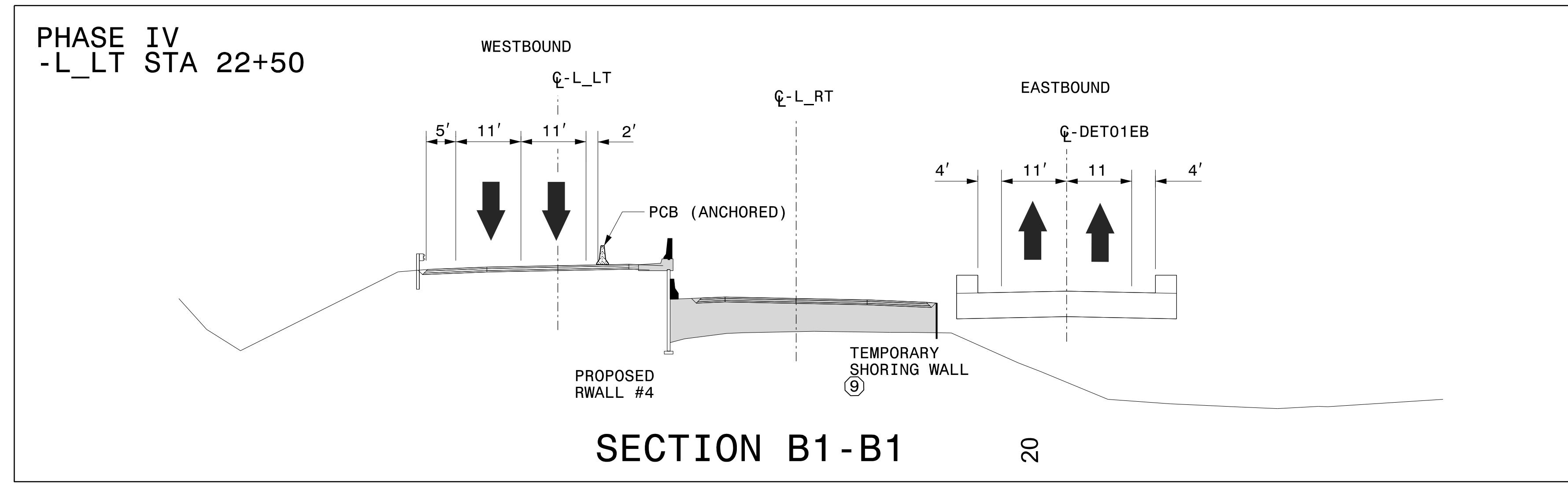

SECTION B1-B1

MATCHLINE -L_RT STA 15+00
SEE SHEET TMP-19

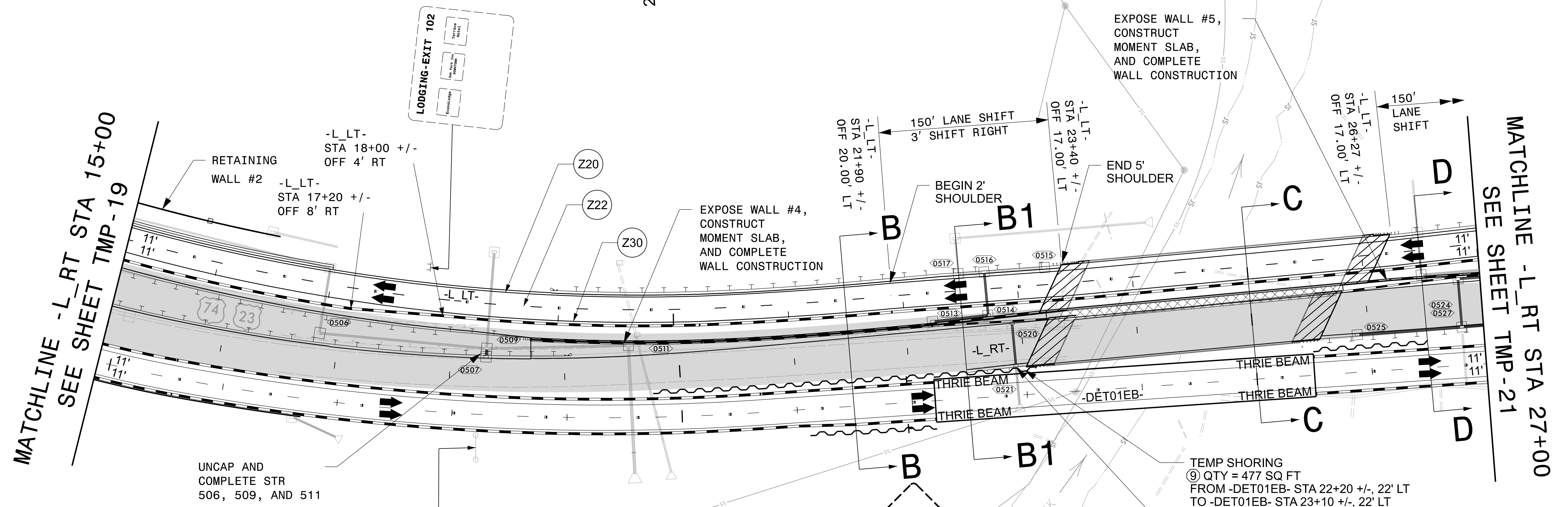

MATCHLINE -L_RT STA 27+00
SEE SHEET TMP-21

	WORK AREA
	WEDGING & WIDENING
	TEMPORARY PAVEMENT
	PAVEMENT / BRIDGE REMOVAL

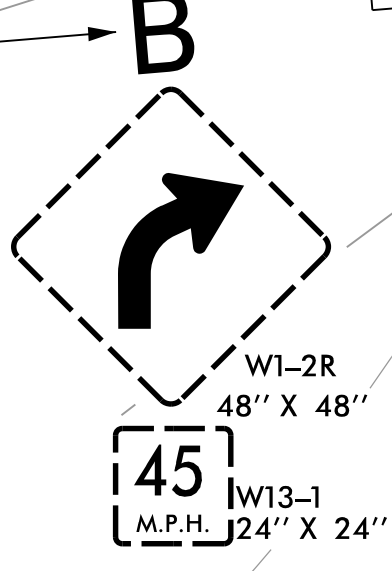
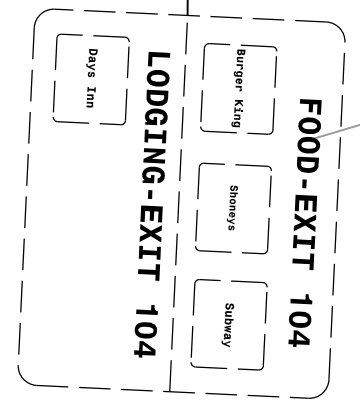

APPROVED: *Jeffrey A. Koontz*

DATE: 10/17/2023

**DOCUMENT NOT CONSIDERED FINAL
UNLESS ALL SIGNATURES COMPLETED**

AECOM
NC FIRM LICENSE No: F-0342
5438 Wade Park Blvd., Ste 200
Raleigh, NC 27607
(919) 854-6200

PHASE IV DETAILS
US 74/US 23

10/12/2023
B3186-B5898_TC_TMP-20_Phase IV.dgn
Jeff.Koontz

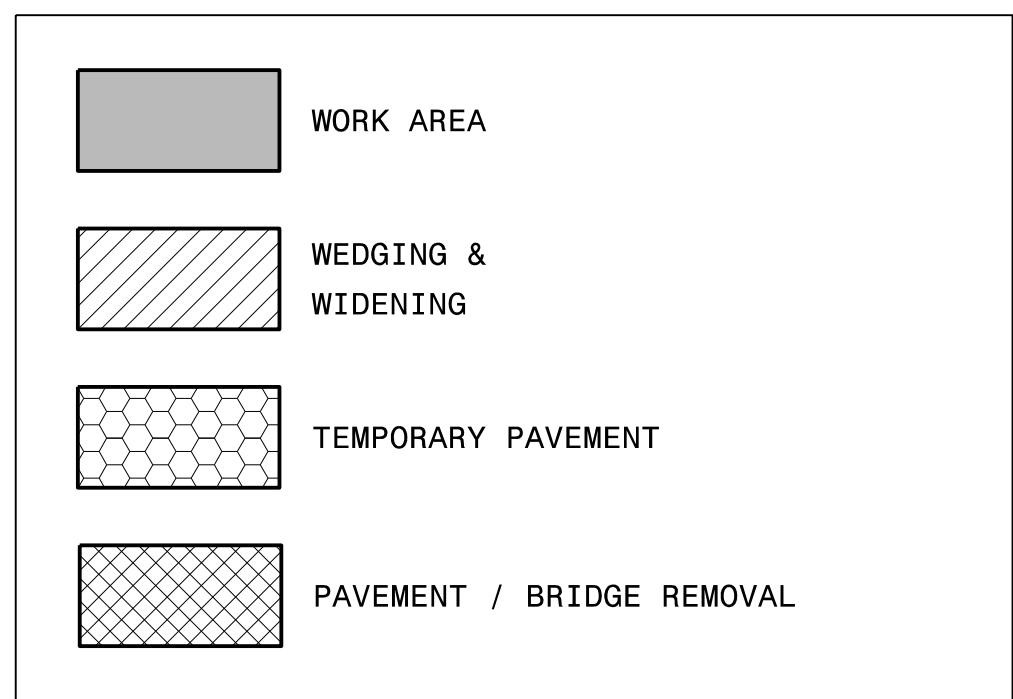
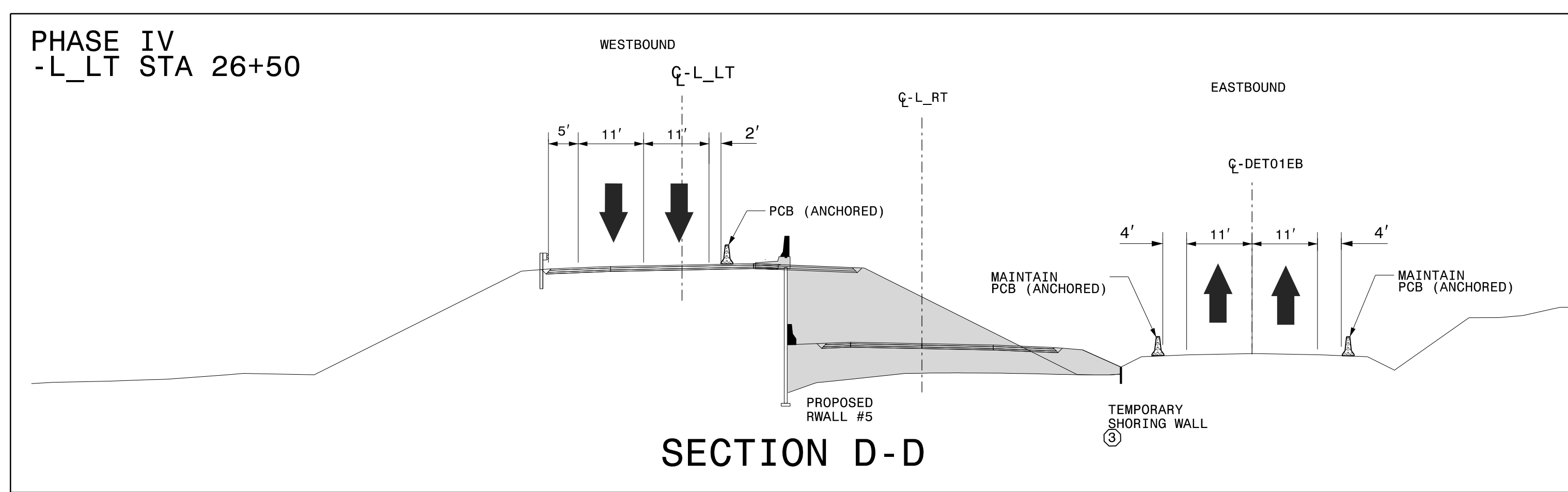
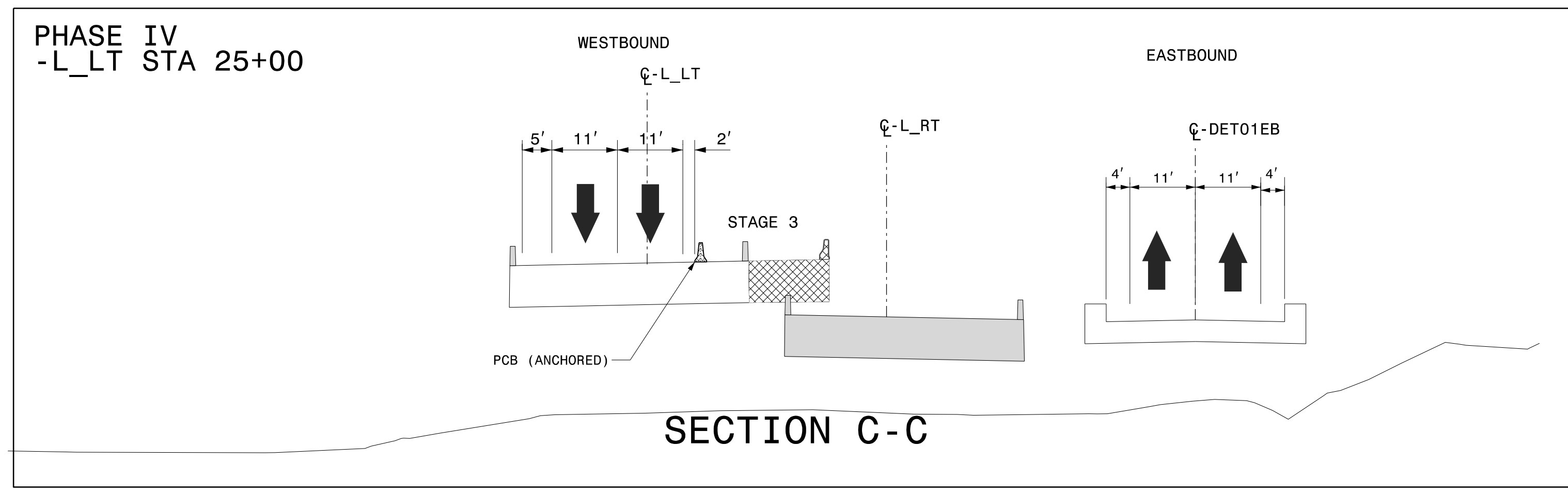
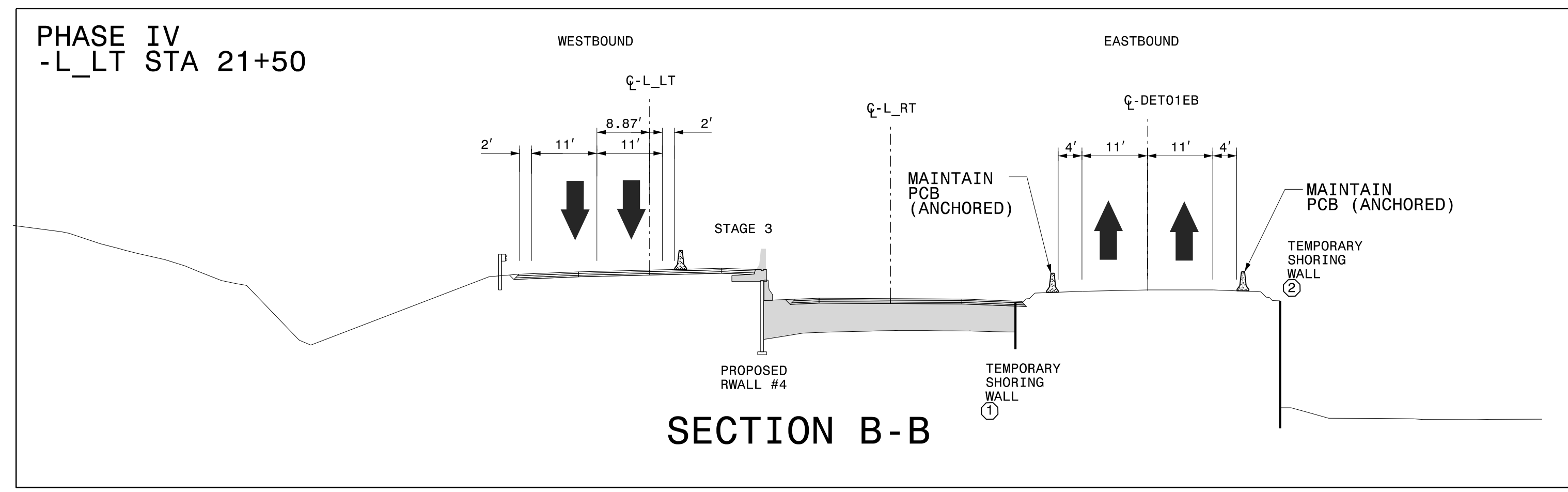

9/14/2023
 B3186-B5898-TC_TMP-20A_Phase IV Sections.dgn
 jeffrey.thurston

APPROVED: *Jeffrey A. Kooft*

DATE: 10/17/2023

**DOCUMENT NOT CONSIDERED FINAL
UNLESS ALL SIGNATURES COMPLETED**

AECOM
 NC FIRM LICENSE No: F-0342
 5438 Wade Park Blvd., Ste 200
 Raleigh, NC 27607
 (919) 854-6200

PHASE IV DETAILS
US 74/US 23

SEE TMP-21A FOR SECTION DETAILS

PROJ. REFERENCE NO.	SHEET NO.
B-3186 / B-5898	TMP-21

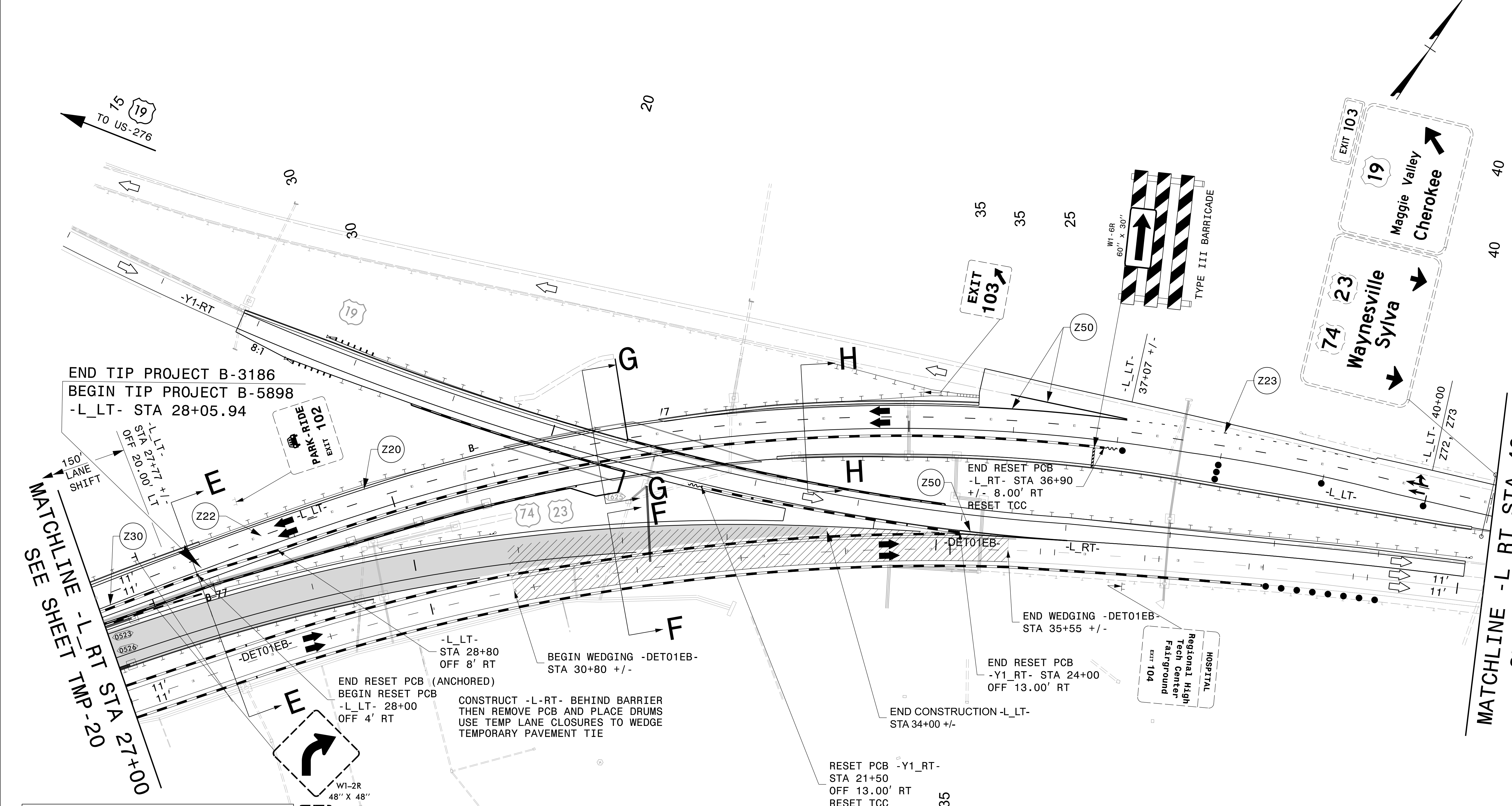

END TIP PROJECT B-3186
 BEGIN TIP PROJECT B-5898
 -L_LT- STA 28+05.94

MATCHLINE - L_RT STA 27+00
 SEE SHEET TMP-20

MATCHLINE - L_RT STA 40+25
 SEE SHEET TMP-22

	WORK AREA
	WEDGING & WIDENING
	TEMPORARY PAVEMENT
	PAVEMENT / BRIDGE REMOVAL

END RESET PCB (ANCHORED)
 BEGIN RESET PCB
 -L_LT- 28+00
 OFF 4' RT

CONSTRUCT -L_RT- BEHIND BARRIER
 THEN REMOVE PCB AND PLACE DRUMS
 USE TEMP LANE CLOSURES TO WEDGE
 TEMPORARY PAVEMENT TIE

-L_LT- STA 28+80
 OFF 8' RT

BEGIN WEDGING -DET01EB-
 STA 30+80 +/-

END RESET PCB
 -L_RT- STA 36+90
 +/- 8.00' RT
 RESET TCC

END WEDGING -DET01EB-
 STA 35+55 +/-

END RESET PCB
 -Y1_RT- STA 24+00
 OFF 13.00' RT

RESET PCB -Y1_RT-
 STA 21+50
 OFF 13.00' RT
 RESET TCC

APPROVED: *Jeffrey A. Koontz*

DATE: 10/17/2023

SEAL 018122
 ENGINEER
 JEFFREY A. KOONTZ

DOCUMENT NOT CONSIDERED FINAL
 UNLESS ALL SIGNATURES COMPLETED

DIVISION OF HIGHWAYS
 STATE OF NORTH CAROLINA
 DEPARTMENT OF TRANSPORTATION
 WORK ZONE TRAFFIC CONTROL

AECOM
 NC FIRM LICENSE No: F-0342
 5438 Wade Park Blvd., Ste 200
 Raleigh, NC 27607
 (919) 854-6200

PHASE IV DETAILS
 US 74/US 23

10/14/2023
 B3186-B5898_TC_TMP_21_Phase IV.dgn
 jeff.koontz

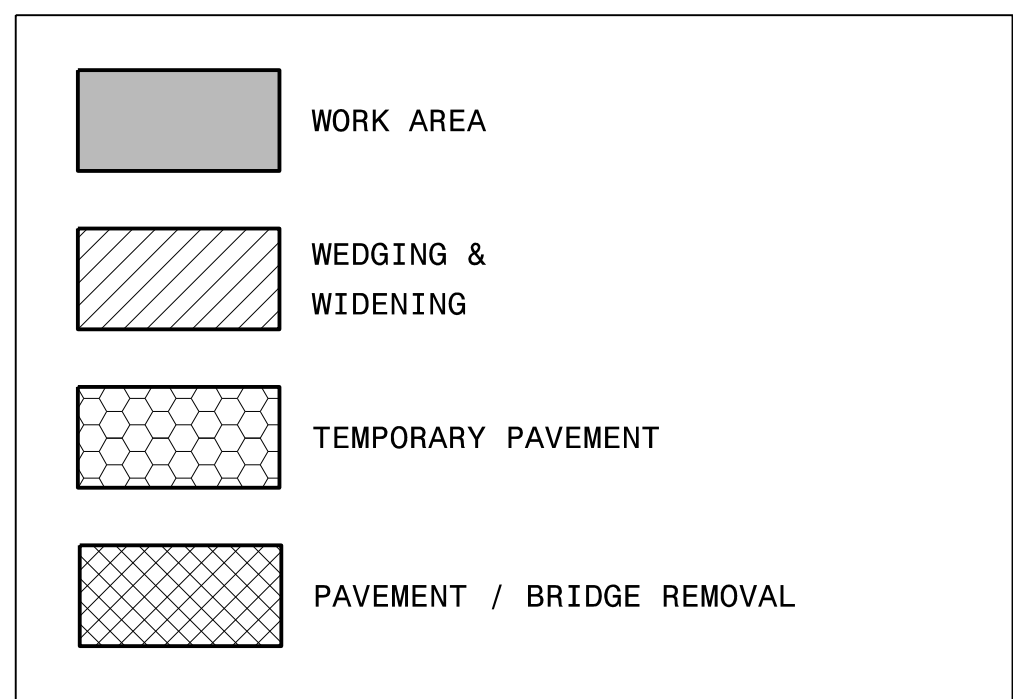
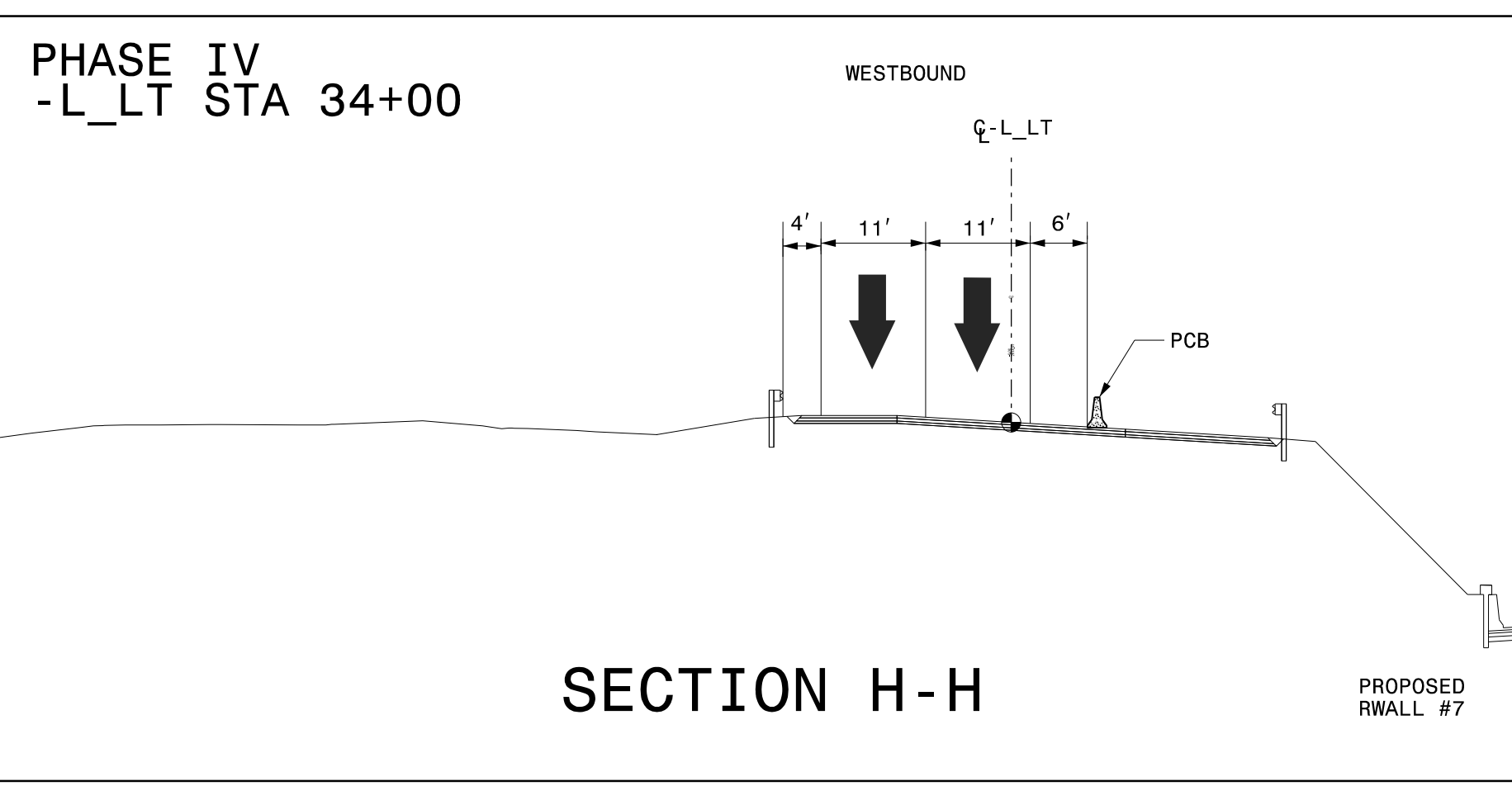
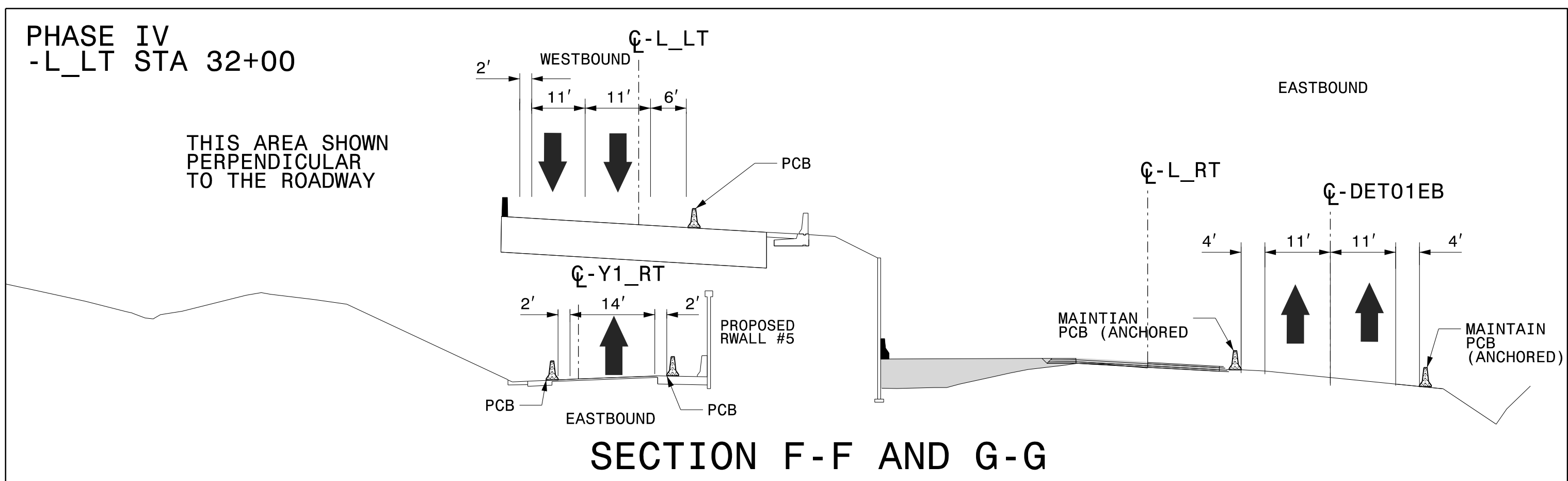
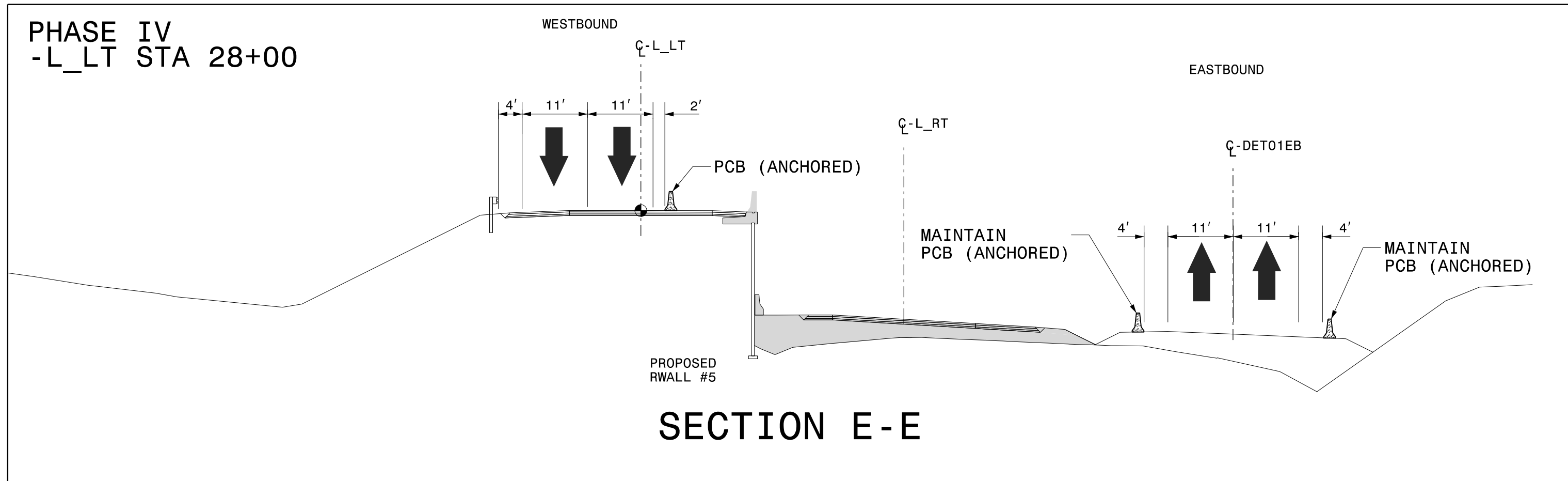
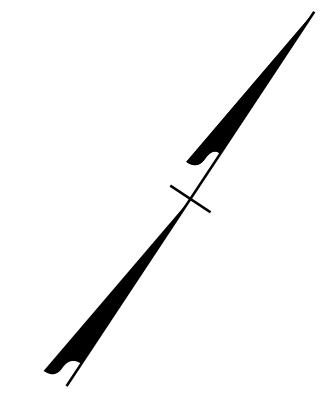

9/6/2023
 B3186-B5898-TC-TMP-21A-Phase IV Sections.dgn
 jeffrey.thurston

APPROVED: *Jeffrey A. Koontz*

DATE: 10/17/2023

**DOCUMENT NOT CONSIDERED FINAL
UNLESS ALL SIGNATURES COMPLETED**

AECOM
 NC FIRM LICENSE No: F-0342
 5438 Wade Park Blvd., Ste 200
 Raleigh, NC 27607
 (919) 854-6200

PHASE IV DETAILS
US 74/US 23

MATCHLINE -L_RT STA 40+25
SEE SHEET TMP-21

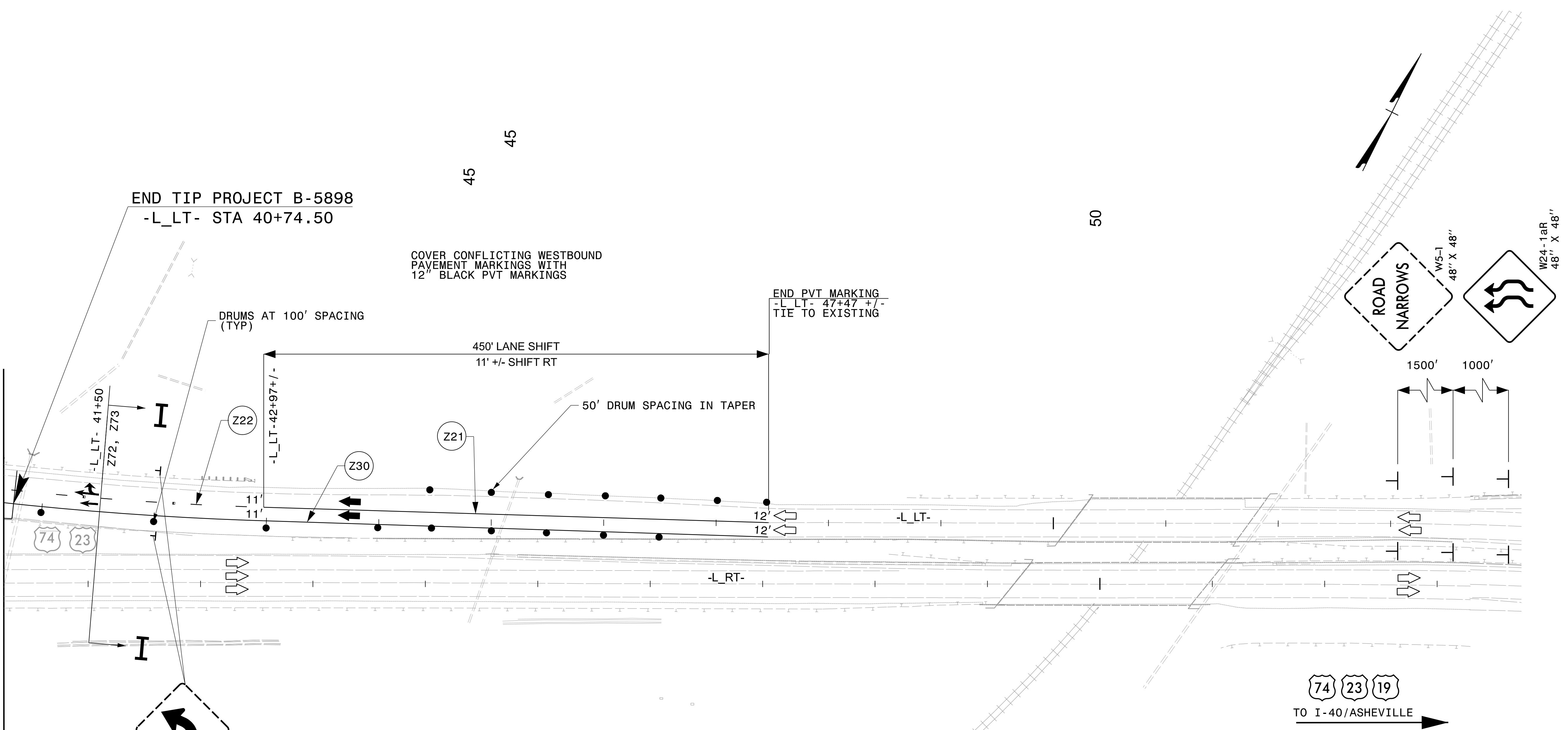

PHASE IV
-L_LT STA 41+50

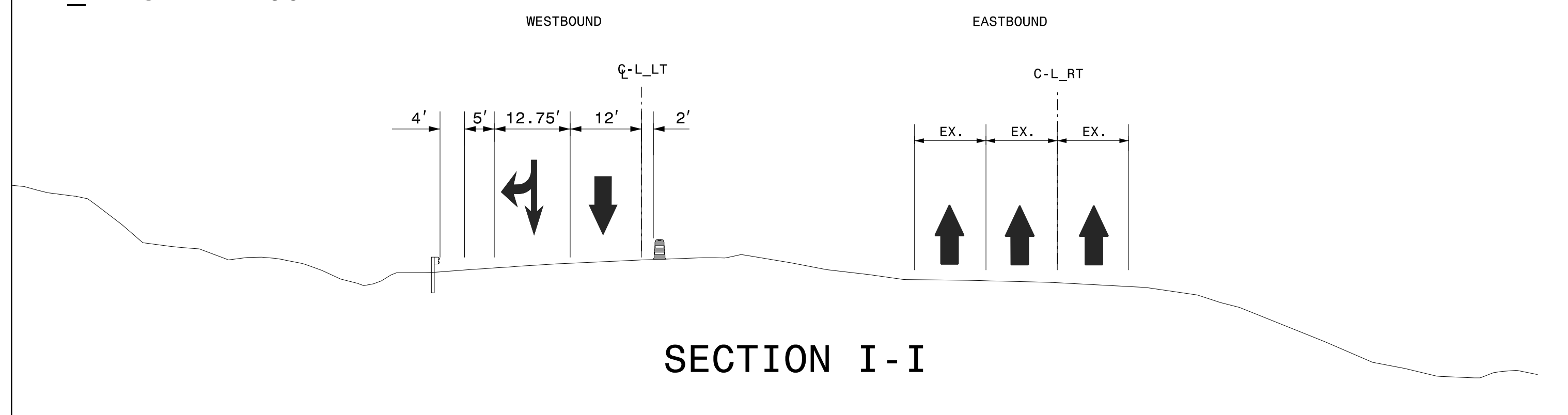

SECTION I-I

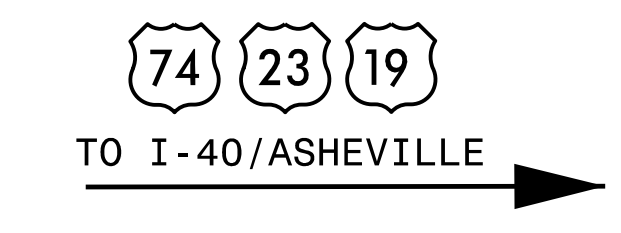

	WORK AREA
	WEDGING & WIDENING
	TEMPORARY PAVEMENT
	PAVEMENT / BRIDGE REMOVAL

APPROVED: *Jeffrey A. Kooft*
DATE: 10/17/2023

**DOCUMENT NOT CONSIDERED FINAL
UNLESS ALL SIGNATURES COMPLETED**

AECOM
NC FIRM LICENSE No: F-0342
5438 Wade Park Blvd., Ste 200
Raleigh, NC 27607
(919) 854-6200

PHASE IV DETAILS
US 74/US 23

9/6/2023
B3186-B5898-TC_TMP-22_Phase IV.dgn
Jeffrey.thurston

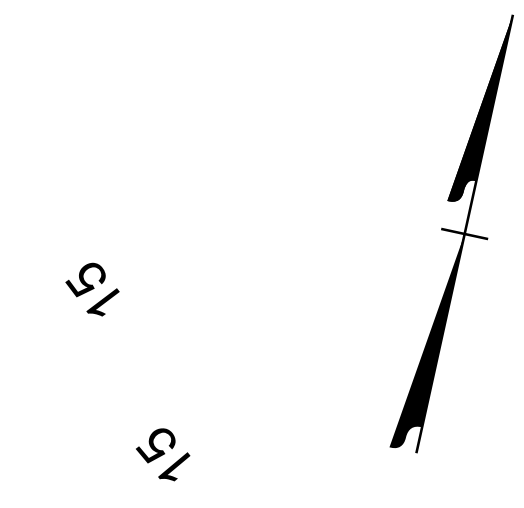
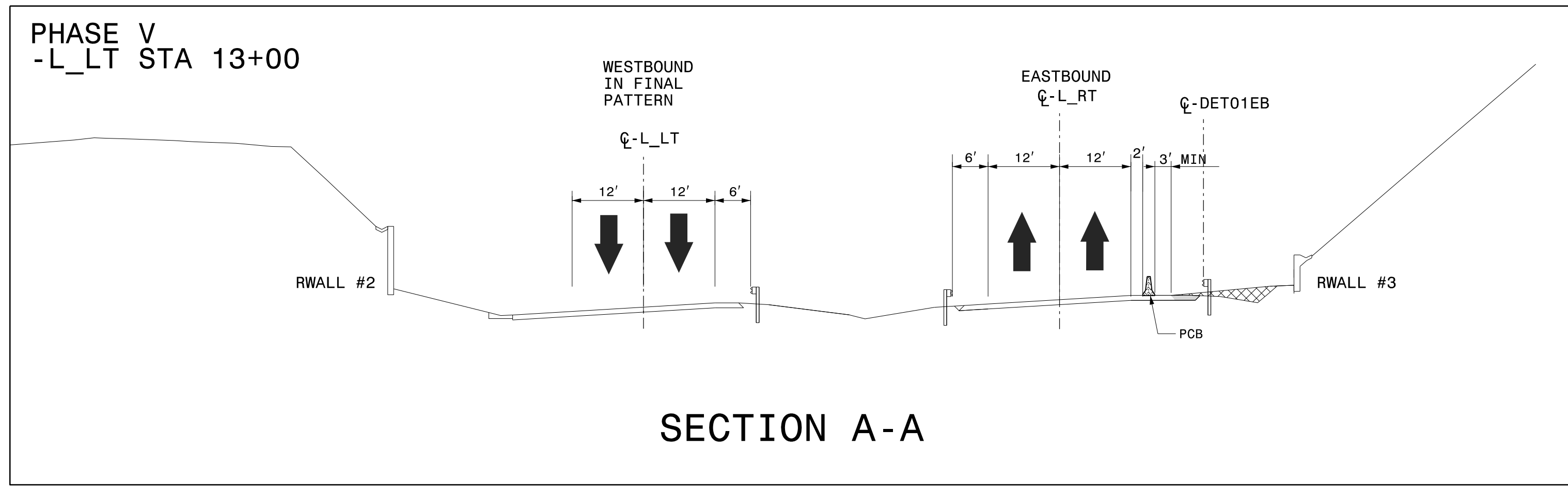

COVER CONFLICTING WESTBOUND PVT MARKINGS BEYOND FINAL PAVING LIMITS WITH 12" BLACK PVT MARKINGS AND PLACE PVT MARKINGS (THERMOPLASTIC) BACK IN ORIGINAL PATTERN FROM -L_RT- 3+00 +/- TO 6+89 +/- TIE TO EXISTING PVT MARKINGS

BEGIN TIP PROJECT B-3186 -L_LT- STA 6+89.01

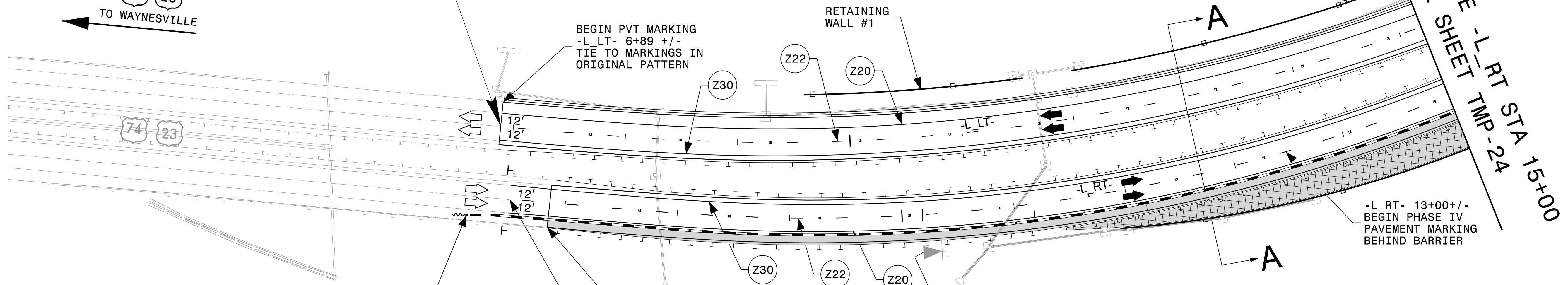
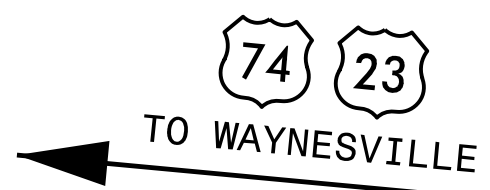

COVER CONFLICTING EASTBOUND PVT MARKINGS BEYOND FINAL PAVING LIMITS WITH 12" BLACK PVT MARKINGS AND PLACE PVT MARKINGS (THERMOPLASTIC) BACK IN ORIGINAL PATTERN FROM -L_RT- 6+50 +/- TO 6+86 +/- TIE TO EXISTING PVT MARKINGS

BEGIN RESET PCB -L_RT- STA 6+10 +/- OFF 14.00' RT RESET TCC

BEGIN CONSTRUCTION -L_RT- 6+86 +/-

BEGIN PVT MARKING -L_RT- 6+50 +/- TIE TO EXISTING IN ORIGINAL PATTERN

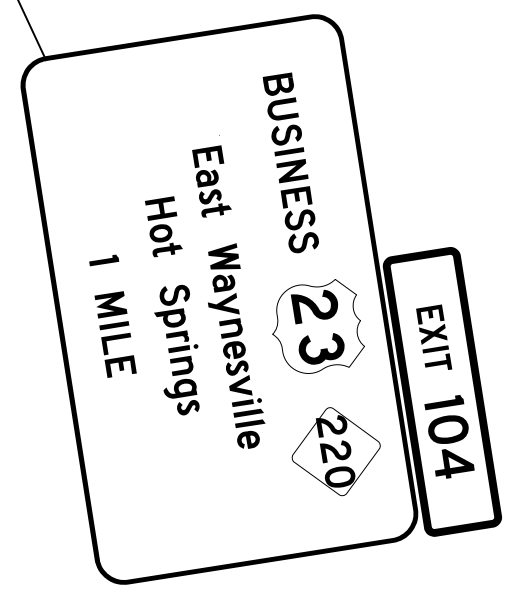

INSTALL NEW SIGN IN FINAL LOCATION (SEE SIGNING PLANS)

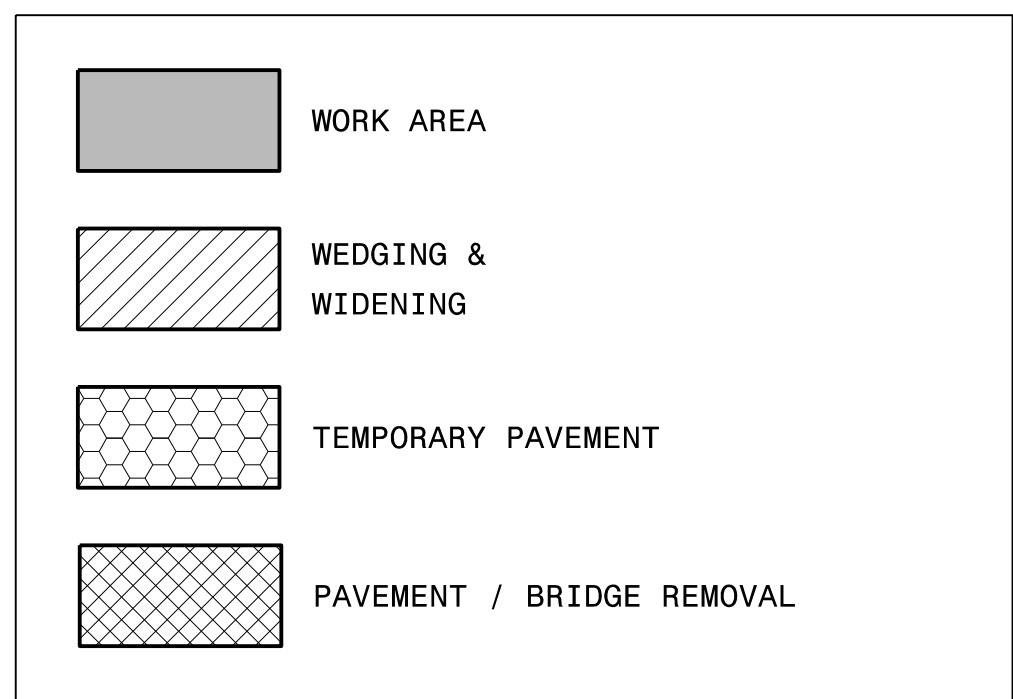

APPROVED: *Jeffrey A. Kooft*
 DATE: 10/17/2023

DOCUMENT NOT CONSIDERED FINAL UNLESS ALL SIGNATURES COMPLETED

AECOM
 NC FIRM LICENSE No: F-0342
 5438 Wade Park Blvd., Ste 200
 Raleigh, NC 27607
 (919) 854-6200

PHASE V DETAILS
 US 74/US 23

9/6/2023
 B3186-B5898-TC-TMP-23_Phase V.dgn
 Jeffrey Thurston

SEE TMP-24A FOR SECTION DETAILS

PROJ. REFERENCE NO.	SHEET NO.
B-3186 / B-5898	TMP-24

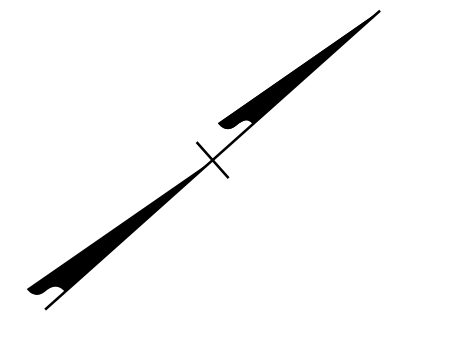

MATCHLINE -L_RT STA 15+00
SEE SHEET TMP-23

MATCHLINE -L_RT STA 27+00
SEE SHEET TMP-25

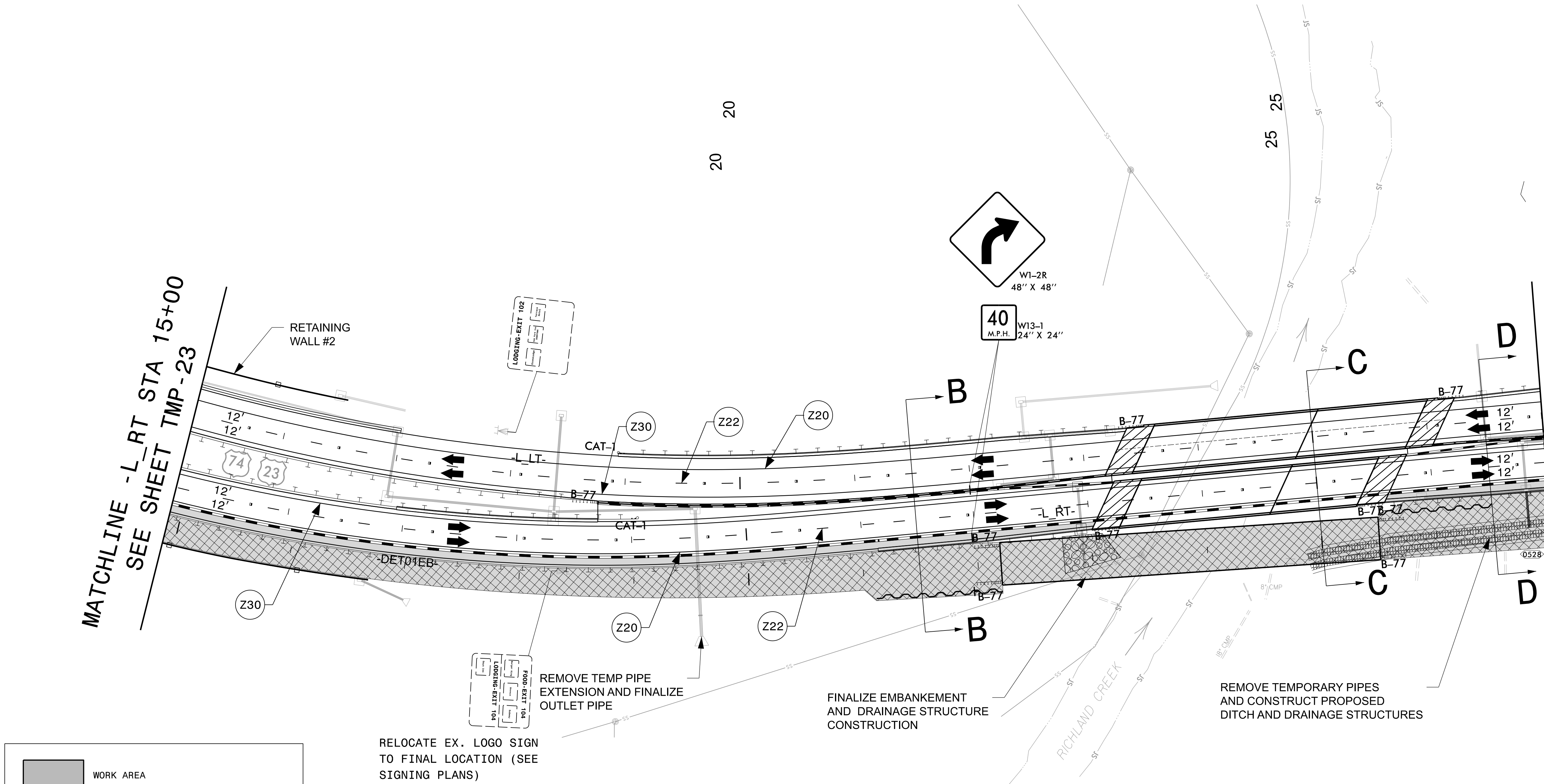

	WORK AREA
	WEDGING & WIDENING
	TEMPORARY PAVEMENT
	PAVEMENT / BRIDGE REMOVAL

RELOCATE EX. LOGO SIGN TO FINAL LOCATION (SEE SIGNING PLANS)

REMOVE TEMP PIPE EXTENSION AND FINALIZE OUTLET PIPE

FINALIZE EMBANKMENT AND DRAINAGE STRUCTURE CONSTRUCTION

REMOVE TEMPORARY PIPES AND CONSTRUCT PROPOSED DITCH AND DRAINAGE STRUCTURES

9/14/2023
 B3186-B5898.TC_TMP-24_Phase V.dgn
 jeffrey.thurston

APPROVED: *Jeffrey A. Kooft*

DATE: 10/17/2023

DOCUMENT NOT CONSIDERED FINAL UNLESS ALL SIGNATURES COMPLETED

AECOM
 NC FIRM LICENSE No: F-0342
 5438 Wade Park Blvd., Ste 200
 Raleigh, NC 27607
 (919) 854-6200

PHASE V DETAILS
US 74/US 23

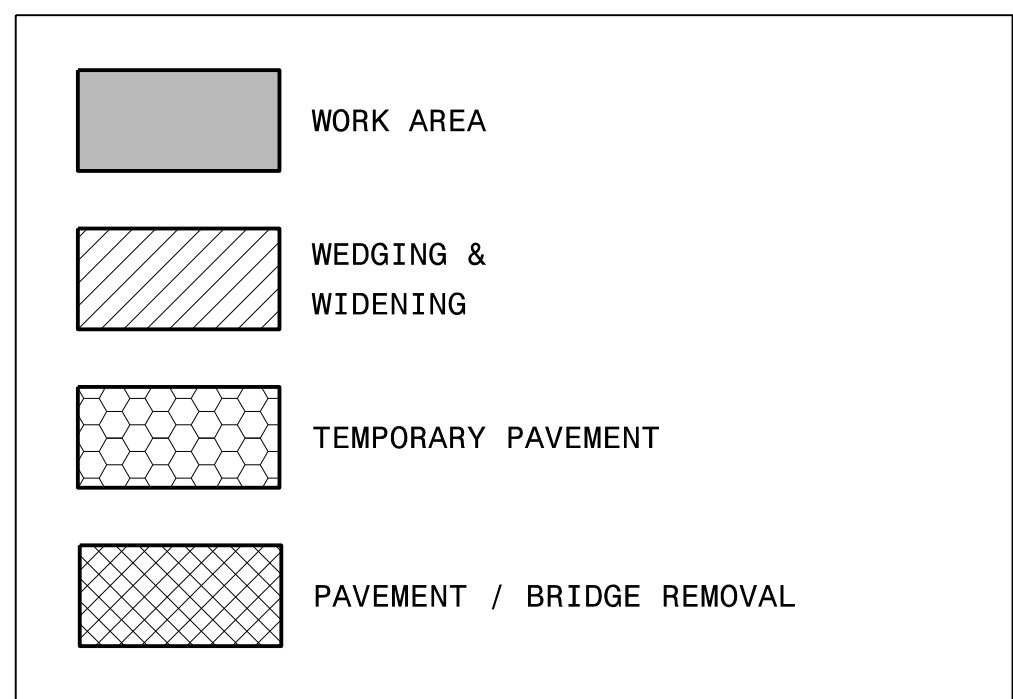
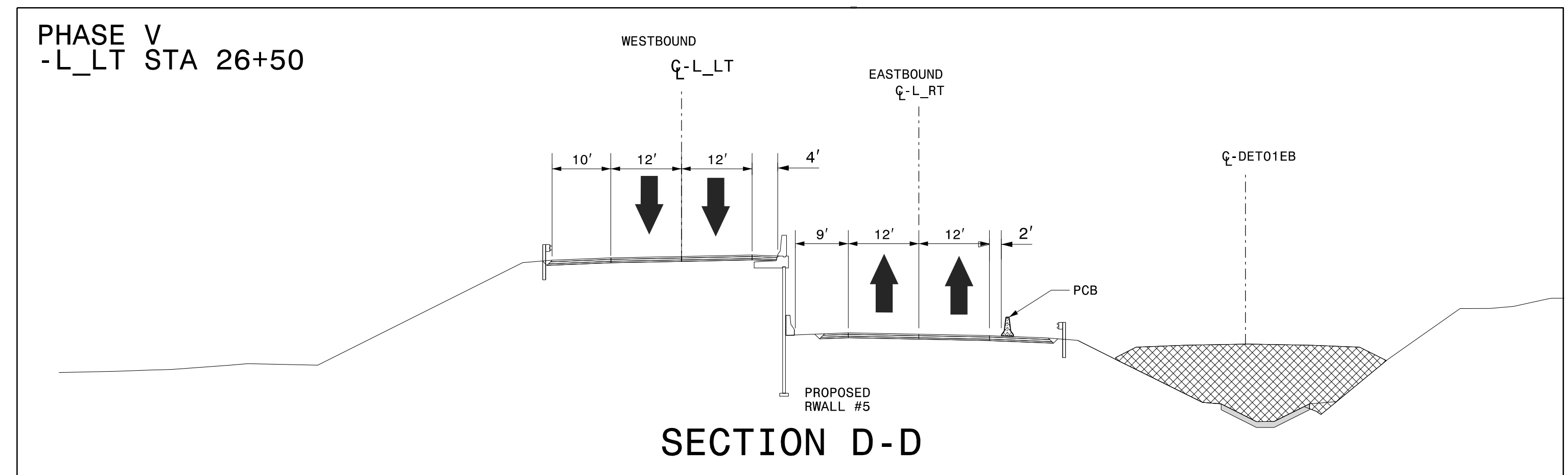
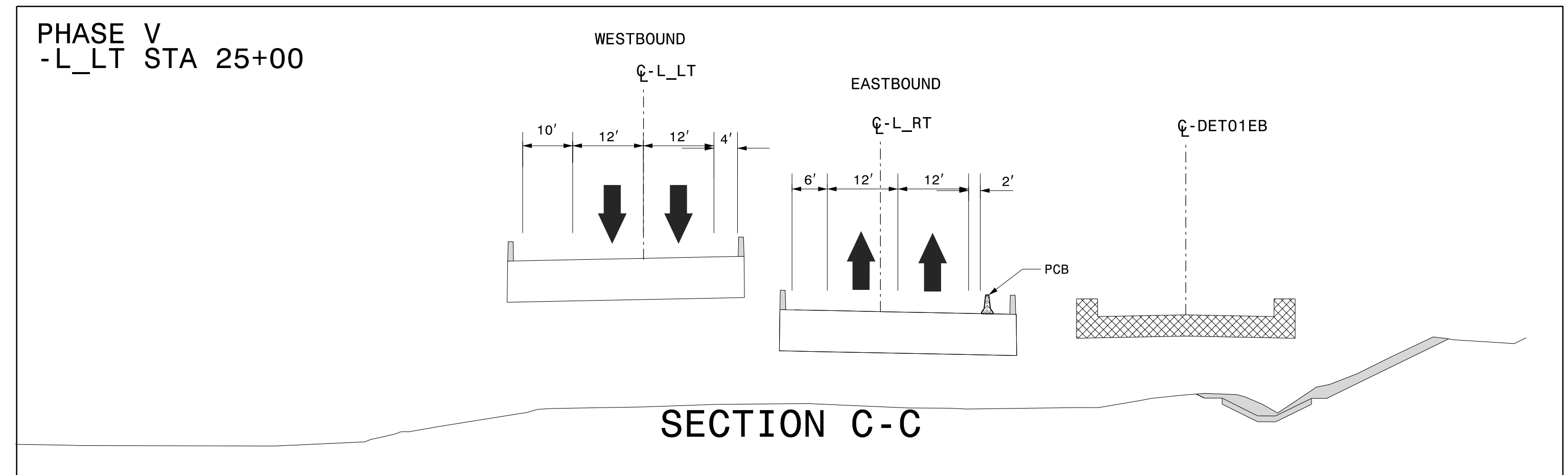
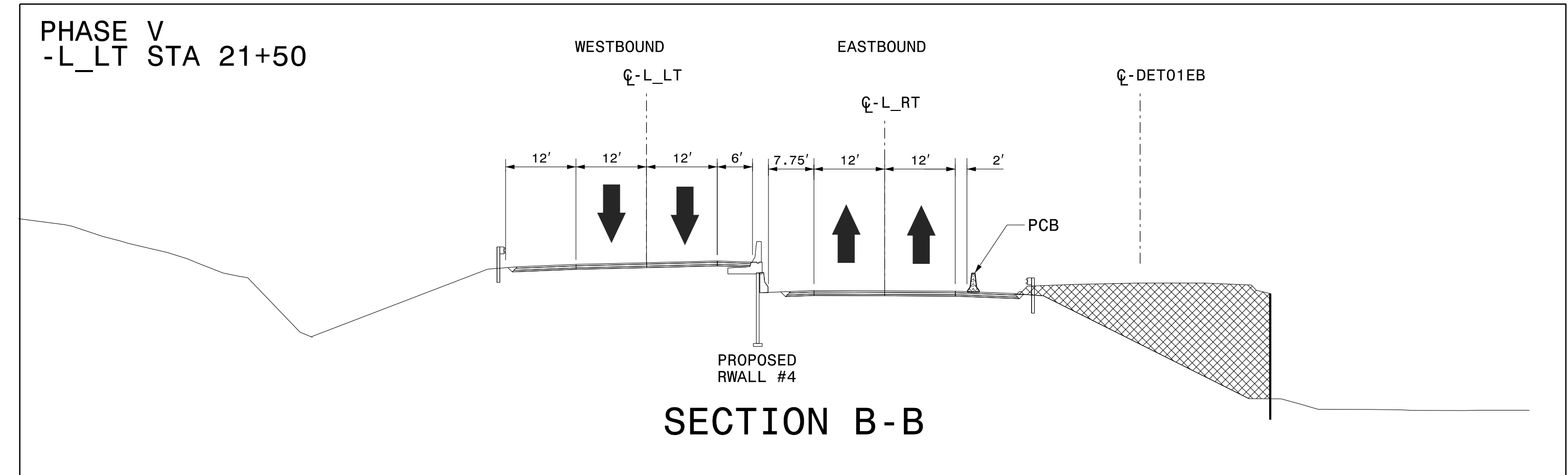

9/6/2023
 B3186-B5898-TC-TMP-24A_Phase V Sections.dgn
 jeffrey.thurston

APPROVED: *Jeffrey A. Koontz*

DATE: 10/17/2023

**DOCUMENT NOT CONSIDERED FINAL
UNLESS ALL SIGNATURES COMPLETED**

AECOM
 NC FIRM LICENSE No: F-0342
 5438 Wade Park Blvd., Ste 200
 Raleigh, NC 27607
 (919) 854-6200

PHASE V DETAILS
US 74/US 23

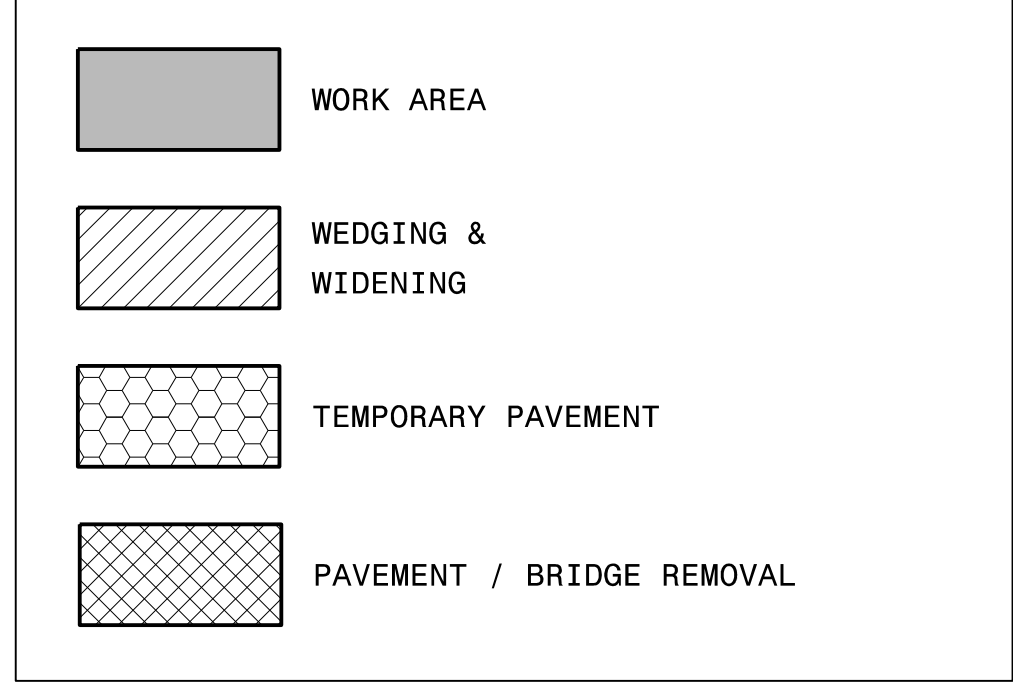
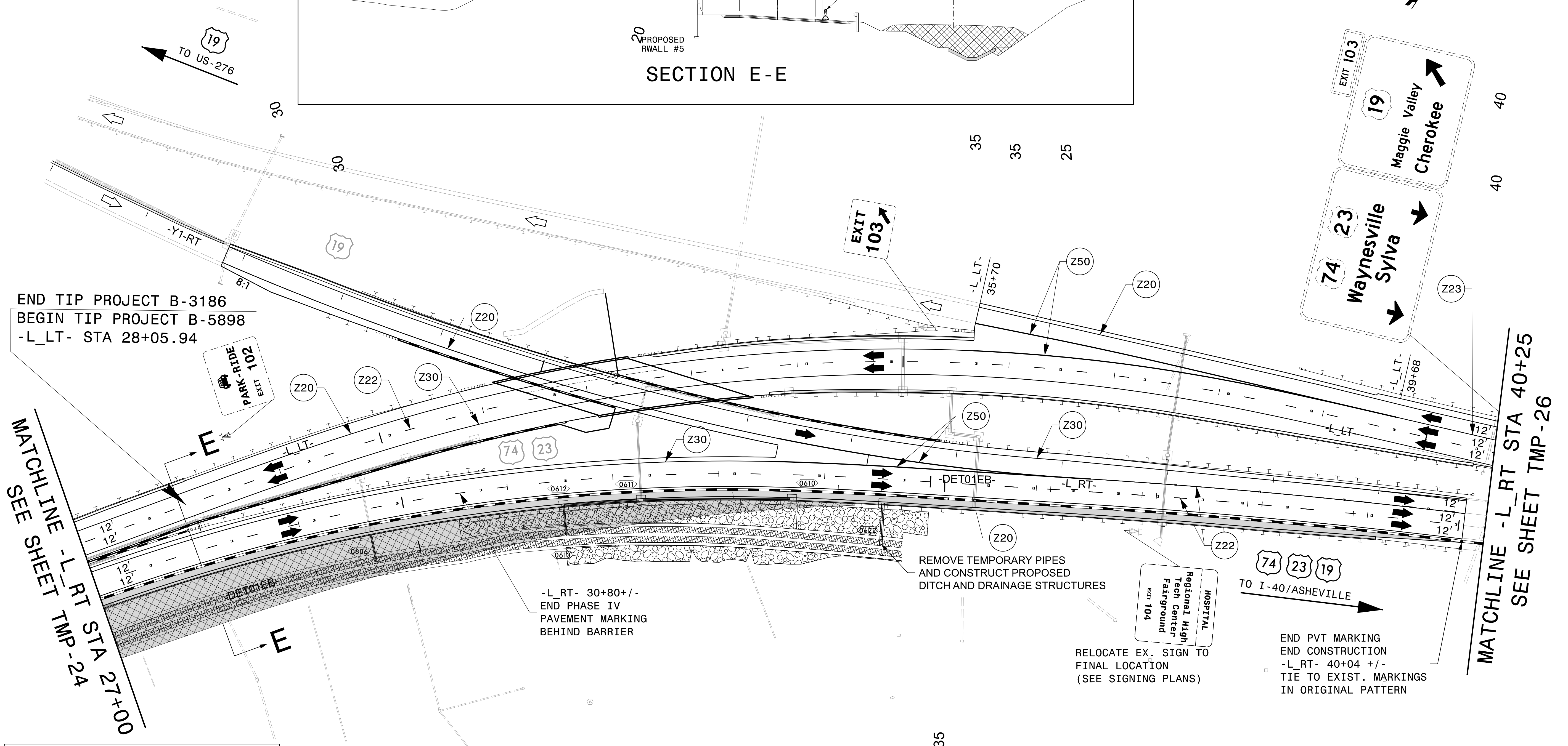
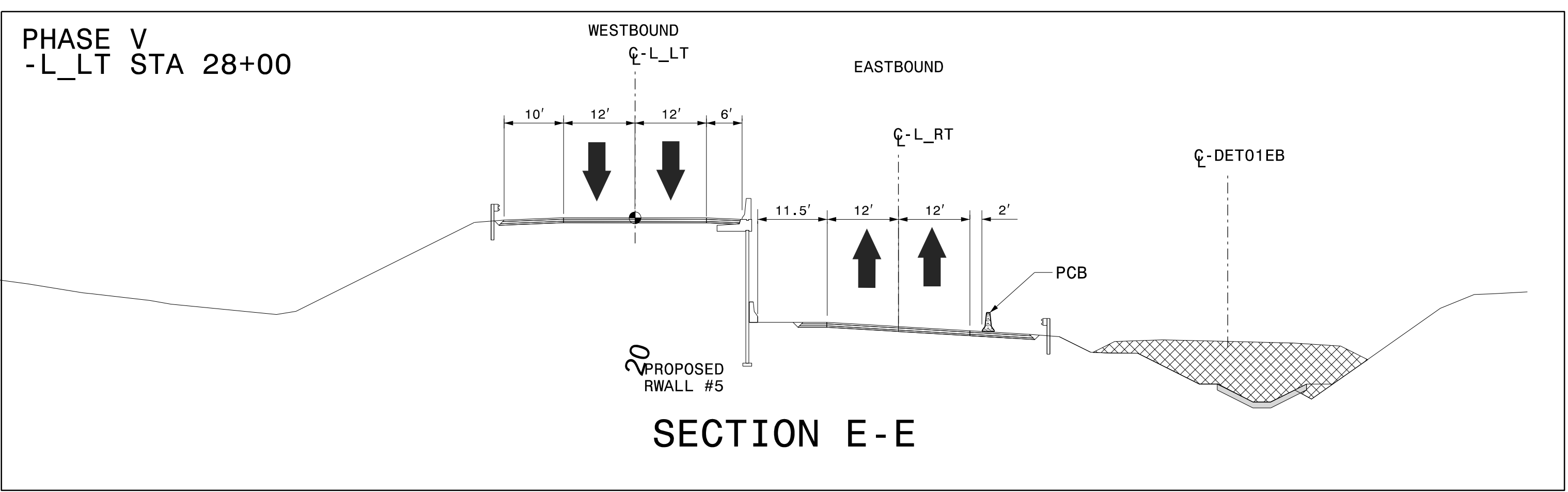

APPROVED: *Jeffrey A. Koontz*

DATE: 10/17/2023

Professional Engineer Seal: NORTH CAROLINA PROFESSIONAL SEAL 018122, ENGINEER, JEFFREY A. KOONTZ

DOCUMENT NOT CONSIDERED FINAL UNLESS ALL SIGNATURES COMPLETED

DIVISION OF HIGHWAYS
STATE OF NORTH CAROLINA
DEPARTMENT OF TRANSPORTATION & TRAFFIC CONTROL

AECOM
NC FIRM LICENSE No: F-0342
5438 Wade Park Blvd., Ste 200
Raleigh, NC 27607
(919) 854-6200

PHASE V DETAILS
US 74/US 23

10/14/2023
B3186-B5898_TC_TMP-25_Phase V.dgn
Jeff.Koontz

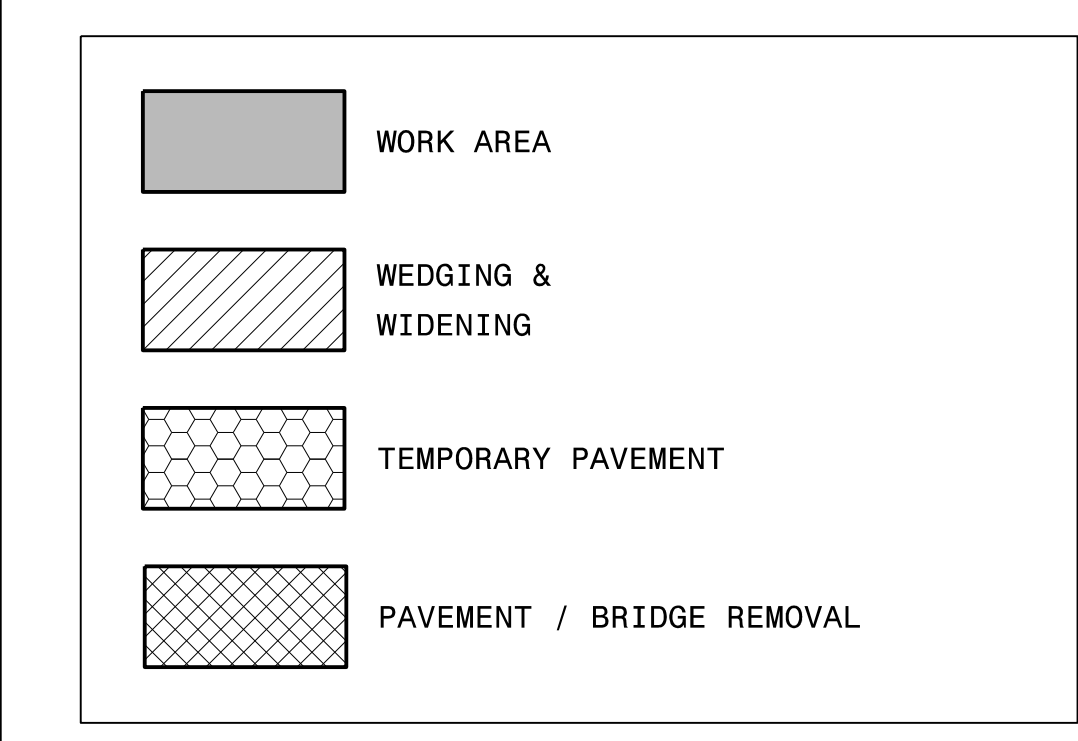
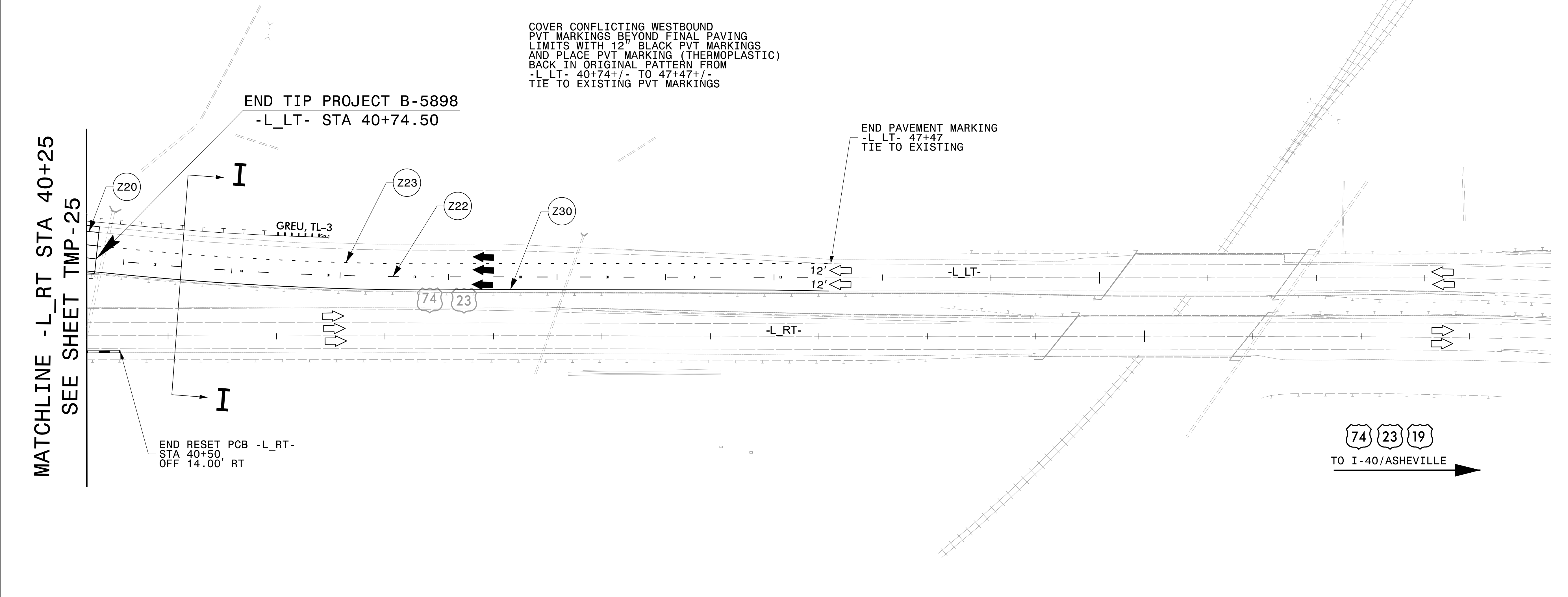
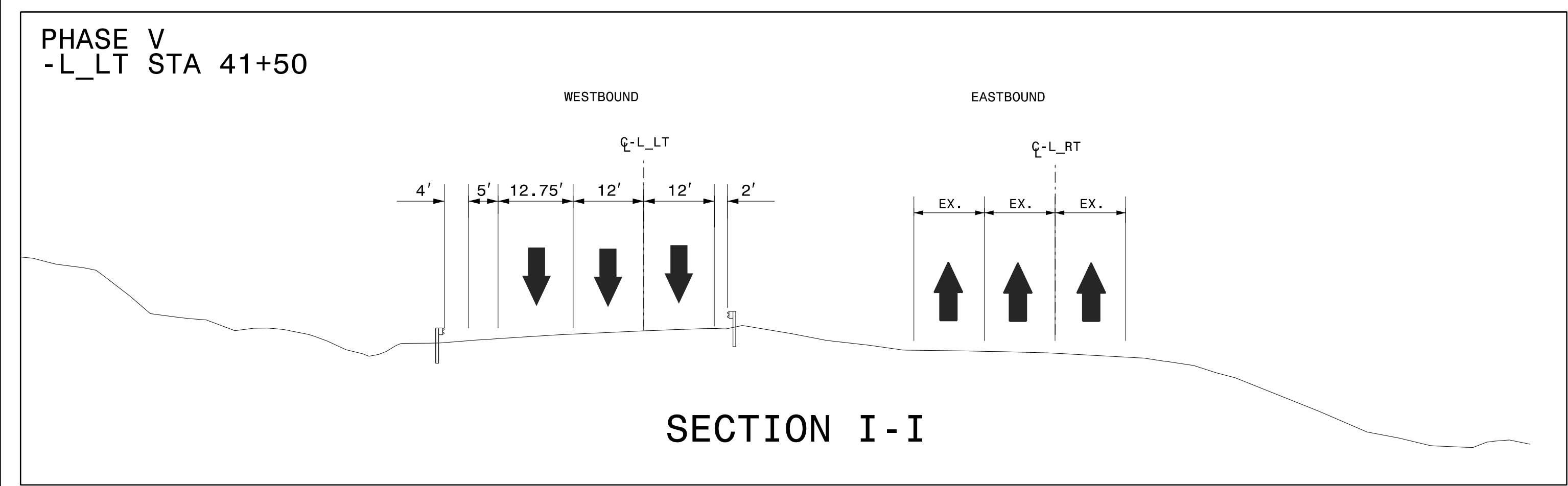

9/6/2023
 B3186-B5898_TC_TMP-26_Phase V.dgn
 jeffrey.thurston

APPROVED: *Jeffrey A. Kooft*

DATE: 10/17/2023

**DOCUMENT NOT CONSIDERED FINAL
UNLESS ALL SIGNATURES COMPLETED**

AECOM
 NC FIRM LICENSE No: F-0342
 5438 Wade Park Blvd., Ste 200
 Raleigh, NC 27607
 (919) 854-6200

PHASE V DETAILS
US 74/US 23