

Existing 12 CT Fiber Optic Cable Terminates in Server Room of the NCDOT TMC Building At 619 Paragon Pkwy.

CCTV-2 GPS COORDINATES
35.527805° N
82.947775° W

DMS-1 / CCTV-2
DMS = TYPE 2C

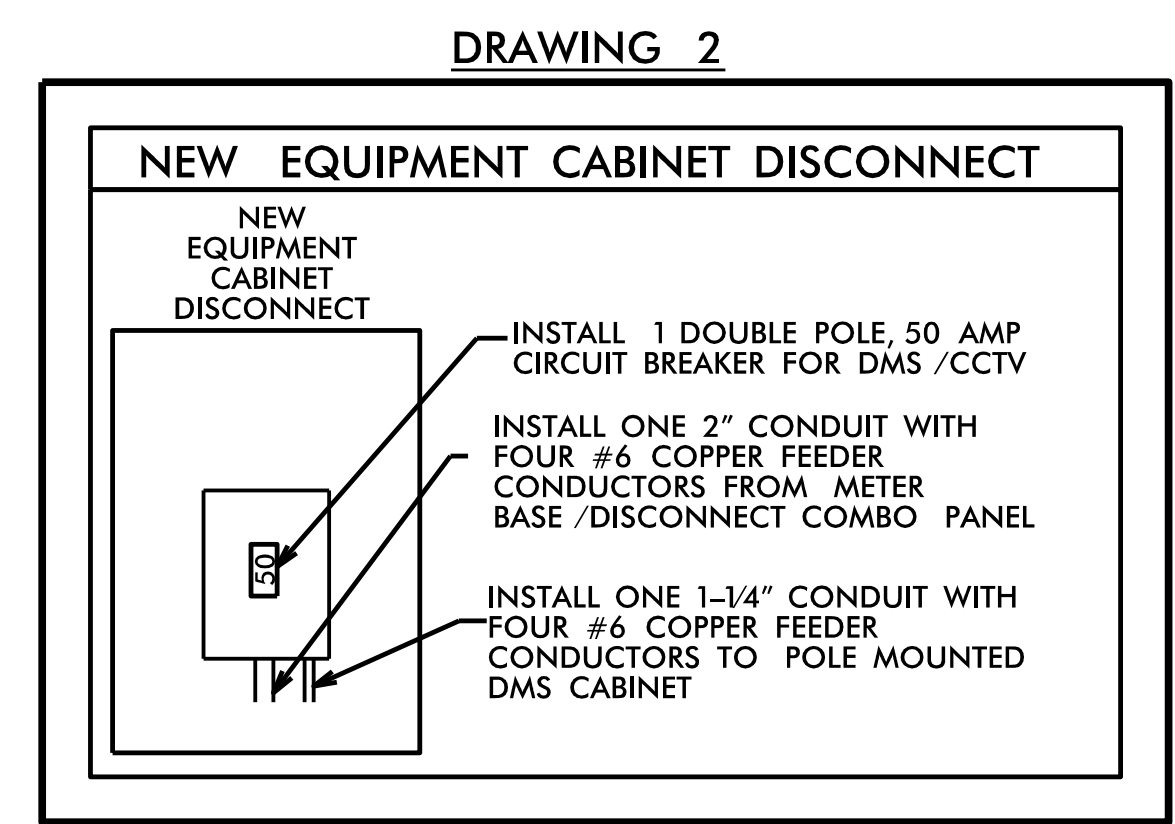
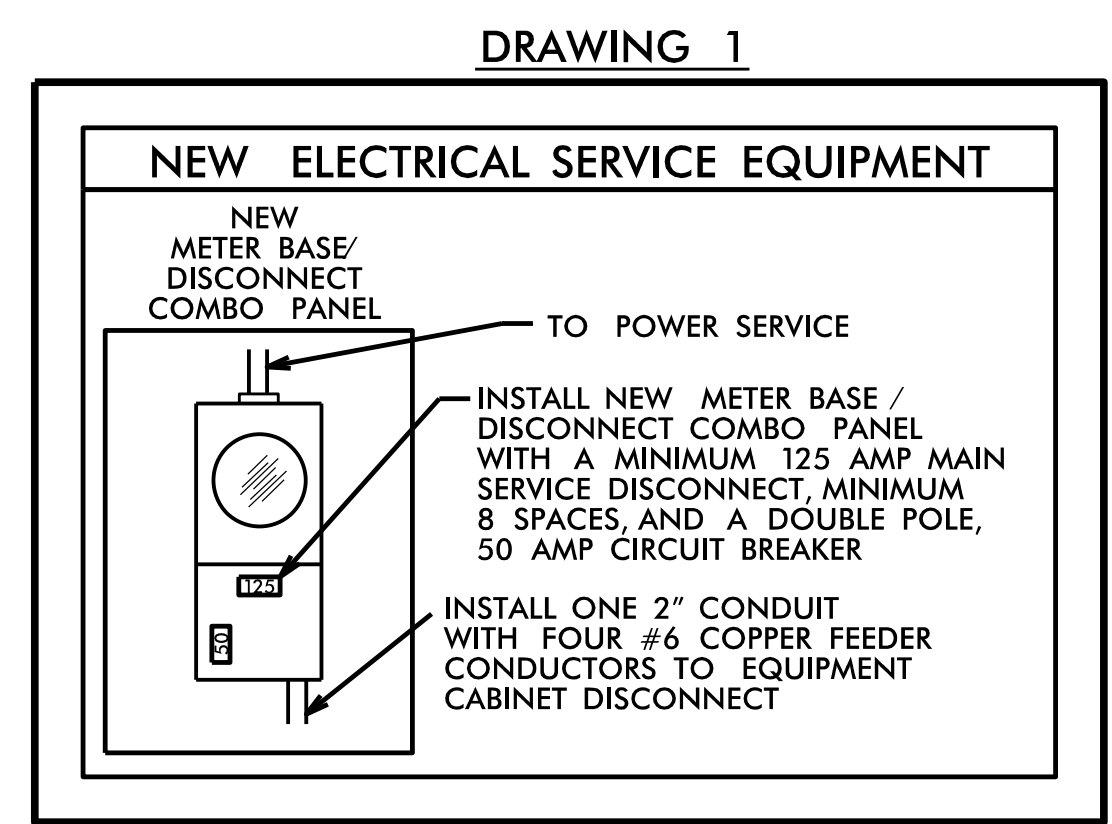

40B REPLACE EXISTING JUNCTION BOX

NOTES:

1. PROPOSED 294 FEET OF GUARDRAIL.

DOCUMENT NOT CONSIDERED FINAL UNLESS ALL SIGNATURES COMPLETED

8/4/2023 8:41:11 AM p:\aecom\nc\p\w\ben\1\ey.com\AECOM_USA_North\Carolina\Documents\60670367-1\NCDOT_B5898_B3186\900-CAD_GIS\910-CAD\70\NCDOT_TIP\inter\igent Transportation Systems\B-5898-ITS_PSH13.dgn T:\ndm

AECOM
NC Firm License No.: F-0342
5438 Wade Park Boulevard
Suite 200 Raleigh, NC 27607
Phone: 919-461-1100

Prepared for the Offices of:

750 N. Greenfield Pkwy., Garner, NC 27529

SCALE
0 50
1"=50'

ITS Communication Cable and Conduit Routing Plans

Division 14 Haywood County Waynesville

PLAN DATE: August 2023 REVIEWED BY: R. Garrett

PREPARED BY: M. Tindal REVIEWED BY:

REVISIONS	INIT.	DATE

SEAL

DocuSigned by:
Rochelle Garrett
8/4/2023

CADD Filename: