

STATE OF NORTH CAROLINA
DEPARTMENT OF TRANSPORTATION
RALEIGH, N.C.

PROPOSAL

INCLUDES ADDENDUM No.1 DATED 12-07-2023

DATE AND TIME OF BID OPENING: **Dec 19, 2023 AT 02:00 PM**

CONTRACT ID C204845
WBS 49987.3.1, 49988.3.1

FEDERAL-AID NO. 0074244, 4998831
COUNTY ROBESON, COLUMBUS
T.I.P NO. HI-0016, HI-0017
MILES 12.648
ROUTE NO. US-74
LOCATION FUTURE I-74: US-74 FROM E OF NC-41 TO LUMBER RIVER BRIDGES AND US-74 FROM SCOTLAND CO LINE TO I-74/US-74 BUS.

TYPE OF WORK DRAINAGE, PAVEMENT REHABILITATION, AND BRIDGE PRESERVATION.

NOTICE:

ALL BIDDERS SHALL COMPLY WITH ALL APPLICABLE LAWS REGULATING THE PRACTICE OF GENERAL CONTRACTING AS CONTAINED IN CHAPTER 87 OF THE GENERAL STATUTES OF NORTH CAROLINA WHICH REQUIRES THE BIDDER TO BE LICENSED BY THE N.C. LICENSING BOARD FOR CONTRACTORS WHEN BIDDING ON ANY NON-FEDERAL AID PROJECT WHERE THE BID IS \$30,000 OR MORE, EXCEPT FOR CERTAIN SPECIALTY WORK AS DETERMINED BY THE LICENSING BOARD. BIDDERS SHALL ALSO COMPLY WITH ALL OTHER APPLICABLE LAWS REGULATING THE PRACTICES OF ELECTRICAL, PLUMBING, HEATING AND AIR CONDITIONING AND REFRIGERATION CONTRACTING AS CONTAINED IN CHAPTER 87 OF THE GENERAL STATUTES OF NORTH CAROLINA. NOTWITHSTANDING THESE LIMITATIONS ON BIDDING, THE BIDDER WHO IS AWARDED ANY FEDERAL - AID FUNDED PROJECT SHALL COMPLY WITH CHAPTER 87 OF THE GENERAL STATUTES OF NORTH CAROLINA FOR LICENSING REQUIREMENTS WITHIN 60 CALENDAR DAYS OF BID OPENING.

BIDS WILL BE RECEIVED AS SHOWN BELOW:

THIS IS A ROADWAY & STRUCTURE PROPOSAL

5% BID BOND OR BID DEPOSIT REQUIRED

**PROPOSAL FOR THE CONSTRUCTION OF
CONTRACT No. C204845 IN COLUMBUS AND ROBESON COUNTIES, NORTH CAROLINA
DEPARTMENT OF TRANSPORTATION,
RALEIGH, NORTH CAROLINA**

The Bidder has carefully examined the location of the proposed work to be known as Contract No. **C204845** has carefully examined the plans and specifications, which are acknowledged to be part of the proposal, the special provisions, the proposal, the form of contract, and the forms of contract payment bond and contract performance bond; and thoroughly understands the stipulations, requirements and provisions. The undersigned bidder agrees to be bound upon his execution of the bid and subsequent award to him by the Board of Transportation in accordance with this proposal to provide the necessary contract payment bond and contract performance bond within fourteen days after the written notice of award is received by him. The undersigned Bidder further agrees to provide all necessary machinery, tools, labor, and other means of construction; and to do all the work and to furnish all materials, except as otherwise noted, necessary to perform and complete the said contract in accordance with *the 2018 Standard Specifications for Roads and Structures* by the dates(s) specified in the Project Special Provisions and in accordance with the requirements of the Engineer, and at the unit or lump sum prices, as the case may be, for the various items given on the sheets contained herein.

The Bidder shall provide and furnish all the materials, machinery, implements, appliances and tools, and perform the work and required labor to construct and complete State Highway Contract No. **C204845** in **Columbus and Robeson Counties**, for the unit or lump sum prices, as the case may be, bid by the Bidder in his bid and according to the proposal, plans, and specifications prepared by said Department, which proposal, plans, and specifications show the details covering this project, and hereby become a part of this contract.

The published volume entitled *North Carolina Department of Transportation, Raleigh, Standard Specifications for Roads and Structures, January 2018* with all amendments and supplements thereto, is by reference incorporated into and made a part of this contract; that, except as herein modified, all the construction and work included in this contract is to be done in accordance with the specifications contained in said volume, and amendments and supplements thereto, under the direction of the Engineer.

If the proposal is accepted and the award is made, the contract is valid only when signed either by the Contract Officer or such other person as may be designated by the Secretary to sign for the Department of Transportation. The conditions and provisions herein cannot be changed except over the signature of the said Contract Officer.

The quantities shown in the itemized proposal for the project are considered to be approximate only and are given as the basis for comparison of bids. The Department of Transportation may increase or decrease the quantity of any item or portion of the work as may be deemed necessary or expedient.

An increase or decrease in the quantity of an item will not be regarded as sufficient ground for an increase or decrease in the unit prices, nor in the time allowed for the completion of the work, except as provided for the contract.

Accompanying this bid is a bid bond secured by a corporate surety, or certified check payable to the order of the Department of Transportation, for five percent of the total bid price, which deposit is to be forfeited as liquidated damages in case this bid is accepted and the Bidder shall fail to provide the required payment and performance bonds with the Department of Transportation, under the condition of this proposal, within 14 calendar days after the written notice of award is received by him, as provided in the *Standard Specifications*; otherwise said deposit will be returned to the Bidder.



State Contract Officer

DocuSigned by:

Ronald Elton Davenport, Jr.

F81B6038A47A442...

12/07/2023

TABLE OF CONTENTS

**COVER SHEET
PROPOSAL SHEET**

PROJECT SPECIAL PROVISIONS

CONTRACTOR PREQUALIFICATION:..... G-1
 INTERESTED PARTIES LIST:..... G-2
 BUILD AMERICA, BUY AMERICA (BABA): G-3
 LIABILITY INSURANCE:..... G-3
 CONTRACT TIME AND LIQUIDATED DAMAGES: G-4
 INTERMEDIATE CONTRACT TIME NUMBER 1 AND LIQUIDATED DAMAGES: G-4
 INTERMEDIATE CONTRACT TIME NUMBER 2 AND LIQUIDATED DAMAGES: G-5
 RAILROAD GRADE CROSSING: G-6
 MAJOR CONTRACT ITEMS: G-6
 SPECIALTY ITEMS:..... G-6
 FUEL PRICE ADJUSTMENT:..... G-7
 STEEL PRICE ADJUSTMENT:..... G-8
 SCHEDULE OF ESTIMATED COMPLETION PROGRESS:..... G-19
 DISADVANTAGED BUSINESS ENTERPRISE: G-19
 CERTIFICATION FOR FEDERAL-AID CONTRACTS: G-32
 RESTRICTIONS ON ITS EQUIPMENT AND SERVICES:..... G-33
 USE OF UNMANNED AIRCRAFT SYSTEM (UAS): G-33
 EQUIPMENT IDLING GUIDELINES:..... G-33
 U.S. DEPARTMENT OF TRANSPORTATION HOTLINE: G-34
 MAINTENANCE OF THE PROJECT: G-34
 COOPERATION BETWEEN CONTRACTORS:..... G-35
 ELECTRONIC BIDDING:..... G-35
 AWARD LIMITS: G-36
 TWELVE MONTH GUARANTEE:..... G-36
 EROSION AND SEDIMENT CONTROL/STORMWATER CERTIFICATION:..... G-37
 PROCEDURE FOR MONITORING BORROW PIT DISCHARGE:..... G-42

 ROADWAY..... R-1

STANDARD SPECIAL PROVISIONS

AVAILABILITY FUNDS – TERMINATION OF CONTRACTS..... SSP-1
 NCDOT GENERAL SEED SPECIFICATION FOR SEED QUALITY SSP-2
 ERRATA..... SSP-5
 PLANT AND PEST QUARANTINES SSP-13
 TITLE VI AND NONDISCRIMINATION SSP-14
 MINORITY AND FEMALE EMPLOYMENT REQUIREMENTS SSP-22
 REQUIRED CONTRACT PROVISIONS FEDERAL-AID CONST. CONTRACTS SSP-25
 ON-THE-JOB TRAINING SSP-39
 MINIMUM WAGES SSP-42

UNIT PROJECT SPECIAL PROVISIONS

PAVEMENT MARKINGS.....	PM-1
TRAFFIC CONTROL	TC-1
EROSION CONTROL	EC-1
STRUCTURES (HI-0016).....	BP-1
STRUCTURES (HI-0017).....	BP1-1

PROPOSAL ITEM SHEET

ITEM SHEET(S)

PROJECT SPECIAL PROVISIONS**GENERAL****CONTRACTOR PREQUALIFICATION:**

(10-18-22)(Rev. 7-18-23)

102

SP1 G01

Revise the *2018 Standard Specifications* as follows:

Page 1-9, Subarticle 102-2(A)(1) Bidder Prequalification, lines 34-36, delete and replace the first sentence with the following:

Applicant shall submit a completed Department Prequalification Application and *Bidder Experience Questionnaire*, along with any additional supporting information requested by the Department, as noted in the application and experience questionnaire package.

Page 1-10, Subarticle 102-2(A) Bidder Prequalification, lines 30-31, delete and replace the first sentence with the following:

Prospective bidders shall obtain prequalification approval at least two business days prior to any letting in which they intend to submit a bid. It is recommended that the prospective bidder file all required statements and documents with the State Prequalifications Engineer no less than 4 weeks before a given letting.

Page 1-10, Subarticle 102-2(B) Purchase Order Bidder Prequalification, lines 34-39, delete and replace the title and first paragraph with the following:

(B) Purchase Order (PO) Prime Contractor Prequalification

Contractors who have been approved to be placed on the Prequalified Bidders' List as noted above may perform work for the Department as a Purchase Order (PO) Prime Contractor and need not apply further. However, Purchase Order (PO) Prime Contractors will not be placed on the Prequalified Bidders' List unless they submit through the prequalification process described above.

Page 1-9, Subarticle 102-2(B)(1) Purchase Order Bidder Prequalification, lines 40-42, delete and replace the first sentence with the following:

Applicant shall submit a completed Department Prequalification Application along with any additional supporting information requested by the Department, as noted in the application.

Page 1-11, Subarticle 102-2(B) Purchase Order Bidder Prequalification, lines 16-18, delete and replace the first sentence with the following:

Prospective bidders shall obtain prequalification approval at least two business days prior to any letting in which they intend to submit a bid. It is recommended that the applicant file all required statements and documents with the State Prequalifications Engineer no less than 4 weeks before a given bid opening for their bid to be considered.

Page 1-11, Subarticle 102-2(C) Subcontractor Prequalification, lines 22-26, delete and replace the first paragraph with the following:

Contractors who have been approved to be placed on the Prequalified Bidders' List or the Purchase Order (PO) Prime Contractor's List as noted above may perform work for the Department as a subcontractor and need not apply further. However, subcontractors will not be placed on the Prequalified List or the Purchase Order (PO) Prime Contractor's List unless they submit through the prequalification process described above.

Page 1-11, Subarticle 102-2(C)(1) Subcontractor Prequalification, lines 27-28, delete and replace the first sentence with the following:

Applicant shall submit a completed Department Prequalification Application along with any additional supporting information requested by the Department, as noted in the application.

Page 1-11, Subarticle 102-2(C) Subcontractor Prequalification, lines 44-45, delete and replace the first sentence with the following:

The subcontractor shall file all required statements and documents with the State Prequalifications Engineer no less than 4 weeks before beginning work.

Page 1-12, Subarticle 102-2(E) Renewal and Requalification, lines 38-40, delete and replace the first sentence with the following:

It is recommended that the renewing or requalifying firm file all required statements and documents with the State Prequalifications Engineer no less than 4 weeks before a given letting for their bid to be considered.

INTERESTED PARTIES LIST:

(6-21-22)(Rev. 7-19-22)

102

SP1 G02

Revise the *2018 Standard Specifications* as follows:

Page 1-12, Article 102-3 PROPOSALS AND PLAN HOLDER LISTS, lines 45-49, delete and replace with the following:

102-3 PROPOSALS AND INTERESTED PARTIES LIST

On Department projects advertised, the prospective bidder shall sign up on the *Interested Parties List* no later than one business day prior to the Letting day of that project, for which he intends to submit a bid. There is no cost for signing up on the *Interested Parties List* that can be found on the Department's website at connect.ncdot.gov/letting.

Page 1-12, Article 102-3 PROPOSALS AND PLAN HOLDER LISTS, lines 1-3, delete and replace the first sentence of the second paragraph with the following:

The proposal will state the location of the contemplated construction and show a schedule of contract items with the approximate quantity of each of these items for which bid prices are invited.

Page 1-14, Article 102-8 PREPARATION AND SUBMISSION OF BIDS, lines 30-31, delete and replace the first paragraph with the following:

Prior to submitting a bid on a project, the bidder shall sign up on the *Interested Parties List* in conformance with Article 102-3. The bidder shall submit a unit or lump sum price for every item in the proposal other than items that are authorized alternates to those items for which a bid price has been submitted.

BUILD AMERICA, BUY AMERICA (BABA):

(11-15-22)

106

SP1 G04

Revise the *2018 Standard Specifications* as follows:

Page 1-53, Article 106-1 GENERAL REQUIREMENTS, add the following after line 27:

(C) Build America, Buy America (BABA)

All manufactured products and construction materials permanently incorporated into any project must meet requirements of the Build America, Buy America (BABA) Act of the Infrastructure Investment and Jobs Act (IIJA). Before any material or product shown on the Department's Build America, Buy America (BABA) List is included for payment on a monthly estimate, the Contractor shall furnish the Engineer with a notarized certification certifying that the items conform to the BABA Act. The Department's Build America Buy America (BABA) List can be found on the Department's website.

<https://connect.ncdot.gov/letting/LetCentral/NCDOT%20BABA%20Materials%20List.pdf>

Each purchase order issued by the Contractor or a subcontractor for items on the BABA List to be permanently incorporated into any project shall contain in bold print a statement advising the supplier that the manufactured products and construction materials must be produced in the United States of America. The Contractor and all affected subcontractors shall maintain a separate file for BABA List items so that verification of the Contractor's efforts to purchase items produced in the United States can readily be verified by an authorized representative of the Department or the Federal Highway Administration (FHWA).

LIABILITY INSURANCE:

(5-16-23)

107

SP1 G05

Revise the *2018 Standard Specifications* as follows:

Page 1-64, Article 107-15 LIABILITY INSURANCE, replace the first sentence with the following:

The Contractor shall at its sole cost and expense obtain and furnish to the Department an original standard Association for Cooperative Operations Research and Development (ACORD) certificate of liability insurance evidencing commercial general liability with a limit for bodily injury and property damage in the amount of \$5,000,000 per occurrence and \$5,000,000 general aggregate, covering the Contractor from claims or damages for bodily injury, personal injury, or

for property damages that may arise from operating under the contract by the employees and agents of the Contractor.

CONTRACT TIME AND LIQUIDATED DAMAGES:

(7-1-95) (Rev. 12-18-07)

108

SP1 G10 A

The date of availability for this contract is **January 29, 2024**.

The completion date for this contract is **July 1, 2026**.

Except where otherwise provided by the contract, observation periods required by the contract will not be a part of the work to be completed by the completion date and/or intermediate contract times stated in the contract. The acceptable completion of the observation periods that extend beyond the final completion date shall be a part of the work covered by the performance and payment bonds.

The liquidated damages for this contract are **Two Thousand Dollars (\$ 2,000.00)** per calendar day.

INTERMEDIATE CONTRACT TIME NUMBER 1 AND LIQUIDATED DAMAGES:

(2-20-07)

108

SP1 G14 A

The Contractor shall complete the required work of installing, maintaining, and removing the traffic control devices for lane closures and restoring traffic to the existing traffic pattern. The Contractor shall not close or narrow a lane of traffic on **the following roads** during the following time restrictions:

DAY AND TIME RESTRICTIONS

US 74 (from Memorial Day to Labor Day of any year)

From Friday at 12:00 PM (noon) to the following Monday at 12:00 AM (midnight)

Any Other Road

Monday thru Friday, 6:00 AM to 9:00 AM and 3:00 PM to 6:00 PM

In addition, the Contractor shall not close or narrow a lane of traffic on **Any Road**, detain and/or alter the traffic flow on or during holidays, holiday weekends, special events, or any other time when traffic is unusually heavy, including the following schedules:

HOLIDAY AND HOLIDAY WEEKEND LANE CLOSURE RESTRICTIONS

1. For **unexpected occurrence** that creates unusually high traffic volumes, as directed by the Engineer.
2. For **New Year's Day**, between the hours of **6:00 AM** December 31st and **6:00 PM** January 2nd. If New Year's Day is on a Friday, Saturday, Sunday or Monday, then until **6:00 PM** the following Tuesday.
3. For **Easter**, between the hours of **6:00 AM** Thursday and **6:00 PM** Monday.
4. For **Memorial Day**, between the hours of **6:00 AM** Friday and **6:00 PM** Tuesday.

5. For **Independence Day**, between the hours of **6:00 AM** the day before Independence Day and **6:00 PM** the day after Independence Day.

If **Independence Day** is on a Friday, Saturday, Sunday or Monday, then between the hours of **6:00 AM** the Thursday before Independence Day and **6:00 PM** the Tuesday after Independence Day.

6. For **Labor Day**, between the hours of **6:00 AM** Friday and **6:00 PM** Tuesday.
7. For **Thanksgiving**, between the hours of **6:00 AM** Tuesday and **6:00 PM** Monday.
8. For **Christmas**, between the hours of **6:00 AM** the Friday before the week of Christmas Day and **6:00 PM** the following Tuesday after the week of Christmas Day.

Holidays and holiday weekends shall include New Year's, Easter, Memorial Day, Independence Day, Labor Day, Thanksgiving, and Christmas. The Contractor shall schedule his work so that lane closures will not be required during these periods, unless otherwise directed by the Engineer.

The time of availability for this intermediate contract work shall be the time the Contractor begins to install all traffic control devices for lane closures according to the time restrictions listed herein.

The completion time for this intermediate contract work shall be the time the Contractor is required to complete the removal of all traffic control devices for lane closures according to the time restrictions stated above and place traffic in the existing traffic pattern.

The liquidated damages are **Two Hundred Fifty Dollars (\$ 250.00)** per hour.

INTERMEDIATE CONTRACT TIME NUMBER 2 AND LIQUIDATED DAMAGES:

(2-20-07) (Rev. 10-15-13)

108

SP1 G14 E

The Contractor shall complete the required work of installing, maintaining and removing the traffic control devices for road closures and restoring traffic to the existing traffic pattern. The Contractor shall not close **US 74 Eastbound (Bridge #770454)** or **US 74 Westbound (Bridge #770455)** during the following time restrictions:

DAY AND TIME RESTRICTIONS

Monday thru Thursday, from 6:00 AM to 9:00 PM

And from Friday at 6:00 AM to Sunday at 9:00 PM

The maximum allowable time for a **directional closure for post tensioning strand replacement on any bridge** is **thirty (30) minutes** for **US 74 Eastbound and/or US 74 Westbound**. The Contractor shall reopen the travel lanes to traffic until any resulting traffic queue is depleted.

The time of availability for this intermediate contract time will be the time the Contractor begins to install traffic control devices required for the road closures according to the time restrictions stated herein.

The completion time for this intermediate contract time will be the time the Contractor is required to complete the removal of traffic control devices required for the road closures according to the time restrictions stated herein and restore traffic to the existing traffic pattern.

The liquidated damages are **Two Hundred Fifty Dollars (\$ 250.00)** per fifteen (15) minute time period.

RAILROAD GRADE CROSSING:

(7-1-95) (Rev. 10-20-20)

107-9

SP1 G17R

When the use of slow moving or stopped equipment is required over at-grade railroad crossings, the contractor shall contact the appropriate track owner to gain Right of Entry. The contractor shall be responsible for ascertaining and contacting the railroad track owner.

No separate payment will be made for conforming with the requirements of this Special Provision. Please contact the Resident Engineer or the Surfaces and Encroachment manager with the Rail Division with any questions pertaining to the Right of Entry at 919-707-4132 or mmclamb@ncdot.gov.

MAJOR CONTRACT ITEMS:

(2-19-02)

104

SP1 G28

The following listed items are the major contract items for this contract (see Article 104-5 of the *2018 Standard Specifications*):

Line #	Description
17	Aggregate Shoulder Borrow
24	Asphalt Concrete Base Course, Type B25.0C
25	Asphalt Concrete Surface Course, Type S9.5C

SPECIALTY ITEMS:

(7-1-95)(Rev. 7-20-21)

108-6

SP1 G37

Items listed below will be the specialty items for this contract (see Article 108-6 of the *2018 Standard Specifications*).

Line #	Description
35-44	Guardrail
45-47	Fencing
48-58	Signing
68-72,78	Long-Life Pavement Markings
79	Permanent Pavement Markers
80-87	Erosion Control

FUEL PRICE ADJUSTMENT:

(11-15-05) (Rev. 11-15-22)

109-8

SP1 G43

Revise the *2018 Standard Specifications* as follows:

Page 1-87, Article 109-8, Fuel Price Adjustments, add the following:

The base index price for DIESEL #2 FUEL is \$ **3.1046** per gallon. Where any of the following are included as pay items in the contract, they will be eligible for fuel price adjustment.

The pay items and the fuel factor used in calculating adjustments to be made will be as follows:

Description	Units	Fuel Usage Factor Diesel
Unclassified Excavation	Gal/CY	0.29
Borrow Excavation	Gal/CY	0.29
Class IV Subgrade Stabilization	Gal/Ton	0.55
Aggregate Base Course	Gal/Ton	0.55
Sub-Ballast	Gal/Ton	0.55
Erosion Control Stone	Gal/Ton	0.55
Rip Rap, Class	Gal/Ton	0.55
Asphalt Concrete Base Course, Type _____	Gal/Ton	0.90 or 2.90
Asphalt Concrete Intermediate Course, Type _____	Gal/Ton	0.90 or 2.90
Asphalt Concrete Surface Course, Type _____	Gal/Ton	0.90 or 2.90
Open-Graded Asphalt Friction Course	Gal/Ton	0.90 or 2.90
Permeable Asphalt Drainage Course, Type _____	Gal/Ton	0.90 or 2.90
Sand Asphalt Surface Course, Type _____	Gal/Ton	0.90 or 2.90
Ultra-thin Bonded Wearing Course	Gal/Ton	0.90 or 2.90
Aggregate for Cement Treated Base Course	Gal/Ton	0.55
Portland Cement for Cement Treated Base Course	Gal/Ton	0.55
> 11" Portland Cement Concrete Pavement	Gal/SY	0.327
Concrete Shoulders Adjacent to > 11" Pavement	Gal/SY	0.327
9" to 11" Portland Cement Concrete Pavement	Gal/SY	0.272
Concrete Shoulders Adjacent to 9" to 11" Pavement	Gal/SY	0.272
< 9" Portland Cement Concrete Pavement	Gal/SY	0.245
Concrete Shoulders Adjacent to < 9" Pavement	Gal/SY	0.245

For the asphalt items noted in the chart as eligible for fuel adjustments, the bidder may include the *Fuel Usage Factor Adjustment Form* with their bid submission if they elect to use the fuel usage factor. The *Fuel Usage Factor Adjustment Form* is found at the following link:

<https://connect.ncdot.gov/letting/LetCentral/Fuel%20Usage%20Factor%20Adjustment%20Form%20-%20Starting%20Nov%202022%20Lettings.pdf>

Select either 2.90 Gal/Ton fuel factor or 0.90 Gal/Ton fuel factor for each asphalt line item on the *Fuel Usage Factor Adjustment Form*. The selected fuel factor for each asphalt item will remain in effect for the duration of the contract.

Failure to complete the *Fuel Usage Factor Adjustment Form* will result in using 2.90 gallons per ton as the Fuel Usage Factor for Diesel for the asphalt items noted above. The contractor will not be permitted to change the Fuel Usage Factor after the bids are submitted.

STEEL PRICE ADJUSTMENT:

(4-19-22)(Rev. 12-19-23)

SP1 G47

Description and Purpose

Steel price adjustments will be made to the payments due the Contractor for items as defined herein that are permanently incorporated into the work, when the price of raw steel mill products utilized on the contract have fluctuated. The Department will adjust monthly progress payments up or down as appropriate for cost changes in steel according to this provision.

Eligible Items

The list of eligible bid items for steel price adjustment can be found on the Departments website at the following address:

<https://connect.ncdot.gov/letting/LetCentral/Eligible%20Bid%20Items%20for%20Steel%20Price%20Adjustment.xlsx>

Nuts, bolts, anchor bolts, rebar chairs, connecting bands and other miscellaneous hardware associated with these items shall not be included in the price adjustment.

Adjustments will only be made for fluctuations in the material cost of the steel used in the above products as specified in the Product Relationship Table below. The producing mill is defined as the source of steel product before any fabrication has occurred (e.g., coil, plate, rebar, hot rolled shapes, etc.). No adjustment will be made for changes in the cost of fabrication, coating, shipping, storage, etc.

No steel price adjustments will be made for any products manufactured from steel having an adjustment date, as defined by the Product Relationship Table below, prior to the letting date.

Bid Submittal Requirements

The successful bidder, within 14 calendar days after the notice of award is received by him, shall provide the completed Form SPA-1 to the Department (State Contract Officer or Division Contract Engineer) along with the payment bonds, performance bonds and contract execution signature sheets in a single submittal. If Form SPA-1 is not included in the same submittal as the payment bonds, performance bonds and contract execution signature sheets, the Contractor will not be eligible for any steel price adjustment for any item in the contract for the life of the contract. Form SPA-1 can be found on the Department's website at the following address:

<https://connect.ncdot.gov/letting/LetCentral/Form%20SPA-1.xlsm>

The Contractor shall provide Form SPA-1 listing the Contract Line Number, (with corresponding Item Number, Item Description, and Category) for the steel products they wish to have an adjustment calculated. Only the contract items corresponding to the list of eligible item numbers

for steel price adjustment may be entered on Form SPA-1. The Contractor may choose to have steel price adjustment applied to any, all, or none of the eligible items. However, the Contractor's selection of items for steel price adjustment or non-selection (non-participation) may not be changed once Form SPA-1 has been received by the Department. Items the Bidder chooses for steel price adjustment must be designated by writing the word "Yes" in the column titled "Option" by each Pay Item chosen for adjustment. Should the bidder elect an eligible steel price item, the entire quantity of the line item will be subject to the price adjustment for the duration of the Contract. The Bidder's designations on Form SPA-1 must be written in ink or typed and signed by the Bidder (Prime Contractor) to be considered complete. Items not properly designated, designated with "No", or left blank on the Bidder's Form SPA-1 will automatically be removed from consideration for adjustment. No steel items will be eligible for steel price adjustment on this Project if the Bidder fails to return Form SPA-1 in accordance with this provision.

Establishing the Base Price

The Department will use a blend of monthly average prices as reported from the Fastmarkets platform to calculate the monthly adjustment indices (BI and MI). This data is typically available on the first day of the month for the preceding month. The indices will be calculated by the Department for the different categories found on the Product Relationship Table below. For item numbers that include multiple types of steel products, the category listed for that item number will be used for adjusting each steel component.

The bidding index for Category 1 Steel items is **\$ 41.63** per hundredweight.

The bidding index for Category 2 Steel items is **\$ 68.87** per hundredweight.

The bidding index for Category 3 Steel items is **\$ 62.44** per hundredweight.

The bidding index for Category 4 Steel items is **\$ 40.07** per hundredweight.

The bidding index for Category 5 Steel items is **\$ 53.69** per hundredweight.

The bidding index for Category 6 Steel items is **\$ 62.82** per hundredweight.

The bidding index for Category 7 Steel items is **\$ 42.94** per hundredweight.

The bidding index represents a selling price of steel based on Fastmarkets data for the month of **October 2023**.

MI = Monthly Index. – in Dollars (\$) per hundredweight (CWT). Use the adjustment indices from the month the steel was shipped from the producing mill, received on the project, or member cast as defined in the Product Relationship Table.

BI = Bidding Index. - in Dollars (\$) per hundredweight (CWT). Use the adjustment indices as listed in the proposal.

<i>Steel Product (Title)</i>	BI, MI*	Adjustment Date for MI	Category
Reinforcing Steel, Bridge Deck, and SIP Forms	Based on one or more Fastmarkets indices	Delivery Date from Producing Mill	1
Structural Steel and Encasement Pipe	Based on one or more Fastmarkets indices	Delivery Date from Producing Mill	2
Steel H-Piles, Soldier Pile Walls	Based on one or more Fastmarkets indices	Delivery Date from Producing Mill	3
Guardrail Items and Pipe Piles	Based on one or more Fastmarkets indices	Material Received Date**	4

Fence Items	Based on one or more Fastmarkets indices	Material Received Date**	5
Overhead Sign Assembly, Signal Poles, High Mount Standards	Based on one or more Fastmarkets indices	Material Received Date**	6
Prestressed Concrete Members	Based on one or more Fastmarkets indices	Cast Date of Member	7

Submit documentation to the Engineer for all items listed in the Contract for which the Contractor is requesting a steel price adjustment.

Submittal Requirements

The items in categories 1,2, and 3, shall be specifically stored, labeled, or tagged, recognizable by color marking, and identifiable by Project for inspection and audit verification immediately upon arrival at the fabricator.

Furnish the following documentation for all steel products to be incorporated into the work and documented on Form SPA-2, found on the Departments website at the following address:

<https://connect.ncdot.gov/projects/construction/Construction%20Forms/Form%20SPA-2.xlsx>

Submit all documentation to the Engineer prior to incorporation of the steel into the completed work. The Department will withhold progress payments for the affected contract line item if the documentation is not provided and at the discretion of the Engineer the work is allowed to proceed. Progress payments will be made upon receipt of the delinquent documentation.

Step 1 (Form SPA -2)

Utilizing Form SPA-2, submit separate documentation packages for each line item from Form SPA-1 for which the Contractor opted for a steel price adjustment. For line items with multiple components of steel, each component should be listed separately. Label each SPA-2 documentation package with a unique number as described below.

- a. Documentation package number: (Insert the contract line-item) - (Insert sequential package number beginning with "1").
Example: 412 - 1,
412 - 2,
424 - 1,
424 - 2,
424 - 3, etc.
- b. The steel product quantity in pounds
 - i. The following sources should be used, in declining order of precedence, to determine the weight of steel/iron, based on the Engineers decision:
 1. Department established weights of steel/iron by contract pay item per pay unit;
 2. Approved Shop Drawings;
 3. Verified Shipping Documents;
 4. Contract Plans;

5. Standard Drawing Sheets;
 6. Industry Standards (i.e., AISC Manual of Steel Construction, AWWA Standards, etc.); and
 7. Manufacture's data.
- ii. Any item requiring approved shop drawings shall have the weights of steel calculated and shown on the shop drawings or submitted and certified separately by the fabricator.
 - c. The date the steel product, subject to adjustment, was shipped from the producing mill (Categories 1-3), received on the project (Categories 4-6), or casting date (Category 7).

Step 2 (Monthly Calculator Spreadsheet)

For each month, upon the incorporation of the steel product into the work, provide the Engineer the following:

- 1) Completed NCDOT Steel Price Adjustment Calculator Spreadsheet, summarizing all the steel submittal packages (Form SPA-2) actually incorporated into the completed work in the given month.
 - a. Contract Number
 - b. Bidding Index Reference Month
 - c. Contract Completion Date or Revised Completion Date
 - d. County, Route, and Project TIP information
 - e. Item Number
 - f. Line-Item Description
 - g. Submittal Number from Form SPA-2
 - h. Adjustment date
 - i. Pounds of Steel
- 2) An affidavit signed by the Contractor stating the documentation provided in the NCDOT Steel Price Adjustment Calculator Spreadsheet is true and accurate.

Price Adjustment Conditions

Download the Monthly Steel Adjustment Spreadsheet with the most current reference data from the Department's website each month at the following address:

<https://connect.ncdot.gov/projects/construction/Construction%20Forms/Form%20SPA-3%20NCDOT%20Steel%20Price%20Adjustment%20Calculator.xlsx>

If the monthly Fastmarkets data is not available, the data for the most recent immediately preceding month will be used as the basis for adjustment.

Price Adjustment Calculations

The price adjustment will be determined by comparing the percentage of change in index value listed in the proposal (BI) to the monthly index value (MI). (See included sample examples). Weights and date of shipment must be documented as required herein. The final price adjustment dollar value will be determined by multiplying this percentage increase or decrease in the index by the represented quantity of steel incorporated into the work, and the established bidding index (BI) subject to the limitations herein.

Price increase/decrease will be computed as follows:

$$\text{SPA} = ((\text{MI}/\text{BI}) - 1) * \text{BI} * (\text{Q}/100)$$

Where;

SPA = Steel price adjustment in dollars

MI = Monthly Shipping Index. – in Dollars (\$) per hundredweight (CWT). Use the adjustment indices from the month the steel was shipped from the producing mill, received on the project, or member cast as defined in the Product Relationship Table.

BI = Bidding Index. - in Dollars (\$) per hundredweight (CWT). Use the adjustment indices as listed in the proposal.

Q = Quantity of steel, product, pounds actually incorporated into the work as documented by the Contractor, or Design Build Team and verified by the Engineer.

Calculations for price adjustment shall be shown separate from the monthly progress estimate and will not be included in the total cost of work for determination of progress or for extension of Contract time in accordance with Subarticle 108-10(B)(1).

Any apparent attempt to unbalance bids in favor of items subject to price adjustment may result in rejection of the bid proposal.

Adjustments will be paid or charged to the Contractor only. Any Contractor receiving an adjustment under this provision shall distribute the proper proportional part of such adjustments to the subcontractor who performed the applicable work.

Delays to the work caused by steel shortages may be justification for a Contract time extension but will not constitute grounds for claims for standby equipment, extended office overhead, or other costs associated with such delays.

If an increase in the steel material price is anticipated to exceed 50% of the original quoted price, the contractor must notify the Department within 7 days prior to purchasing the material. Upon receipt of such notification, the Department will direct the Contractor to either (1) proceed with the work or (2) suspend the work and explore the use of alternate options.

If the decrease in the steel material exceeds 50% of the original quoted price, the contractor may submit to the Department additional market index information specific to the item in question to dispute the decrease. The Department will review this information and determine if the decrease is warranted.

When the steel product adjustment date, as defined in the Product Relationship Table, is after the approved contract completion date, the steel price adjustments will be based on the lesser value of either the MI for the month of the approved contract completion date or the MI for the actual adjustment date.

If the price adjustment is based on estimated material quantities for that time, and a revision to the total material quantity is made in a subsequent or final estimate, an appropriate adjustment will be made to the price adjustment previously calculated. The adjustment will be based on the

same indices used to calculate the price adjustment which is being revised. If the adjustment date of the revised material quantity cannot be determined, the adjustment for the quantity in question, will be based on the indices utilized to calculate the steel price adjustment for the last initial documentation package submission, for the steel product subject to adjustment, that was incorporated into the particular item of work, for which quantities are being finalized.

Example: Structural steel for a particular bridge was provided for in three different shipments with each having a different mill shipping date. The quantity of structural steel actually used for the bridge was calculated and a steel price adjustment was made in a progress payment. At the conclusion of the work an error was found in the plans of the final quantity of structural steel used for the bridge. The quantity to be adjusted cannot be directly related to any one of the three mill shipping dates. The steel price adjustment for the quantity in question would be calculated using the indices that were utilized to calculate the steel price adjustment for the quantity of structural steel represented by the last initial structural steel documentation package submission. The package used will be the one with the greatest sequential number.

Extra Work/Force Account:

When steel products, as specified herein, are added to the contract as extra work, in accordance with the provisions of Article 104-7 or 104-3, the Engineer will determine and specify in the supplemental agreement, the need for application of steel price adjustments on a case-by-case basis. No steel price adjustments will be made for any products manufactured from steel having an adjustment date prior to the supplemental agreement execution date. Price adjustments will be made as provided herein, except the Bidding Index will be based on the month in which the supplemental agreement pricing was executed.

For work performed on force account basis, reimbursement of actual material costs, along with the specified overhead and profit markup, will be considered to include full compensation for the current cost of steel and no steel price adjustments will be made.

Examples Form SPA-2

Steel Price Adjustment Submission Form

Contract Number C203394 Bid Reference Month January 2019

Submittal Date 8/31/2019

Contract Line Item 237

Line Item Description APPROX....LBS Structural Steel

Sequential Submittal Number 2

Supplier	Description of material	Location information	Quantity in lbs.	Adjustment Date
XYZ mill	Structural Steel	Structure 3, Spans A-C	1,200,000	May 4, 2020
ABC distributing	Various channel & angle shapes	Structure 3 Spans A-C	35,000	July 14, 2020
		Total Pounds of Steel	1,235,000	

Note: Attach the following supporting documentation to this form.

- Bill of Lading to support the shipping dates
- Supporting information for weight documentation (e.g., Pay item reference, Shop drawings, shipping documents, Standards Sheets, industry standards, or manufacturer's data)

By providing this data under my signature, I attest to the accuracy of and validity of the data on this form and certify that no deliberate misrepresentation in any manner has occurred.

Printed Name

Signature

Examples Form SPA-2**Steel Price Adjustment Submission Form**Contract Number C203394 Bid Reference Month January 2019Submittal Date August 31, 2019Contract Line Item 237Line Item Description SUPPORT, OVRHD SIGN STR -DFEB – STA 36+00Sequential Submittal
Number 2

Supplier	Description of material	Location information	Quantity in lbs.	Adjustment Date
XYZ mill	Tubular Steel (Vertical legs)	<u>-DFEB – STA 36+00</u>	12000	December 11, 2021
PDQ Mill	4" Tubular steel (Horizontal legs)	<u>-DFEB – STA 36+00</u>	5900	December 11, 2021
ABC distributing	Various channel & angle shapes (see quote)	<u>-DFEB – STA 36+00</u>	1300	December 11, 2021
	Catwalk assembly	<u>-DFEB – STA 36+00</u>	2000	December 11, 2021
Nucor	Flat plate	<u>-DFEB – STA 36+00</u>	650	December 11, 2021
		Total Pounds of Steel	21,850	

Note: Attach the following supporting documentation to this form.

- Bill of Lading to support the shipping dates
- Supporting information for weight documentation (e.g., Pay item reference, Shop drawings, shipping documents, Standards Sheets, industry standards, or manufacturer's data)

By providing this data under my signature, I attest to the accuracy of and validity of the data on this form and certify that no deliberate misrepresentation in any manner has occurred.

Printed Name

Signature

Price Adjustment Sample Calculation (increase)

Project bid on September 17, 2019

Line Item 635 "Structural Steel" has a plan quantity of 2,717,000 lbs.

Bidding Index for Structural Steel (Category 2) in the proposal was \$36.12/CWT = BI

450,000 lbs. of Structural Steel for Structure 2 at Station 44+08.60 were shipped to fabricator from the producing mill in same month, May 2021.

Monthly Index for Structural Steel (Category 2) for May 2021 was \$64.89/CWT = MI

The Steel Price Adjustment formula is as follows:

$$\text{SPA} = ((\text{MI} / \text{BI}) - 1) * \text{BI} * (\text{Q} / 100)$$

Where; SPA = Steel price adjustment in dollars

BI = Bidding Index – in dollars (\$) per hundredweight (CWT). Use the adjustment indices as listed in the proposal.

MI = Mill Shipping Index – in dollars (\$) per hundredweight (CWT). Use the adjustment indices from the month the steel was shipped from the producing mill, received on the project, or member cast as defined in the Product Relationship Table.

Q = Quantity of steel product, in pounds (lbs.) actually incorporated into the work as documented by the Contractor, or Design Build Team and verified by the Engineer.

$$\text{BI} = \$36.12 / \text{CWT}$$

$$\text{MI} = \$64.89 / \text{CWT}$$

$$\% \text{ change} = ((\text{MI} / \text{BI}) - 1) = (\$64.89 / \$36.12 - 1) = (1.79651 - 1) = 0.79651162791$$

$$\text{Q} = 450,000 \text{ lbs.}$$

$$\text{SPA} = 0.79651162791 \times \$36.12 \times (450,000 / 100)$$

$$\text{SPA} = 0.79651162791 * \$36.12 * 4,500$$

$$\text{SPA} = \$129,465 \text{ pay adjustment to Contractor for Structural Steel (Structure 2 at Station 44+08.60)}$$

Price Adjustment Sample Calculation (decrease)

Project bid on December 18, 2018

Line Item 635 Structural Steel has a plan quantity of 2,717,000 lbs.

Bidding Index for Structural Steel (Category 2) in the proposal was \$46.72/CWT = BI

600,000 lbs. of Structural Steel for Structure 1 at Station 22+57.68 were shipped to fabricator from the producing mill in same month, August 2020.

Monthly Index for Structural Steel (Category 2) for August 2020 was \$27.03/CWT = MI

The Steel Price Adjustment formula is as follows:

$$\text{SPA} = ((\text{MI} / \text{BI}) - 1) * \text{BI} * (\text{Q} / 100)$$

Where; SPA = Steel price adjustment in dollars

BI = Bidding Index – in dollars (\$) per hundredweight (CWT). Use the adjustment indices as listed in the proposal.

MI = Mill Shipping Index – in dollars (\$) per hundredweight (CWT). Use the adjustment indices from the month the steel was shipped from the producing mill, received on the project, or member cast as defined in the Product Relationship Table.

Q = Quantity of steel product, in pounds (lbs.) actually incorporated into the work as documented by the Contractor, or Design Build Team and verified by the Engineer.

$$\text{BI} = \$46.72 / \text{CWT}$$

$$\text{MI} = \$27.03 / \text{CWT}$$

$$\% \text{ change} = ((\text{MI} / \text{BI}) - 1) = (\$27.03 / \$46.72 - 1) = (0.57855 - 1) = -0.421446917808$$

$$\text{Q} = 600,000 \text{ lbs.}$$

$$\text{SPA} = -0.421446917808 * \$46.72 * (600,000 / 100)$$

$$\text{SPA} = -0.421446917808 * \$46.72 * 6,000$$

$$\text{SPA} = \$ 118,140.00 \text{ Credit to the Department for Structural Steel (Structure 1 at Station 22+57.68)}$$

Price Adjustment Sample Calculation (increase)

Project bid on July 16, 2020

Line Item 614 Reinforced Concrete Deck Slab has a plan quantity of 241974 lbs.

Bidding Index Reference Month was May 2020. Bidding Index for Reinforced Concrete Deck Slab (Category 1) in the proposal was \$29.21/CWT = BI

51,621 lbs. of reinforcing steel and 52,311 lbs. of epoxy coated reinforcing steel for Structure 2 at Station 107+45.55 -L- was shipped to fabricator from the producing mill in same month, May 2021.

Monthly Index for Reinforced Concrete Deck Slab (Category 1) for May 2021 was \$43.13/CWT = MI

The Steel Price Adjustment formula is as follows:

$$\text{SPA} = ((\text{MI} / \text{BI}) - 1) * \text{BI} * (\text{Q} / 100)$$

Where; SPA = Steel price adjustment in dollars

BI = Bidding Index – in dollars (\$) per hundredweight (CWT). Use the adjustment indices as listed in the proposal.

MI = Mill Shipping Index – in dollars (\$) per hundredweight (CWT). Use the adjustment indices from the month the steel was shipped from the producing mill, received on the project, or member cast as defined in the Product Relationship Table.

Q = Quantity of steel product, in pounds (lbs.) actually incorporated into the work as documented by the Contractor, or Design Build Team and verified by the Engineer.

$$\text{BI} = \$29.21 / \text{CWT}$$

$$\text{MI} = \$43.13 / \text{CWT}$$

$$\% \text{ change} = ((\text{MI} / \text{BI}) - 1) = (\$43.13 / \$29.21 - 1) = (1.47655 - 1) = 0.47654912701$$

$$\text{Q} = 103932 \text{ lbs.}$$

$$\text{SPA} = 0.47654912701 * \$29.21 * (103,932 / 100)$$

$$\text{SPA} = 0.47654912701 * \$29.21 * 1,039.32$$

SPA = \$14,467.33 Pay Adjustment to Contractor for Reinforced Concrete Deck Slab (Category 1) at Station 107+45.55 -L-

SCHEDULE OF ESTIMATED COMPLETION PROGRESS:

(7-15-08) (Rev. 6-20-23)

108-2

SP1 G58

The Contractor's attention is directed to the Standard Special Provision entitled *Availability of Funds Termination of Contracts* included elsewhere in this proposal. The Department of Transportation's schedule of estimated completion progress for this project as required by that Standard Special Provision is as follows:

	<u>Fiscal Year</u>	<u>Progress (% of Dollar Value)</u>
2024	(7/01/23 - 6/30/24)	28% of Total Amount Bid
2025	(7/01/24 - 6/30/25)	49% of Total Amount Bid
2026	(7/01/25 - 6/30/26)	23% of Total Amount Bid

The Contractor shall also furnish his own progress schedule in accordance with Article 108-2 of the *2018 Standard Specifications*. Any acceleration of the progress as shown by the Contractor's progress schedule over the progress as shown above shall be subject to the approval of the Engineer.

DISADVANTAGED BUSINESS ENTERPRISE:

(10-16-07)(Rev. 8-17-21)

102-15(J)

SP1 G61

Description

The purpose of this Special Provision is to carry out the U.S. Department of Transportation's policy of ensuring nondiscrimination in the award and administration of contracts financed in whole or in part with Federal funds. This provision is guided by 49 CFR Part 26.

Definitions

Additional DBE Subcontractors - Any DBE submitted at the time of bid that will not be used to meet the DBE goal. No submittal of a Letter of Intent is required.

Committed DBE Subcontractor - Any DBE submitted at the time of bid that is being used to meet the DBE goal by submission of a Letter of Intent. Or any DBE used as a replacement for a previously committed DBE firm.

Contract Goal Requirement - The approved DBE participation at time of award, but not greater than the advertised contract goal.

DBE Goal - A portion of the total contract, expressed as a percentage, that is to be performed by committed DBE subcontractor(s).

Disadvantaged Business Enterprise (DBE) - A firm certified as a Disadvantaged Business Enterprise through the North Carolina Unified Certification Program.

Goal Confirmation Letter - Written documentation from the Department to the bidder confirming the Contractor's approved, committed DBE participation along with a listing of the committed DBE firms.

Manufacturer - A firm that operates or maintains a factory or establishment that produces on the premises, the materials or supplies obtained by the Contractor.

Regular Dealer - A firm that owns, operates, or maintains a store, warehouse, or other establishment in which the materials or supplies required for the performance of the contract are bought, kept in stock, and regularly sold to the public in the usual course of business. A regular dealer engages in, as its principal business and in its own name, the purchase and sale or lease of the products in question. A regular dealer in such bulk items as steel, cement, gravel, stone, and petroleum products need not keep such products in stock, if it owns and operates distribution equipment for the products. Brokers and packagers are not regarded as manufacturers or regular dealers within the meaning of this section.

Replacement / Substitution – A full or partial reduction in the amount of work subcontracted to a committed (or an approved substitute) DBE firm.

North Carolina Unified Certification Program (NCUCP) - A program that provides comprehensive services and information to applicants for DBE certification, such that an applicant is required to apply only once for a DBE certification that will be honored by all recipients of USDOT funds in the state and not limited to the Department of Transportation only. The Certification Program is in accordance with 49 CFR Part 26.

United States Department of Transportation (USDOT) - Federal agency responsible for issuing regulations (49 CFR Part 26) and official guidance for the DBE program.

Forms and Websites Referenced in this Provision

DBE Payment Tracking System - On-line system in which the Contractor enters the payments made to DBE subcontractors who have performed work on the project.
<https://apps.dot.state.nc.us/Vendor/PaymentTracking/>

DBE-IS Subcontractor Payment Information - Form for reporting the payments made to all DBE firms working on the project. This form is for paper bid projects only.
<https://connect.ncdot.gov/business/Turnpike/Documents/Form%20DBE-IS%20Subcontractor%20Payment%20Information.pdf>

RF-1 DBE Replacement Request Form - Form for replacing a committed DBE.
<http://connect.ncdot.gov/projects/construction/Construction%20Forms/DBE%20MBE%20WBE%20Replacement%20Request%20Form.pdf>

SAF Subcontract Approval Form - Form required for approval to sublet the contract.
<http://connect.ncdot.gov/projects/construction/Construction%20Forms/Subcontract%20Approval%20Form%20Rev.%202012.zip>

JC-1 Joint Check Notification Form - Form and procedures for joint check notification. The form acts as a written joint check agreement among the parties providing full and prompt disclosure of the expected use of joint checks.
<http://connect.ncdot.gov/projects/construction/Construction%20Forms/Joint%20Check%20Notification%20Form.pdf>

Letter of Intent - Form signed by the Contractor and the DBE subcontractor, manufacturer or regular dealer that affirms that a portion of said contract is going to be performed by the signed DBE for the estimated amount (based on quantities and unit prices) listed at the time of bid.

<http://connect.ncdot.gov/letting/LetCentral/Letter%20of%20Intent%20to%20Perform%20as%20a%20Subcontractor.pdf>

Listing of DBE Subcontractors Form - Form for entering DBE subcontractors on a project that will meet this DBE goal. This form is for paper bids only.

[http://connect.ncdot.gov/municipalities/Bid%20Proposals%20for%20LGA%20Content/08%20DBE%20Subcontractors%20\(Federal\).docx](http://connect.ncdot.gov/municipalities/Bid%20Proposals%20for%20LGA%20Content/08%20DBE%20Subcontractors%20(Federal).docx)

Subcontractor Quote Comparison Sheet - Spreadsheet for showing all subcontractor quotes in the work areas where DBEs quoted on the project. This sheet is submitted with good faith effort packages.

<http://connect.ncdot.gov/business/SmallBusiness/Documents/DBE%20Subcontractor%20Quote%20Comparison%20Example.xls>

DBE Goal

The following DBE goal for participation by Disadvantaged Business Enterprises is established for this contract:

Disadvantaged Business Enterprise **6.0 %**

- (A) *If the DBE goal is more than zero*, the Contractor shall exercise all necessary and reasonable steps to ensure that DBEs participate in at least the percent of the contract as set forth above as the DBE goal.
- (B) *If the DBE goal is zero*, the Contractor shall make an effort to recruit and use DBEs during the performance of the contract. Any DBE participation obtained shall be reported to the Department.

Directory of Transportation Firms (Directory)

Real-time information is available about firms doing business with the Department and firms that are certified through NCUCP in the Directory of Transportation Firms. Only firms identified in the Directory as DBE certified shall be used to meet the DBE goal. The Directory can be found at the following link. [https:// www.ebs.nc.gov/VendorDirectory/default.html](https://www.ebs.nc.gov/VendorDirectory/default.html)

The listing of an individual firm in the directory shall not be construed as an endorsement of the firm's capability to perform certain work.

Listing of DBE Subcontractors

At the time of bid, bidders shall submit all DBE participation that they anticipate to use during the life of the contract. Only those identified to meet the DBE goal will be considered committed, even though the listing shall include both committed DBE subcontractors and additional DBE subcontractors. Additional DBE subcontractor participation submitted at the time of bid will be used toward the Department's overall race-neutral goal. Only those firms with current DBE

certification at the time of bid opening will be acceptable for listing in the bidder's submittal of DBE participation. The Contractor shall indicate the following required information:

(A) Electronic Bids

Bidders shall submit a listing of DBE participation in the appropriate section of the electronic submittal file.

- (1) Submit the names and addresses of DBE firms identified to participate in the contract. If the bidder uses the updated listing of DBE firms shown in the electronic submittal file, the bidder may use the dropdown menu to access the name and address of the DBE firm.
- (2) Submit the contract line numbers of work to be performed by each DBE firm. When no figures or firms are entered, the bidder will be considered to have no DBE participation.
- (3) The bidder shall be responsible for ensuring that the DBE is certified at the time of bid by checking the Directory of Transportation Firms. If the firm is not certified at the time of the bid-letting, that DBE's participation will not count towards achieving the DBE goal.

(B) Paper Bids

- (1) *If the DBE goal is more than zero,*
 - (a) Bidders, at the time the bid proposal is submitted, shall submit a listing of DBE participation, including the names and addresses on *Listing of DBE Subcontractors* contained elsewhere in the contract documents in order for the bid to be considered responsive. Bidders shall indicate the total dollar value of the DBE participation for the contract.
 - (b) If bidders have no DBE participation, they shall indicate this on the *Listing of DBE Subcontractors* by entering the word "None" or the number "0." This form shall be completed in its entirety. **Blank forms will not be deemed to represent zero participation.** Bids submitted that do not have DBE participation indicated on the appropriate form will not be read publicly during the opening of bids. The Department will not consider these bids for award and the proposal will be rejected.
 - (c) The bidder shall be responsible for ensuring that the DBE is certified at the time of bid by checking the Directory of Transportation Firms. If the firm is not certified at the time of the bid-letting, that DBE's participation will not count towards achieving the corresponding goal.
- (2) *If the DBE goal is zero,* entries on the *Listing of DBE Subcontractors* are not required for the zero goal, however any DBE participation that is achieved during the project shall be reported in accordance with requirements contained elsewhere in the special provision.

DBE Prime Contractor

When a certified DBE firm bids on a contract that contains a DBE goal, the DBE firm is responsible for meeting the goal or making good faith efforts to meet the goal, just like any other bidder. In most cases, a DBE bidder on a contract will meet the DBE goal by virtue of the work it performs on the contract with its own forces. However, all the work that is performed by the DBE bidder and any other DBE subcontractors will count toward the DBE goal. The DBE bidder shall list itself along with any DBE subcontractors, if any, in order to receive credit toward the DBE goal.

For example, if the DBE goal is 45% and the DBE bidder will only perform 40% of the contract work, the prime will list itself at 40%, and the additional 5% shall be obtained through additional DBE participation with DBE subcontractors or documented through a good faith effort.

DBE prime contractors shall also follow Sections A and B listed under *Listing of DBE Subcontractor* just as a non-DBE bidder would.

Written Documentation – Letter of Intent

The bidder shall submit written documentation for each DBE that will be used to meet the DBE goal of the contract, indicating the bidder's commitment to use the DBE in the contract. This documentation shall be submitted on the Department's form titled *Letter of Intent*.

The documentation shall be received in the office of the State Contractor Utilization Engineer or at DBE@ncdot.gov no later than 10:00 a.m. of the sixth calendar day following opening of bids, unless the sixth day falls on an official state holiday. In that situation, it is due in the office of the State Contractor Utilization Engineer no later than 10:00 a.m. on the next official state business day.

If the bidder fails to submit the Letter of Intent from each committed DBE to be used toward the DBE goal, or if the form is incomplete (i.e. both signatures are not present), the DBE participation will not count toward meeting the DBE goal. If the lack of this participation drops the commitment below the DBE goal, the Contractor shall submit evidence of good faith efforts, completed in its entirety, to the State Contractor Utilization Engineer or DBE@ncdot.gov no later than 10:00 a.m. on the eighth calendar day following opening of bids, unless the eighth day falls on an official state holiday. In that situation, it is due in the office of the State Contractor Utilization Engineer no later than 10:00 a.m. on the next official state business day.

Submission of Good Faith Effort

If the bidder fails to meet or exceed the DBE goal, the apparent lowest responsive bidder shall submit to the Department documentation of adequate good faith efforts made to reach the DBE goal.

A hard copy and an electronic copy of this information shall be received in the office of the State Contractor Utilization Engineer or at DBE@ncdot.gov no later than 10:00 a.m. on the sixth calendar day following opening of bids unless the sixth day falls on an official state holiday. In that situation, it is due in the office of the State Contractor Utilization Engineer no later than 10:00 a.m.

on the next official state business day. If the contractor cannot send the information electronically, then one complete set and 5 copies of this information shall be received under the same time constraints above.

Note: Where the information submitted includes repetitious solicitation letters, it will be acceptable to submit a representative letter along with a distribution list of the firms that were solicited. Documentation of DBE quotations shall be a part of the good faith effort submittal. This documentation may include written subcontractor quotations, telephone log notations of verbal quotations, or other types of quotation documentation.

Consideration of Good Faith Effort for Projects with DBE Goals More Than Zero

Adequate good faith efforts mean that the bidder took all necessary and reasonable steps to achieve the goal which, by their scope, intensity, and appropriateness, could reasonably be expected to obtain sufficient DBE participation. Adequate good faith efforts also mean that the bidder actively and aggressively sought DBE participation. Mere *pro forma* efforts are not considered good faith efforts.

The Department will consider the quality, quantity, and intensity of the different kinds of efforts a bidder has made. Listed below are examples of the types of actions a bidder will take in making a good faith effort to meet the goal and are not intended to be exclusive or exhaustive, nor is it intended to be a mandatory checklist.

- (A) Soliciting through all reasonable and available means (e.g. attendance at pre-bid meetings, advertising, written notices, use of verifiable electronic means through the use of the NCDOT Directory of Transportation Firms) the interest of all certified DBEs who have the capability to perform the work of the contract. The bidder must solicit this interest within at least 10 days prior to bid opening to allow the DBEs to respond to the solicitation. Solicitation shall provide the opportunity to DBEs within the Division and surrounding Divisions where the project is located. The bidder must determine with certainty if the DBEs are interested by taking appropriate steps to follow up initial solicitations.
- (B) Selecting portions of the work to be performed by DBEs in order to increase the likelihood that the DBE goals will be achieved.
 - (1) Where appropriate, break out contract work items into economically feasible units to facilitate DBE participation, even when the prime contractor might otherwise prefer to perform these work items with its own forces.
 - (2) Negotiate with subcontractors to assume part of the responsibility to meet the contract DBE goal when the work to be sublet includes potential for DBE participation (2nd and 3rd tier subcontractors).
- (C) Providing interested DBEs with adequate information about the plans, specifications, and requirements of the contract in a timely manner to assist them in responding to a solicitation.
- (D) (1) Negotiating in good faith with interested DBEs. It is the bidder's responsibility to

make a portion of the work available to DBE subcontractors and suppliers and to select those portions of the work or material needs consistent with the available DBE subcontractors and suppliers, to facilitate DBE participation. Evidence of such negotiation includes the names, addresses, and telephone numbers of DBEs that were considered; a description of the information provided regarding the plans and specifications for the work selected for subcontracting; and evidence as to why additional agreements could not be reached for DBEs to perform the work.

- (2) A bidder using good business judgment would consider a number of factors in negotiating with subcontractors, including DBE subcontractors, and would take a firm's price and capabilities as well as contract goals into consideration. However, the fact that there may be some additional costs involved in finding and using DBEs is not in itself sufficient reason for a bidder's failure to meet the contract DBE goal, as long as such costs are reasonable. Also, the ability or desire of a prime contractor to perform the work of a contract with its own organization does not relieve the bidder of the responsibility to make good faith efforts. Bidding contractors are not, however, required to accept higher quotes from DBEs if the price difference is excessive or unreasonable.
- (E) Not rejecting DBEs as being unqualified without sound reasons based on a thorough investigation of their capabilities. The bidder's standing within its industry, membership in specific groups, organizations, or associates and political or social affiliations (for example, union vs. non-union employee status) are not legitimate causes for the rejection or non-solicitation of bids in the bidder's efforts to meet the project goal.
- (F) Making efforts to assist interested DBEs in obtaining bonding, lines of credit, or insurance as required by the recipient or bidder.
- (G) Making efforts to assist interested DBEs in obtaining necessary equipment, supplies, materials, or related assistance or services.
- (H) Effectively using the services of available minority/women community organizations; minority/women contractors' groups; Federal, State, and local minority/women business assistance offices; and other organizations as allowed on a case-by-case basis to provide assistance in the recruitment and placement of DBEs. Contact within 7 days from the bid opening the Business Opportunity and Work Force Development Unit at BOWD@ncdot.gov to give notification of the bidder's inability to get DBE quotes.
- (I) Any other evidence that the bidder submits which shows that the bidder has made reasonable good faith efforts to meet the DBE goal.

In addition, the Department may take into account the following:

- (1) Whether the bidder's documentation reflects a clear and realistic plan for achieving the DBE goal.
- (2) The bidders' past performance in meeting the DBE goals.

- (3) The performance of other bidders in meeting the DBE goal. For example, when the apparent successful bidder fails to meet the DBE goal, but others meet it, you may reasonably raise the question of whether, with additional reasonable efforts the apparent successful bidder could have met the goal. If the apparent successful bidder fails to meet the DBE goal, but meets or exceeds the average DBE participation obtained by other bidders, the Department may view this, in conjunction with other factors, as evidence of the apparent successful bidder having made a good faith effort.

If the Department does not award the contract to the apparent lowest responsive bidder, the Department reserves the right to award the contract to the next lowest responsive bidder that can satisfy to the Department that the DBE goal can be met or that an adequate good faith effort has been made to meet the DBE goal.

Non-Good Faith Appeal

The State Prequalification Engineer will notify the contractor verbally and in writing of non-good faith. A contractor may appeal a determination of non-good faith made by the Goal Compliance Committee. If a contractor wishes to appeal the determination made by the Committee, they shall provide written notification to the State Prequalification Engineer or at DBE@ncdot.gov. The appeal shall be made within 2 business days of notification of the determination of non-good faith.

Counting DBE Participation Toward Meeting DBE Goal

(A) Participation

The total dollar value of the participation by a committed DBE will be counted toward the contract goal requirement. The total dollar value of participation by a committed DBE will be based upon the value of work actually performed by the DBE and the actual payments to DBE firms by the Contractor.

(B) Joint Checks

Prior notification of joint check use shall be required when counting DBE participation for services or purchases that involves the use of a joint check. Notification shall be through submission of Form JC-1 (*Joint Check Notification Form*) and the use of joint checks shall be in accordance with the Department's Joint Check Procedures.

(C) Subcontracts (Non-Trucking)

A DBE may enter into subcontracts. Work that a DBE subcontracts to another DBE firm may be counted toward the contract goal requirement. Work that a DBE subcontracts to a non-DBE firm does not count toward the contract goal requirement. If a DBE contractor or subcontractor subcontracts a significantly greater portion of the work of the contract than would be expected on the basis of standard industry practices, it shall be presumed that the DBE is not performing a commercially useful function. The DBE may present evidence to rebut this presumption to the Department. The Department's decision on the rebuttal of this presumption is subject to review by the Federal Highway Administration but is not administratively appealable to USDOT.

(D) Joint Venture

When a DBE performs as a participant in a joint venture, the Contractor may count toward its contract goal requirement a portion of the total value of participation with the DBE in the joint venture, that portion of the total dollar value being a distinct clearly defined portion of work that the DBE performs with its forces.

(E) Suppliers

A contractor may count toward its DBE requirement 60 percent of its expenditures for materials and supplies required to complete the contract and obtained from a DBE regular dealer and 100 percent of such expenditures from a DBE manufacturer.

(F) Manufacturers and Regular Dealers

A contractor may count toward its DBE requirement the following expenditures to DBE firms that are not manufacturers or regular dealers:

- (1) The fees or commissions charged by a DBE firm for providing a *bona fide* service, such as professional, technical, consultant, or managerial services, or for providing bonds or insurance specifically required for the performance of a DOT-assisted contract, provided the fees or commissions are determined to be reasonable and not excessive as compared with fees and commissions customarily allowed for similar services.
- (2) With respect to materials or supplies purchased from a DBE, which is neither a manufacturer nor a regular dealer, count the entire amount of fees or commissions charged for assistance in the procurement of the materials and supplies, or fees or transportation charges for the delivery of materials or supplies required on a job site (but not the cost of the materials and supplies themselves), provided the fees are determined to be reasonable and not excessive as compared with fees customarily allowed for similar services.

Commercially Useful Function

(A) DBE Utilization

The Contractor may count toward its contract goal requirement only expenditures to DBEs that perform a commercially useful function in the work of a contract. A DBE performs a commercially useful function when it is responsible for execution of the work of the contract and is carrying out its responsibilities by actually performing, managing, and supervising the work involved. To perform a commercially useful function, the DBE shall also be responsible with respect to materials and supplies used on the contract, for negotiating price, determining quality and quantity, ordering the material and installing (where applicable) and paying for the material itself. To determine whether a DBE is performing a commercially useful function, the Department will evaluate the amount of work subcontracted, industry practices, whether the amount the firm is to be paid under the

contract is commensurate with the work it is actually performing and the DBE credit claimed for its performance of the work, and any other relevant factors.

(B) DBE Utilization in Trucking

The following factors will be used to determine if a DBE trucking firm is performing a commercially useful function:

- (1) The DBE shall be responsible for the management and supervision of the entire trucking operation for which it is responsible on a particular contract, and there shall not be a contrived arrangement for the purpose of meeting DBE goals.
- (2) The DBE shall itself own and operate at least one fully licensed, insured, and operational truck used on the contract.
- (3) The DBE receives credit for the total value of the transportation services it provides on the contract using trucks it owns, insures, and operates using drivers it employs.
- (4) The DBE may subcontract the work to another DBE firm, including an owner-operator who is certified as a DBE. The DBE who subcontracts work to another DBE receives credit for the total value of the transportation services the subcontracted DBE provides on the contract.
- (5) The DBE may also subcontract the work to a non-DBE firm, including from an owner-operator. The DBE who subcontracts the work to a non-DBE is entitled to credit for the total value of transportation services provided by the non-DBE subcontractor not to exceed the value of transportation services provided by DBE-owned trucks on the contract. Additional participation by non-DBE subcontractors receives credit only for the fee or commission it receives as a result of the subcontract arrangement. The value of services performed under subcontract agreements between the DBE and the Contractor will not count towards the DBE contract requirement.
- (6) A DBE may lease truck(s) from an established equipment leasing business open to the general public. The lease must indicate that the DBE has exclusive use of and control over the truck. This requirement does not preclude the leased truck from working for others during the term of the lease with the consent of the DBE, so long as the lease gives the DBE absolute priority for use of the leased truck. This type of lease may count toward the DBE's credit as long as the driver is under the DBE's payroll.
- (7) Subcontracted/leased trucks shall display clearly on the dashboard the name of the DBE that they are subcontracted/leased to and their own company name if it is not identified on the truck itself. Magnetic door signs are not permitted.

DBE Replacement

When a Contractor has relied on a commitment to a DBE subcontractor (or an approved substitute DBE subcontractor) to meet all or part of a contract goal requirement, the contractor shall not

terminate the DBE subcontractor for convenience. This includes, but is not limited to, instances in which the Contractor seeks to perform the work of the terminated subcontractor with another DBE subcontractor, a non-DBE subcontractor, or with the Contractor's own forces or those of an affiliate.

The Contractor must give notice in writing both by certified mail and email to the DBE subcontractor, with a copy to the Engineer of its intent to request to terminate and/or substitute, and the reason for the request. The Contractor must give the DBE subcontractor five (5) business days to respond to the Contractor's Notice of Intent to Request Termination and/or Substitution. If the DBE subcontractor objects to the intended termination/substitution, the DBE, within five (5) business days must advise the Contractor and the Department of the reasons why the action should not be approved. The five-day notice period shall begin on the next business day after written notice is provided to the DBE subcontractor.

A committed DBE subcontractor may only be terminated after receiving the Department's written approval based upon a finding of good cause for the proposed termination and/or substitution. For purposes of this section, good cause shall include the following circumstances:

- (a) The listed DBE subcontractor fails or refuses to execute a written contract;
- (b) The listed DBE subcontractor fails or refuses to perform the work of its subcontract in a way consistent with normal industry standards. Provided, however, that good cause does not exist if the failure or refusal of the DBE subcontractor to perform its work on the subcontract results from the bad faith or discriminatory action of the prime contractor;
- (c) The listed DBE subcontractor fails or refuses to meet the prime contractor's reasonable, nondiscriminatory bond requirements;
- (d) The listed DBE subcontractor becomes bankrupt, insolvent, or exhibits credit unworthiness;
- (e) The listed DBE subcontractor is ineligible to work on public works projects because of suspension and debarment proceedings pursuant to 2 CFR Parts 180, 215 and 1,200 or applicable state law;
- (f) The listed DBE subcontractor is not a responsible contractor;
- (g) The listed DBE voluntarily withdraws from the project and provides written notice of withdrawal;
- (h) The listed DBE is ineligible to receive DBE credit for the type of work required;
- (i) A DBE owner dies or becomes disabled with the result that the listed DBE contractor is unable to complete its work on the contract;
- (j) Other documented good cause that compels the termination of the DBE subcontractor. Provided, that good cause does not exist if the prime contractor seeks to terminate a DBE it relied upon to obtain the contract so that the prime contractor can self-perform the work for which the DBE contractor was engaged or so that the prime contractor can substitute another DBE or non-DBE contractor after contract award.

The Contractor shall comply with the following for replacement of a committed DBE:

(A) Performance Related Replacement

When a committed DBE is terminated for good cause as stated above, an additional DBE that was submitted at the time of bid may be used to fulfill the DBE commitment. A good faith effort will only be required for removing a committed DBE if there were no additional DBEs submitted at the time of bid to cover the same amount of work as the DBE that was terminated.

If a replacement DBE is not found that can perform at least the same amount of work as the terminated DBE, the Contractor shall submit a good faith effort documenting the steps taken. Such documentation shall include, but not be limited to, the following:

- (1) Copies of written notification to DBEs that their interest is solicited in contracting the work defaulted by the previous DBE or in subcontracting other items of work in the contract.
 - (2) Efforts to negotiate with DBEs for specific subbids including, at a minimum:
 - (a) The names, addresses, and telephone numbers of DBEs who were contacted.
 - (b) A description of the information provided to DBEs regarding the plans and specifications for portions of the work to be performed.
 - (3) A list of reasons why DBE quotes were not accepted.
 - (4) Efforts made to assist the DBEs contacted, if needed, in obtaining bonding or insurance required by the Contractor.
- (B) Decertification Replacement
- (1) When a committed DBE is decertified by the Department after the SAF (*Subcontract Approval Form*) has been received by the Department, the Department will not require the Contractor to solicit replacement DBE participation equal to the remaining work to be performed by the decertified firm. The participation equal to the remaining work performed by the decertified firm will count toward the contract goal requirement.
 - (2) When a committed DBE is decertified prior to the Department receiving the SAF (*Subcontract Approval Form*) for the named DBE firm, the Contractor shall take all necessary and reasonable steps to replace the DBE subcontractor with another DBE subcontractor to perform at least the same amount of work to meet the DBE goal requirement. If a DBE firm is not found to do the same amount of work, a good faith effort must be submitted to NCDOT (see A herein for required documentation).
 - (3) Exception: If the DBE's ineligibility is caused solely by its having exceeded the size standard during the performance of the contract, the Department will not require the Contractor to solicit replacement DBE participation equal to the remaining work to be performed by the decertified firm. The participation equal to the remaining work performed by the decertified firm will count toward the contract goal requirement and overall goal.

All requests for replacement of a committed DBE firm shall be submitted to the Engineer for approval on Form RF-1 (*DBE Replacement Request*). If the Contractor fails to follow this procedure, the Contractor may be disqualified from further bidding for a period of up to 6 months.

Changes in the Work

When the Engineer makes changes that result in the reduction or elimination of work to be performed by a committed DBE, the Contractor will not be required to seek additional participation. When the Engineer makes changes that result in additional work to be performed by a DBE based upon the Contractor's commitment, the DBE shall participate in additional work to the same extent as the DBE participated in the original contract work.

When the Engineer makes changes that result in extra work, which has more than a minimal impact on the contract amount, the Contractor shall seek additional participation by DBEs unless otherwise approved by the Engineer.

When the Engineer makes changes that result in an alteration of plans or details of construction, and a portion or all of the work had been expected to be performed by a committed DBE, the Contractor shall seek participation by DBEs unless otherwise approved by the Engineer.

When the Contractor requests changes in the work that result in the reduction or elimination of work that the Contractor committed to be performed by a DBE, the Contractor shall seek additional participation by DBEs equal to the reduced DBE participation caused by the changes.

Reports and Documentation

A SAF (*Subcontract Approval Form*) shall be submitted for all work which is to be performed by a DBE subcontractor. The Department reserves the right to require copies of actual subcontract agreements involving DBE subcontractors.

When using transportation services to meet the contract commitment, the Contractor shall submit a proposed trucking plan in addition to the SAF. The plan shall be submitted prior to beginning construction on the project. The plan shall include the names of all trucking firms proposed for use, their certification type(s), the number of trucks owned by the firm, as well as the individual truck identification numbers, and the line item(s) being performed.

Within 30 calendar days of entering into an agreement with a DBE for materials, supplies or services, not otherwise documented by the SAF as specified above, the Contractor shall furnish the Engineer a copy of the agreement. The documentation shall also indicate the percentage (60% or 100%) of expenditures claimed for DBE credit.

Reporting Disadvantaged Business Enterprise Participation

The Contractor shall provide the Engineer with an accounting of payments made to all DBE firms, including material suppliers and contractors at all levels (prime, subcontractor, or second tier subcontractor). This accounting shall be furnished to the Engineer for any given month by the end of the following month. Failure to submit this information accordingly may result in the following action:

- (A) Withholding of money due in the next partial pay estimate; or
- (B) Removal of an approved contractor from the prequalified bidders' list or the removal of other entities from the approved subcontractors list.

While each contractor (prime, subcontractor, 2nd tier subcontractor) is responsible for accurate accounting of payments to DBEs, it shall be the prime contractor's responsibility to report all monthly and final payment information in the correct reporting manner.

Failure on the part of the Contractor to submit the required information in the time frame specified may result in the disqualification of that contractor and any affiliate companies from further bidding until the required information is submitted.

Failure on the part of any subcontractor to submit the required information in the time frame specified may result in the disqualification of that contractor and any affiliate companies from being approved for work on future DOT projects until the required information is submitted.

Contractors reporting transportation services provided by non-DBE lessees shall evaluate the value of services provided during the month of the reporting period only.

At any time, the Engineer can request written verification of subcontractor payments.

The Contractor shall report the accounting of payments through the Department's DBE Payment Tracking System.

Failure to Meet Contract Requirements

Failure to meet contract requirements in accordance with Subarticle 102-15(J) of the *2018 Standard Specifications* may be cause to disqualify the Contractor.

CERTIFICATION FOR FEDERAL-AID CONTRACTS:

(3-21-90)

SP1 G85

The prospective participant certifies, by signing and submitting this bid or proposal, to the best of his or her knowledge and belief, that:

- (A) No Federal appropriated funds have been paid or will be paid, by or on behalf of the undersigned, to any person for influencing or attempting to influence an officer or employee of any Federal agency, a Member of Congress, an officer or employee of Congress, or an employee of a Member of Congress in connection with the awarding of any Federal contract, the making of any Federal grant, the making of any Federal loan, the entering into of any cooperative agreement, and the extension, continuation, renewal, amendment, or modification of any Federal contract, grant, loan, or cooperative agreement.
- (B) If any funds other than Federal appropriated funds have been paid or will be paid to any person for influencing or attempting to influence an officer or employee of any Federal agency, a Member of Congress, an officer or employee of Congress, or an employee of a Member of Congress in connection with this Federal contract, grant, loan, or cooperative agreement, the undersigned shall complete and submit Standard Form-LLL, *Disclosure Form to Report Lobbying*, in accordance with its instructions.

This certification is a material representation of fact upon which reliance was placed when this transaction was made or entered into. Submission of this certification is a prerequisite for making or entering into this transaction imposed by *Section 1352, Title 31, U.S. Code*. Any person who

fails to file the required certification shall be subject to a civil penalty of not less than \$10,000 and not more than \$100,000 for each such failure.

The prospective participant also agrees by submitting his or her bid or proposal that he or she shall require that the language of this certification be included in all lower tier subcontracts, which exceed \$100,000 and that all such subrecipients shall certify and disclose accordingly.

RESTRICTIONS ON ITS EQUIPMENT AND SERVICES:

(11-17-20)

SP01 G090

All telecommunications, video or other ITS equipment or services installed or utilized on this project must be in conformance with UNIFORM ADMINISTRATIVE REQUIREMENTS, COST PRINCIPLES, AND AUDIT REQUIREMENTS FOR FEDERAL AWARDS 2 CFR, § 200.216 **Prohibition on certain telecommunications and video surveillance services or equipment.**

USE OF UNMANNED AIRCRAFT SYSTEM (UAS):

(8-20-19)

SP1 G092

The Contractor shall adhere to all Federal, State and Local regulations and guidelines for the use of Unmanned Aircraft Systems (UAS). This includes but is not limited to US 14 CFR Part 107 *Small UAS Rule*, NC GS 15A-300.2 *Regulation of launch and recovery sites*, NC GS 63-95 *Training required for the operation of unmanned aircraft systems*, NC GS 63-96 *Permit required for commercial operation of unmanned aircraft system*, and NCDOT UAS Policy. The required operator certifications include possessing a current Federal Aviation Administration (FAA) Remote Pilot Certificate, a NC UAS Operator Permit as well as operating a UAS registered with the FAA.

Prior to beginning operations, the Contractor shall complete the NCDOT UAS – Flight Operation Approval Form and submit it to the Engineer for approval. All UAS operations shall be approved by the Engineer prior to beginning the operations.

All contractors or subcontractors operating UAS shall have UAS specific general liability insurance to cover all operations under this contract.

The use of UAS is at the Contractor's discretion. No measurement or payment will be made for the use of UAS. In the event that the Department directs the Contractor to utilize UAS, payment will be in accordance with Article 104-7 Extra Work.

EQUIPMENT IDLING GUIDELINES:

(1-19-21)

107

SP1 G096

Exercise reduced fuel consumption and reduced equipment emissions during the construction of all work associated with this contract. Employees engaged in the construction of this project should turn off vehicles when stopped for more than thirty (30) minutes and off-highway equipment should idle no longer than fifteen (15) consecutive minutes.

These guidelines for turning off vehicles and equipment when idling do not apply to:

1. Idling when queuing.
2. Idling to verify the vehicle is in safe operating condition.

3. Idling for testing, servicing, repairing or diagnostic purposes.
4. Idling necessary to accomplish work for which the vehicle was designed (such as operating a crane, mixing concrete, etc.).
5. Idling required to bring the machine system to operating temperature.
6. Emergency vehicles, utility company, construction, and maintenance vehicles where the engines must run to perform needed work.
7. Idling to ensure safe operation of the vehicle.
8. Idling when the propulsion engine is providing auxiliary power for other than heating or air conditioning. (such as hydraulic systems for pavers)
9. When specific traffic, safety, or emergency situations arise.
10. If the ambient temperature is less than 32 degrees Fahrenheit. Limited idling to provide for the safety of vehicle occupants (e.g. to run the heater).
11. If the ambient temperature is greater than 90 degrees Fahrenheit. Limited idling to provide for the safety of vehicle occupants of off-highway equipment (e.g. to run the air conditioning) no more than 30 minutes.
12. Diesel powered vehicles may idle for up to 30 minutes to minimize restart problems.

Any vehicle, truck, or equipment in which the primary source of fuel is natural gas or electricity is exempt from the idling limitations set forth in this special provision.

U.S. DEPARTMENT OF TRANSPORTATION HOTLINE:

(11-22-94)

108-5

SP1 G100

To report bid rigging activities call: **1-800-424-9071**

The U.S. Department of Transportation (DOT) operates the above toll-free hotline Monday through Friday, 8:00 a.m. to 5:00 p.m. eastern time. Anyone with knowledge of possible bid rigging, bidder collusion, or other fraudulent activities should use the hotline to report such activities.

The hotline is part of the DOT's continuing effort to identify and investigate highway construction contract fraud and abuse is operated under the direction of the DOT Inspector General. All information will be treated confidentially and caller anonymity will be respected.

MAINTENANCE OF THE PROJECT:

(11-20-07) (Rev. 1-17-12)

104-10

SP1 G125

Revise the *2018 Standard Specifications* as follows:

Page 1-39, Article 104-10 Maintenance of the Project, line 25, add the following after the first sentence of the first paragraph:

All guardrail/guiderail within the project limits shall be included in this maintenance.

Page 1-39, Article 104-10 Maintenance of the Project, line 30, add the following as the last sentence of the first paragraph:

The Contractor shall perform weekly inspections of guardrail and guiderail and shall report damages to the Engineer on the same day of the weekly inspection. *Where damaged guardrail or guiderail is repaired or replaced as a result of maintaining the project in accordance with this*

article, such repair or replacement shall be performed within 7 consecutive calendar days of such inspection report.

Page 1-39, Article 104-10 Maintenance of the Project, lines 42-44, replace the last sentence of the last paragraph with the following:

The Contractor will not be directly compensated for any maintenance operations necessary, except for maintenance of guardrail/guiderail, as this work will be considered incidental to the work covered by the various contract items. The provisions of Article 104-7, Extra Work, and Article 104-8, Compensation and Record Keeping will apply to authorized maintenance of guardrail/guiderail. Performance of weekly inspections of guardrail/guiderail, and the damage reports required as described above, will be considered to be an incidental part of the work being paid for by the various contract items.

COOPERATION BETWEEN CONTRACTORS:

(7-1-95)

105-7

SP1 G133

The Contractor's attention is directed to Article 105-7 of the *2018 Standard Specifications*.

HO-0002C (C204556 - US-74 Broadband Infrastructure Project from Asheville to Wilmington) is located throughout the project limits. HO-0002C is currently under construction and not anticipated to be complete prior to the letting of this project.

R-5751 (C204772) is located adjacent to HI-0016. R-5751 is currently under construction and not anticipated to be complete prior to the letting of this project.

R-5797 (C204571) is located adjacent to HI-0016. R-5797 is currently under construction and not anticipated to be complete prior to the letting of this project.

The Contractor on this project shall cooperate with the Contractor working within or adjacent to the limits of this project to the extent that the work can be carried out to the best advantage of all concerned.

ELECTRONIC BIDDING:

(2-19-19)

101, 102, 103

SP1 G140

Revise the *2018 Standard Specifications* as follows:

Page 1-4, Article 101-3, DEFINITIONS, BID (OR PROPOSAL) *Electronic Bid*, line 1, replace “Bid Express®” with “the approved electronic bidding provider”.

Page 1-15, Subarticle 102-8(B), *Electronic Bids*, lines 39-40, replace “to Bid Express®” with “via the approved electronic bidding provider”.

Page 1-15, Subarticle 102-8(B)(1), *Electronic Bids*, line 41, delete “from Bid Express®”

Page 1-17, Subarticle 102-9(C)(2), *Electronic Bids*, line 21, replace “Bid Express® miscellaneous folder within the .ebs” with “electronic submittal”.

Page 1-29, Subarticle 103-4(C)(2), Electronic Bids, line 32, replace “.ebs miscellaneous data file of Expedite” with “electronic submittal file”

AWARD LIMITS:

(4-19-22)

103

SP1 G141

Revise the *2018 Standard Specifications* as follows:

Page 1-29, Subarticle 103-4(C), Award Limits, line 4-8, delete and replace the first sentence in the first paragraph with the following:

A bidder who desires to bid on more than one project on which bids are to be opened in the same letting and who desires to avoid receiving an award of more projects than he is equipped to handle, may bid on any number of projects but may limit the total amount of work awarded to him on selected projects by completing the form Award Limits on Multiple Projects for each project subject to the award limit.

TWELVE MONTH GUARANTEE:

(7-15-03)

108

SP1 G145

- (A) The Contractor shall guarantee materials and workmanship against latent and patent defects arising from faulty materials, faulty workmanship or negligence for a period of twelve months following the date of final acceptance of the work for maintenance and shall replace such defective materials and workmanship without cost to the Department. The Contractor will not be responsible for damage due to faulty design, normal wear and tear, for negligence on the part of the Department, and/or for use in excess of the design.
- (B) Where items of equipment or material carry a manufacturer’s guarantee for any period in excess of twelve months, then the manufacturer’s guarantee shall apply for that particular piece of equipment or material. The Department’s first remedy shall be through the manufacturer although the Contractor is responsible for invoking the warranted repair work with the manufacturer. The Contractor’s responsibility shall be limited to the term of the manufacturer’s guarantee. NCDOT would be afforded the same warranty as provided by the Manufacturer.

This guarantee provision shall be invoked only for major components of work in which the Contractor would be wholly responsible for under the terms of the contract. Examples would include pavement structures, bridge components, and sign structures. This provision will not be used as a mechanism to force the Contractor to return to the project to make repairs or perform additional work that the Department would normally compensate the Contractor for. In addition, routine maintenance activities (i.e. mowing grass, debris removal, ruts in earth shoulders,) are not parts of this guarantee.

Appropriate provisions of the payment and/or performance bonds shall cover this guarantee for the project.

To ensure uniform application statewide the Division Engineer will forward details regarding the circumstances surrounding any proposed guarantee repairs to the Chief Engineer for review and approval prior to the work being performed.

EROSION AND SEDIMENT CONTROL/STORMWATER CERTIFICATION:

(1-16-07) (Rev 12-15-20)

105-16, 225-2, 16

SP1 G180

General

Schedule and conduct construction activities in a manner that will minimize soil erosion and the resulting sedimentation and turbidity of surface waters. Comply with the requirements herein regardless of whether or not a National Pollution discharge Elimination System (NPDES) permit for the work is required.

Establish a chain of responsibility for operations and subcontractors' operations to ensure that the *Erosion and Sediment Control/Stormwater Pollution Prevention Plan* is implemented and maintained over the life of the contract.

- (A) *Certified Supervisor* - Provide a certified Erosion and Sediment Control/Stormwater Supervisor to manage the Contractor and subcontractor operations, insure compliance with Federal, State and Local ordinances and regulations, and manage the Quality Control Program.
- (B) *Certified Foreman* - Provide a certified, trained foreman for each construction operation that increases the potential for soil erosion or the possible sedimentation and turbidity of surface waters.
- (C) *Certified Installer* - Provide a certified installer to install or direct the installation for erosion or sediment/stormwater control practices.
- (D) *Certified Designer* - Provide a certified designer for the design of the erosion and sediment control/stormwater component of reclamation plans and, if applicable, for the design of the project erosion and sediment control/stormwater plan.

Roles and Responsibilities

- (A) *Certified Erosion and Sediment Control/Stormwater Supervisor* - The Certified Supervisor shall be Level II and responsible for ensuring the erosion and sediment control/stormwater plan is adequately implemented and maintained on the project and for conducting the quality control program. The Certified Supervisor shall be on the project within 24 hours notice from initial exposure of an erodible surface to the project's final acceptance. Perform the following duties:
 - (1) *Manage Operations* - Coordinate and schedule the work of subcontractors so that erosion and sediment control/stormwater measures are fully executed for each operation and in a timely manner over the duration of the contract.
 - (a) Oversee the work of subcontractors so that appropriate erosion and sediment control/stormwater preventive measures are conformed to at each stage of the work.
 - (b) Prepare the required National Pollutant Discharge Elimination System (NPDES) Inspection Record and submit to the Engineer.
 - (c) Attend all weekly or monthly construction meetings to discuss the findings of the NPDES inspection and other related issues.

- (d) Implement the erosion and sediment control/stormwater site plans requested.
 - (e) Provide any needed erosion and sediment control/stormwater practices for the Contractor's temporary work not shown on the plans, such as, but not limited to work platforms, temporary construction, pumping operations, plant and storage yards, and cofferdams.
 - (f) Acquire applicable permits and comply with requirements for borrow pits, dewatering, and any temporary work conducted by the Contractor in jurisdictional areas.
 - (g) Conduct all erosion and sediment control/stormwater work in a timely and workmanlike manner.
 - (h) Fully perform and install erosion and sediment control/stormwater work prior to any suspension of the work.
 - (i) Coordinate with Department, Federal, State and Local Regulatory agencies on resolution of erosion and sediment control/stormwater issues due to the Contractor's operations.
 - (j) Ensure that proper cleanup occurs from vehicle tracking on paved surfaces or any location where sediment leaves the Right-of-Way.
 - (k) Have available a set of erosion and sediment control/stormwater plans that are initialed and include the installation date of Best Management Practices. These practices shall include temporary and permanent groundcover and be properly updated to reflect necessary plan and field changes for use and review by Department personnel as well as regulatory agencies.
- (2) Requirements set forth under the NPDES Permit - The Department's NPDES Stormwater permit (NCS000250) outlines certain objectives and management measures pertaining to construction activities. The permit references *NCG010000, General Permit to Discharge Stormwater* under the NPDES, and states that the Department shall incorporate the applicable requirements into its delegated Erosion and Sediment Control Program for construction activities disturbing one or more acres of land. The Department further incorporates these requirements on all contracted bridge and culvert work at jurisdictional waters, regardless of size. Some of the requirements are, but are not limited to:
- (a) Control project site waste to prevent contamination of surface or ground waters of the state, i.e. from equipment operation/maintenance, construction materials, concrete washout, chemicals, litter, fuels, lubricants, coolants, hydraulic fluids, any other petroleum products, and sanitary waste.
 - (b) Inspect erosion and sediment control/stormwater devices and stormwater discharge outfalls at least once every 7 calendar days and within 24 hours after a rainfall event equal to or greater than 1.0 inch that occurs within a 24 hour period. Additional monitoring may be required at the discretion of Division of Water Resources personnel if the receiving stream is 303(d) listed for turbidity and the project has had documented problems managing turbidity.
 - (c) Maintain an onsite rain gauge or use the Department's Multi-Sensor Precipitation Estimate website to maintain a daily record of rainfall amounts and dates.

- (d) Maintain erosion and sediment control/stormwater inspection records for review by Department and Regulatory personnel upon request.
 - (e) Implement approved reclamation plans on all borrow pits, waste sites and staging areas.
 - (f) Maintain a log of turbidity test results as outlined in the Department's Procedure for Monitoring Borrow Pit Discharge.
 - (g) Provide secondary containment for bulk storage of liquid materials.
 - (h) Provide training for employees concerning general erosion and sediment control/stormwater awareness, the Department's NPDES Stormwater Permit NCS000250 requirements, and the applicable requirements of the *General Permit, NCG010000*.
 - (i) Report violations of the NPDES permit to the Engineer immediately who will notify the Division of Water Quality Regional Office within 24 hours of becoming aware of the violation.
- (3) Quality Control Program - Maintain a quality control program to control erosion, prevent sedimentation and follow provisions/conditions of permits. The quality control program shall:
- (a) Follow permit requirements related to the Contractor and subcontractors' construction activities.
 - (b) Ensure that all operators and subcontractors on site have the proper erosion and sediment control/stormwater certification.
 - (c) Notify the Engineer when the required certified erosion and sediment control/stormwater personnel are not available on the job site when needed.
 - (d) Conduct the inspections required by the NPDES permit.
 - (e) Take corrective actions in the proper timeframe as required by the NPDES permit for problem areas identified during the NPDES inspections.
 - (f) Incorporate erosion control into the work in a timely manner and stabilize disturbed areas with mulch/seed or vegetative cover on a section-by-section basis.
 - (g) Use flocculants approved by state regulatory authorities where appropriate and where required for turbidity and sedimentation reduction.
 - (h) Ensure proper installation and maintenance of temporary erosion and sediment control devices.
 - (i) Remove temporary erosion or sediment control devices when they are no longer necessary as agreed upon by the Engineer.
 - (j) The Contractor's quality control and inspection procedures shall be subject to review by the Engineer. Maintain NPDES inspection records and make records available at all times for verification by the Engineer.
- (B) *Certified Foreman* - At least one Certified Foreman shall be onsite for each type of work listed herein during the respective construction activities to control erosion, prevent sedimentation and follow permit provisions:
- (1) Foreman in charge of grading activities
 - (2) Foreman in charge of bridge or culvert construction over jurisdictional areas
 - (3) Foreman in charge of utility activities

The Contractor may request to use the same person as the Level II Supervisor and Level II Foreman. This person shall be onsite whenever construction activities as described above are taking place. This request shall be approved by the Engineer prior to work beginning.

The Contractor may request to name a single Level II Foreman to oversee multiple construction activities on small bridge or culvert replacement projects. This request shall be approved by the Engineer prior to work beginning.

(C) *Certified Installers* - Provide at least one onsite, Level I Certified Installer for each of the following erosion and sediment control/stormwater crew:

- (1) Seeding and Mulching
- (2) Temporary Seeding
- (3) Temporary Mulching
- (4) Sodding
- (5) Silt fence or other perimeter erosion/sediment control device installations
- (6) Erosion control blanket installation
- (7) Hydraulic tackifier installation
- (8) Turbidity curtain installation
- (9) Rock ditch check/sediment dam installation
- (10) Ditch liner/matting installation
- (11) Inlet protection
- (12) Riprap placement
- (13) Stormwater BMP installations (such as but not limited to level spreaders, retention/detention devices)
- (14) Pipe installations within jurisdictional areas

If a Level I *Certified Installer* is not onsite, the Contractor may substitute a Level II Foreman for a Level I Installer, provided the Level II Foreman is not tasked to another crew requiring Level II Foreman oversight.

(D) *Certified Designer* - Include the certification number of the Level III Certified Designer on the erosion and sediment control/stormwater component of all reclamation plans and if applicable, the certification number of the Level III Certified Designer on the design of the project erosion and sediment control/stormwater plan.

Preconstruction Meeting

Furnish the names of the *Certified Erosion and Sediment Control/Stormwater Supervisor*, *Certified Foremen*, *Certified Installers* and *Certified Designer* and notify the Engineer of changes in certified personnel over the life of the contract within 2 days of change.

Ethical Responsibility

Any company performing work for the North Carolina Department of Transportation has the ethical responsibility to fully disclose any reprimand or dismissal of an employee resulting from improper testing or falsification of records.

Revocation or Suspension of Certification

Upon recommendation of the Chief Engineer to the certification entity, certification for *Supervisor*, *Certified Foremen*, *Certified Installers* and *Certified Designer* may be revoked or suspended with the issuance of an *Immediate Corrective Action (ICA)*, *Notice of Violation (NOV)*, or *Cease and Desist Order* for erosion and sediment control/stormwater related issues.

The Chief Engineer may recommend suspension or permanent revocation of certification due to the following:

- (A) Failure to adequately perform the duties as defined within this certification provision.
- (B) Issuance of an ICA, NOV, or Cease and Desist Order.
- (C) Failure to fully perform environmental commitments as detailed within the permit conditions and specifications.
- (D) Demonstration of erroneous documentation or reporting techniques.
- (E) Cheating or copying another candidate's work on an examination.
- (F) Intentional falsification of records.
- (G) Directing a subordinate under direct or indirect supervision to perform any of the above actions.
- (H) Dismissal from a company for any of the above reasons.
- (I) Suspension or revocation of one's certification by another entity.

Suspension or revocation of a certification will be sent by certified mail to the certificant and the Corporate Head of the company that employs the certificant.

A certificant has the right to appeal any adverse action which results in suspension or permanent revocation of certification by responding, in writing, to the Chief Engineer within 10 calendar days after receiving notice of the proposed adverse action.

Chief Engineer
1536 Mail Service Center
Raleigh, NC 27699-1536

Failure to appeal within 10 calendar days will result in the proposed adverse action becoming effective on the date specified on the certified notice. Failure to appeal within the time specified will result in a waiver of all future appeal rights regarding the adverse action taken. The certificant will not be allowed to perform duties associated with the certification during the appeal process.

The Chief Engineer will hear the appeal and make a decision within 7 days of hearing the appeal. Decision of the Chief Engineer will be final and will be made in writing to the certificant.

If a certification is temporarily suspended, the certificant shall pass any applicable written examination and any proficiency examination, at the conclusion of the specified suspension period, prior to having the certification reinstated.

Measurement and Payment

Certified Erosion and Sediment Control/Stormwater Supervisor, Certified Foremen, Certified Installers and Certified Designer will be incidental to the project for which no direct compensation will be made.

PROCEDURE FOR MONITORING BORROW PIT DISCHARGE:

(2-20-07) (Rev. 4-5-19)

105-16, 230, 801

SP1 G181

Water discharge from borrow pit sites shall not cause surface waters to exceed 50 NTUs (nephelometric turbidity unit) in streams not designated as trout waters and 10 NTUs in streams, lakes or reservoirs designated as trout waters. For lakes and reservoirs not designated as trout waters, the turbidity shall not exceed 25 NTUs. If the turbidity exceeds these levels due to natural background conditions, the existing turbidity level shall not be increased.

If during any operating day, the downstream water quality exceeds the standard, the Contractor shall do all of the following:

- (A) Either cease discharge or modify the discharge volume or turbidity levels to bring the downstream turbidity levels into compliance, or
- (B) Evaluate the upstream conditions to determine if the exceedance of the standard is due to natural background conditions. If the background turbidity measurements exceed the standard, operation of the pit and discharge can continue as long as the stream turbidity levels are not increased due to the discharge.
- (C) Measure and record the turbidity test results (time, date and sampler) at all defined sampling locations 30 minutes after startup and at a minimum, one additional sampling of all sampling locations during that 24-hour period in which the borrow pit is discharging.
- (D) Notify DWQ within 24 hours of any stream turbidity standard exceedances that are not brought into compliance.

During the Environmental Assessment required by Article 230-4 of the *2018 Standard Specifications*, the Contractor shall define the point at which the discharge enters into the State's surface waters and the appropriate sampling locations. Sampling locations shall include points upstream and downstream from the point at which the discharge enters these waters. Upstream sampling location shall be located so that it is not influenced by backwater conditions and represents natural background conditions. Downstream sampling location shall be located at the point where complete mixing of the discharge and receiving water has occurred.

The discharge shall be closely monitored when water from the dewatering activities is introduced into jurisdictional wetlands. Any time visible sedimentation (deposition of sediment) on the wetland surface is observed, the dewatering activity will be suspended until turbidity levels in the stilling basin can be reduced to a level where sediment deposition does not occur. Staining of wetland surfaces from suspended clay particles, occurring after evaporation or infiltration, does not constitute sedimentation. No activities shall occur in wetlands that adversely affect the functioning of a wetland. Visible sedimentation will be considered an indication of possible adverse impacts on wetland use.

The Engineer will perform independent turbidity tests on a random basis. These results will be maintained in a log within the project records. Records will include, at a minimum, turbidity test results, time, date and name of sampler. Should the Department's test results exceed those of the Contractor's test results, an immediate test shall be performed jointly with the results superseding the previous test results of both the Department and the Contractor.

The Contractor shall use the *NCDOT Turbidity Reduction Options for Borrow Pits Matrix*, available at <https://connect.ncdot.gov/resources/roadside/FieldOperationsDocuments/TurbidityReductionOptionSheet.pdf> to plan, design, construct, and maintain BMPs to address water quality standards. Tier I Methods include stilling basins which are standard compensatory BMPs. Other Tier I methods are noncompensatory and shall be used when needed to meet the stream turbidity standards. Tier II Methods are also noncompensatory and are options that may be needed for protection of rare or unique resources or where special environmental conditions exist at the site which have led to additional requirements being placed in the DWQ's 401 Certifications and approval letters, Isolated Wetland Permits, Riparian Buffer Authorization or a DOT Reclamation Plan's Environmental Assessment for the specific site. Should the Contractor exhaust all Tier I Methods on a site exclusive of rare or unique resources or special environmental conditions, Tier II Methods may be required by regulators on a case by case basis per supplemental agreement.

The Contractor may use cation exchange capacity (CEC) values from proposed site borings to plan and develop the bid for the project. CEC values exceeding 15 milliequivalents per 100 grams of soil may indicate a high potential for turbidity and should be avoided when dewatering into surface water is proposed.

No additional compensation for monitoring borrow pit discharge will be paid.

PROJECT SPECIAL PROVISIONS**ROADWAY****SHOULDER RECONSTRUCTION PER SHOULDER MILE:**

(1-18-00) (Rev. 1-17-23)

560, 1019

SPI R07R

Description

The work covered by this provision consists of clipping high shoulders and reconstructing the earth shoulder in accordance with Standard Drawing No. 560.01 and 560.02 of the *Roadway Standard Drawings* with the following exceptions: the width will be shown on typical sections, or to the existing shoulder point, whichever is nearer, as long as the desired typical is achieved. Seeding and mulching shall be performed upon completion of shoulder grading when earth borrow is used.

This work shall be performed immediately after the resurfacing operations are complete as directed by the Engineer.

Materials

The Contractor shall furnish all earth material necessary for the construction of the shoulders in accordance with Section 1019 of the *Standard Specifications*. All soil is subject to test and acceptance or rejection by the Engineer.

The Contractor is required to use Aggregate Shoulder Borrow (ASB) on all maps with shoulder reconstruction with the exception of areas considered residential lawns, where borrow excavation is needed. Borrow excavation shall be used in lieu of ASB if directed by the contract or Engineer.

ASB shall meet the following gradation:

<u>Sieve</u>	<u>Percent Passing</u>
1 1/2"	100
1/2"	55 - 95
#4	35 - 74

Construction Methods

Obtain material from within the project limits or approved source. Prior to adding ASB material, the existing shoulder shall be scarified to provide the proper bond and shall be compacted to the satisfaction of the Engineer.

Any excess material generated by the shoulder reconstruction shall be disposed of by the Contractor in an approved disposal site.

Measurement and Payment

Shoulder Reconstruction will be measured and paid as the actual number of miles of shoulders that have been reconstructed and accepted by the Engineer. Measurement will be made along the surface of each shoulder to the nearest 0.01 of a mile. Such price will include disposing of any

excess material in an approved disposal site, and for all labor, tools, equipment, and incidentals necessary to complete the work.

Aggregate Shoulder Borrow will be measured and paid at the contract unit price per ton that has been incorporated into the completed work that is accepted by the Engineer. The number of tons of material is determined by weighing the material in trucks in accordance with Article 106-7. No deductions will be made for any moisture contained in the aggregate at time of weighing.

Borrow Excavation will be measured and paid in accordance with Section 230 of the *Standard Specifications* for earth material furnished by the Contractor. The requirements of Article 104-5 of the *Standard Specifications* pertaining to revised contract prices for overrunning minor items will not apply to the item of *Borrow Excavation*.

Incidental Stone Base will be measured and paid as provided in Article 545-6 of the *Standard Specifications*. Where ASB is used, *Incidental Stone Base* will not be required.

Seeding and Mulching will be measured and paid as provided in Article 1660-8 of the *Standard Specifications*.

Where ASB is used, seeding and mulching will not be required.

Payment will be made under:

Pay Item

Shoulder Reconstruction

Aggregate Shoulder Borrow

Pay Unit

Shoulder Mile

Ton

SHOULDER RECONSTRUCTION PROCEDURE:

(7-1-95) (Rev. 10-15-13)

560

SP1 R10BR

Perform shoulder reconstruction immediately following paving operations and in no case allow paving operations to exceed shoulder operations by more than two weeks without written permission of the Engineer. Failure to meet this requirement shall be cause to cease paving operations until it can be met. Place final pavement marking after shoulder reconstruction.

Upon completion of shoulder reconstruction, remove construction signs and use on other projects or store at the county maintenance installation or as directed by the Engineer.

CULVERT PIPE:

(8-20-19)(Rev. 5-17-22)

305,310

SP3 R35

Revise the *2018 Standard Specifications* as follows:

Page 3-5, Article 305-1 DESCRIPTION, lines 12-14, replace with the following:

Where shown in the plans, the Contractor may use reinforced concrete pipe, aluminum alloy pipe, aluminized corrugated steel pipe, galvanized corrugated steel pipe, HDPE pipe, Polypropylene pipe or PVC pipe in accordance with the following requirements.

Page 3-5, Article 305-2 MATERIALS, add the following after line 16:

Item	Section
Polypropylene Pipe	1032-9
Galvanized Corrugated Steel Pipe	1032-3

Page 3-6, Article 310-2 MATERIALS, add the following after line 9:

Item	Section
Polypropylene Pipe	1032-9
Galvanized Corrugated Steel Pipe	1032-3

Page 3-6, Article 310-4 SIDE DRAIN PIPE, lines 24-25, replace the first sentence of the second paragraph with the following:

Where shown in the plans, side drain pipe may be Class II reinforced concrete pipe, aluminized corrugated steel pipe, galvanized corrugated steel pipe, corrugated aluminum alloy pipe, Polypropylene pipe, HDPE pipe or PVC pipe.

Page 3-7, Article 310-5 PIPE END SECTIONS, lines 2-4, replace the second sentence with the following:

Both corrugated steel and concrete pipe end sections will work on concrete pipe, corrugated steel pipe, Polypropylene pipe and HDPE smooth lined corrugated plastic pipe.

Page 3-7, Article 310-6 MEASUREMENT AND PAYMENT, add the following after line 14:

Pay Item	Pay Unit
__" Polypropylene Pipe	Linear Foot

Page 10-60, add Article 1032-9:

(A) General

Use polypropylene pipe from sources participating in the Department's Polypropylene Pipe QA/QC Program. A list of participating sources is available from the Materials and Tests Unit. The Department will remove a manufacturer of polypropylene pipe from this program if the monitoring efforts indicated that non-specification material is being provided or test procedures are not being followed.

Use polypropylene culvert pipe that meets AASHTO M 330 for Type S or Type D, or ASTM F2881 or ASTM F2764 Double or Triple wall; and has been evaluated by NTPEP.

(B) End Treatments, Pipe Tees and Elbows

End treatments, pipe tees and elbows shall meet AASHTO M 330, Section 7.7, or ASTM F2764, Section 6.6.

(C) Marking

Clearly mark each section of pipe, end section, tee and elbow and other accessories according to the Department's Polypropylene Pipe QC/QA Program:

- (1) AASHTO or ASTM Designation
- (2) The date of manufacture
- (3) Name or trademark of the manufacturer

When polypropylene pipe, end sections, tees and elbows have been inspected and accepted a sticker will be applied to the inside of the pipe. Do not use pipe sections, flared end sections, tees or elbows which do not have this seal of approval.

INCIDENTAL STONE BASE:

(7-1-95) (Rev.8-21-12)

545

SP5 R28R

Description

Place incidental stone base on driveways, mailboxes, etc. immediately after paving and do not have the paving operations exceed stone base placement by more than one week without written permission of the Engineer.

Materials and Construction

Provide and place incidental stone base in accordance with Section 545 of the *2018 Standard Specifications*.

Measurement and Payment

Incidental Stone Base will be measured and paid in accordance with Article 545-6 of the *2018 Standard Specifications*.

INCIDENTAL MILLING:

(11-15-22)(Rev. 1-17-23)

607

SP6 R02R

Revise the *2018 Standard Specifications* as follows:

Page 6-5, Article 607-3 CONSTRUCTION METHODS, add the following paragraph after line 45:

Variable depth milling is intended to improve the cross-sectional slope of the pavement.

Page 6-6, Article 607-3 CONSTRUCTION METHODS, line 9, delete and replace the first sentence in the sixth paragraph with the following:

The Engineer may require re-milling of any area exhibiting pavement laminations, scabbing or other defects.

Page 6-6, Article 607-4 TOLERANCE, lines 17-18, delete and replace the second sentence with the following:

The Engineer may vary the depth of milling by not more than one inch. In the event the directed depth of milling cut is altered by the Engineer more than one inch, either the Department or the Contractor may request an adjustment in unit price in accordance with Article 104-3. In administering Article 104-3, the Department will give no consideration to value given to RAP due to the deletion or reduction in quantity of milling. Article 104-3 will not apply to the item of *Incidental Milling*.

Page 6-6, Subarticle 607-5(A) Milled Asphalt Pavement, lines 21-23, delete and replace the first sentence with the following:

Milled Asphalt Pavement, ___" Depth will be measured and paid as the actual number of square yards of pavement surface milled in accordance with this specification.

Page 6-6, Subarticle 607-5(A) Milled Asphalt Pavement, lines 24-28, delete and replace the third and fourth sentence with the following:

The width will be the width required by the plans or directed by the Engineer, measured along the pavement surface. Areas to be paid under this item include mainline travel lanes, full width turn lanes greater than 500 feet in length, collector lanes, shoulders, and any additional equipment necessary to remove pavement in the area of manholes, water valves, curb, gutter and other obstructions.

Page 6-6, Subarticle 607-5(B) Milled Asphalt Pavement Depth Varies from Required Depth, lines 29-37, delete and replace the title and first paragraph with the following:

(B) Variable Depth Milled Asphalt Pavement

Milling Asphalt Pavement, ___" to ___" will be measured and paid as the actual number of square yards of pavement surface milled in accordance with this specification. In measuring this quantity, the length will be the actual length milled, measured along the pavement surface. The width will be the width required by the plans or directed by the Engineer, measured along the pavement surface. Areas to be paid under this item include mainline travel lanes, full width turn lanes greater than 500 feet in length, collector lanes, shoulders, and any additional equipment necessary to remove pavement in the area of manholes, water valves, curb, gutter and other obstructions.

Page 6-6, Subarticle 607-5(C) Incidental Milling, lines 45-49, delete and replace the first and second sentence with the following:

Incidental Milling will be measured and paid as the actual number of square yards of surface milled where the Contractor is required to mill butt joints, irregular areas, full width turn lanes 500 feet or less, intersections and re-mill areas that are not due to the Contractor's negligence. In measuring this quantity, the length will be the actual length milled, measured along the pavement surface. The width will be the width required by the plans or directed by the Engineer, measured along the pavement surface.

Page 6-7, Subarticle 607-5(D) Milling of Defects, lines 6-10, delete and replace the second sentence with the following:

If the Engineer directs re-milling of an area and is not due to the Contractor's negligence, the re-milled area will be measured as provided in Subarticle 607-5(C) and paid at the contract unit price per square yard for *Incidental Milling*.

PRICE ADJUSTMENT - ASPHALT BINDER FOR PLANT MIX:

(11-21-00)

620

SP6 R25

Price adjustments for asphalt binder for plant mix will be made in accordance with Section 620 of the *2018 Standard Specifications*.

The base price index for asphalt binder for plant mix is **\$ 595.00** per ton.

This base price index represents an average of F.O.B. selling prices of asphalt binder at supplier's terminals on **November 1, 2023**.

MILLING ASPHALT PAVEMENT:

(1-15-19)

607

SP6 R59

Revise the *2018 Standard Specifications* as follows:

Page 6-5, Article 607-2, EQUIPMENT, lines 14-16, delete the seventh sentence of this Article and replace with the following:

Use either a non-contacting laser or sonar type ski system with a minimum of three referencing stations mounted on the milling machine at a length of at least 24 feet.

ASPHALT CONCRETE PLANT MIX PAVEMENTS:

(2-20-18) (Rev. 7-18-23)

610, 1012

SP6 R65

Revise the *2018 Standard Specifications* as follows:

Page 6-14, Table 609-3, LIMITS OF PRECISION FOR TEST RESULTS, replace with the following:

Mix Property	Limits of Precision
25.0 mm sieve (Base Mix)	± 10.0%
19.0 mm sieve (Base Mix)	± 10.0%
12.5 mm sieve (Intermediate & Type P-57)	± 6.0%
9.5 mm sieve (Surface Mix)	± 5.0%
4.75 mm sieve (Surface Mix)	± 5.0%
2.36 mm sieve (All Mixes, except S4.75A)	± 5.0%
1.18 mm sieve (S4.75A)	± 5.0%
0.075 mm sieve (All Mixes)	± 2.0%
Asphalt Binder Content	± 0.5%
Maximum Specific Gravity (G_{mm})	± 0.020
Bulk Specific Gravity (G_{mb})	± 0.030
TSR	± 15.0%

QA retest of prepared QC Gyratory Compacted Volumetric Specimens	± 0.015
Retest of QC Core Sample	± 1.2% (% Compaction)
Comparison QA Core Sample	± 2.0% (% Compaction)
QA Verification Core Sample	± 2.0% (% Compaction)
Density Gauge Comparison of QC Test	± 2.0% (% Compaction)
QA Density Gauge Verification Test	± 2.0% (% Compaction)

Page 6-17, Table 610-1, MIXING TEMPERATURE AT THE ASPHALT PLANT, replace with the following:

Binder Grade	JMF Temperature
PG 58-28; PG 64-22	250 - 290°F
PG 76-22	300 - 325°F

Page 6-17, Subarticle 610-3(C), Job Mix Formula (JMF), lines 38-39, delete the fourth paragraph.

Page 6-18, Subarticle 610-3(C), Job Mix Formula (JMF), line 12, replace “SF9.5A” with “S9.5B”.

Page 6-18, Table 610-3, MIX DESIGN CRITERIA, replace with the following:

Mix Type	Design ESALs millions ^A	Binder PG Grade	Compaction Levels		Max. Rut Depth (mm)	Volumetric Properties ^B			
			G _{mm} @			VMA % Min.	VTM %	VFA Min.-Max.	%G _{mm} @ N _{ini}
			N _{ini}	N _{des}					
S4.75A	< 1	64 - 22	6	50	11.5	16.0	4.0 - 6.0	65 - 80	≤ 91.5
S9.5B	0 - 3	64 - 22	6	50	9.5	16.0	3.0 - 5.0	70 - 80	≤ 91.5
S9.5C	3 - 30	64 - 22	7	65	6.5	15.5	3.0 - 5.0	65 - 78	≤ 90.5
S9.5D	> 30	76 - 22	8	100	4.5	15.5	3.0 - 5.0	65 - 78	≤ 90.0
I19.0C	ALL	64 - 22	7	65	-	13.5	3.0 - 5.0	65 - 78	≤ 90.5
B25.0C	ALL	64 - 22	7	65	-	12.5	3.0 - 5.0	65 - 78	≤ 90.5
Design Parameter						Design Criteria			
All Mix Types	Dust to Binder Ratio (P _{0.075} / P _{be})					0.6 - 1.4 ^C			
	Tensile Strength Ratio (TSR) ^D					85% Min. ^E			

A. Based on 20 year design traffic.

B. Volumetric Properties based on specimens compacted to N_{des} as modified by the Department.

C. Dust to Binder Ratio (P_{0.075} / P_{be}) for Type S4.75A is 1.0 - 2.0.

D. NCDOT-T-283 (No Freeze-Thaw cycle required).

E. TSR for Type S4.75A & B25.0C mixes is 80% minimum.

Page 6-19, Table 610-5, BINDER GRADE REQUIREMENTS (BASED ON RBR%), replace with the following:

Mix Type	%RBR \leq 20%	21% \leq %RBR \leq 30%	%RBR > 30%
S4.75A, S9.5B, S9.5C, I19.0C, B25.0C	PG 64-22	PG 64-22 ^A	PG-58-28
S9.5D, OGFC	PG 76-22 ^B	n/a	n/a

A. If the mix contains any amount of RAS, the virgin binder shall be PG 58-28.

B. Maximum Recycled Binder Replacement (%RBR) is 18% for mixes using PG 76-22 binder.

Page 6-20, Table 610-6, PLACEMENT TEMPERATURES FOR ASPHALT, replace with the following:

Asphalt Concrete Mix Type	Minimum Surface and Air Temperature
B25.0C	35°F
I19.0C	35°F
S4.75A, S9.5B, S9.5C	40°F ^A
S9.5D	50°F

A. For the final layer of surface mixes containing recycled asphalt shingles (RAS), the minimum surface and air temperature shall be 50°F.

Page 6-21, Article 610-8, SPREADING AND FINISHING, lines 34-35, delete the second sentence and replace with the following:

Use an MTV for all surface mix regardless of binder grade on Interstates, US Routes, and NC Routes (primary routes) that have 4 or more lanes and are median divided.

Page 6-21, Article 610-8, SPREADING AND FINISHING, lines 36-38, delete the fourth sentence and replace with the following:

Use MTV for all ramps, loops, and Y-lines that have 4 or more lanes and are median divided, and all full width acceleration lanes, full width deceleration lanes, and full width turn lanes that are greater than 1000 feet in length.

Page 6-23, Table 610-7, DENSITY REQUIREMENTS, replace with the following:

Mix Type	Minimum % G_{mm} (Maximum Specific Gravity)
S4.75A	85.0 ^A
S9.5B	90.0
S9.5C, S9.5D, I19.0C, B25.0C	92.0

A. Compaction to the above specified density shall be required when the S4.75A mix is applied at a rate of 100 lbs/sy or higher.

Page 6-24, Article 610-13, FINAL SURFACE TESTING, lines 35-36, delete the second sentence and replace with the following:

Final surface testing is not required on ramps, loops and turn lanes.

Page 6-26, Subarticle 610-13(A)(1), Acceptance for New Construction, lines 29-30, delete the second sentence and replace with the following:

Areas excluded from testing by the profiler may be tested using a 10-foot straightedge in accordance with Article 610-12.

Page 6-27, Subarticle 610-13(B), Option 2- North Carolina Hearne Straightedge, lines 41-46, delete the eighth and ninth sentence of this paragraph and replace with the following:

Take profiles over the entire length of the final surface travel lane pavement exclusive of structures, approach slabs, paved shoulders, tapers, or other irregular shaped areas of pavement, unless otherwise approved by the Engineer. Test in accordance with this provision all mainline travel lanes, full width acceleration or deceleration lanes and collector lanes.

Page 6-28, Subarticle 610-13(B), Option 2- North Carolina Hearne Straightedge, lines 1-2, delete these two lines.

Page 6-32, Article 610-16 MEASUREMENT AND PAYMENT, replace with the following:

Pay Item	Pay Unit
Asphalt Concrete Base Course, Type B25.0C	Ton
Asphalt Concrete Intermediate Course, Type I19.0C	Ton
Asphalt Concrete Surface Course, Type S4.75A	Ton
Asphalt Concrete Surface Course, Type S9.5B	Ton
Asphalt Concrete Surface Course, Type S9.5C	Ton
Asphalt Concrete Surface Course, Type S9.5D	Ton

Page 10-30, Table 1012-1, AGGREGATE CONSENSUS PROPERTIES, replace with the following:

**TABLE 1012-1
AGGREGATE CONSENSUS PROPERTIES^A**

Mix Type	Coarse Aggregate Angularity^B	Fine Aggregate Angularity % Minimum	Sand Equivalent % Minimum	Flat and Elongated 5 : 1 Ratio % Maximum
<i>Test Method</i>	<i>ASTM D5821</i>	<i>AASHTO T 304</i>	<i>AASHTO T 176</i>	<i>ASTM D4791</i>
S4.75A; S9.5B	75 / -	40	40	-
S9.5C; I19.0C; B25.0C	95 / 90	45	45	10
S9.5D	100 / 100	45	50	10
OGFC	100 / 100	45	45	10
UBWC	100 / 85	45	45	10

A. Requirements apply to the design aggregate blend.

B. 95 / 90 denotes that 95% of the coarse aggregate has one fractured face and 90% has 2 or more fractured faces.

Page 10-30, Subarticle 1012-1(B)(6), Toughness (Resistance to Abrasion), line 12, replace “OGAFC” with “OGFC”.

TRENCHING FOR BASE COURSE:

(7-1-95) (Rev.1-19-16)

610

SP6 R79AR

Perform all trenching necessary to place the asphalt concrete base course widening in accordance with the typical sections, at locations shown on the sketch maps, and as directed by the Engineer.

Perform the trenching for the base course on the same day that the base course is to be placed. If the base course cannot be placed on the same day the trench section is excavated, backfill the trench with earth material and compact it to the satisfaction of the Engineer. Once the trench is open, perform backfilling and re-opening of the trench at no cost to the Department.

The Contractor will be restricted to widening one side of the project at a time unless otherwise permitted by the Engineer. In widening, operate equipment and conduct operations in the same direction as the flow of traffic.

Compact the asphalt concrete base course in the widened areas using means and methods acceptable to the Engineer. Density testing will be performed in accordance with Section 10.3.4 of the *QMS Manual*.

Place the excavated material from trenching operation on the adjacent shoulder area as directed by the Engineer. Cut adequate weep holes in the excavated material to provide for adequate drainage as directed by the Engineer. Remove all excavated material from all drives to provide ingress and egress to abutting properties and from in front of mailboxes and paper boxes. Saw a neat edge and remove all asphalt and/or concrete driveways, and existing asphalt widening, as directed by the Engineer, to the width of the widening and dispose of any excavated concrete or asphalt materials. Properly reconnect driveways.

Upon completion of the paving operation, backfill the trench to the satisfaction of the Engineer. Properly dispose of any excess material remaining after this operation.

No direct payment will be made for trenching, sawing, and removal of driveways, depositing material on shoulder area, backfilling trench, or removal of spoil material, as the cost of this work shall be included in the bid unit price per ton for *Asphalt Concrete Base Course, Type ____*.

SUPPLEMENTAL SURVEYING:

(4-20-21)

801

SP8 R03

Revise the *2018 Standard Specifications* as follows:

Page 8-7, Article 801-3 MEASUREMENT AND PAYMENT, lines 10-11, replace with the following:

Supplemental Surveying Office Calculations will be paid at the stated price of \$85.00 per hour. *Supplemental Field Surveying* will be paid at the stated price of \$145.00 per hour. The

CONCRETE APRON FOR DROP INLET:

Construct concrete aprons for drop inlets in accordance with this provision, *Roadway Standard Drawings* 840.17, 840.18, and 840.19, and section 840 of the *Standard Specifications*, at locations as directed by the Engineer.

Measurement and Payment

Payment for the work shall be made on a per each basis completed and accepted by the Engineer. The cost for removal and disposal of the existing drop inlet apron shall be considered incidental to the work and shall be included in the cost of the new apron.

Payment will be made under:

Pay Item	Pay Unit
Concrete Apron for Drop Inlet	Each

GUARDRAIL END UNITS & TEMPORARY GUARDRAIL END UNITS, TYPE - TL-3:

(4-20-04) (Rev. 5-16-23)

862

SP8 R65

Description

Furnish and install guardrail end units in accordance with the details in the plans, the applicable requirements of Section 862 of the *Standard Specifications*, and at locations shown in the plans.

Materials

Furnish guardrail end units listed on the NCDOT APL. Units shall not be modified by the manufacturer and installer once approved and on the NCDOT APL.

Prior to installation the Contractor shall submit to the Engineer certified working drawings and assembling instructions from the manufacturer for each guardrail end unit in accordance with Article 105-2 of the *Standard Specifications*.

Perform installation in accordance with the details in the plans, and details and assembling instructions furnished by the manufacturer.

Construction Methods

Guardrail end delineation is required on all approach and trailing end sections for both temporary and permanent installations. Guardrail end delineation consists of yellow reflective sheeting applied to the entire end section of the guardrail in accordance with Article 1088-3 of the *Standard Specifications* and is incidental to the cost of the guardrail end unit.

Measurement and Payment

Measurement and payment will be made in accordance with Article 862-6 of the *Standard Specifications*.

Payment will be made under:

Pay Item	Pay Unit
Guardrail End Units, Type TL-3	Each
Temporary Guardrail End Units, Type TL-3	Each

GUARDRAIL ANCHOR UNITS AND TEMPORARY GUARDRAIL ANCHOR UNITS:

(1-16-2018)

862

SP8 R70

Guardrail anchor units will be in accordance with the details in the plans and the applicable requirements of Section 862 of the *2018 Standard Specifications*.

Revise the *2018 Standard Specifications* as follows:

Page 8-42, Article 862-6 MEASUREMENT AND PAYMENT, add the following:

Guardrail Anchor Units, Type ___ and Temporary Guardrail Anchor Units Type ___ will be measured and paid as units of each completed and accepted. No separate measurement will be made of any rail, terminal sections, posts, offset blocks, concrete, hardware or any other components of the completed unit that are within the pay limits shown in the plans for the unit as all such components will be considered to be part of the unit.

Payment will be made under:

Pay Item	Pay Unit
Guardrail Anchor Units, Type ___	Each
Temporary Guardrail Anchor Units, Type ___	Each

IMPACT ATTENUATOR UNITS, TYPE TL-3:

(4-20-04)(Rev. 10-17-23)

SP8 R75

Description

Furnish and install impact attenuator units and any components necessary to connect the impact attenuator units in accordance with the manufacturer's requirement, the details in the plans and at locations shown in the plans.

Materials

Furnish attenuator units listed on the NCDOT APL. Units shall not be modified by the manufacturer and installer once approved and on the NCDOT APL.

Prior to installation the Contractor shall submit to the Engineer certified working drawings and assembling instructions from the manufacturer for each impact attenuator unit in accordance with Article 105-2 of the *Standard Specifications*.

Construction Methods

Perform installation in accordance with the plans and details and assembling instructions furnished by the manufacturer.

Measurement and Payment

Impact Attenuator Unit, Type TL-3 will be measured and paid at the contract unit price per each. Such prices and payment will be full compensation for all work covered by this provision including, but not limited to, furnishing, installing and all incidentals necessary to complete the work.

Payment will be made under:

Pay Item	Pay Unit
Impact Attenuator Units, Type TL-3	Each

ADJUSTMENT OF CATCH BASINS, MANHOLES, DROP INLETS, METER BOXES AND VALVE BOXES:

(11-15-22) 858 SP8 R98R

Revise the *2018 Standard Specifications* as follows:

Page 8-38, Article 858-4 MEASUREMENT AND PAYMENT, lines 10-11, delete and replace the fifth paragraph with the following:

Where any catch basin, drop inlet, manhole, meter box or valve box is adjusted more than once because of milling operations, each adjustment will be measured and paid.

PORTLAND CEMENT CONCRETE PRODUCTION AND DELIVERY:

(9-15-20) 1000, 1014, 1024 SP10 R01

Revise the *2018 Standard Specifications* as follows:

Page 10-6, Table 1000-1, REQUIREMENTS FOR CONCRETE, replace with the following:

TABLE 1000-1 REQUIREMENTS FOR CONCRETE											
Class of Concrete	Min. Compressive Strength at 28 days	Maximum Water-Cement Ratio				Consistency Maximum Slump		Cement Content			
		Air-Entrained Concrete		Non-Air-Entrained Concrete		Vibrated	Non-Vibrated	Vibrated		Non-Vibrated	
		Rounded Aggregate	Angular Aggregate	Rounded Aggregate	Angular Aggregate			Min.	Max.	Min.	Max.
		<i>Units</i>	<i>psi</i>					<i>inch</i>	<i>inch</i>	<i>lb/cy</i>	<i>lb/cy</i>
AA	4500	0.381	0.426	---	---	3.5 ^A	---	639	715	---	---
AA Slip Form	4500	0.381	0.426	---	---	1.5	---	639	715	---	---
Drilled Pier	4500	---	---	0.450	0.450	---	5 - 7 dry	---	---	640	800
A	3000	0.488	0.532	0.550	0.594	3.5 ^A	4.0	564	---	602	---

B	2500	0.488	0.567	0.559	0.630	1.5 machine placed 2.5 ^A hand placed	4.0	508	---	545	---
Sand Light-weight	4500	---	0.420	---	---	4.0 ^A	---	715	---	---	---
Latex Modified	3000 (at 7 days)	0.400	0.400	---	---	6.0	---	658	---	---	---
Flowable Fill excavatable	150 max. (at 56 days)	as needed	as needed	as needed	as needed	---	Flowable	---	---	40	100
Flowable Fill non- excavatable	125	as needed	as needed	as needed	as needed	---	Flowable	---	---	100	as needed
Pavement	4500 Design, field 650 flexural, design only	0.559	0.559	---	---	1.5 slip form 3.0 hand placed	---	526	---	---	---
Precast	See Table 1077-1	as needed	as needed	---	---	6.0	as needed	as needed	as needed	as needed	as needed
Prestressed	per contract	See Table 1078-1	See Table 1078-1	---	---	8.0	---	564	as needed	---	---

- A.** The slump may be increased to 6 inches, provided the increase in slump is achieved by adding a chemical admixture conforming to Section 1024-3. In no case shall the water-cement ratio on the approved design be exceeded. Concrete exhibiting segregation and/or excessive bleeding will be rejected. Utilizing an Admixture to modify slump does not relinquish the contractor's responsibility to ensure the final product quality and overall configuration meets design specifications. Caution should be taken when placing these modified mixes on steep grades to prevent unintended changes to the set slope.

THERMOPLASTIC INTERMIXED BEAD TESTING:

7-19-22

1087

SP10 R04

Revise the *2018 Standard Specifications* as follows:

Page 10-183, Subarticle 1087-7(B) Thermoplastic Pavement Marking Material Composition, delete line 34 and 35.

Page 10-184, Article 1087-8 MATERIAL CERTIFICATION, delete and replace with the following after line 34:

Drop-on Glass Beads	Type 3 Material Certification and Type 4 Material Certification
Intermix Glass Beads	Type 2 Material Certification and Type 3 Material Certification
Paint	Type 3 Material Certification
Removable Tape	Type 3 Material Certification
Thermoplastic	Type 3 Material Certification and Type 4 Material Certification
Cold Applied Plastic	Type 2 Material Certification and Type 3 Material Certification
Polyurea	Type 2 Material Certification and Type 3 Material Certification

THERMOPLASTIC PAVEMENT MARKING MATERIAL – COLOR TESTING:

3-19-19

1087

SP10 R05

Revise the *2018 Standard Specifications* as follows:

Pages 10-183 and 10-184, Subarticle 1087-7(D)(1)(b) Yellow, lines 9-11, delete and replace with the following:

Obtain Color Values Y,x,y per ASTM E1349 using C/2° illuminant/observer.
Results shall be $Y \geq 45\%$, and x,y shall fall within PR#1 chart chromaticity limits.

POLYUREA PAVEMENT MARKING MATERIAL – TYPE 2 TYPICAL CERTIFIED MILL TEST REPORT:

3-19-19

1087

SP10 R06

Amend the *2018 Standard Specifications* as follows:

Page 10-184, Subarticle 1087-8 Material Certification, in accordance with Subarticle 106-3 provide a Type 2 Typical Certified Mill Test Report and a Type 3 Manufacturer’s Certification for Polyurea pavement marking material.

When tested, the material shall meet the physical and chemical characteristics provided by the manufacturer. NCDOT reserves the right to compare these test results to baseline test results gathered by the NCDOT Materials and Test Unit.

NON-CAST IRON SNOWPLOWABLE PAVEMENT MARKERS:

10-19-21 (Rev. 11-16-21)

1086, 1250, 1253

SP10 R08

Revise the *2018 Standard Specifications* as follows:

Pages 10-177 and 10-178, Subarticle 1086-3 SNOWPLOWABLE PAVEMENT MARKERS, delete items (A), (B) and (C)(1) and replace with the following:

(A) General

Use non-cast iron snowplowable pavement markers evaluated by NTPEP. The non-cast iron snowplowable pavement marker shall consist of a housing with one or more glass or plastic face lens type reflective lenses to provide the required color designation. The marker shall be designed or installed in a manner that minimizes damage from snowplow blades. Plastic lens faces shall use an abrasion resistant coating.

(B) Housings

(1) Dimensions

The dimension, slope and minimum area of reflecting surface shall conform to dimensions as shown in the plans. The minimum area of each reflecting surface shall be 1.44 sq.in.

(2) Materials

Use non-cast iron snowplowable pavement markers that are on the NCDOT Approved Products List.

(3) Surface

The surface of the housing shall be free of scale, dirt, rust, oil, grease or any other contaminant which might reduce its bond to the epoxy adhesive.

(4) Identification

Mark the housing with the manufacturer's name and model number of marker.

(C) Reflectors

(1) General

Laminate the reflector to an elastomeric pad and attach with adhesive to the housing. The thickness of the elastomeric pad shall be 0.04".

Pages 12-14, Subarticle 1250-3(C) Removal of Existing Pavement Markers, lines 19-29, delete and replace with the following:

Remove the existing raised pavement markers or the snowplowable pavement markers including the housings, before overlaying an existing roadway with pavement. Repair the pavement by filling holes as directed by the Engineer.

When traffic patterns are changed in work zones due to construction or reconstruction, remove all raised pavement markers or snowplowable markers including housings that conflict with the new traffic pattern before switching traffic to the new traffic pattern. Lens removal in lieu of total housing removal is not an acceptable practice for snowplowable markers.

Properly dispose of the removed pavement markers. No direct payment will be made for removal or disposal of existing pavement markers or repair of pavement, as such work will be incidental to other items in the contract.

Pages 12-16, Subarticle 1253-1 DESCRIPTION, lines 4-5, delete and replace with the following:

Furnish, install and maintain non-cast iron snowplowable pavement markers in accordance with the contract.

Pages 12-16 and 12-17, Subarticle 1253-3 CONSTRUCTION METHODS, delete items (A), (B) and (C) and replace with the following:

(A) General

Bond marker housings to the pavement with epoxy adhesive. Mechanically mix and dispense epoxy adhesives as required by the manufacturer's specifications. Place the markers immediately after the adhesive has been mixed and dispensed.

If saw cutting, milling, or grooving operations are used, promptly remove all resulting debris from the pavement surface. Install the marker housings within 7 calendar days after saw cutting, milling, or grooving the pavement. Remove and dispose of loose material from the slots by brushing, blow cleaning, or vacuuming. Dry the slots before applying the epoxy adhesive. Install non-cast iron snowplowable pavement markers according to the manufacturer's recommendations.

Protect the non-cast iron snowplowable pavement markers until the epoxy has initially cured and is track free.

(B) Reflector Replacement

In the event that a reflector is damaged, replace the damaged reflector by using adhesives and methods recommended by the manufacturer of the markers and approved by the Engineer. This work is considered incidental if damage occurs during the initial installation of the marker housings and maintenance of initial non-cast iron snowplowable markers specified in this section. This work will be paid for under the pay item for the type of reflector replacement if the damage occurred after the initial installation of the non-cast iron snowplowable pavement marker.

Missing housings shall be replaced. Broken housings shall be removed and replaced. In both cases the slot for the housings shall be properly prepared prior to installing the new housing; patch the existing marker slots as directed by the Engineer and install the new marker approximately one foot before or after the patch. Removal of broken housings and preparation of slots will be considered incidental to the work of replacing housings.

Pages 12-17, Subarticle 1253-4 MAINTENANCE, lines 5, delete and replace with the following:

Maintain all installed non-cast iron snowplowable pavement markers until acceptance.

Pages 12-17, Subarticle 1253-5 MEASUREMENT AND PAYMENT, lines 7-8, delete and replace with the following:

Non-Cast Iron Snowplowable Pavement Markers will be measured and paid as the actual number of non-cast iron snowplowable pavement markers satisfactorily placed and accepted by the Engineer.

Pages 12-17, Subarticle 1253-5 MEASUREMENT AND PAYMENT, lines 11, delete and replace with the following:

Payment will be made under:

Pay Item	Pay Unit
Non-Cast Iron Snowplowable Pavement Marker	Each
Replace Snowplowable Pavement Marker Reflector	Each

MATERIALS FOR PORTLAND CEMENT CONCRETE:

(9-15-20)

1000, 1024

SP10 R24

Revise the *2018 Standard Specifications* as follows:

Page 10-52, Article 1024-4, WATER, lines 3-6, delete and replace with the following:

Test water from wells at all locations. Test public water supplies from all out of state locations and in the following counties: Beaufort, Bertie, Brunswick, Camden, Carteret, Chowan, Craven, Currituck, Dare, Gates, Hyde, New Hanover, Onslow, Pamlico, Pasquotank, Pender, Perquimans, Tyrell and Washington unless the Engineer waives the testing requirements.

Page 10-52, Table 1024-2, PHYSICAL PROPERTIES OF WATER, replace with the following:

Property	Requirement	Test Method
Compression Strength, minimum percent of control at 3 and 7 days	90%	ASTM C1602
Time of set, deviation from control	From 1:00 hr. earlier to 1:30 hr. later	ASTM C1602
pH	4.5 to 8.5	ASTM D1293 *
Chloride Ion Content, Max.	250 ppm	ASTM D512 *
Total Solids Content (Residue), Max.	1,000 ppm	SM 2540B *
Resistivity, Min.	0.500 kohm-cm	ASTM D1125 *

*Denotes an alternate method is acceptable. Test method used shall be referenced in the test report.

GEOSYNTHETICS:

(03-21-23)(Rev. 4-18-23)

1056

SP10 R56

Revise the *Standard Specifications* as follows:

Page 10-77, Article 1056-1 DESCRIPTION, lines 13-16, delete and replace the second sentence in the second paragraph with the following:

Steel anchor pins shall have a diameter of at least 3/16 inch, a length of at least 18 inches, a point at one end and a head at the other end that will retain a steel washer with an outside diameter of at least 1.5 inches.

Page 10-77, Article 1056-2 HANDLING AND STORING, lines 20-21, delete and replace the third sentence in the first paragraph with the following:

Geosynthetics with defects, flaws, deterioration or damage will be rejected by the Engineer.

Page 10-77, Article 1056-3 CERTIFICATIONS AND IDENTIFICATION, lines 25-27, delete and replace the first sentence in the first paragraph with the following:

Provide Type 1, Type 2 or Type 4 material certifications in accordance with Article 106-3 for geosynthetics except certifications are not required for Type 1 through Type 5 geotextiles.

Page 10-77, Article 1056-3 CERTIFICATIONS AND IDENTIFICATION, lines 32-35, delete the second paragraph.

Page 10-77, Article 1056-3 CERTIFICATIONS AND IDENTIFICATION, lines 36-41, delete and replace the third paragraph with the following:

Allow the Engineer to visually identify geosynthetic products before installation. Open packaged geosynthetics just before use in the presence of the Engineer to verify the correct product. Geosynthetics that are missing original packaging or product labels or that have been unwrapped or previously opened will be rejected unless otherwise approved by the Engineer.

Page 10-77, Article 1056-4 GEOTEXTILES, lines 43-45, delete the first paragraph.

Page 10-78, Article 1056-4 GEOTEXTILES, before line 1 and lines 1-5, delete Table 1056-1 and lines 1-5 and replace with the following:

TABLE 1056-1 GEOTEXTILE REQUIREMENTS						
Property ^A	Requirement (MARV ^A)					Test Method
	Type 1	Type 2	Type 3 ^B	Type 4	Type 5 ^C	
<i>Typical Application</i>	<i>Shoulder Drains</i>	<i>Under Rip Rap</i>	<i>Silt Fence Fabric</i>	<i>Soil Stabilization</i>	<i>Subgrade Stabilization</i>	
Elongation (MD & CD)	≥ 50%	≥ 50%	≤ 25%	< 50%	< 50%	ASTM D4632
Grab Strength (MD & CD) ^A	Table 1 ^D , Class 3	Table 1 ^D , Class 1	100 lb	Table 1 ^D , Class 3	-	ASTM D4632
Tear Strength (MD & CD) ^A			-			ASTM D4533
Puncture Strength			-			ASTM D6241
Ultimate Tensile Strength (MD & CD) ^A	-	-	-	-	Table 12 ^D , Class 4A	ASTM D4595
Permittivity	Table 2 ^D , 15% to 50% <i>in Situ</i> Soil Passing 0.075 mm	Table 6 ^D , 15% to 50% <i>in Situ</i> Soil Passing 0.075 mm	Table 7 ^D	Table 5 ^D	Table 12 ^D , Class 4A	ASTM D4491
Apparent Opening Size						ASTM D4751
UV Stability (Retained Strength)						ASTM D4355

A. MD, CD and MARV per Article 1056-3.

B. Minimum roll width of 36 inches required.

C. Minimum roll width of 13 feet required unless otherwise approved by the Engineer for the application.

D. Per AASHTO M 288.

Page 10-78, Article 1056-5 GEOCOMPOSITE DRAINS, before line 9 and lines 9-10, delete Table 1056-2 and lines 9-10 and replace with the following:

TABLE 1056-2 GEOCOMPOSITE DRAIN REQUIREMENTS				
Property	Requirement			Test Method
	Sheet Drain	Strip Drain	Wick Drain	
Width	≥ 12"	12" ±1/4"	4" ±1/4"	N/A
In-Plane Flow Rate ^A (with gradient of 1.0 and 24-hour seating period)	6 gpm/ft @ applied normal compressive stress of 10 psi	15 gpm/ft @ applied normal compressive stress of 7.26 psi	1.5 gpm ^B @ applied normal compressive stress of 1.45 psi	ASTM D4716

A. MARV per Article 1056-3.

B. Per foot of width tested.

Page 10-79, Article 1056-5 GEOCOMPOSITE DRAINS, before line 3, delete Table 1056-3 and replace with the following:

TABLE 1056-3 DRAINAGE CORE REQUIREMENTS			
Property	Requirement		Test Method
	Sheet Drain	Strip Drain	
Thickness	1/4"	1"	ASTM D1777 or D5199
Compressive Strength ^A	40 psi	30 psi	ASTM D6364

A. MARV per Article 1056-3.

Page 10-79, Article 1056-5 GEOCOMPOSITE DRAINS, before line 6 and lines 6-11, delete Table 1056-4, lines 6-7 and the last paragraph and replace with the following:

TABLE 1056-4 WICK DRAIN GEOTEXTILE REQUIREMENTS		
Property	Requirement	Test Method
Elongation	≥ 50%	ASTM D4632
Grab Strength	Table 1 ^A , Class 3	ASTM D4632
Tear Strength		ASTM D4533
Puncture Strength		ASTM D6241
Permittivity ^B	0.7 sec ⁻¹	ASTM D4491
Apparent Opening Size (AOS)	Table 2 ^A , > 50% <i>in Situ</i> Soil Passing 0.075 mm	ASTM D4751
UV Stability (Retained Strength)		ASTM D4355

A. Per AASHTO M 288.

B. MARV per Article 1056-3.

For wick drains with a geotextile fused to both faces of a corrugated drainage core along the peaks of the corrugations, use wick drains with an ultimate tensile strength of at least 1,650 lbs. per 4 inch width in accordance with ASTM D4595 and geotextiles with a permittivity, AOS and UV stability that meet Table 1056-4.

Page 10-80, Article 1056-6 GEOCELLS, before line 1 and lines 1-4, delete Table 1056-5 and lines 1-4 and replace with the following:

TABLE 1056-5 GEOCELL REQUIREMENTS		
Property	Requirement	Test Method
Cell Depth	4"	N/A
Fully Expanded Cell Area	100 sq.in. max	N/A
Sheet Thickness	50 mil -5%, +10%	ASTM D5199
Density	58.4 pcf min	ASTM D1505
Carbon Black Content	1.5% min	ASTM D1603 or D4218
ESCR ^A	5000 hr min	ASTM D1693
Coefficient of Direct Sliding (with material that meets AASHTO M 145 for soil classification A-2)	0.85 min	ASTM D5321
Short-Term Seam (Peel) Strength (for 4" seam)	320 lb min	USACE ^C Technical Report GL-86-19, Appendix A
Long-Term Seam (Hang) Strength ^B (for 4" seam)	160 lb min	

A. Environmental Stress Crack Resistance.

B. Minimum test period of 168 hours with a temperature change from 74°F to 130°F in 1-hour cycles.

C. US Army Corps of Engineers (USACE).

MATERIAL AND EQUIPMENT STORAGE & PARKING OF PERSONAL VEHICLES:

11-17-21(Rev. 8-16-22)

1101

SP11 R03

Revise the *2018 Standard Specifications* as follows:

Page 11-2, Article 1101-8 MATERIAL AND EQUIPMENT STORAGE, line 35-38, delete and replace with the following:

When work is not in progress, keep all personnel, equipment, machinery, tools, construction debris, materials and supplies away from active travel lanes that meets Table 1101-1.

TABLE 1101-1 MATERIAL AND EQUIPMENT STORAGE FROM ACTIVE TRAVEL LANES	
Posted Speed Limit (mph)	Distance (ft)
40 or less	≥ 18
45-50	≥ 28
55	≥ 32
60 or higher	≥ 40

When vehicles, equipment and materials are protected by concrete barrier or guardrail, they shall be offset at least 5 feet from the barrier or guardrail.

Page 11-2, Article 1101-9 PARKING OF PERSONAL VEHICLES, line 40-41, delete and replace with the following:

Provide staging areas for personal vehicle parking in accordance with Article 1101-8 or as directed by the Engineer before use.

WORK ZONE INSTALLER:

(7-20-21)(Rev. 8-16-22)

1101, 1150

SP11 R04

Provide the service of at least one qualified work zone installer during the setup, installation, and removal of temporary traffic control within the highway right of way. The qualified work zone installer shall serve as crew leader and shall be on site and directing the installation and removal of temporary traffic control. If multiple temporary traffic control installations or removals are occurring simultaneously, then each shall have a qualified work zone installer.

The work zone installer shall be qualified by an NCDOT approved training agency or other NCDOT approved training provider in the safe and competent set up of temporary traffic control. For a complete listing of approved training agencies, see the Work Zone Safety Training webpage.

A work zone supervisor, in accordance with Article 1101-13 of the *Standard Specifications*, may fulfill the role of the work zone installer during the setup, installation, and removal of temporary traffic control within the highway right of way provided they are on site and directing the installation and removal of temporary traffic control.

All other individuals participating in the setup, installation, and removal of temporary traffic control within the highway right of way shall be certified as a qualified flagger in accordance with Article 1150-3 of the *Standard Specifications*, even if flagging is not being performed as part of the traffic control.

Provide the name and contact information of all qualified work zone installers to the Engineer prior to or at the preconstruction conference. Additionally, provide a qualification statement that all other individuals participating in the setup, installation, and removal of temporary traffic control are qualified flaggers that have been properly trained through an NCDOT approved training agency or other NCDOT approved training provider.

All certification records for qualified work zone installers and flaggers shall be uploaded by the approved training agency or other NCDOT approved training provider to the Department's Work Zone Education Verification App (WZ-EVA) prior to the qualified work zone installer or flagger performing any traffic control duties on the project. For more information about WZ-EVA, see the Work Zone Safety Training webpage.

EXTRUDED THERMOPLASTIC PAVEMENT MARKING THICKNESS:

3-19-19 (Rev. 6-21-22)

1205

SP12 R05

Revise the *2018 Standard Specifications* as follows:

Page 12-6, Subarticle 1205-4(A)(1) General, lines 5-8, delete the second sentence and replace with the following:

Use application equipment that provides multiple width settings ranging from 4 inches to 12 inches and multiple thickness settings to achieve the required thickness above the surface of the pavement as shown in Table 1205-3.

Page 12-7, Table 1205-3, THICKNESS REQUIREMENTS FOR THERMOPLASTIC, replace with the following:

TABLE 1205-3 MINIMUM THICKNESS REQUIREMENTS FOR THERMOPLASTIC	
Thickness	Location
240 mils	In-lane and shoulder-transverse pavement markings (rumble strips). May be placed in 2 passes.
90 mils	Center lines, skip lines, transverse bands, mini-skip lines, characters, bike lane symbols, crosswalk lines, edge lines, gore lines, diagonals, and arrow symbols

PORTABLE CONSTRUCTION LIGHTING:

4-19-22

1413

SP14 R13

Revise the *2018 Standard Specifications* as follows:

Page 14-24, Article 1413-3 TOWER LIGHT, lines 2-7, delete and replace the first and second sentence in the first paragraph with the following:

Use tower lights which consist of mercury vapor, metal halide, high pressure sodium, low pressure sodium or light emitting diode (with correlated color temperature of 4000 Kelvin or less) fixtures mounted on a tower approximately 30 feet in height. Use tower light fixtures which are heavy duty flood, area, or roadway style with wide beam spread, have sufficient output to provide the minimum illumination requirements for the Category of work, are weatherproof and supplied with attached waterproof power cord and plug.

Page 14-24, Article 1413-3 TOWER LIGHT, lines 11-12, delete and replace the second paragraph with the following:

Provide tower lights of sufficient wattage or quantity to provide the minimum average maintained horizontal illuminance over the work area based on the Category of work as shown in Table 1413-1. For any work not covered in Table 1413-1, provide a minimum average maintained horizontal illuminance of 20.0 footcandles over the work area.

TABLE 1413-1 MINIMUM ILLUMINATION REQUIREMENTS FOR PORTABLE CONSTRUCTION LIGHTING		
Category	Description of Construction and Maintenance Task	Minimum Average Maintained Horizontal Illuminance
I	Excavation; Embankment, Fill and Compaction; Maintenance of Embankment; Asphalt Pavement Rolling; Subgrade, Stabilization and Construction; Base Course Rolling; Sweeping and Cleaning; Landscaping, Sod and Seeding; Reworking Shoulders.	5.0 footcandle
II	Barrier Wall and Traffic Separators; Milling, Removal of Pavement; Asphalt Paving and Resurfacing; Concrete Pavement; Base Course Grading and Shaping; Surface Treatment; Waterproofing and Sealing; Sidewalk Construction; Guardrails and Fencing; Striping and Pavement Marking; Highway Signs; Bridge Decks; Drainage Structures and Drainage Piping; Other Concrete Structures; Repair of Concrete Pavement; Pothole Filling; Repair of Guardrail and Fencing.	10.0 footcandle
III	Traffic Signals; Highway Lighting Systems; Crack Filling.	20.0 footcandle

Page 14-24, Article 1413-4 MACHINE LIGHTS, lines 18-21, delete and replace the first and second sentence in the first paragraph with the following:

Use machine lights which have mercury vapor, metal halide, high pressure sodium, low pressure sodium or light emitting diode (with correlated color temperature of 4000 Kelvin or less) fixtures mounted on supports attached to the construction machine at a height of approximately 13 feet.

Page 14-24, Article 1413-5 CONSTRUCTION METHODS, lines 33-34, delete and replace the third and fourth sentence in the first paragraph with the following:

Submit photometric calculations showing the minimum average maintained horizontal illuminance over the work area and the tower spacing to the Engineer for review and approval prior to installation.

EROSION AND STORMWATER CONTROL FOR SHOULDER CONSTRUCTION AND RECONSTRUCTION:

(11-16-10) (Rev. 1-21-20)

105-16, 225-2, Division 16

SP16 R03R

Land disturbing operations associated with shoulder construction/reconstruction may require erosion and sediment control/stormwater measure installation. National Pollutant Discharge Elimination System (NPDES) inspection and reporting may be required.

Erosion control measures shall be installed per the erosion control detail in any area where the vegetated buffer between the disturbed area and surface waters (streams, wetlands, or open waters) or drainage inlet is less than 10 feet. The Engineer may reduce the vegetated buffer threshold for this requirement to a value between 5 and 10 feet. Erosion control measures shall be spot checked every 7 days until permanent vegetative establishment.

In areas where shoulder construction/reconstruction includes disturbance or grading on the front slope or to the toe of fill, relocating ditch line or backslope, or removing vegetation from the ditch line or swale, NPDES inspection and monitoring are required every 7 days or within 24 hours of a rainfall event of greater than 1.0 inch. Maintain daily rainfall records. Install erosion control measures per detail.

In areas where the vegetated buffer is less than 10 feet between the disturbed area and waters of the State classified as High Quality Water (HQW), Outstanding Resource Water (ORW), Critical Areas, or Unique Wetlands, NPDES inspection and monitoring are required every 7 days or within 24 hours of a rainfall event of greater than 1.0 inch. The Engineer may reduce the vegetated buffer threshold for this requirement to a value between 5 and 10 feet. The plans or provisions will indicate the presence of these water classifications. Maintain daily rainfall records. Install erosion control measures per detail.

Land disturbances hardened with aggregate materials receiving sheet flow are considered non-erodible.

Sites that require lengthy sections of silt fence may substitute with rapid permanent seeding and mulching as directed by the Engineer.

NPDES documentation shall be performed by a Level II Erosion and Sediment Control/Stormwater certificate holder.

Materials used for erosion control will be measured and paid as stated in the contract.

STANDARD SPECIAL PROVISION
AVAILABILITY OF FUNDS – TERMINATION OF CONTRACTS

(5-20-08)

Z-2

General Statute 143C-6-11. (h) Highway Appropriation is hereby incorporated verbatim in this contract as follows:

(h) Amounts Encumbered. – Transportation project appropriations may be encumbered in the amount of allotments made to the Department of Transportation by the Director for the estimated payments for transportation project contract work to be performed in the appropriation fiscal year. The allotments shall be multiyear allotments and shall be based on estimated revenues and shall be subject to the maximum contract authority contained in *General Statute 143C-6-11(c)*. Payment for transportation project work performed pursuant to contract in any fiscal year other than the current fiscal year is subject to appropriations by the General Assembly. Transportation project contracts shall contain a schedule of estimated completion progress, and any acceleration of this progress shall be subject to the approval of the Department of Transportation provided funds are available. The State reserves the right to terminate or suspend any transportation project contract, and any transportation project contract shall be so terminated or suspended if funds will not be available for payment of the work to be performed during that fiscal year pursuant to the contract. In the event of termination of any contract, the contractor shall be given a written notice of termination at least 60 days before completion of scheduled work for which funds are available. In the event of termination, the contractor shall be paid for the work already performed in accordance with the contract specifications.

Payment will be made on any contract terminated pursuant to the special provision in accordance with Subarticle 108-13(D) of the *2018 Standard Specifications*.

STANDARD SPECIAL PROVISION
NCDOT GENERAL SEED SPECIFICATION FOR SEED QUALITY

(5-17-11)

Z-3

Seed shall be sampled and tested by the North Carolina Department of Agriculture and Consumer Services, Seed Testing Laboratory. When said samples are collected, the vendor shall supply an independent laboratory report for each lot to be tested. Results from seed so sampled shall be final. Seed not meeting the specifications shall be rejected by the Department of Transportation and shall not be delivered to North Carolina Department of Transportation warehouses. If seed has been delivered it shall be available for pickup and replacement at the supplier's expense.

Any re-labeling required by the North Carolina Department of Agriculture and Consumer Services, Seed Testing Laboratory, that would cause the label to reflect as otherwise specified herein shall be rejected by the North Carolina Department of Transportation.

Seed shall be free from seeds of the noxious weeds Johnsongrass, Balloonvine, Jimsonweed, Witchweed, Itchgrass, Serrated Tussock, Showy Crotalaria, Smooth Crotalaria, Sicklepod, Sandbur, Wild Onion, and Wild Garlic. Seed shall not be labeled with the above weed species on the seed analysis label. Tolerances as applied by the Association of Official Seed Analysts will NOT be allowed for the above noxious weeds except for Wild Onion and Wild Garlic.

Tolerances established by the Association of Official Seed Analysts will generally be recognized. However, for the purpose of figuring pure live seed, the found pure seed and found germination percentages as reported by the North Carolina Department of Agriculture and Consumer Services, Seed Testing Laboratory will be used. Allowances, as established by the NCDOT, will be recognized for minimum pure live seed as listed on the following pages.

The specifications for restricted noxious weed seed refers to the number per pound as follows:

<u>Restricted Noxious Weed</u>	<u>Limitations per Lb. Of Seed</u>	<u>Restricted Noxious Weed</u>	<u>Limitations per Lb. of Seed</u>
Blessed Thistle	4 seeds	Cornflower (Ragged Robin)	27 seeds
Cocklebur	4 seeds	Texas Panicum	27 seeds
Spurred Anoda	4 seeds	Bracted Plantain	54 seeds
Velvetleaf	4 seeds	Buckhorn Plantain	54 seeds
Morning-glory	8 seeds	Broadleaf Dock	54 seeds
Corn Cockle	10 seeds	Curly Dock	54 seeds
Wild Radish	12 seeds	Dodder	54 seeds
Purple Nutsedge	27 seeds	Giant Foxtail	54 seeds
Yellow Nutsedge	27 seeds	Horsenettle	54 seeds
Canada Thistle	27 seeds	Quackgrass	54 seeds
Field Bindweed	27 seeds	Wild Mustard	54 seeds
Hedge Bindweed	27 seeds		

Seed of Pensacola Bahiagrass shall not contain more than 7% inert matter, Kentucky Bluegrass, Centipede and Fine or Hard Fescue shall not contain more than 5% inert matter whereas a maximum of 2% inert matter will be allowed on all other kinds of seed. In addition, all seed shall not contain more than 2% other crop seed nor more than 1% total weed seed. The germination

rate as tested by the North Carolina Department of Agriculture shall not fall below 70%, which includes both dormant and hard seed. Seed shall be labeled with not more than 7%, 5% or 2% inert matter (according to above specifications), 2% other crop seed and 1% total weed seed.

Exceptions may be made for minimum pure live seed allowances when cases of seed variety shortages are verified. Pure live seed percentages will be applied in a verified shortage situation. Those purchase orders of deficient seed lots will be credited with the percentage that the seed is deficient.

FURTHER SPECIFICATIONS FOR EACH SEED GROUP ARE GIVEN BELOW:

Minimum 85% pure live seed; maximum 1% total weed seed; maximum 2% total other crop seed; maximum 144 restricted noxious weed seed per pound. Seed less than 83% pure live seed will not be approved.

Sericea Lespedeza
Oats (seeds)

Minimum 80% pure live seed; maximum 1% total weed seed; maximum 2% total other crop; maximum 144 restricted noxious weed seed per pound. Seed less than 78% pure live seed will not be approved.

Tall Fescue (all approved varieties)	Bermudagrass
Kobe Lespedeza	Browntop Millet
Korean Lespedeza	German Millet – Strain R
Weeping Lovegrass	Clover – Red/White/Crimson
Carpetgrass	

Minimum 78% pure live seed; maximum 1% total weed seed; maximum 2% total other crop seed; maximum 144 restricted noxious weed seed per pound. Seed less than 76% pure live seed will not be approved.

Common or Sweet Sundangrass

Minimum 76% pure live seed; maximum 1% total weed seed; maximum 2% total other crop seed; maximum 144 restricted noxious weed seed per pound. Seed less than 74% pure live seed will not be approved.

Rye (grain; all varieties)
Kentucky Bluegrass (all approved varieties)
Hard Fescue (all approved varieties)
Shrub (bicolor) Lespedeza

Minimum 70% pure live seed; maximum 1% total weed seed; maximum 2% total other crop seed; maximum 144 noxious weed seed per pound. Seed less than 70% pure live seed will not be approved.

Centipedegrass	Japanese Millet
Crownvetch	Reed Canary Grass
Pensacola Bahiagrass	Zoysia
Creeping Red Fescue	

C204845 HI-0016, HI-0017

SSP-4

Columbus and Robeson Counties

Minimum 70% pure live seed; maximum 1% total weed seed; maximum 2% total other crop seed; maximum 5% inert matter; maximum 144 restricted noxious weed seed per pound.

Barnyard Grass
Big Bluestem
Little Bluestem
Bristly Locust
Birdsfoot Trefoil
Indiangrass
Orchardgrass
Switchgrass
Yellow Blossom Sweet Clover

STANDARD SPECIAL PROVISION**ERRATA**

(10-16-18) (Rev. 6-20-23)

Z-4

Revise the *2018 Standard Specifications* as follows:

Division 1

Page 1-1, Article 101-2 Abbreviations, line 13, replace " American National Standards Institute, Inc." with "American National Standards Institute".

Page 1-1, Article 101-2 Abbreviations, line 32, replace "Equivalent Single Axis Load" with "Equivalent Single Axle Load".

Page 1-16, Subarticle 102-9(A) General, line 26, replace "10 U.S.C. 2304(g)" with "10 U.S.C. 3205".

Page 1-43, Article 104-13 RECYCLED PRODUCTS OR SOLID WASTE MATERIALS, line 4, replace "104-13(B)(2)" with "104-13(B)".

Page 1-52, Article 106-1 RECYCLED PRODUCTS OR SOLID WASTE MATERIALS, line 25, replace "13 NCAC 7CF.0101(a)(99)" with "29 CFR 1910.1200".

Page 1-79, Article 109-1 MEASUREMENT AND PAYMENT, Test Method prior to line 34, replace "AASHTO M 32" with "AASHTO M 336".

Division 2

Page 2-5, Article 210-2 CONSTRUCTION METHODS, line 21, replace " NCGS §§ 130A-444 to -452" with "NCGS §§ 130A-444 to -453".

Page 2-13, Article 225-2 EROSION CONTROL REQUIREMENTS, line 17, replace "the Sedimentation and Pollution Control Act" with "Article 107-12".

Page 2-20, Subarticle 230-4(B)(3) Reclamation Plan, line 12, replace " Department's borrow and waste site reclamation procedures for contracted projects" with "Department's *Borrow Waste and Staging Site Reclamation Procedures for Contract Projects*".

Page 2-25, Subarticle 235-3(E) Surcharges and Waiting Periods, line 21 and 27, delete "Department's Materials and Tests Unit."

Page 2-27, Article 240-4 MEASUREMENT AND PAYMENT, line 23, replace "Section 225" with "Article 225-7".

Page 2-30, Article 275-4 MEASUREMENT AND PAYMENT, line 33, replace "Section 815" with "Article 815-4".

Division 4

Page 4-18, Subarticle 411-5(C)(3) Coring, line 11, replace "in accordance with ASTM D5079" with "with methods acceptable to the Engineer".

Page 4-50, Article 430-2 MATERIALS, prior to line 15, replace Section “1080-9” with “1080-7”.

Page 4-53, Article 440-2 MATERIALS, prior to line 6, replace Section “1080-9” with “1080-7”.

Page 4-58, Article 442-2 MATERIALS, prior to line 15, replace Section “1080-6” with “1080-12”.

Page 4-59, Subarticle 442-7(A) Blast Cleaning, line 36, replace Article “1080-6” with “1080-12”.

Page 4-76, Article 454-2 MATERIALS, prior to line 24, replace Section “815-2” with “1044”.

Page 4-79, Article 455-2 MATERIALS, prior to line 21, replace Section “815” with “1044”.

Page 4-80, Subarticle 455-3(B) Precast Gravity Wall Designs, line 23 and lines 25-26, replace “AASHTO LRFD specifications” with “*AASHTO LRFD Bridge Design Specifications*”.

Page 4-84, Article 458-5 MEASUREMENT AND PAYMENT, line 31, replace article number “454-1” with “458-1”.

Division 6

Page 6-7, Article 609-1 DESCRIPTION, line 29, replace article number “609-10” with “609-9”.

Page 6-10, Subarticle 609-6(C) Control Charts, line 17, replace Section number “7021” with “7.20.1”.

Page 6-13, Article 609-9 QUALITY ASSURANCE, line 31, replace Section number “7.60” with “7.6”.

Page 6-26, Subarticle 610-13(A)(1) Acceptance for New Construction, line 31, replace Table number “610-7” with “610-8”.

Page 6-29, Subarticle 610-13(B) North Carolina Hearne Straightedge, line 32, replace Table number “610-8” with “610-9”.

Page 6-31, Article 610-14 DENSITY ACCEPTANCE, Specified Density prior to line 30 and line 32, replace Table number “610-6” with “610-7”.

Page 6-37, Article 650-5 CONSTRUCTION METHODS, line 10, replace Section number “9.5(E)” with “9.5.1(E)”.

Page 6-44, Subarticle 660-8(B) Asphalt Mat and Seal, line 40, replace Subarticle number “660-8(A)” with “660-8(C)”.

Page 6-44, Subarticle 660-8(B) Asphalt Mat and Seal, line 42, replace Subarticle number “660-8(C)” with “660-8(A)”.

Division 7

Page 7-11, Subarticle 700-15(E) Compressive Strength, line 5, replace “AASHTO T 23” with “AASHTO R 100”.

Page 7-24, Article 723-4 Very High Early Strength Concrete for Concrete Pavement Repair, line 4, replace “AASHTO T126” with “AASHTO R 39”.

Page 7-24, Article 723-5 MEASUREMENT AND PAYMENT, line 34, replace "Section 225" with “Article 225-7”.

Page 7-24, Article 723-5 MEASUREMENT AND PAYMENT, line 36, replace "Section 270" with “Article 270-4”.

Page 7-27, Article 725-1 MEASUREMENT AND PAYMENT, line 4, replace article number “725-1” with “724-4”.

Page 7-28, Article 725-1 MEASUREMENT AND PAYMENT, line 10, replace article number “725-1” with “725-3”.

Division 8

Page 8-11, Article 815-1 MATERIALS, after line 35, replace “1080-12” with “1080-10”.

Page 8-13, Article 816-1 MATERIALS, after line 28, replace “1080-12” with “1080-10”.

Page 8-17, Article 825-1 Description, line 5, delete “853” and “855”.

Division 10

Page 10-2, Subarticle 1000-3(B) Air Entrainment, line 33, replace “Chase” with “Chace”.

Page 10-4, Subarticle 1000-4(A) Composition and Design, after line 17, replace “T23” with “R100”.

Page 10-4, Subarticle 1000-4(B) Air Entrainment, line 31 and 33, replace “Chase” with “Chace”.

Page 10-4, Subarticle 1000-4(C) Strength of Concrete, line 39 and 41, replace “T 23” with “R 100”.

Page 10-15, Subarticle 1000-11(B) Mixing Time for Central Mixed Concrete, after line 35, replace “T 23” with “R 100”.

Page 10-22, Article 1003-3 COMPOSITION AND DESIGN, line 9, replace “Engineer” with “engineer”.

Page 10-23, Article 1003-4 GROUT REQUIREMENTS, line 16 and 18, replace “T 23” with “R 100”.

Page 10-26, Article 1005-4 TESTING, after line 26, replace “1014-2€(6)” with “1014-2€(6)” in C. of Table 1005-1 footnote and replace “Lightweight^B” with “Lightweight^C”.

Page 10-29, Subarticle 1012-1(B)(4) Flat and Elongated Pieces, line 44, delete “SF9.5A”

Page 10-36, Subarticle 1012-2(E) Toughness (Resistance to Abrasion), line 31, replace “course” with “coarse”.

Page 10-37, Article 1012-4, LIGHTWEIGHT AGGREGATE, line 4, replace Table number “1012-8” with “1012-5”.

Page 10-48, Subarticle 1020-10(A) Mineral Fibers, line 27, replace “Table 1012-5” with “Table 1020-2”.

Page 10-52, Article 1024-5 FLY ASH, line 12, replace “Table 2” with “Table 3”.

Page 10-60, Subarticle 1032-6(F) Joint Materials, line 15, replace “AASHTO M 198” with “ASTM C990” and delete “Type B”.

Page 10-61, Article 1034-3 CONCRETE SEWER PIPE, line 33, replace “AASHTO M 198” with “ASTM C990” and delete “Type A or B”.

Page 10-64, Article 1040-1 BRICK, line 12, replace “ASTM C62” with “ASTM C62 or ASTM C216”.

Page 10-67, Article 1044-7 CORRUGATED PLASTIC PIPE AND FITTINGS, line 24, replace “AASHTO M 294 for heavy duty tubing” with “Article 1032-7 and AASHTO M 252”.

Page 10-68, Subarticle 1046-3(D) Offset Blocks, lines 30-32, delete “Before beginning the installation of recycled offset block, submit the FHWA acceptance letter for each type of block to the Engineer for approval.”

Page 10-69, Subarticle 1046-3(D) Offset Blocks, before line 1, replace “WIRE DIAMETER” with “COMPOSITE OFFSET BLOCKS” as the title of Table 1046-1, delete “Testing” property and associated requirement from Table 1046-1, and replace “Approval” requirement of “Approved for use by the FHWA” with “Approved for use on the NCDOT APL” in Table 1046-1.

Page 10-80, Article 1060-2 FERTILIZER, line 18, replace “North Carolina Fertilizer Law” with “North Carolina Commercial Fertilizer Law”.

Page 10-83, Article 1060-9 WATER, line 9, replace “15 NCAC 2B.0200” with “15A NCAC 02B.0200”.

Page 10-86, Article 1070-3 COLD DRAWN STEEL WIRE AND WIRE REINFORCEMENT, line 23 and 25, replace “M 32” and “M 55” with “M 336”.

Page 10-87, Article 1070-6 DOWELS AND TIE BARS FOR PORTLAND CEMENT CONCRETE PAVEMENT, line 17, replace “AASHTO M 32” with “AASHTO M 336”.

Page 10-88, Subarticle 1070-7(D) Handling, Storage and Transportation, line 40, replace “Section” with “Subarticle”.

Page 10-89, Article 1070-8 SPIRAL COLUMN REINFORCING STEEL, line 21, replace “AASHTO M 32” with “AASHTO M 336”.

Page 10-91, Article 1072-3 BEARING PLATE ASSEMBLIES, line 44, replace “Article 1080-9” with “Article 1080-7”.

Page 10-92, Subarticle 1072-5(A) General, after line 30, replace “SAMPLING REQUIREMENTS FOR HIGH STRENGTH BOLTS, NUTS AND WASHERS” with “SAMPLING REQUIREMENTS FOR HIGH STRENGTH BOLTS, NUTS AND WASHERS TO INCLUDE DIRECT TENSION INDICATORS” as the title of Table 1072-1.

Page 10-95, Subarticle 1072-5(D)(7)(a) Mill Test Report(s), line 18, replace title with “Mill Test Report(s) (MTR)”.

Page 10-95, Subarticle 1072-5(D)(7)(b) Manufacturer Certified Test Report(s), line 24, replace title with “Manufacturer Certified Test Report(s) (MCTR)”.

Page 10-96, Subarticle 1072-5(D)(7)(c) Distributor Certified Test Report(s), line 1, replace title with “Distributor Certified Test Report(s) (DCTR)”.

Page 10-98, Subarticle 1072-5(F) Galvanized High Strength Bolts, Nuts and Washers, line 11, replace “Article 1080-9” with “Article 1080-7”.

Page 10-111, Subarticle 1072-18(B) General, line 24, replace “Structural Welding Code-Reinforcing Steel” with “Structural Welding Code-Steel Reinforcing Bars”.

Page 10-117, Article 1074-1 WELDING, lines 21-22, replace “Structural Welding Code-Reinforcing Steel” with “Structural Welding Code-Steel Reinforcing Bars”.

Page 10-119, Article 1074-7(B) Gray Iron Castings, line 16, replace “M306” with “AASHTO M 306”.

Page 10-121, Article 1076-7, REPAIR OF GALVANIZING, line 8, replace article number “1080-9” with “1080-7”.

Page 10-125, Subarticle 1077-5(B) Testing, line 31, replace “T 23” with “R 100”.

Page 10-131, Subarticle 1078-4(A) Composition and Design, after line 23, in Table 1078-2 replace “T 23” with “R 100”.

Page 10-135, Subarticle 1078-4(J)(2) Mixing Time for Central Mixed Concrete, line 46, replace “Table 1078-2” with “Table 1078-3”

Page 10-136, Subarticle 1078-4(J)(2) Mixing Time for Central Mixed Concrete, after line 17, replace “T23” with “R100”.

Page 10-153, Subarticle 1079-1 PREFORMED BEARING PADS, line 8, replace “MIL-C882-D” with “MIL-C-882-E”.

Page 10-154, Subarticle 1079-2(A) General, line 6, delete “and 1079-2(E)”.

Page 10-156, Article 1080-5 SELF-CURING INORGANIC ZINC PAINT, line 8, replace “AASHTO M 252” with “AASHTO M 300”.

Page 10-156, Article 1080-5 SELF-CURING INORGANIC ZINC PAINT, line 20, replace “AASHTO M 253” with “AASHTO M 300”.

Page 10-156, Subarticle 1080-9(A) Composition, line 40, replace “Tables 1080-7 through 1080-14” with “Tables 1080-1 through 1080-3”.

Page 10-157, Subarticle 1080-9(B) Properties, line 5, replace “Tables 1080-7 through 1080-14” with “Tables 1080-1 through 1080-3”.

Page 10-157, Subarticle 1080-9(B) Properties, line 35, replace “Materials and Tests Standards CLS-P-1.0” with “*Structural Steel Shop Coatings Program*”.

Page 10-159, Subarticle 1080-9(E) Color Variation, Table 1080-1, replace “ASTM D1159” with “ASTM D1199”.

Page 10-159, Subarticle 1080-9(E) Color Variation, Table 1080-1, replace “NCDOT M&T P-10” with “ASTM D6280”.

Page 10-161, Subarticle 1080-9(E) Color Variation, Table 1080-3, replace “ASTM D13278” and “ASTM D3278”.

Page 10-161, Subarticle 1080-9(E) Color Variation, Table 1080-3, replace “NCDOT M&T P-10” and “Structural Steel Shop Coatings Program”.

Page 10-161, Subarticle 1080-9(E) Color Variation, Table 1080-3, add Test Method “ASTM D4400” for the Leneta Sag Test property in Table 1080-3.

Page 10-161, Subarticle 1080-9(E) Color Variation, Table 1080-3, add Test Method “ASTM D523” for the Gloss, Specular property in Table 1080-3.

Page 10-161, Subarticle 1080-9(E) Color Variation, Table 1080-3, replace Test Method “ASTM” with “ASTM E70” for the pH property in Table 1080-3.

Page 10-162, Article 1080-50 PAINT FOR VERTICAL MARKERS, line 1, replace article number “1080-50” with “1080-10”.

Page 10-162, Article 1080-61 EPOXY RESIN FOR REINFORCING STEEL, line 5, replace article number “1080-61” with “1080-11”.

Page 10-162, Article 1080-72 ABRASIVE MATERIALS FOR BLAST CLEANING STEEL, line 22, replace article number “1080-72” with “1080-12”.

Page 10-163, Article 1080-83 FIELD PERFORMANCE AND SERVICES, line 25, replace article number “1080-83” with “1080-13”.

Page 10-166, Subarticle 1081-1(E) Prequalification, line 24, replace “Value Management Unit” with “Product Evaluation Program”.

Page 10-168, Subarticle 1081-3(A) Physical Requirements, after line 25, replace “Subarticle 1081-4(B)” with “Subarticle 1081-3(B)” in Table 1081-2.

Page 10-168, Subarticle 1087-2(A) Paint Composition, lines 19-20, replace “Federal Specification TTP 1952F” with “Federal Specification TT-P-1952”.

Page 10-200, Subarticle 1090-1(C) Anchor Bolts, line 38, replace ASTM number “A325” with “F3125”.

Page 10-202, Subarticle 1091-3(F) Solid Wall HDPE Conduit, line 5, replace “, Table 1091-1, 1091-2 and 1091-3” with “and Table 1091-1”.

Page 10-208, Subarticle 1094-1(A) Breakaway or Simple Steel Beam Sign Supports, line 19, replace ASTM number “A325” with “F3125”.

Page 10-209, Subarticle 1094-1(D) Steel Square Tube Posts, line 10, replace ASTM number “A123” with “A653”.

Page 10-209, Subarticle 1094-1(E) Wood Supports, line 17, replace “Article 1082-2 and 1082-3” with “Section 1082”.

Page 10-212, Subarticle 1098-1(H) Electrical Service, line 21, replace “NEMA Type 3R” with “NEMA 3R”.

Page 10-212, Subarticle 1098-1(H) Electrical Service, line 36, replace “UL Standard 231” with “UL Standard UL-231”.

Page 10-212, Subarticle 1098-1(H) Electrical Service, line 37, replace “UL Standard 67” with “UL Standard UL-67”.

Page 10-224, Subarticle 1098-14(H)(1) Type I – Pedestrian Pushbutton Post, line 3, replace ASTM number “325” with “F3125”.

Page 10-224, Article 1098-16 CABINET BASE ADAPTER/EXTENDER, line 33, replace Section number “6.7” with “6.8”.

Division 14

Page 14-11, Subarticle 1401-2(B) Lowering Device, line 36, replace Military Specification “MIL-W-83420E” with “MIL-DTL-83420”.

Page 14-22, Article 1412-2 MATERIALS, line 29, replace UL Standard “1572” with “1598”.

Division 15

Page 15-6, Subarticle 1510-3(B) Testing and Sterilization, line 40, replace Section number “4.4.3” with “4.4”.

Page 15-14, Article 1525-2 MATERIALS, line 9, replace “AASHTO M 198” with “ASTM C990”.

Page 15-14, Article 1525-2 MATERIALS, lines 17-18, delete “in the Grout Production and Delivery provision”.

Page 15-19, Article 1550-2 MATERIALS, line 16, replace “*AASHTO LRFD Bridge Design Specifications*” with “*AASHTO LRFD Bridge Construction Specifications*”.

Division 16

Page 16-9, Article 1630-3 MEASUREMENT AND PAYMENT, line 7, replace "Section 225" with “Article 225-7”.

Page 16-9, Article 1630-3 MEASUREMENT AND PAYMENT, line 8, replace "Section 230" with “Article 230-5”.

Page 16-16, Article 1637-5 MEASUREMENT AND PAYMENT, line 17, replace "Section 310" with “Article 310-6”.

Division 17

Page 17-15, Article 1715-4 MEASUREMENT AND PAYMENT, lines 42-44, replace the second sentence with the following:

An example is an installation of a single 1.25 inch HDPE conduit would be paid as:

Directional Drill (1)(1.25") Linear Foot

Page 17-15, Subarticle 1715-3(E) Bore and Jack, line 5, replace article number “1540-4” with “1550-4”.

Page 17-15, Subarticle 1715-3(E) Bore and Jack, lines 10 & 11, replace "*NCDOT Policies and Procedures for Accommodating Utilities on Highway Rights of Way*” with “*NCDOT Utilities Accommodations Manual*”.

STANDARD SPECIAL PROVISION**PLANT AND PEST QUARANTINES****(Imported Fire Ant, Gypsy Moth, Witchweed, Emerald Ash Borer, Guava Root Knot Nematode, And Other Noxious Weeds)**

(3-18-03) (Rev. 5-21-19)

Z-04a

Within Quarantined Area

This project may be within a county regulated for plant and/or pests. If the project or any part of the Contractor's operations is located within a quarantined area, thoroughly clean all equipment prior to moving out of the quarantined area. Comply with federal/state regulations by obtaining a certificate or limited permit for any regulated article moving from the quarantined area.

Originating in a Quarantined County

Obtain a certificate or limited permit issued by the N.C. Department of Agriculture/United States Department of Agriculture. Have the certificate or limited permit accompany the article when it arrives at the project site.

Contact

Contact the N.C. Department of Agriculture/United States Department of Agriculture at 1-800-206-9333, 919-707-3730, or <https://www.ncagr.gov/plantindustry/Plant/quaran/table2.htm> to determine those specific project sites located in the quarantined area or for any regulated article used on this project originating in a quarantined county.

Regulated Articles Include

1. Soil, sand, gravel, compost, peat, humus, muck, and decomposed manure, separately or with other articles. This includes movement of articles listed above that may be associated with cut/waste, ditch pulling, and shoulder cutting.
2. Plants with roots including grass sod.
3. Plant crowns and roots.
4. Bulbs, corms, rhizomes, and tubers of ornamental plants.
5. Hay, straw, fodder, and plant litter of any kind.
6. Clearing and grubbing debris.
7. Used agricultural cultivating and harvesting equipment.
8. Used earth-moving equipment.
9. Any other products, articles, or means of conveyance, of any character, if determined by an inspector to present a hazard of spreading imported fire ant, gypsy moth, witchweed, emerald ash borer, guava root knot nematode, or other noxious weeds.

STANDARD SPECIAL PROVISION**TITLE VI AND NONDISCRIMINATION:**

(6-28-77)(Rev 6/19/2018)

Z-6

Revise the *2018 Standard Specifications* as follows:

Replace Article 103-4(B) with the following:

The North Carolina Department of Transportation is committed to carrying out the U.S. Department of Transportation's policy of ensuring nondiscrimination in the award and administration of contracts.

The provisions of this section related to United States Department of Transportation (US DOT) Order 1050.2A, Title 49 Code of Federal Regulations (CFR) part 21, 23 United States Code (U.S.C.) 140 and 23 CFR part 200 (or 49 CFR 303, 49 U.S.C. 5332 or 49 U.S.C. 47123) are applicable to all North Carolina Department of Transportation (NCDOT) contracts and to all related subcontracts, material supply, engineering, architectural and other service contracts, regardless of dollar amount. Any Federal provision that is specifically required not specifically set forth is hereby incorporated by reference.

(1) **Title VI Assurances (USDOT Order 1050.2A, Appendix A)**

During the performance of this contract, the contractor, for itself, its assignees, and successors in interest (hereinafter referred to as the "contractor") agrees as follows:

(a) Compliance with Regulations

The contractor (hereinafter includes consultants) shall comply with the Acts and the Regulations relative to Nondiscrimination in Federally-assisted programs of the U.S. Department of Transportation, Federal Highway Administration (FHWA), as they may be amended from time to time, which are herein incorporated by reference and made a part of this contract.

(b) Nondiscrimination

The contractor, with regard to the work performed by it during the contract, shall not discriminate on the grounds of race, color, or national origin in the selection and retention of subcontractors, including procurements of materials and leases of equipment. The contractor shall not participate directly or indirectly in the discrimination prohibited by the Acts and the Regulations, including employment practices when the contract covers any activity, project, or program set forth in Appendix B of 49 CFR Part 21.

(c) Solicitations for Subcontractors, Including Procurements of Materials and Equipment

In all solicitations, either by competitive bidding, or negotiation made by the contractor for work to be performed under a subcontract, including procurements of materials, or leases of equipment, each potential subcontractor or supplier shall be notified by the contractor of the contractor's obligations under this contract and the Acts and the Regulations relative to Nondiscrimination on the grounds of race, color, or national origin.

(d) Information and Reports

The contractor shall provide all information and reports required by the Acts, the Regulations, and directives issued pursuant thereto and shall permit access to its books, records, accounts, other sources of information, and its facilities as may be determined by the Recipient or the FHWA to be pertinent to ascertain compliance with such Acts, Regulations, and instructions. Where any information required of a contractor is in the

- exclusive possession of another who fails or refuses to furnish the information, the contractor shall so certify to the Recipient or the FHWA, as appropriate, and shall set forth what efforts it has made to obtain the information.
- (e) Sanctions for Noncompliance:
In the event of a contractor's noncompliance with the Non-discrimination provisions of this contract, the Recipient will impose such contract sanctions as it and/or the FHWA may determine to be appropriate, including, but not limited to:
- (i) Withholding payments to the contractor under the contract until the contractor complies; and/or
 - (ii) Cancelling, terminating, or suspending a contract, in whole or in part.
- (f) Incorporation of Provisions
The contractor shall include the provisions of paragraphs (a) through (f) in every subcontract, including procurements of materials and leases of equipment, unless exempt by the Acts, the Regulations and directives issued pursuant thereto. The contractor shall take action with respect to any subcontract or procurement as the Recipient or the FHWA may direct as a means of enforcing such provisions including sanctions for noncompliance. Provided, that if the contractor becomes involved in, or is threatened with litigation by a subcontractor, or supplier because of such direction, the contractor may request the Recipient to enter into any litigation to protect the interests of the Recipient. In addition, the contractor may request the United States to enter into the litigation to protect the interests of the United States.

(2) Title VI Nondiscrimination Program (23 CFR 200.5(p))

The North Carolina Department of Transportation (NCDOT) has assured the USDOT that, as a condition to receiving federal financial assistance, NCDOT will comply with Title VI of the Civil Rights Act of 1964 and all requirements imposed by Title 49 CFR part 21 and related nondiscrimination authorities to ensure that no person shall, on the ground of race, color, national origin, limited English proficiency, sex, age, or disability (including religion/creed or income-level, where applicable), be excluded from participation in, be denied the benefits of, or be subjected to discrimination under any programs, activities, or services conducted or funded by NCDOT. Contractors and other organizations under contract or agreement with NCDOT must also comply with Title VI and related authorities, therefore:

- (a) During the performance of this contract or agreement, contractors (e.g., subcontractors, consultants, vendors, prime contractors) are responsible for complying with NCDOT's Title VI Program. Contractors are not required to prepare or submit Title VI Programs. To comply with this section, the prime contractor shall:
1. Post NCDOT's Notice of Nondiscrimination and the Contractor's own Equal Employment Opportunity (EEO) Policy in conspicuous locations accessible to all employees, applicants and subcontractors on the jobsite.
 2. Physically incorporate the required Title VI clauses into all subcontracts on federally-assisted and state-funded NCDOT projects, and ensure inclusion by subcontractors into all lower-tier subcontracts.
 3. Required Solicitation Language. The Contractor shall include the following notification in all solicitations for bids and requests for work or material, regardless of funding source:
"The North Carolina Department of Transportation, in accordance with the provisions of Title VI of the Civil Rights Act of 1964 (78 Stat. 252, 42 U.S.C. §§ 2000d to 2000d-4) and the Regulations, hereby notifies all bidders that it will affirmatively ensure that any contract entered into pursuant to this advertisement, disadvantaged business enterprises will be afforded full and fair opportunity to submit bids in response to this invitation and will not

be discriminated against on the grounds of race, color, or national origin in consideration for an award. In accordance with other related nondiscrimination authorities, bidders and contractors will also not be discriminated against on the grounds of sex, age, disability, low-income level, creed/religion, or limited English proficiency in consideration for an award.”

4. Physically incorporate the FHWA-1273, in its entirety, into all subcontracts and subsequent lower tier subcontracts on Federal-aid highway construction contracts only.
 5. Provide language assistance services (i.e., written translation and oral interpretation), free of charge, to LEP employees and applicants. Contact NCDOT OCR for further assistance, if needed.
 6. For assistance with these Title VI requirements, contact the NCDOT Title VI Nondiscrimination Program at 1-800-522-0453.
- (b) Subrecipients (e.g. cities, counties, LGAs, planning organizations) may be required to prepare and submit a Title VI Plan to NCDOT, including Title VI Assurances and/or agreements. Subrecipients must also ensure compliance by their contractors and subrecipients with Title VI. (23 CFR 200.9(b)(7))
- (c) If reviewed or investigated by NCDOT, the contractor or subrecipient agrees to take affirmative action to correct any deficiencies found within a reasonable time period, not to exceed 90 calendar days, unless additional time is granted by NCDOT. (23 CFR 200.9(b)(15))
- (d) The Contractor is responsible for notifying subcontractors of NCDOT’s External Discrimination Complaints Process.
1. Applicability
Title VI and related laws protect participants and beneficiaries (e.g., members of the public and contractors) from discrimination by NCDOT employees, subrecipients and contractors, regardless of funding source.
 2. Eligibility
Any person—or class of persons—who believes he/she has been subjected to discrimination based on race, color, national origin, Limited English Proficiency (LEP), sex, age, or disability (and religion in the context of employment, aviation, or transit) may file a written complaint. The law also prohibits intimidation or retaliation of any sort.
 3. Time Limits and Filing Options
Complaints may be filed by the affected individual(s) or a representative and must be filed no later than 180 calendar days after the following:
 - (i) The date of the alleged act of discrimination; or
 - (ii) The date when the person(s) became aware of the alleged discrimination; or
 - (iii) Where there has been a continuing course of conduct, the date on which that conduct was discontinued or the latest instance of the conduct.Title VI and related discrimination complaints may be submitted to the following entities:
 - North Carolina Department of Transportation, Office of Civil Rights, Title VI Program, 1511 Mail Service Center, Raleigh, NC 27699-1511; toll free 1-800-522-0453
 - Federal Highway Administration, North Carolina Division Office, 310 New Bern Avenue, Suite 410, Raleigh, NC 27601, 919-747-7010
 - US Department of Transportation, Departmental Office of Civil Rights, External Civil Rights Programs Division, 1200 New Jersey Avenue, SE, Washington, DC 20590; 202-366-4070

4. Format for Complaints

Complaints must be in writing and signed by the complainant(s) or a representative, and include the complainant's name, address, and telephone number. Complaints received by fax or e-mail will be acknowledged and processed. Allegations received by telephone will be reduced to writing and provided to the complainant for confirmation or revision before processing. Complaints will be accepted in other languages, including Braille.

5. Discrimination Complaint Form

Contact NCDOT Civil Rights to receive a full copy of the Discrimination Complaint Form and procedures.

6. Complaint Basis

Allegations must be based on issues involving race, color, national origin (LEP), sex, age, disability, or religion (in the context of employment, aviation or transit). "Basis" refers to the complainant's membership in a protected group category.

**TABLE 103-1
COMPLAINT BASIS**

Protected Categories	Definition	Examples	Applicable Nondiscrimination Authorities
Race and Ethnicity	An individual belonging to one of the accepted racial groups; or the perception, based usually on physical characteristics that a person is a member of a racial group	Black/African American, Hispanic/Latino, Asian, American Indian/Alaska Native, Native Hawaiian/Pacific Islander, White	Title VI of the Civil Rights Act of 1964; 49 CFR Part 21; 23 CFR 200; 49 U.S.C. 5332(b); 49 U.S.C. 47123. <i>(Executive Order 13166)</i>
Color	Color of skin, including shade of skin within a racial group	Black, White, brown, yellow, etc.	
National Origin (<i>Limited English Proficiency</i>)	Place of birth. Citizenship is not a factor. (<i>Discrimination based on language or a person's accent is also covered</i>)	Mexican, Cuban, Japanese, Vietnamese, Chinese	
Sex	Gender. The sex of an individual. <i>Note: Sex under this program does not include sexual orientation.</i>	Women and Men	1973 Federal-Aid Highway Act; 49 U.S.C. 5332(b); 49 U.S.C. 47123.
Age	Persons of any age	21-year-old person	Age Discrimination Act of 1975 49 U.S.C. 5332(b); 49 U.S.C. 47123.
Disability	Physical or mental impairment, permanent or temporary, or perceived.	Blind, alcoholic, para-amputee, epileptic, diabetic, arthritic	Section 504 of the Rehabilitation Act of 1973; Americans with Disabilities Act of 1990

<p>Religion (in the context of employment) <i>(Religion/ Creed in all aspects of any aviation or transit-related construction)</i></p>	<p>An individual belonging to a religious group; or the perception, based on distinguishable characteristics that a person is a member of a religious group. In practice, actions taken as a result of the moral and ethical beliefs as to what is right and wrong, which are sincerely held with the strength of traditional religious views. Note: Does not have to be associated with a recognized religious group or church; if an individual sincerely holds to the belief, it is a protected religious practice.</p>	<p>Muslim, Christian, Sikh, Hindu, etc.</p>	<p>Title VII of the Civil Rights Act of 1964; 23 CFR 230; FHWA-1273 Required Contract Provisions. <i>(49 U.S.C. 5332(b); 49 U.S.C. 47123)</i></p>
--	---	---	---

(3) Pertinent Nondiscrimination Authorities

During the performance of this contract, the contractor, for itself, its assignees, and successors in interest agrees to comply with the following non-discrimination statutes and authorities, including, but not limited to:

- (a) Title VI of the Civil Rights Act of 1964 (42 U.S.C. § 2000d et seq., 78 stat. 252), (prohibits discrimination on the basis of race, color, national origin); and 49 CFR Part 21.
- (b) The Uniform Relocation Assistance and Real Property Acquisition Policies Act of 1970, (42 U.S.C. § 4601), (prohibits unfair treatment of persons displaced or whose property has been acquired because of Federal or Federal-aid programs and projects);
- (c) Federal-Aid Highway Act of 1973, (23 U.S.C. § 324 et seq.), (prohibits discrimination on the basis of sex);
- (d) Section 504 of the Rehabilitation Act of 1973, (29 U.S.C. § 794 et seq.), as amended, (prohibits discrimination on the basis of disability) and 49 CFR Part 27;
- (e) The Age Discrimination Act of 1975, as amended, (42 U.S.C. § 6101 et seq.), (prohibits discrimination on the basis of age);
- (f) Airport and Airway Improvement Act of 1982, (49 USC § 471, Section 47123), as amended, (prohibits discrimination based on race, creed, color, national origin, or sex);
- (g) The Civil Rights Restoration Act of 1987, (PL 100-209), (Broadened the scope, coverage and applicability of Title VI of the Civil Rights Act of 1964, The Age Discrimination Act of 1975 and Section 504 of the Rehabilitation Act of 1973, by expanding the definition of the terms "programs or activities" to include all of the programs or activities of the Federal-aid recipients, sub-recipients and contractors, whether such programs or activities are Federally funded or not);
- (h) Titles II and III of the Americans with Disabilities Act, which prohibit discrimination on the basis of disability in the operation of public entities, public and private transportation systems, places of public accommodation, and certain testing entities (42 U.S.C. §§ 12131-12189) as implemented by Department of Transportation regulations at 49 C.F.R. parts 37 and 38;
- (i) The Federal Aviation Administration's Nondiscrimination statute (49 U.S.C. § 47123) (prohibits discrimination on the basis of race, color, national origin, and sex);
- (j) Executive Order 12898, Federal Actions to Address Environmental Justice in Minority Populations and Low-Income Populations, which ensures Nondiscrimination against minority populations by discouraging programs, policies, and activities with disproportionately high and adverse human health or environmental effects on minority and low-income populations;

- (k) Executive Order 13166, Improving Access to Services for Persons with Limited English Proficiency, and resulting agency guidance, national origin discrimination includes discrimination because of Limited English proficiency (LEP). To ensure compliance with Title VI, you must take reasonable steps to ensure that LEP persons have meaningful access to your programs (70 Fed. Reg. at 74087 to 74100);
 - (l) Title IX of the Education Amendments of 1972, as amended, which prohibits you from discriminating because of sex in education programs or activities (20 U.S.C. 1681 et seq).
 - (m) Title VII of the Civil Rights Act of 1964 (42 U.S.C. § 2000e et seq., Pub. L. 88-352), (prohibits employment discrimination on the basis of race, color, religion, sex, or national origin).
- (4) **Additional Title VI Assurances**
- **The following Title VI Assurances (Appendices B, C and D) shall apply, as applicable*
- (a) Clauses for Deeds Transferring United States Property (1050.2A, Appendix B)
The following clauses will be included in deeds effecting or recording the transfer of real property, structures, or improvements thereon, or granting interest therein from the United States pursuant to the provisions of Assurance 4.

NOW, THEREFORE, the U.S. Department of Transportation as authorized by law and upon the condition that the North Carolina Department of Transportation (NCDOT) will accept title to the lands and maintain the project constructed thereon in accordance with the North Carolina General Assembly, the Regulations for the Administration of the Federal-Aid Highway Program, and the policies and procedures prescribed by the Federal Highway Administration of the U.S. Department of Transportation in accordance and in compliance with all requirements imposed by Title 49, Code of Federal Regulations, U.S. Department of Transportation, Subtitle A, Office of the Secretary, Part 21, Nondiscrimination in Federally-assisted programs of the U.S. Department of Transportation pertaining to and effectuating the provisions of Title VI of the Civil Rights Act of 1964 (78 Stat. 252; 42 U.S.C. § 2000d to 2000d-4), does hereby remise, release, quitclaim and convey unto the NCDOT all the right, title and interest of the U.S. Department of Transportation in and to said lands described in Exhibit A attached hereto and made a part hereof.

(HABENDUM CLAUSE)

TO HAVE AND TO HOLD said lands and interests therein unto the North Carolina Department of Transportation (NCDOT) and its successors forever, subject, however, to the covenants, conditions, restrictions and reservations herein contained as follows, which will remain in effect for the period during which the real property or structures are used for a purpose for which Federal financial assistance is extended or for another purpose involving the provision of similar services or benefits and will be binding on the NCDOT, its successors and assigns.

The NCDOT, in consideration of the conveyance of said lands and interests in lands, does hereby covenant and agree as a covenant running with the land for itself, its successors and assigns, that (1) no person will on the grounds of race, color, or national origin, be excluded from participation in, be denied the benefits of, or be otherwise subjected to discrimination with regard to any facility located wholly or in part on, over, or under such lands hereby conveyed [,] [and]* (2) that the NCDOT will use the lands and interests in lands and interests in lands so conveyed, in compliance with all requirements imposed by or pursuant to Title 49, Code of Federal Regulations, U.S. Department of Transportation, Subtitle A, Office of the Secretary, Part 21, Non-discrimination in Federally-assisted programs of the U.S. Department of Transportation, Effectuation of Title VI of the Civil Rights Act of 1964, and as said Regulations and Acts may be amended [,] and (3) that in the event of breach of any of the above-mentioned nondiscrimination conditions, the Department will have a right to enter or re-enter said lands and facilities on said land, and that above described land and facilities will thereon revert to and vest in and become the absolute property of the U.S. Department of Transportation and its assigns as such interest existed prior to this instruction].*

(*Reverter clause and related language to be used only when it is determined that such a clause is necessary in order to make clear the purpose of Title VI.)

(b) Clauses for Transfer of Real Property Acquired or Improved Under the Activity, Facility, or Program (1050.2A, Appendix C)

The following clauses will be included in deeds, licenses, leases, permits, or similar instruments entered into by the North Carolina Department of Transportation (NCDOT) pursuant to the provisions of Assurance 7(a):

1. The (grantee, lessee, permittee, etc. as appropriate) for himself/herself, his/her heirs, personal representatives, successors in interest, and assigns, as a part of the consideration hereof, does hereby covenant and agree [in the case of deeds and leases add "as a covenant running with the land"] that:
 - (i.) In the event facilities are constructed, maintained, or otherwise operated on the property described in this (deed, license, lease, permit, etc.) for a purpose for which a U.S. Department of Transportation activity, facility, or program is extended or for another purpose involving the provision of similar services or benefits, the (grantee, licensee, lessee, permittee, etc.) will maintain and operate such facilities and services in compliance with all requirements imposed by the Acts and Regulations (as may be amended) such that no person on the grounds of race, color, or national origin, will be excluded from participation in, denied the benefits of, or be otherwise subjected to discrimination in the use of said facilities.
2. With respect to licenses, leases, permits, etc., in the event of breach of any of the above Nondiscrimination covenants, the NCDOT will have the right to terminate the (lease, license, permit, etc.) and to enter, re-enter, and repossess said lands and facilities thereon, and hold the same as if the (lease, license, permit, etc.) had never been made or issued. *
3. With respect to a deed, in the event of breach of any of the above Nondiscrimination covenants, the NCDOT will have the right to enter or re-enter the lands and facilities thereon, and the above described lands and facilities will there upon revert to and vest in and become the absolute property of the NCDOT and its assigns. *

(*Reverter clause and related language to be used only when it is determined that such a clause is necessary to make clear the purpose of Title VI.)

(c) Clauses for Construction/Use/Access to Real Property Acquired Under the Activity, Facility or Program (1050.2A, Appendix D)

The following clauses will be included in deeds, licenses, permits, or similar instruments/ agreements entered into by the North Carolina Department of Transportation (NCDOT) pursuant to the provisions of Assurance 7(b):

1. The (grantee, licensee, permittee, etc., as appropriate) for himself/herself, his/her heirs, personal representatives, successors in interest, and assigns, as a part of the consideration hereof, does hereby covenant and agree (in the case of deeds and leases add, "as a covenant running with the land") that (1) no person on the ground of race, color, or national origin, will be excluded from participation in, denied the benefits of, or be otherwise subjected to discrimination in the use of said facilities, (2) that in the construction of any improvements on, over, or under such land, and the furnishing of services thereon, no person on the ground of race, color, or national origin, will be excluded from participation in, denied the benefits of, or otherwise be subjected to discrimination, (3) that the (grantee, licensee, lessee, permittee, etc.) will use the premises in compliance with all other requirements imposed by or pursuant to the Acts and Regulations, as amended, set forth in this Assurance.
2. With respect to (licenses, leases, permits, etc.), in the event of breach of any of the above Non-discrimination covenants, the NCDOT will have the right to terminate the (license, permit, etc., as appropriate) and to enter or re-enter and repossess said land and the facilities thereon, and hold the same as if said (license, permit, etc., as appropriate) had never been made or issued. *
3. With respect to deeds, in the event of breach of any of the above Nondiscrimination covenants, the NCDOT will there upon revert to and vest in and become the absolute property of the NCDOT and its assigns. *

(*Reverter clause and related language to be used only when it is determined that such a clause is necessary to make clear the purpose of Title VI.)

STANDARD SPECIAL PROVISION**MINORITY AND FEMALE EMPLOYMENT REQUIREMENTS**

Z-7

NOTICE OF REQUIREMENTS FOR AFFIRMATIVE ACTION TO ENSURE EQUAL EMPLOYMENT OPPORTUNITY (*EXECUTIVE NUMBER 11246*)

1. The goals and timetables for minority and female participation, expressed in percentage terms for the Contractor's aggregate workforce in each trade on all construction work in the covered area, see as shown on the attached sheet entitled "Employment Goals for Minority and Female participation".

These goals are applicable to all the Contractor's construction work (whether or not it is Federal or federally assisted) performed in the covered area. If the Contractor performs construction work in a geographical area located outside of the covered area, it shall apply the goals established for such geographical area where the work is actually performed. With regard to this second area, the Contractor also is subject to the goals for both its federally involved and nonfederally involved construction.

The Contractor's compliance with the Executive Order and the regulations in *41 CFR Part 60-4* shall be based on its implementation of the Equal Opportunity Clause, specific affirmative action obligations required by the specifications set forth in *41 CFR 60-4.3(a)*, and its effort to meet the goals. The hours of minority and female employment and training must be substantially uniform throughout the length of the contract, and in each trade and the Contractor shall make a good faith effort to employ minorities and women evenly on each of its projects. The transfer of minority or female employees or trainees from Contractor to Contractor or from project to project for the sole purpose of meeting the Contractor's goals shall be a violation of the contract, the executive Order and the regulations in *41 CFR Part 60-4*. Compliance with the goals will be measured against the total work hours performed.

2. As used in this Notice and in the contract resulting from this solicitation, the "covered area" is the county or counties shown on the cover sheet of the proposal form and contract.

**EMPLOYMENT GOALS FOR MINORITY
AND FEMALE PARTICIPATION**

Economic Areas

Area 023 29.7%

Bertie County
Camden County
Chowan County
Gates County
Hertford County
Pasquotank County
Perquimans County

Area 024 31.7%

Beaufort County
Carteret County
Craven County
Dare County
Edgecombe County
Green County
Halifax County
Hyde County
Jones County
Lenoir County
Martin County
Nash County
Northampton County
Pamlico County
Pitt County
Tyrrell County
Washington County
Wayne County
Wilson County

Area 025 23.5%

Columbus County
Duplin County
Onslow County
Pender County

Area 026 33.5%

Bladen County
Hoke County
Richmond County
Robeson County
Sampson County
Scotland County

Area 027 24.7%

Chatham County
Franklin County
Granville County
Harnett County
Johnston County
Lee County
Person County
Vance County
Warren County

Area 028 15.5%

Alleghany County
Ashe County
Caswell County
Davie County
Montgomery County
Moore County
Rockingham County
Surry County
Watauga County
Wilkes County

Area 029 15.7%

Alexander County
Anson County
Burke County
Cabarrus County
Caldwell County
Catawba County
Cleveland County
Iredell County
Lincoln County
Polk County
Rowan County
Rutherford County
Stanly County

Area 0480 8.5%

Buncombe County
Madison County

Area 030 6.3%

Avery County
Cherokee County
Clay County
Graham County
Haywood County
Henderson County
Jackson County
McDowell County
Macon County
Mitchell County
Swain County
Transylvania County
Yancey County

SMSA Areas

Area 5720 26.6%
Currituck County

Area 9200 20.7%
Brunswick County
New Hanover County

Area 2560 24.2%
Cumberland County

Area 6640 22.8%
Durham County
Orange County
Wake County

Area 1300 16.2%
Alamance County

Area 3120 16.4%
Davidson County
Forsyth County
Guilford County
Randolph County
Stokes County
Yadkin County

Area 1520 18.3%
Gaston County
Mecklenburg County
Union County

Goals for Female

Participation in Each Trade

(Statewide) 6.9%

FHWA-1273 -- Revised October 23, 2023

REQUIRED CONTRACT PROVISIONS FEDERAL-AID CONSTRUCTION CONTRACTS

- I. General
- II. Nondiscrimination
- III. Non-segregated Facilities
- IV. Davis-Bacon and Related Act Provisions
- V. Contract Work Hours and Safety Standards Act Provisions
- VI. Subletting or Assigning the Contract
- VII. Safety: Accident Prevention
- VIII. False Statements Concerning Highway Projects
- IX. Implementation of Clean Air Act and Federal Water Pollution Control Act
- X. Certification Regarding Debarment, Suspension, Ineligibility and Voluntary Exclusion
- XI. Certification Regarding Use of Contract Funds for Lobbying
- XII. Use of United States-Flag Vessels:

ATTACHMENTS

A. Employment and Materials Preference for Appalachian Development Highway System or Appalachian Local Access Road Contracts (included in Appalachian contracts only)

I. GENERAL

1. Form FHWA-1273 must be physically incorporated in each construction contract funded under title 23, United States Code, as required in 23 CFR 633.102(b) (excluding emergency contracts solely intended for debris removal). The contractor (or subcontractor) must insert this form in each subcontract and further require its inclusion in all lower tier subcontracts (excluding purchase orders, rental agreements and other agreements for supplies or services). 23 CFR 633.102(e).

The applicable requirements of Form FHWA-1273 are incorporated by reference for work done under any purchase order, rental agreement or agreement for other services. The prime contractor shall be responsible for compliance by any subcontractor, lower-tier subcontractor or service provider. 23 CFR 633.102(e).

Form FHWA-1273 must be included in all Federal-aid design-build contracts, in all subcontracts and in lower tier subcontracts (excluding subcontracts for design services, purchase orders, rental agreements and other agreements for supplies or services) in accordance with 23 CFR 633.102. The design-builder shall be responsible for compliance by any subcontractor, lower-tier subcontractor or service provider.

Contracting agencies may reference Form FHWA-1273 in solicitation-for-bids or request-for-proposals documents, however, the Form FHWA-1273 must be physically incorporated (not referenced) in all contracts, subcontracts and lower-tier subcontracts (excluding purchase orders, rental agreements and other agreements for supplies or services related to a construction contract). 23 CFR 633.102(b).

2. Subject to the applicability criteria noted in the following sections, these contract provisions shall apply to all work

performed on the contract by the contractor's own organization and with the assistance of workers under the contractor's immediate superintendence and to all work performed on the contract by piecework, station work, or by subcontract. 23 CFR 633.102(d).

3. A breach of any of the stipulations contained in these Required Contract Provisions may be sufficient grounds for withholding of progress payments, withholding of final payment, termination of the contract, suspension / debarment or any other action determined to be appropriate by the contracting agency and FHWA.

4. Selection of Labor: During the performance of this contract, the contractor shall not use convict labor for any purpose within the limits of a construction project on a Federal-aid highway unless it is labor performed by convicts who are on parole, supervised release, or probation. 23 U.S.C. 114(b). The term Federal-aid highway does not include roadways functionally classified as local roads or rural minor collectors. 23 U.S.C. 101(a).

II. NONDISCRIMINATION (23 CFR 230.107(a); 23 CFR Part 230, Subpart A, Appendix A; EO 11246)

The provisions of this section related to 23 CFR Part 230, Subpart A, Appendix A are applicable to all Federal-aid construction contracts and to all related construction subcontracts of \$10,000 or more. The provisions of 23 CFR Part 230 are not applicable to material supply, engineering, or architectural service contracts.

In addition, the contractor and all subcontractors must comply with the following policies: Executive Order 11246, 41 CFR Part 60, 29 CFR Parts 1625-1627, 23 U.S.C. 140, Section 504 of the Rehabilitation Act of 1973, as amended (29 U.S.C. 794), Title VI of the Civil Rights Act of 1964, as amended (42 U.S.C. 2000d et seq.), and related regulations including 49 CFR Parts 21, 26, and 27; and 23 CFR Parts 200, 230, and 633.

The contractor and all subcontractors must comply with: the requirements of the Equal Opportunity Clause in 41 CFR 60-1.4(b) and, for all construction contracts exceeding \$10,000, the Standard Federal Equal Employment Opportunity Construction Contract Specifications in 41 CFR 60-4.3.

Note: The U.S. Department of Labor has exclusive authority to determine compliance with Executive Order 11246 and the policies of the Secretary of Labor including 41 CFR Part 60, and 29 CFR Parts 1625-1627. The contracting agency and the FHWA have the authority and the responsibility to ensure compliance with 23 U.S.C. 140, Section 504 of the Rehabilitation Act of 1973, as amended (29 U.S.C. 794), and Title VI of the Civil Rights Act of 1964, as amended (42 U.S.C. 2000d et seq.), and related regulations including 49 CFR Parts 21, 26, and 27; and 23 CFR Parts 200, 230, and 633.

The following provision is adopted from 23 CFR Part 230, Subpart A, Appendix A, with appropriate revisions to conform to the U.S. Department of Labor (US DOL) and FHWA requirements.

1. Equal Employment Opportunity: Equal Employment Opportunity (EEO) requirements not to discriminate and to take affirmative action to assure equal opportunity as set forth under laws, executive orders, rules, regulations (*see* 28 CFR Part 35, 29 CFR Part 1630, 29 CFR Parts 1625-1627, 41 CFR Part 60 and 49 CFR Part 27) and orders of the Secretary of Labor as modified by the provisions prescribed herein, and imposed pursuant to 23 U.S.C. 140, shall constitute the EEO and specific affirmative action standards for the contractor's project activities under this contract. The provisions of the Americans with Disabilities Act of 1990 (42 U.S.C. 12101 et seq.) set forth under 28 CFR Part 35 and 29 CFR Part 1630 are incorporated by reference in this contract. In the execution of this contract, the contractor agrees to comply with the following minimum specific requirement activities of EEO:

a. The contractor will work with the contracting agency and the Federal Government to ensure that it has made every good faith effort to provide equal opportunity with respect to all of its terms and conditions of employment and in their review of activities under the contract. 23 CFR 230.409 (g)(4) & (5).

b. The contractor will accept as its operating policy the following statement:

"It is the policy of this Company to assure that applicants are employed, and that employees are treated during employment, without regard to their race, religion, sex, sexual orientation, gender identity, color, national origin, age or disability. Such action shall include: employment, upgrading, demotion, or transfer; recruitment or recruitment advertising; layoff or termination; rates of pay or other forms of compensation; and selection for training, including apprenticeship, pre-apprenticeship, and/or on-the-job training."

2. EEO Officer: The contractor will designate and make known to the contracting officers an EEO Officer who will have the responsibility for and must be capable of effectively administering and promoting an active EEO program and who must be assigned adequate authority and responsibility to do so.

3. Dissemination of Policy: All members of the contractor's staff who are authorized to hire, supervise, promote, and discharge employees, or who recommend such action or are substantially involved in such action, will be made fully cognizant of and will implement the contractor's EEO policy and contractual responsibilities to provide EEO in each grade and classification of employment. To ensure that the above agreement will be met, the following actions will be taken as a minimum:

a. Periodic meetings of supervisory and personnel office employees will be conducted before the start of work and then not less often than once every six months, at which time the contractor's EEO policy and its implementation will be reviewed and explained. The meetings will be conducted by the EEO Officer or other knowledgeable company official.

b. All new supervisory or personnel office employees will be given a thorough indoctrination by the EEO Officer, covering all major aspects of the contractor's EEO obligations within thirty days following their reporting for duty with the contractor.

c. All personnel who are engaged in direct recruitment for the project will be instructed by the EEO Officer in the contractor's procedures for locating and hiring minorities and women.

d. Notices and posters setting forth the contractor's EEO policy will be placed in areas readily accessible to employees, applicants for employment and potential employees.

e. The contractor's EEO policy and the procedures to implement such policy will be brought to the attention of employees by means of meetings, employee handbooks, or other appropriate means.

4. Recruitment: When advertising for employees, the contractor will include in all advertisements for employees the notation: "An Equal Opportunity Employer." All such advertisements will be placed in publications having a large circulation among minorities and women in the area from which the project work force would normally be derived.

a. The contractor will, unless precluded by a valid bargaining agreement, conduct systematic and direct recruitment through public and private employee referral sources likely to yield qualified minorities and women. To meet this requirement, the contractor will identify sources of potential minority group employees and establish with such identified sources procedures whereby minority and women applicants may be referred to the contractor for employment consideration.

b. In the event the contractor has a valid bargaining agreement providing for exclusive hiring hall referrals, the contractor is expected to observe the provisions of that agreement to the extent that the system meets the contractor's compliance with EEO contract provisions. Where implementation of such an agreement has the effect of discriminating against minorities or women, or obligates the contractor to do the same, such implementation violates Federal nondiscrimination provisions.

c. The contractor will encourage its present employees to refer minorities and women as applicants for employment. Information and procedures with regard to referring such applicants will be discussed with employees.

5. Personnel Actions: Wages, working conditions, and employee benefits shall be established and administered, and personnel actions of every type, including hiring, upgrading, promotion, transfer, demotion, layoff, and termination, shall be taken without regard to race, color, religion, sex, sexual orientation, gender identity, national origin, age or disability. The following procedures shall be followed:

a. The contractor will conduct periodic inspections of project sites to ensure that working conditions and employee facilities do not indicate discriminatory treatment of project site personnel.

b. The contractor will periodically evaluate the spread of wages paid within each classification to determine any evidence of discriminatory wage practices.

c. The contractor will periodically review selected personnel actions in depth to determine whether there is evidence of discrimination. Where evidence is found, the contractor will promptly take corrective action. If the review indicates that the discrimination may extend beyond the actions reviewed, such corrective action shall include all affected persons.

d. The contractor will promptly investigate all complaints of alleged discrimination made to the contractor in connection with its obligations under this contract, will attempt to resolve such complaints, and will take appropriate corrective action

within a reasonable time. If the investigation indicates that the discrimination may affect persons other than the complainant, such corrective action shall include such other persons. Upon completion of each investigation, the contractor will inform every complainant of all of their avenues of appeal.

6. Training and Promotion:

a. The contractor will assist in locating, qualifying, and increasing the skills of minorities and women who are applicants for employment or current employees. Such efforts should be aimed at developing full journey level status employees in the type of trade or job classification involved.

b. Consistent with the contractor's work force requirements and as permissible under Federal and State regulations, the contractor shall make full use of training programs (i.e., apprenticeship and on-the-job training programs for the geographical area of contract performance). In the event a special provision for training is provided under this contract, this subparagraph will be superseded as indicated in the special provision. The contracting agency may reserve training positions for persons who receive welfare assistance in accordance with 23 U.S.C. 140(a).

c. The contractor will advise employees and applicants for employment of available training programs and entrance requirements for each.

d. The contractor will periodically review the training and promotion potential of employees who are minorities and women and will encourage eligible employees to apply for such training and promotion.

7. Unions: If the contractor relies in whole or in part upon unions as a source of employees, the contractor will use good faith efforts to obtain the cooperation of such unions to increase opportunities for minorities and women. 23 CFR 230.409. Actions by the contractor, either directly or through contractor's association acting as agent, will include the procedures set forth below:

a. The contractor will use good faith efforts to develop, in cooperation with the unions, joint training programs aimed toward qualifying more minorities and women for membership in the unions and increasing the skills of minorities and women so that they may qualify for higher paying employment.

b. The contractor will use good faith efforts to incorporate an EEO clause into each union agreement to the end that such union will be contractually bound to refer applicants without regard to their race, color, religion, sex, sexual orientation, gender identity, national origin, age, or disability.

c. The contractor is to obtain information as to the referral practices and policies of the labor union except that to the extent such information is within the exclusive possession of the labor union and such labor union refuses to furnish such information to the contractor, the contractor shall so certify to the contracting agency and shall set forth what efforts have been made to obtain such information.

d. In the event the union is unable to provide the contractor with a reasonable flow of referrals within the time limit set forth in the collective bargaining agreement, the contractor will, through independent recruitment efforts, fill the employment vacancies without regard to race, color, religion, sex, sexual orientation, gender identity, national origin, age, or disability; making full efforts to obtain qualified and/or qualifiable minorities and women. The failure of a union to provide

sufficient referrals (even though it is obligated to provide exclusive referrals under the terms of a collective bargaining agreement) does not relieve the contractor from the requirements of this paragraph. In the event the union referral practice prevents the contractor from meeting the obligations pursuant to Executive Order 11246, as amended, and these special provisions, such contractor shall immediately notify the contracting agency.

8. Reasonable Accommodation for Applicants / Employees with Disabilities: The contractor must be familiar with the requirements for and comply with the Americans with Disabilities Act and all rules and regulations established thereunder. Employers must provide reasonable accommodation in all employment activities unless to do so would cause an undue hardship.

9. Selection of Subcontractors, Procurement of Materials and Leasing of Equipment: The contractor shall not discriminate on the grounds of race, color, religion, sex, sexual orientation, gender identity, national origin, age, or disability in the selection and retention of subcontractors, including procurement of materials and leases of equipment. The contractor shall take all necessary and reasonable steps to ensure nondiscrimination in the administration of this contract.

a. The contractor shall notify all potential subcontractors, suppliers, and lessors of their EEO obligations under this contract.

b. The contractor will use good faith efforts to ensure subcontractor compliance with their EEO obligations.

10. Assurances Required:

a. The requirements of 49 CFR Part 26 and the State DOT's FHWA-approved Disadvantaged Business Enterprise (DBE) program are incorporated by reference.

b. The contractor, subrecipient or subcontractor shall not discriminate on the basis of race, color, national origin, or sex in the performance of this contract. The contractor shall carry out applicable requirements of 49 CFR part 26 in the award and administration of DOT-assisted contracts. Failure by the contractor to carry out these requirements is a material breach of this contract, which may result in the termination of this contract or such other remedy as the recipient deems appropriate, which may include, but is not limited to:

- (1) Withholding monthly progress payments;
- (2) Assessing sanctions;
- (3) Liquidated damages; and/or
- (4) Disqualifying the contractor from future bidding as non-responsible.

c. The Title VI and nondiscrimination provisions of U.S. DOT Order 1050.2A at Appendixes A and E are incorporated by reference. 49 CFR Part 21.

11. Records and Reports: The contractor shall keep such records as necessary to document compliance with the EEO requirements. Such records shall be retained for a period of three years following the date of the final payment to the contractor for all contract work and shall be available at reasonable times and places for inspection by authorized representatives of the contracting agency and the FHWA.

a. The records kept by the contractor shall document the following:

(1) The number and work hours of minority and non-minority group members and women employed in each work classification on the project;

(2) The progress and efforts being made in cooperation with unions, when applicable, to increase employment opportunities for minorities and women; and

(3) The progress and efforts being made in locating, hiring, training, qualifying, and upgrading minorities and women.

b. The contractors and subcontractors will submit an annual report to the contracting agency each July for the duration of the project indicating the number of minority, women, and non-minority group employees currently engaged in each work classification required by the contract work. This information is to be reported on Form FHWA-1391. The staffing data should represent the project work force on board in all or any part of the last payroll period preceding the end of July. If on-the-job training is being required by special provision, the contractor will be required to collect and report training data. The employment data should reflect the work force on board during all or any part of the last payroll period preceding the end of July.

III. NONSEGREGATED FACILITIES

This provision is applicable to all Federal-aid construction contracts and to all related construction subcontracts of more than \$10,000. 41 CFR 60-1.5.

As prescribed by 41 CFR 60-1.8, the contractor must ensure that facilities provided for employees are provided in such a manner that segregation on the basis of race, color, religion, sex, sexual orientation, gender identity, or national origin cannot result. The contractor may neither require such segregated use by written or oral policies nor tolerate such use by employee custom. The contractor's obligation extends further to ensure that its employees are not assigned to perform their services at any location under the contractor's control where the facilities are segregated. The term "facilities" includes waiting rooms, work areas, restaurants and other eating areas, time clocks, restrooms, washrooms, locker rooms and other storage or dressing areas, parking lots, drinking fountains, recreation or entertainment areas, transportation, and housing provided for employees. The contractor shall provide separate or single-user restrooms and necessary dressing or sleeping areas to assure privacy between sexes.

IV. DAVIS-BACON AND RELATED ACT PROVISIONS

This section is applicable to all Federal-aid construction projects exceeding \$2,000 and to all related subcontracts and lower-tier subcontracts (regardless of subcontract size), in accordance with 29 CFR 5.5. The requirements apply to all projects located within the right-of-way of a roadway that is functionally classified as Federal-aid highway. 23 U.S.C. 113. This excludes roadways functionally classified as local roads or rural minor collectors, which are exempt. 23 U.S.C. 101. Where applicable law requires that projects be treated as a project on a Federal-aid highway, the provisions of this subpart will apply regardless of the location of the project. Examples include: Surface Transportation Block Grant Program projects funded under 23 U.S.C. 133 [excluding recreational trails projects], the Nationally Significant Freight and Highway

Projects funded under 23 U.S.C. 117, and National Highway Freight Program projects funded under 23 U.S.C. 167.

The following provisions are from the U.S. Department of Labor regulations in 29 CFR 5.5 "Contract provisions and related matters" with minor revisions to conform to the FHWA-1273 format and FHWA program requirements.

1. Minimum wages (29 CFR 5.5)

a. *Wage rates and fringe benefits.* All laborers and mechanics employed or working upon the site of the work (or otherwise working in construction or development of the project under a development statute), will be paid unconditionally and not less often than once a week, and without subsequent deduction or rebate on any account (except such payroll deductions as are permitted by regulations issued by the Secretary of Labor under the Copeland Act (29 CFR part 3)), the full amount of basic hourly wages and bona fide fringe benefits (or cash equivalents thereof) due at time of payment computed at rates not less than those contained in the wage determination of the Secretary of Labor which is attached hereto and made a part hereof, regardless of any contractual relationship which may be alleged to exist between the contractor and such laborers and mechanics. As provided in paragraphs (d) and (e) of 29 CFR 5.5, the appropriate wage determinations are effective by operation of law even if they have not been attached to the contract. Contributions made or costs reasonably anticipated for bona fide fringe benefits under the Davis-Bacon Act (40 U.S.C. 3141(2)(B)) on behalf of laborers or mechanics are considered wages paid to such laborers or mechanics, subject to the provisions of paragraph 1.e. of this section; also, regular contributions made or costs incurred for more than a weekly period (but not less often than quarterly) under plans, funds, or programs which cover the particular weekly period, are deemed to be constructively made or incurred during such weekly period. Such laborers and mechanics must be paid the appropriate wage rate and fringe benefits on the wage determination for the classification(s) of work actually performed, without regard to skill, except as provided in paragraph 4. of this section. Laborers or mechanics performing work in more than one classification may be compensated at the rate specified for each classification for the time actually worked therein: *Provided*, That the employer's payroll records accurately set forth the time spent in each classification in which work is performed. The wage determination (including any additional classifications and wage rates conformed under paragraph 1.c. of this section) and the Davis-Bacon poster (WH-1321) must be posted at all times by the contractor and its subcontractors at the site of the work in a prominent and accessible place where it can be easily seen by the workers.

b. *Frequently recurring classifications.* (1) In addition to wage and fringe benefit rates that have been determined to be prevailing under the procedures set forth in 29 CFR part 1, a wage determination may contain, pursuant to § 1.3(f), wage and fringe benefit rates for classifications of laborers and mechanics for which conformance requests are regularly submitted pursuant to paragraph 1.c. of this section, provided that:

(i) The work performed by the classification is not performed by a classification in the wage determination for which a prevailing wage rate has been determined;

(ii) The classification is used in the area by the construction industry; and

(iii) The wage rate for the classification bears a reasonable relationship to the prevailing wage rates contained in the wage determination.

(2) The Administrator will establish wage rates for such classifications in accordance with paragraph 1.c.(1)(iii) of this section. Work performed in such a classification must be paid at no less than the wage and fringe benefit rate listed on the wage determination for such classification.

c. *Conformance.* (1) The contracting officer must require that any class of laborers or mechanics, including helpers, which is not listed in the wage determination and which is to be employed under the contract be classified in conformance with the wage determination. Conformance of an additional classification and wage rate and fringe benefits is appropriate only when the following criteria have been met:

(i) The work to be performed by the classification requested is not performed by a classification in the wage determination; and

(ii) The classification is used in the area by the construction industry; and

(iii) The proposed wage rate, including any bona fide fringe benefits, bears a reasonable relationship to the wage rates contained in the wage determination.

(2) The conformance process may not be used to split, subdivide, or otherwise avoid application of classifications listed in the wage determination.

(3) If the contractor and the laborers and mechanics to be employed in the classification (if known), or their representatives, and the contracting officer agree on the classification and wage rate (including the amount designated for fringe benefits where appropriate), a report of the action taken will be sent by the contracting officer by email to DBAconformance@dol.gov. The Administrator, or an authorized representative, will approve, modify, or disapprove every additional classification action within 30 days of receipt and so advise the contracting officer or will notify the contracting officer within the 30-day period that additional time is necessary.

(4) In the event the contractor, the laborers or mechanics to be employed in the classification or their representatives, and the contracting officer do not agree on the proposed classification and wage rate (including the amount designated for fringe benefits, where appropriate), the contracting officer will, by email to DBAconformance@dol.gov, refer the questions, including the views of all interested parties and the recommendation of the contracting officer, to the Administrator for determination. The Administrator, or an authorized representative, will issue a determination within 30 days of receipt and so advise the contracting officer or will notify the contracting officer within the 30-day period that additional time is necessary.

(5) The contracting officer must promptly notify the contractor of the action taken by the Wage and Hour Division

under paragraphs 1.c.(3) and (4) of this section. The contractor must furnish a written copy of such determination to each affected worker or it must be posted as a part of the wage determination. The wage rate (including fringe benefits where appropriate) determined pursuant to paragraph 1.c.(3) or (4) of this section must be paid to all workers performing work in the classification under this contract from the first day on which work is performed in the classification.

d. *Fringe benefits not expressed as an hourly rate.*

Whenever the minimum wage rate prescribed in the contract for a class of laborers or mechanics includes a fringe benefit which is not expressed as an hourly rate, the contractor may either pay the benefit as stated in the wage determination or may pay another bona fide fringe benefit or an hourly cash equivalent thereof.

e. *Unfunded plans.* If the contractor does not make payments to a trustee or other third person, the contractor may consider as part of the wages of any laborer or mechanic the amount of any costs reasonably anticipated in providing bona fide fringe benefits under a plan or program, *Provided*, That the Secretary of Labor has found, upon the written request of the contractor, in accordance with the criteria set forth in § 5.28, that the applicable standards of the Davis-Bacon Act have been met. The Secretary of Labor may require the contractor to set aside in a separate account assets for the meeting of obligations under the plan or program.

f. *Interest.* In the event of a failure to pay all or part of the wages required by the contract, the contractor will be required to pay interest on any underpayment of wages.

2. Withholding (29 CFR 5.5)

a. *Withholding requirements.* The contracting agency may, upon its own action, or must, upon written request of an authorized representative of the Department of Labor, withhold or cause to be withheld from the contractor so much of the accrued payments or advances as may be considered necessary to satisfy the liabilities of the prime contractor or any subcontractor for the full amount of wages and monetary relief, including interest, required by the clauses set forth in this section for violations of this contract, or to satisfy any such liabilities required by any other Federal contract, or federally assisted contract subject to Davis-Bacon labor standards, that is held by the same prime contractor (as defined in § 5.2). The necessary funds may be withheld from the contractor under this contract, any other Federal contract with the same prime contractor, or any other federally assisted contract that is subject to Davis-Bacon labor standards requirements and is held by the same prime contractor, regardless of whether the other contract was awarded or assisted by the same agency, and such funds may be used to satisfy the contractor liability for which the funds were withheld. In the event of a contractor's failure to pay any laborer or mechanic, including any apprentice or helper working on the site of the work all or part of the wages required by the contract, or upon the contractor's failure to submit the required records as discussed in paragraph 3.d. of this section, the contracting agency may on its own initiative and after written notice to the contractor, take such action as may be necessary to cause the suspension of any further payment, advance, or guarantee of funds until such violations have ceased.

b. *Priority to withheld funds.* The Department has priority to funds withheld or to be withheld in accordance with paragraph

2.a. of this section or Section V, paragraph 3.a., or both, over claims to those funds by:

- (1) A contractor's surety(ies), including without limitation performance bond sureties and payment bond sureties;
- (2) A contracting agency for its reprourement costs;
- (3) A trustee(s) (either a court-appointed trustee or a U.S. trustee, or both) in bankruptcy of a contractor, or a contractor's bankruptcy estate;
- (4) A contractor's assignee(s);
- (5) A contractor's successor(s); or
- (6) A claim asserted under the Prompt Payment Act, [31 U.S.C. 3901-3907](#).

3. Records and certified payrolls (29 CFR 5.5)

a. *Basic record requirements (1) Length of record retention.* All regular payrolls and other basic records must be maintained by the contractor and any subcontractor during the course of the work and preserved for all laborers and mechanics working at the site of the work (or otherwise working in construction or development of the project under a development statute) for a period of at least 3 years after all the work on the prime contract is completed.

(2) *Information required.* Such records must contain the name; Social Security number; last known address, telephone number, and email address of each such worker; each worker's correct classification(s) of work actually performed; hourly rates of wages paid (including rates of contributions or costs anticipated for bona fide fringe benefits or cash equivalents thereof of the types described in [40 U.S.C. 3141\(2\)\(B\)](#) of the Davis-Bacon Act); daily and weekly number of hours actually worked in total and on each covered contract; deductions made; and actual wages paid.

(3) *Additional records relating to fringe benefits.* Whenever the Secretary of Labor has found under paragraph 1.e. of this section that the wages of any laborer or mechanic include the amount of any costs reasonably anticipated in providing benefits under a plan or program described in [40 U.S.C. 3141\(2\)\(B\)](#) of the Davis-Bacon Act, the contractor must maintain records which show that the commitment to provide such benefits is enforceable, that the plan or program is financially responsible, and that the plan or program has been communicated in writing to the laborers or mechanics affected, and records which show the costs anticipated or the actual cost incurred in providing such benefits.

(4) *Additional records relating to apprenticeship.* Contractors with apprentices working under approved programs must maintain written evidence of the registration of apprenticeship programs, the registration of the apprentices, and the ratios and wage rates prescribed in the applicable programs.

b. *Certified payroll requirements (1) Frequency and method of submission.* The contractor or subcontractor must submit weekly, for each week in which any DBA- or Related Acts-covered work is performed, certified payrolls to the contracting

agency. The prime contractor is responsible for the submission of all certified payrolls by all subcontractors. A contracting agency or prime contractor may permit or require contractors to submit certified payrolls through an electronic system, as long as the electronic system requires a legally valid electronic signature; the system allows the contractor, the contracting agency, and the Department of Labor to access the certified payrolls upon request for at least 3 years after the work on the prime contract has been completed; and the contracting agency or prime contractor permits other methods of submission in situations where the contractor is unable or limited in its ability to use or access the electronic system.

(2) *Information required.* The certified payrolls submitted must set out accurately and completely all of the information required to be maintained under paragraph 3.a.(2) of this section, except that full Social Security numbers and last known addresses, telephone numbers, and email addresses must not be included on weekly transmittals. Instead, the certified payrolls need only include an individually identifying number for each worker (e.g., the last four digits of the worker's Social Security number). The required weekly certified payroll information may be submitted using Optional Form WH-347 or in any other format desired. Optional Form WH-347 is available for this purpose from the Wage and Hour Division website at <https://www.dol.gov/sites/dolgov/files/WHDL/legacy/files/wh347/.pdf> or its successor website. It is not a violation of this section for a prime contractor to require a subcontractor to provide full Social Security numbers and last known addresses, telephone numbers, and email addresses to the prime contractor for its own records, without weekly submission by the subcontractor to the contracting agency.

(3) *Statement of Compliance.* Each certified payroll submitted must be accompanied by a "Statement of Compliance," signed by the contractor or subcontractor, or the contractor's or subcontractor's agent who pays or supervises the payment of the persons working on the contract, and must certify the following:

(i) That the certified payroll for the payroll period contains the information required to be provided under paragraph 3.b. of this section, the appropriate information and basic records are being maintained under paragraph 3.a. of this section, and such information and records are correct and complete;

(ii) That each laborer or mechanic (including each helper and apprentice) working on the contract during the payroll period has been paid the full weekly wages earned, without rebate, either directly or indirectly, and that no deductions have been made either directly or indirectly from the full wages earned, other than permissible deductions as set forth in [29 CFR part 3](#); and

(iii) That each laborer or mechanic has been paid not less than the applicable wage rates and fringe benefits or cash equivalents for the classification(s) of work actually performed, as specified in the applicable wage determination incorporated into the contract.

(4) *Use of Optional Form WH-347.* The weekly submission of a properly executed certification set forth on the reverse side of Optional Form WH-347 will satisfy the requirement for submission of the "Statement of Compliance" required by paragraph 3.b.(3) of this section.

(5) *Signature.* The signature by the contractor, subcontractor, or the contractor's or subcontractor's agent must be an original handwritten signature or a legally valid electronic signature.

(6) *Falsification.* The falsification of any of the above certifications may subject the contractor or subcontractor to civil or criminal prosecution under [18 U.S.C. 1001](#) and [31 U.S.C. 3729](#).

(7) *Length of certified payroll retention.* The contractor or subcontractor must preserve all certified payrolls during the course of the work and for a period of 3 years after all the work on the prime contract is completed.

c. *Contracts, subcontracts, and related documents.* The contractor or subcontractor must maintain this contract or subcontract and related documents including, without limitation, bids, proposals, amendments, modifications, and extensions. The contractor or subcontractor must preserve these contracts, subcontracts, and related documents during the course of the work and for a period of 3 years after all the work on the prime contract is completed.

d. *Required disclosures and access* (1) *Required record disclosures and access to workers.* The contractor or subcontractor must make the records required under paragraphs 3.a. through 3.c. of this section, and any other documents that the contracting agency, the State DOT, the FHWA, or the Department of Labor deems necessary to determine compliance with the labor standards provisions of any of the applicable statutes referenced by § 5.1, available for inspection, copying, or transcription by authorized representatives of the contracting agency, the State DOT, the FHWA, or the Department of Labor, and must permit such representatives to interview workers during working hours on the job.

(2) *Sanctions for non-compliance with records and worker access requirements.* If the contractor or subcontractor fails to submit the required records or to make them available, or refuses to permit worker interviews during working hours on the job, the Federal agency may, after written notice to the contractor, sponsor, applicant, owner, or other entity, as the case may be, that maintains such records or that employs such workers, take such action as may be necessary to cause the suspension of any further payment, advance, or guarantee of funds. Furthermore, failure to submit the required records upon request or to make such records available, or to permit worker interviews during working hours on the job, may be grounds for debarment action pursuant to § 5.12. In addition, any contractor or other person that fails to submit the required records or make those records available to WHD within the time WHD requests that the records be produced will be precluded from introducing as evidence in an administrative proceeding under [29 CFR part 6](#) any of the required records that were not provided or made available to WHD. WHD will take into consideration a reasonable request from the contractor or person for an extension of the time for submission of records. WHD will determine the reasonableness of the request and may consider, among other things, the location of the records and the volume of production.

(3) *Required information disclosures.* Contractors and subcontractors must maintain the full Social Security number and last known address, telephone number, and email address

of each covered worker, and must provide them upon request to the contracting agency, the State DOT, the FHWA, the contractor, or the Wage and Hour Division of the Department of Labor for purposes of an investigation or other compliance action.

4. Apprentices and equal employment opportunity (29 CFR 5.5)

a. *Apprentices* (1) *Rate of pay.* Apprentices will be permitted to work at less than the predetermined rate for the work they perform when they are employed pursuant to and individually registered in a bona fide apprenticeship program registered with the U.S. Department of Labor, Employment and Training Administration, Office of Apprenticeship (OA), or with a State Apprenticeship Agency recognized by the OA. A person who is not individually registered in the program, but who has been certified by the OA or a State Apprenticeship Agency (where appropriate) to be eligible for probationary employment as an apprentice, will be permitted to work at less than the predetermined rate for the work they perform in the first 90 days of probationary employment as an apprentice in such a program. In the event the OA or a State Apprenticeship Agency recognized by the OA withdraws approval of an apprenticeship program, the contractor will no longer be permitted to use apprentices at less than the applicable predetermined rate for the work performed until an acceptable program is approved.

(2) *Fringe benefits.* Apprentices must be paid fringe benefits in accordance with the provisions of the apprenticeship program. If the apprenticeship program does not specify fringe benefits, apprentices must be paid the full amount of fringe benefits listed on the wage determination for the applicable classification. If the Administrator determines that a different practice prevails for the applicable apprentice classification, fringe benefits must be paid in accordance with that determination.

(3) *Apprenticeship ratio.* The allowable ratio of apprentices to journeyworkers on the job site in any craft classification must not be greater than the ratio permitted to the contractor as to the entire work force under the registered program or the ratio applicable to the locality of the project pursuant to paragraph 4.a.(4) of this section. Any worker listed on a payroll at an apprentice wage rate, who is not registered or otherwise employed as stated in paragraph 4.a.(1) of this section, must be paid not less than the applicable wage rate on the wage determination for the classification of work actually performed. In addition, any apprentice performing work on the job site in excess of the ratio permitted under this section must be paid not less than the applicable wage rate on the wage determination for the work actually performed.

(4) *Reciprocity of ratios and wage rates.* Where a contractor is performing construction on a project in a locality other than the locality in which its program is registered, the ratios and wage rates (expressed in percentages of the journeyworker's hourly rate) applicable within the locality in which the construction is being performed must be observed. If there is no applicable ratio or wage rate for the locality of the project, the ratio and wage rate specified in the contractor's registered program must be observed.

b. *Equal employment opportunity.* The use of apprentices and journeyworkers under this part must be in conformity with

the equal employment opportunity requirements of Executive Order 11246, as amended, and [29 CFR part 30](#).

c. Apprentices and Trainees (programs of the U.S. DOT).

Apprentices and trainees working under apprenticeship and skill training programs which have been certified by the Secretary of Transportation as promoting EEO in connection with Federal-aid highway construction programs are not subject to the requirements of paragraph 4 of this Section IV. 23 CFR 230.111(e)(2). The straight time hourly wage rates for apprentices and trainees under such programs will be established by the particular programs. The ratio of apprentices and trainees to journeyworkers shall not be greater than permitted by the terms of the particular program.

5. Compliance with Copeland Act requirements. The contractor shall comply with the requirements of 29 CFR part 3, which are incorporated by reference in this contract as provided in 29 CFR 5.5.

6. Subcontracts. The contractor or subcontractor must insert FHWA-1273 in any subcontracts, along with the applicable wage determination(s) and such other clauses or contract modifications as the contracting agency may by appropriate instructions require, and a clause requiring the subcontractors to include these clauses and wage determination(s) in any lower tier subcontracts. The prime contractor is responsible for the compliance by any subcontractor or lower tier subcontractor with all the contract clauses in this section. In the event of any violations of these clauses, the prime contractor and any subcontractor(s) responsible will be liable for any unpaid wages and monetary relief, including interest from the date of the underpayment or loss, due to any workers of lower-tier subcontractors, and may be subject to debarment, as appropriate. 29 CFR 5.5.

7. Contract termination; debarment. A breach of the contract clauses in 29 CFR 5.5 may be grounds for termination of the contract, and for debarment as a contractor and a subcontractor as provided in 29 CFR 5.12.

8. Compliance with Davis-Bacon and Related Act requirements. All rulings and interpretations of the Davis-Bacon and Related Acts contained in 29 CFR parts 1, 3, and 5 are herein incorporated by reference in this contract as provided in 29 CFR 5.5.

9. Disputes concerning labor standards. As provided in 29 CFR 5.5, disputes arising out of the labor standards provisions of this contract shall not be subject to the general disputes clause of this contract. Such disputes shall be resolved in accordance with the procedures of the Department of Labor set forth in 29 CFR parts 5, 6, and 7. Disputes within the meaning of this clause include disputes between the contractor (or any of its subcontractors) and the contracting agency, the U.S. Department of Labor, or the employees or their representatives.

10. Certification of eligibility. a. By entering into this contract, the contractor certifies that neither it nor any person or firm who has an interest in the contractor's firm is a person or firm ineligible to be awarded Government contracts by virtue of [40 U.S.C. 3144\(b\)](#) or § 5.12(a).

b. No part of this contract shall be subcontracted to any person or firm ineligible for award of a Government contract by virtue of [40 U.S.C. 3144\(b\)](#) or § 5.12(a).

c. The penalty for making false statements is prescribed in the U.S. Code, Title 18 Crimes and Criminal Procedure, [18 U.S.C. 1001](#).

11. Anti-retaliation. It is unlawful for any person to discharge, demote, intimidate, threaten, restrain, coerce, blacklist, harass, or in any other manner discriminate against, or to cause any person to discharge, demote, intimidate, threaten, restrain, coerce, blacklist, harass, or in any other manner discriminate against, any worker or job applicant for:

a. Notifying any contractor of any conduct which the worker reasonably believes constitutes a violation of the DBA, Related Acts, this part, or [29 CFR part 1](#) or [3](#);

b. Filing any complaint, initiating or causing to be initiated any proceeding, or otherwise asserting or seeking to assert on behalf of themselves or others any right or protection under the DBA, Related Acts, this part, or [29 CFR part 1](#) or [3](#);

c. Cooperating in any investigation or other compliance action, or testifying in any proceeding under the DBA, Related Acts, this part, or [29 CFR part 1](#) or [3](#); or

d. Informing any other person about their rights under the DBA, Related Acts, this part, or [29 CFR part 1](#) or [3](#).

V. CONTRACT WORK HOURS AND SAFETY STANDARDS ACT

Pursuant to 29 CFR 5.5(b), the following clauses apply to any Federal-aid construction contract in an amount in excess of \$100,000 and subject to the overtime provisions of the Contract Work Hours and Safety Standards Act. These clauses shall be inserted in addition to the clauses required by 29 CFR 5.5(a) or 29 CFR 4.6. As used in this paragraph, the terms laborers and mechanics include watchpersons and guards.

1. Overtime requirements. No contractor or subcontractor contracting for any part of the contract work which may require or involve the employment of laborers or mechanics shall require or permit any such laborer or mechanic in any workweek in which he or she is employed on such work to work in excess of forty hours in such workweek unless such laborer or mechanic receives compensation at a rate not less than one and one-half times the basic rate of pay for all hours worked in excess of forty hours in such workweek. 29 CFR 5.5.

2. Violation; liability for unpaid wages; liquidated damages. In the event of any violation of the clause set forth in paragraph 1. of this section the contractor and any subcontractor responsible therefor shall be liable for the unpaid wages and interest from the date of the underpayment. In addition, such contractor and subcontractor shall be liable to the United States (in the case of work done under contract for the District of Columbia or a territory, to such District or to such territory), for liquidated damages. Such liquidated damages shall be computed with respect to each individual laborer or

mechanic, including watchpersons and guards, employed in violation of the clause set forth in paragraph 1. of this section, in the sum currently provided in 29 CFR 5.5(b)(2)* for each calendar day on which such individual was required or permitted to work in excess of the standard workweek of forty hours without payment of the overtime wages required by the clause set forth in paragraph 1. of this section.

* §31 as of January 15, 2023 (See 88 FR 88 FR 2210) as may be adjusted annually by the Department of Labor, pursuant to the Federal Civil Penalties Inflation Adjustment Act of 1990.

3. Withholding for unpaid wages and liquidated damages

a. *Withholding process.* The FHWA or the contracting agency may, upon its own action, or must, upon written request of an authorized representative of the Department of Labor, withhold or cause to be withheld from the contractor so much of the accrued payments or advances as may be considered necessary to satisfy the liabilities of the prime contractor or any subcontractor for any unpaid wages; monetary relief, including interest; and liquidated damages required by the clauses set forth in this section on this contract, any other Federal contract with the same prime contractor, or any other federally assisted contract subject to the Contract Work Hours and Safety Standards Act that is held by the same prime contractor (as defined in § 5.2). The necessary funds may be withheld from the contractor under this contract, any other Federal contract with the same prime contractor, or any other federally assisted contract that is subject to the Contract Work Hours and Safety Standards Act and is held by the same prime contractor, regardless of whether the other contract was awarded or assisted by the same agency, and such funds may be used to satisfy the contractor liability for which the funds were withheld.

b. *Priority to withheld funds.* The Department has priority to funds withheld or to be withheld in accordance with Section IV paragraph 2.a. or paragraph 3.a. of this section, or both, over claims to those funds by:

- (1) A contractor's surety(ies), including without limitation performance bond sureties and payment bond sureties;
- (2) A contracting agency for its reprourement costs;
- (3) A trustee(s) (either a court-appointed trustee or a U.S. trustee, or both) in bankruptcy of a contractor, or a contractor's bankruptcy estate;
- (4) A contractor's assignee(s);
- (5) A contractor's successor(s); or
- (6) A claim asserted under the Prompt Payment Act, [31 U.S.C. 3901–3907](#).

4. **Subcontracts.** The contractor or subcontractor must insert in any subcontracts the clauses set forth in paragraphs 1. through 5. of this section and a clause requiring the subcontractors to include these clauses in any lower tier subcontracts. The prime contractor is responsible for compliance by any subcontractor or lower tier subcontractor with the clauses set forth in paragraphs 1. through 5. In the

event of any violations of these clauses, the prime contractor and any subcontractor(s) responsible will be liable for any unpaid wages and monetary relief, including interest from the date of the underpayment or loss, due to any workers of lower-tier subcontractors, and associated liquidated damages and may be subject to debarment, as appropriate.

5. **Anti-retaliation.** It is unlawful for any person to discharge, demote, intimidate, threaten, restrain, coerce, blacklist, harass, or in any other manner discriminate against, or to cause any person to discharge, demote, intimidate, threaten, restrain, coerce, blacklist, harass, or in any other manner discriminate against, any worker or job applicant for:

- a. Notifying any contractor of any conduct which the worker reasonably believes constitutes a violation of the Contract Work Hours and Safety Standards Act (CWHSSA) or its implementing regulations in this part;
- b. Filing any complaint, initiating or causing to be initiated any proceeding, or otherwise asserting or seeking to assert on behalf of themselves or others any right or protection under CWHSSA or this part;
- c. Cooperating in any investigation or other compliance action, or testifying in any proceeding under CWHSSA or this part; or
- d. Informing any other person about their rights under CWHSSA or this part.

VI. SUBLETTING OR ASSIGNING THE CONTRACT

This provision is applicable to all Federal-aid construction contracts on the National Highway System pursuant to 23 CFR 635.116.

1. The contractor shall perform with its own organization contract work amounting to not less than 30 percent (or a greater percentage if specified elsewhere in the contract) of the total original contract price, excluding any specialty items designated by the contracting agency. Specialty items may be performed by subcontract and the amount of any such specialty items performed may be deducted from the total original contract price before computing the amount of work required to be performed by the contractor's own organization (23 CFR 635.116).

a. The term "perform work with its own organization" in paragraph 1 of Section VI refers to workers employed or leased by the prime contractor, and equipment owned or rented by the prime contractor, with or without operators. Such term does not include employees or equipment of a subcontractor or lower tier subcontractor, agents of the prime contractor, or any other assignees. The term may include payments for the costs of hiring leased employees from an employee leasing firm meeting all relevant Federal and State regulatory requirements. Leased employees may only be included in this term if the prime contractor meets all of the following conditions: (based on longstanding interpretation)

- (1) the prime contractor maintains control over the supervision of the day-to-day activities of the leased employees;
- (2) the prime contractor remains responsible for the quality of the work of the leased employees;

- (3) the prime contractor retains all power to accept or exclude individual employees from work on the project; and
- (4) the prime contractor remains ultimately responsible for the payment of predetermined minimum wages, the submission of payrolls, statements of compliance and all other Federal regulatory requirements.

b. "Specialty Items" shall be construed to be limited to work that requires highly specialized knowledge, abilities, or equipment not ordinarily available in the type of contracting organizations qualified and expected to bid or propose on the contract as a whole and in general are to be limited to minor components of the overall contract. 23 CFR 635.102.

2. Pursuant to 23 CFR 635.116(a), the contract amount upon which the requirements set forth in paragraph (1) of Section VI is computed includes the cost of material and manufactured products which are to be purchased or produced by the contractor under the contract provisions.

3. Pursuant to 23 CFR 635.116(c), the contractor shall furnish (a) a competent superintendent or supervisor who is employed by the firm, has full authority to direct performance of the work in accordance with the contract requirements, and is in charge of all construction operations (regardless of who performs the work) and (b) such other of its own organizational resources (supervision, management, and engineering services) as the contracting officer determines is necessary to assure the performance of the contract.

4. No portion of the contract shall be sublet, assigned or otherwise disposed of except with the written consent of the contracting officer, or authorized representative, and such consent when given shall not be construed to relieve the contractor of any responsibility for the fulfillment of the contract. Written consent will be given only after the contracting agency has assured that each subcontract is evidenced in writing and that it contains all pertinent provisions and requirements of the prime contract. (based on long-standing interpretation of 23 CFR 635.116).

5. The 30-percent self-performance requirement of paragraph (1) is not applicable to design-build contracts; however, contracting agencies may establish their own self-performance requirements. 23 CFR 635.116(d).

VII. SAFETY: ACCIDENT PREVENTION

This provision is applicable to all Federal-aid construction contracts and to all related subcontracts.

1. In the performance of this contract the contractor shall comply with all applicable Federal, State, and local laws governing safety, health, and sanitation (23 CFR Part 635). The contractor shall provide all safeguards, safety devices and protective equipment and take any other needed actions as it determines, or as the contracting officer may determine, to be reasonably necessary to protect the life and health of employees on the job and the safety of the public and to protect property in connection with the performance of the work covered by the contract. 23 CFR 635.108.

2. It is a condition of this contract, and shall be made a condition of each subcontract, which the contractor enters into pursuant to this contract, that the contractor and any subcontractor shall not permit any employee, in performance of the contract, to work in surroundings or under conditions which are unsanitary, hazardous or dangerous to his/her health or safety, as determined under construction safety and

health standards (29 CFR Part 1926) promulgated by the Secretary of Labor, in accordance with Section 107 of the Contract Work Hours and Safety Standards Act (40 U.S.C. 3704). 29 CFR 1926.10.

3. Pursuant to 29 CFR 1926.3, it is a condition of this contract that the Secretary of Labor or authorized representative thereof, shall have right of entry to any site of contract performance to inspect or investigate the matter of compliance with the construction safety and health standards and to carry out the duties of the Secretary under Section 107 of the Contract Work Hours and Safety Standards Act (40 U.S.C. 3704).

VIII. FALSE STATEMENTS CONCERNING HIGHWAY PROJECTS

This provision is applicable to all Federal-aid construction contracts and to all related subcontracts.

In order to assure high quality and durable construction in conformity with approved plans and specifications and a high degree of reliability on statements and representations made by engineers, contractors, suppliers, and workers on Federal-aid highway projects, it is essential that all persons concerned with the project perform their functions as carefully, thoroughly, and honestly as possible. Willful falsification, distortion, or misrepresentation with respect to any facts related to the project is a violation of Federal law. To prevent any misunderstanding regarding the seriousness of these and similar acts, Form FHWA-1022 shall be posted on each Federal-aid highway project (23 CFR Part 635) in one or more places where it is readily available to all persons concerned with the project:

18 U.S.C. 1020 reads as follows:

"Whoever, being an officer, agent, or employee of the United States, or of any State or Territory, or whoever, whether a person, association, firm, or corporation, knowingly makes any false statement, false representation, or false report as to the character, quality, quantity, or cost of the material used or to be used, or the quantity or quality of the work performed or to be performed, or the cost thereof in connection with the submission of plans, maps, specifications, contracts, or costs of construction on any highway or related project submitted for approval to the Secretary of Transportation; or

Whoever knowingly makes any false statement, false representation, false report or false claim with respect to the character, quality, quantity, or cost of any work performed or to be performed, or materials furnished or to be furnished, in connection with the construction of any highway or related project approved by the Secretary of Transportation; or

Whoever knowingly makes any false statement or false representation as to material fact in any statement, certificate, or report submitted pursuant to provisions of the Federal-aid Roads Act approved July 11, 1916, (39 Stat. 355), as amended and supplemented;

Shall be fined under this title or imprisoned not more than 5 years or both."

IX. IMPLEMENTATION OF CLEAN AIR ACT AND FEDERAL WATER POLLUTION CONTROL ACT (42 U.S.C. 7606; 2 CFR 200.88; EO 11738)

This provision is applicable to all Federal-aid construction contracts in excess of \$150,000 and to all related subcontracts. 48 CFR 2.101; 2 CFR 200.327.

By submission of this bid/proposal or the execution of this contract or subcontract, as appropriate, the bidder, proposer, Federal-aid construction contractor, subcontractor, supplier, or vendor agrees to comply with all applicable standards, orders or regulations issued pursuant to the Clean Air Act (42 U.S.C. 7401-7671q) and the Federal Water Pollution Control Act, as amended (33 U.S.C. 1251-1387). Violations must be reported to the Federal Highway Administration and the Regional Office of the Environmental Protection Agency. 2 CFR Part 200, Appendix II.

The contractor agrees to include or cause to be included the requirements of this Section in every subcontract, and further agrees to take such action as the contracting agency may direct as a means of enforcing such requirements. 2 CFR 200.327.

X. CERTIFICATION REGARDING DEBARMENT, SUSPENSION, INELIGIBILITY AND VOLUNTARY EXCLUSION

This provision is applicable to all Federal-aid construction contracts, design-build contracts, subcontracts, lower-tier subcontracts, purchase orders, lease agreements, consultant contracts or any other covered transaction requiring FHWA approval or that is estimated to cost \$25,000 or more – as defined in 2 CFR Parts 180 and 1200. 2 CFR 180.220 and 1200.220.

1. Instructions for Certification – First Tier Participants:

a. By signing and submitting this proposal, the prospective first tier participant is providing the certification set out below.

b. The inability of a person to provide the certification set out below will not necessarily result in denial of participation in this covered transaction. The prospective first tier participant shall submit an explanation of why it cannot provide the certification set out below. The certification or explanation will be considered in connection with the department or agency's determination whether to enter into this transaction. However, failure of the prospective first tier participant to furnish a certification or an explanation shall disqualify such a person from participation in this transaction. 2 CFR 180.320.

c. The certification in this clause is a material representation of fact upon which reliance was placed when the contracting agency determined to enter into this transaction. If it is later determined that the prospective participant knowingly rendered an erroneous certification, in addition to other remedies available to the Federal Government, the contracting agency may terminate this transaction for cause of default. 2 CFR 180.325.

d. The prospective first tier participant shall provide immediate written notice to the contracting agency to whom this proposal is submitted if any time the prospective first tier participant learns that its certification was erroneous when submitted or has become erroneous by reason of changed circumstances. 2 CFR 180.345 and 180.350.

e. The terms "covered transaction," "debarred," "suspended," "ineligible," "participant," "person," "principal," and "voluntarily excluded," as used in this clause, are defined in 2 CFR Parts 180, Subpart I, 180.900-180.1020, and 1200. "First Tier Covered Transactions" refers to any covered transaction between a recipient or subrecipient of Federal funds and a participant (such as the prime or general contract). "Lower Tier Covered Transactions" refers to any covered transaction under a First Tier Covered Transaction (such as subcontracts). "First Tier Participant" refers to the participant who has entered into a covered transaction with a recipient or subrecipient of Federal funds (such as the prime or general contractor). "Lower Tier Participant" refers any participant who has entered into a covered transaction with a First Tier Participant or other Lower Tier Participants (such as subcontractors and suppliers).

f. The prospective first tier participant agrees by submitting this proposal that, should the proposed covered transaction be entered into, it shall not knowingly enter into any lower tier covered transaction with a person who is debarred, suspended, declared ineligible, or voluntarily excluded from participation in this covered transaction, unless authorized by the department or agency entering into this transaction. 2 CFR 180.330.

g. The prospective first tier participant further agrees by submitting this proposal that it will include the clause titled "Certification Regarding Debarment, Suspension, Ineligibility and Voluntary Exclusion-Lower Tier Covered Transactions," provided by the department or contracting agency, entering into this covered transaction, without modification, in all lower tier covered transactions and in all solicitations for lower tier covered transactions exceeding the \$25,000 threshold. 2 CFR 180.220 and 180.300.

h. A participant in a covered transaction may rely upon a certification of a prospective participant in a lower tier covered transaction that is not debarred, suspended, ineligible, or voluntarily excluded from the covered transaction, unless it knows that the certification is erroneous. 2 CFR 180.300; 180.320, and 180.325. A participant is responsible for ensuring that its principals are not suspended, debarred, or otherwise ineligible to participate in covered transactions. 2 CFR 180.335. To verify the eligibility of its principals, as well as the eligibility of any lower tier prospective participants, each participant may, but is not required to, check the System for Award Management website (<https://www.sam.gov/>). 2 CFR 180.300, 180.320, and 180.325.

i. Nothing contained in the foregoing shall be construed to require the establishment of a system of records in order to render in good faith the certification required by this clause. The knowledge and information of the prospective participant is not required to exceed that which is normally possessed by a prudent person in the ordinary course of business dealings.

j. Except for transactions authorized under paragraph (f) of these instructions, if a participant in a covered transaction knowingly enters into a lower tier covered transaction with a person who is suspended, debarred, ineligible, or voluntarily excluded from participation in this transaction, in addition to other remedies available to the Federal Government, the department or agency may terminate this transaction for cause or default. 2 CFR 180.325.

2. Certification Regarding Debarment, Suspension, Ineligibility and Voluntary Exclusion – First Tier Participants:

a. The prospective first tier participant certifies to the best of its knowledge and belief, that it and its principals:

(1) Are not presently debarred, suspended, proposed for debarment, declared ineligible, or voluntarily excluded from participating in covered transactions by any Federal department or agency, 2 CFR 180.335;

(2) Have not within a three-year period preceding this proposal been convicted of or had a civil judgment rendered against them for commission of fraud or a criminal offense in connection with obtaining, attempting to obtain, or performing a public (Federal, State, or local) transaction or contract under a public transaction; violation of Federal or State antitrust statutes or commission of embezzlement, theft, forgery, bribery, falsification or destruction of records, making false statements, or receiving stolen property, 2 CFR 180.800;

(3) Are not presently indicted for or otherwise criminally or civilly charged by a governmental entity (Federal, State or local) with commission of any of the offenses enumerated in paragraph (a)(2) of this certification, 2 CFR 180.700 and 180.800; and

(4) Have not within a three-year period preceding this application/proposal had one or more public transactions (Federal, State or local) terminated for cause or default. 2 CFR 180.335(d).

(5) Are not a corporation that has been convicted of a felony violation under any Federal law within the two-year period preceding this proposal (USDOT Order 4200.6 implementing appropriations act requirements); and

(6) Are not a corporation with any unpaid Federal tax liability that has been assessed, for which all judicial and administrative remedies have been exhausted, or have lapsed, and that is not being paid in a timely manner pursuant to an agreement with the authority responsible for collecting the tax liability (USDOT Order 4200.6 implementing appropriations act requirements).

b. Where the prospective participant is unable to certify to any of the statements in this certification, such prospective participant should attach an explanation to this proposal. 2 CFR 180.335 and 180.340.

3. Instructions for Certification – Lower Tier Participants:

(Applicable to all subcontracts, purchase orders, and other lower tier transactions requiring prior FHWA approval or estimated to cost \$25,000 or more - 2 CFR Parts 180 and 1200). 2 CFR 180.220 and 1200.220.

a. By signing and submitting this proposal, the prospective lower tier participant is providing the certification set out below.

b. The certification in this clause is a material representation of fact upon which reliance was placed when this transaction was entered into. If it is later determined that the prospective lower tier participant knowingly rendered an erroneous certification, in addition to other remedies available to the Federal Government, the department, or agency with which

this transaction originated may pursue available remedies, including suspension and/or debarment.

c. The prospective lower tier participant shall provide immediate written notice to the person to which this proposal is submitted if at any time the prospective lower tier participant learns that its certification was erroneous by reason of changed circumstances. 2 CFR 180.365.

d. The terms "covered transaction," "debarred," "suspended," "ineligible," "participant," "person," "principal," and "voluntarily excluded," as used in this clause, are defined in 2 CFR Parts 180, Subpart I, 180.900 – 180.1020, and 1200. You may contact the person to which this proposal is submitted for assistance in obtaining a copy of those regulations. "First Tier Covered Transactions" refers to any covered transaction between a recipient or subrecipient of Federal funds and a participant (such as the prime or general contract). "Lower Tier Covered Transactions" refers to any covered transaction under a First Tier Covered Transaction (such as subcontracts). "First Tier Participant" refers to the participant who has entered into a covered transaction with a recipient or subrecipient of Federal funds (such as the prime or general contractor). "Lower Tier Participant" refers any participant who has entered into a covered transaction with a First Tier Participant or other Lower Tier Participants (such as subcontractors and suppliers).

e. The prospective lower tier participant agrees by submitting this proposal that, should the proposed covered transaction be entered into, it shall not knowingly enter into any lower tier covered transaction with a person who is debarred, suspended, declared ineligible, or voluntarily excluded from participation in this covered transaction, unless authorized by the department or agency with which this transaction originated. 2 CFR 1200.220 and 1200.332.

f. The prospective lower tier participant further agrees by submitting this proposal that it will include this clause titled "Certification Regarding Debarment, Suspension, Ineligibility and Voluntary Exclusion-Lower Tier Covered Transaction," without modification, in all lower tier covered transactions and in all solicitations for lower tier covered transactions exceeding the \$25,000 threshold. 2 CFR 180.220 and 1200.220.

g. A participant in a covered transaction may rely upon a certification of a prospective participant in a lower tier covered transaction that is not debarred, suspended, ineligible, or voluntarily excluded from the covered transaction, unless it knows that the certification is erroneous. A participant is responsible for ensuring that its principals are not suspended, debarred, or otherwise ineligible to participate in covered transactions. To verify the eligibility of its principals, as well as the eligibility of any lower tier prospective participants, each participant may, but is not required to, check the System for Award Management website (<https://www.sam.gov/>), which is compiled by the General Services Administration. 2 CFR 180.300, 180.320, 180.330, and 180.335.

h. Nothing contained in the foregoing shall be construed to require establishment of a system of records in order to render in good faith the certification required by this clause. The knowledge and information of participant is not required to exceed that which is normally possessed by a prudent person in the ordinary course of business dealings.

i. Except for transactions authorized under paragraph e of these instructions, if a participant in a covered transaction knowingly enters into a lower tier covered transaction with a person who is suspended, debarred, ineligible, or voluntarily

excluded from participation in this transaction, in addition to other remedies available to the Federal Government, the department or agency with which this transaction originated may pursue available remedies, including suspension and/or debarment. 2 CFR 180.325.

* * * * *

4. Certification Regarding Debarment, Suspension, Ineligibility and Voluntary Exclusion--Lower Tier Participants:

a. The prospective lower tier participant certifies, by submission of this proposal, that neither it nor its principals:

(1) is presently debarred, suspended, proposed for debarment, declared ineligible, or voluntarily excluded from participating in covered transactions by any Federal department or agency, 2 CFR 180.355;

(2) is a corporation that has been convicted of a felony violation under any Federal law within the two-year period preceding this proposal (USDOT Order 4200.6 implementing appropriations act requirements); and

(3) is a corporation with any unpaid Federal tax liability that has been assessed, for which all judicial and administrative remedies have been exhausted, or have lapsed, and that is not being paid in a timely manner pursuant to an agreement with the authority responsible for collecting the tax liability. (USDOT Order 4200.6 implementing appropriations act requirements)

b. Where the prospective lower tier participant is unable to certify to any of the statements in this certification, such prospective participant should attach an explanation to this proposal.

* * * * *

XI. CERTIFICATION REGARDING USE OF CONTRACT FUNDS FOR LOBBYING

This provision is applicable to all Federal-aid construction contracts and to all related subcontracts which exceed \$100,000. 49 CFR Part 20, App. A.

1. The prospective participant certifies, by signing and submitting this bid or proposal, to the best of his or her knowledge and belief, that:

a. No Federal appropriated funds have been paid or will be paid, by or on behalf of the undersigned, to any person for influencing or attempting to influence an officer or employee of any Federal agency, a Member of Congress, an officer or employee of Congress, or an employee of a Member of Congress in connection with the awarding of any Federal contract, the making of any Federal grant, the making of any Federal loan, the entering into of any cooperative agreement, and the extension, continuation, renewal, amendment, or modification of any Federal contract, grant, loan, or cooperative agreement.

b. If any funds other than Federal appropriated funds have been paid or will be paid to any person for influencing or attempting to influence an officer or employee of any Federal agency, a Member of Congress, an officer or employee of Congress, or an employee of a Member of Congress in connection with this Federal contract, grant, loan, or

cooperative agreement, the undersigned shall complete and submit Standard Form-LLL, "Disclosure Form to Report Lobbying," in accordance with its instructions.

2. This certification is a material representation of fact upon which reliance was placed when this transaction was made or entered into. Submission of this certification is a prerequisite for making or entering into this transaction imposed by 31 U.S.C. 1352. Any person who fails to file the required certification shall be subject to a civil penalty of not less than \$10,000 and not more than \$100,000 for each such failure.

3. The prospective participant also agrees by submitting its bid or proposal that the participant shall require that the language of this certification be included in all lower tier subcontracts, which exceed \$100,000 and that all such recipients shall certify and disclose accordingly.

XII. USE OF UNITED STATES-FLAG VESSELS:

This provision is applicable to all Federal-aid construction contracts, design-build contracts, subcontracts, lower-tier subcontracts, purchase orders, lease agreements, or any other covered transaction. 46 CFR Part 381.

This requirement applies to material or equipment that is acquired for a specific Federal-aid highway project. 46 CFR 381.7. It is not applicable to goods or materials that come into inventories independent of an FHWA funded-contract.

When oceanic shipments (or shipments across the Great Lakes) are necessary for materials or equipment acquired for a specific Federal-aid construction project, the bidder, proposer, contractor, subcontractor, or vendor agrees:

1. To utilize privately owned United States-flag commercial vessels to ship at least 50 percent of the gross tonnage (computed separately for dry bulk carriers, dry cargo liners, and tankers) involved, whenever shipping any equipment, material, or commodities pursuant to this contract, to the extent such vessels are available at fair and reasonable rates for United States-flag commercial vessels. 46 CFR 381.7.

2. To furnish within 20 days following the date of loading for shipments originating within the United States or within 30 working days following the date of loading for shipments originating outside the United States, a legible copy of a rated, 'on-board' commercial ocean bill-of-lading in English for each shipment of cargo described in paragraph (b)(1) of this section to both the Contracting Officer (through the prime contractor in the case of subcontractor bills-of-lading) and to the Office of Cargo and Commercial Sealift (MAR-620), Maritime Administration, Washington, DC 20590. (MARAD requires copies of the ocean carrier's (master) bills of lading, certified onboard, dated, with rates and charges. These bills of lading may contain business sensitive information and therefore may be submitted directly to MARAD by the Ocean Transportation Intermediary on behalf of the contractor). 46 CFR 381.7.

**ATTACHMENT A - EMPLOYMENT AND MATERIALS
PREFERENCE FOR APPALACHIAN DEVELOPMENT
HIGHWAY SYSTEM OR APPALACHIAN LOCAL ACCESS
ROAD CONTRACTS (23 CFR 633, Subpart B, Appendix B)**

This provision is applicable to all Federal-aid projects funded under the Appalachian Regional Development Act of 1965.

1. During the performance of this contract, the contractor undertaking to do work which is, or reasonably may be, done as on-site work, shall give preference to qualified persons who regularly reside in the labor area as designated by the DOL wherein the contract work is situated, or the subregion, or the Appalachian counties of the State wherein the contract work is situated, except:

a. To the extent that qualified persons regularly residing in the area are not available.

b. For the reasonable needs of the contractor to employ supervisory or specially experienced personnel necessary to assure an efficient execution of the contract work.

c. For the obligation of the contractor to offer employment to present or former employees as the result of a lawful collective bargaining contract, provided that the number of nonresident persons employed under this subparagraph (1c) shall not exceed 20 percent of the total number of employees employed by the contractor on the contract work, except as provided in subparagraph (4) below.

2. The contractor shall place a job order with the State Employment Service indicating (a) the classifications of the laborers, mechanics and other employees required to perform the contract work, (b) the number of employees required in each classification, (c) the date on which the participant estimates such employees will be required, and (d) any other pertinent information required by the State Employment Service to complete the job order form. The job order may be placed with the State Employment Service in writing or by telephone. If during the course of the contract work, the information submitted by the contractor in the original job order is substantially modified, the participant shall promptly notify the State Employment Service.

3. The contractor shall give full consideration to all qualified job applicants referred to him by the State Employment Service. The contractor is not required to grant employment to any job applicants who, in his opinion, are not qualified to perform the classification of work required.

4. If, within one week following the placing of a job order by the contractor with the State Employment Service, the State Employment Service is unable to refer any qualified job applicants to the contractor, or less than the number requested, the State Employment Service will forward a certificate to the contractor indicating the unavailability of applicants. Such certificate shall be made a part of the contractor's permanent project records. Upon receipt of this certificate, the contractor may employ persons who do not normally reside in the labor area to fill positions covered by the certificate, notwithstanding the provisions of subparagraph (1c) above.

5. The provisions of 23 CFR 633.207(e) allow the contracting agency to provide a contractual preference for the use of mineral resource materials native to the Appalachian region.

6. The contractor shall include the provisions of Sections 1 through 4 of this Attachment A in every subcontract for work which is, or reasonably may be, done as on-site work.

STANDARD SPECIAL PROVISION**ON-THE-JOB TRAINING**

(10-16-07) (Rev. 4-21-15)

Z-10

Description

The North Carolina Department of Transportation will administer a custom version of the Federal On-the-Job Training (OJT) Program, commonly referred to as the Alternate OJT Program. All contractors (existing and newcomers) will be automatically placed in the Alternate Program. Standard OJT requirements typically associated with individual projects will no longer be applied at the project level. Instead, these requirements will be applicable on an annual basis for each contractor administered by the OJT Program Manager.

On the Job Training shall meet the requirements of 23 CFR 230.107 (b), 23 USC – Section 140, this provision and the On-the-Job Training Program Manual.

The Alternate OJT Program will allow a contractor to train employees on Federal, State and privately funded projects located in North Carolina. However, priority shall be given to training employees on NCDOT Federal-Aid funded projects.

Minorities and Women

Developing, training and upgrading of minorities and women toward journeyman level status is a primary objective of this special training provision. Accordingly, the Contractor shall make every effort to enroll minority and women as trainees to the extent that such persons are available within a reasonable area of recruitment. This training commitment is not intended, and shall not be used, to discriminate against any applicant for training, whether a member of a minority group or not.

Assigning Training Goals

The Department, through the OJT Program Manager, will assign training goals for a calendar year based on the contractors' past three years' activity and the contractors' anticipated upcoming year's activity with the Department. At the beginning of each year, all contractors eligible will be contacted by the Department to determine the number of trainees that will be assigned for the upcoming calendar year. At that time the Contractor shall enter into an agreement with the Department to provide a self-imposed on-the-job training program for the calendar year. This agreement will include a specific number of annual training goals agreed to by both parties. The number of training assignments may range from 1 to 15 per contractor per calendar year. The Contractor shall sign an agreement to fulfill their annual goal for the year.\

Training Classifications

The Contractor shall provide on-the-job training aimed at developing full journeyman level workers in the construction craft/operator positions. Preference shall be given to providing training in the following skilled work classifications:

Equipment Operators	Office Engineers
Truck Drivers	Estimators
Carpenters	Iron / Reinforcing Steel Workers
Concrete Finishers	Mechanics
Pipe Layers	Welders

The Department has established common training classifications and their respective training requirements that may be used by the contractors. However, the classifications established are not all-inclusive. Where the training is oriented toward construction applications, training will be allowed in lower-level management positions such as office engineers and estimators. Contractors shall submit new classifications for specific job functions that their employees are performing. The Department will review and recommend for acceptance to FHWA the new classifications proposed by contractors, if applicable. New classifications shall meet the following requirements:

Proposed training classifications are reasonable and realistic based on the job skill classification needs, and

The number of training hours specified in the training classification is consistent with common practices and provides enough time for the trainee to obtain journeyman level status.

The Contractor may allow trainees to be trained by a subcontractor provided that the Contractor retains primary responsibility for meeting the training and this provision is made applicable to the subcontract. However, only the Contractor will receive credit towards the annual goal for the trainee.

Where feasible, 25 percent of apprentices or trainees in each occupation shall be in their first year of apprenticeship or training. The number of trainees shall be distributed among the work classifications on the basis of the contractor's needs and the availability of journeymen in the various classifications within a reasonable area of recruitment.

No employee shall be employed as a trainee in any classification in which they have successfully completed a training course leading to journeyman level status or in which they have been employed as a journeyman.

Records and Reports

The Contractor shall maintain enrollment, monthly and completion reports documenting company compliance under these contract documents. These documents and any other information as requested shall be submitted to the OJT Program Manager.

Upon completion and graduation of the program, the Contractor shall provide each trainee with a certification Certificate showing the type and length of training satisfactorily completed.

Trainee Interviews

All trainees enrolled in the program will receive an initial and Trainee/Post graduate interview conducted by the OJT program staff.

Trainee Wages

Contractors shall compensate trainees on a graduating pay scale based upon a percentage of the prevailing minimum journeyman wages (Davis-Bacon Act). Minimum pay shall be as follows:

60 percent	of the journeyman wage for the first half of the training period
75 percent	of the journeyman wage for the third quarter of the training period
90 percent	of the journeyman wage for the last quarter of the training period

In no instance shall a trainee be paid less than the local minimum wage. The Contractor shall adhere to the minimum hourly wage rate that will satisfy both the NC Department of Labor (NCDOL) and the Department.

Achieving or Failing to Meet Training Goals

The Contractor will be credited for each trainee employed by him on the contract work who is currently enrolled or becomes enrolled in an approved program and who receives training for at least 50 percent of the specific program requirement. Trainees will be allowed to be transferred between projects if required by the Contractor's scheduled workload to meet training goals.

If a contractor fails to attain their training assignments for the calendar year, they may be taken off the NCDOT's Bidders List.

Measurement and Payment

No compensation will be made for providing required training in accordance with these contract documents.

STANDARD SPECIAL PROVISION
MINIMUM WAGES
GENERAL DECISION NC20230091 01/06/2023 NC91

Z-091

Date: January 6, 2023

General Decision Number: NC20230091 01/06/2023 NC91

Superseded General Decision Numbers: NC20220091

State: North Carolina

Construction Type: HIGHWAY

COUNTIES:

Beaufort	Granville	Pasquotank
Bertie	Halifax	Perquimans
Bladen	Harnett	Robeson
Camden	Hertford	Sampson
Carteret	Hyde	Scotland
Chowan	Jones	Tyrrell
Columbus	Lenoir	Vance
Craven	Martin	Warren
Dare	Northampton	Washington
Duplin	Pamlico	Wilson
Gates		

HIGHWAY CONSTRUCTION PROJECTS (excluding tunnels, building structures in rest area projects & railroad construction; bascule, suspension & spandrel arch bridges designed for commercial navigation, bridges involving marine construction; and other major bridges).

Note: Contracts subject to the Davis-Bacon Act are generally required to pay at least the applicable minimum wage rate required under Executive Order 14026 or Executive Order 13658. Please note that these Executive Orders apply to covered contracts entered into by the federal government that are subject to the Davis-Bacon Act itself, but do not apply to contracts subject only to the Davis-Bacon Related Acts, including those set forth at 29 CFR 5.1(a)(2)-(60).

If the contract is entered into on or after January 30, 2022, or the contract is renewed or extended (e.g., an option is exercised) on or after January 30, 2022:	Executive Order 14026 generally applies to the contract. The contractor must pay all covered workers at least \$16.20 per hour (or the applicable wage rate listed on this wage determination, if it is higher) for all hours spent performing on that contract in 2023.
If the contract was awarded on or between January 1, 2015 and January 29, 2022, and the contract	Executive Order 13658 generally applies to the contract. The contractor must pay all covered workers at least \$12.15 per hour (or the applicable wage rate listed on

If the contract is entered into on or after January 30, 2022, or the contract is renewed or extended (e.g., an option is exercised) on or after January 30, 2022:	Executive Order 14026 generally applies to the contract. The contractor must pay all covered workers at least \$16.20 per hour (or the applicable wage rate listed on this wage determination, if it is higher) for all hours spent performing on that contract in 2023.
is not renewed or extended on or after January 30, 2022:	this wage determination, if it is higher) for all hours spent performing on that contract in 2023.

The applicable Executive Order minimum wage rate will be adjusted annually. If this contract is covered by one of the Executive Orders and a classification considered necessary for performance of work on the contract does not appear on this wage determination, the contractor must still submit a conformance request.

Additional information on contractor requirements and worker protections under the Executive Orders is available at <http://www.dol.gov/whd/govcontracts>.

Modification Number
0

Publication Date
01/06/2023

SUNC2014-006 11/17/2014

	Rates	Fringes
BLASTER	21.85	
CARPENTER	13.72 **	
CEMENT MASON/CONCRETE FINISHER	14.26 **	
ELECTRICIAN		
Electrician	18.69	2.66
Telecommunications Technician	14.72 **	1.67
IRONWORKER	16.32	
LABORER		
Asphalt Raker and Spreader	12.42 **	
Asphalt Screed/Jackman	13.48 **	
Carpenter Tender	10.85 **	
Cement Mason/Concrete Finisher Tender	11.35 **	
Common or General	10.12 **	
Guardrail/Fence Installer	13.39 **	
Pipelayer	13.31 **	
Traffic Signal/Lighting Installer	16.88	
PAINTER		
Bridge	19.62	
POWER EQUIPMENT OPERATORS		
Asphalt Broom Tractor	13.28 **	
Bulldozer Fine	18.46	
Bulldozer Rough	14.09 **	
Concrete Grinder/Groover	24.66	
Crane Boom Trucks	17.25	
Crane Other	21.48	
Crane Rough/All-Terrain	19.00	
Drill Operator Rock	15.43 **	1.61
Drill Operator Structure	19.12	
Excavator Fine	17.61	

	Rates	Fringes
Excavator Rough	12.99 **	
Grader/Blade Fine	16.73	
Grader/Blade Rough	15.28 **	
Loader 2 Cubic Yards or Less	10.28 **	
Loader Greater Than 2 Cubic Yards	13.58 **	
Material Transfer Vehicle (Shuttle Buggy)	17.39	
Mechanic	18.63	
Milling Machine	14.38 **	
Off-Road Hauler/Water Tanker	9.30 **	
Oiler/Greaser	13.45 **	
Pavement Marking Equipment	11.87 **	
Paver Asphalt	15.53 **	
Roller Asphalt Breakdown	12.13 **	
Roller Asphalt Finish	13.65 **	
Roller Other	10.48 **	
Scraper Finish	13.98 **	
Scraper Rough	10.17 **	
Slip Form Machine	19.29	
Tack Truck/Distributor Operator	14.56 **	
TRUCK DRIVER		
GVWR of 26,000 Lbs or Less	10.35 **	
GVWR of 26,001 Lbs or Greater	12.04 **	

Welders – Receive rate prescribed for craft performing operation to which welding is incidental.

** Workers in this classification may be entitled to a higher minimum wage under Executive Order 14026 (\$16.20) or 13658 (\$12.15). Please see the Note at the top of the wage determination for more information.

Note: Executive Order (EO) 13706, Establishing Paid Sick Leave for Federal Contractors applies to all contracts subject to the Davis-Bacon Act for which the contract is awarded (and any solicitation was issued) on or after January 1, 2017. If this contract is covered by the EO, the contractor must provide employees with 1 hour of paid sick leave for every 30 hours they work, up to 56 hours of paid sick leave each year. Employees must be permitted to use paid sick leave for their own illness, injury or other health-related needs, including preventive care; to assist a family member (or person who is like family to the employee) who is ill, injured, or has other health-related needs, including preventive care; or for reasons resulting from, or to assist a family member (or person who is like family to the employee) who is a victim of, domestic violence, sexual assault, or stalking. Additional information on contractor requirements and worker protections under the EO is available at <https://www.dol.gov/agencies/whd/government-contracts>.

Unlisted classifications needed for work not included within the scope of the classifications listed may be added after award only as provided in the labor standards contract clauses (29 CFR 5.5(a)(1)(ii)).

The body of each wage determination lists the classification and wage rates that have been found to be prevailing for the cited type(s) of construction in the area covered by the wage determination. The classifications are listed in alphabetical order of "identifiers" that indicate whether the particular rate is a union rate (current union negotiated rate for local), a survey rate (weighted average rate) or a union average rate (weighted union average rate).

Union Rate Identifiers

A four letter classification abbreviation identifier enclosed in dotted lines beginning with characters other than "SU" or "UAVG" denotes that the union classification and rate were prevailing for that classification in the survey. Example: PLUM0198-005 07/01/2014. PLUM is an abbreviation identifier of the union which prevailed in the survey for this classification, which in this example would be Plumbers. 0198 indicates the local union number or district council number where applicable, i.e., Plumbers Local 0198. The next number, 005 in the example, is an internal number used in processing the wage determination. 07/01/2014 is the effective date of the most current negotiated rate, which in this example is July 1, 2014.

Union prevailing wage rates are updated to reflect all rate changes in the collective bargaining agreement (CBA) governing this classification and rate.

Survey Rate Identifiers

Classifications listed under the "SU" identifier indicate that no one rate prevailed for this classification in the survey and the published rate is derived by computing a weighted average rate based on all the rates reported in the survey for that classification. As this weighted average rate includes all rates reported in the survey, it may include both union and non-union rates. Example: SULA2012-007 5/13/2014. SU indicates the rates are survey rates based on a weighted average calculation of rates and are not majority rates. LA indicates the State of Louisiana. 2012 is the year of survey on which these classifications and rates are based. The next number, 007 in the example, is an internal number used in producing the wage determination. 5/13/2014 indicates the survey completion date for the classifications and rates under that identifier.

Survey wage rates are not updated and remain in effect until a new survey is conducted.

Union Average Rate Identifiers

Classification(s) listed under the UAVG identifier indicate that no single majority rate prevailed for those classifications; however, 100% of the data reported for the classifications was union data. EXAMPLE: UAVG-OH-0010 08/29/2014. UAVG indicates that the rate is a weighted union average rate. OH indicates the state. The next number, 0010 in the example, is an internal number used in producing the wage determination. 08/29/2014 indicates the survey completion date for the classifications and rates under that identifier.

A UAVG rate will be updated once a year, usually in January of each year, to reflect a weighted average of the current negotiated/CBA rate of the union locals from which the rate is based.

WAGE DETERMINATION APPEALS PROCESS

1.) Has there been an initial decision in the matter? This can be:

- * an existing published wage determination
- * a survey underlying a wage determination
- * a Wage and Hour Division letter setting forth a position on a wage determination matter
- * a conformance (additional classification and rate) ruling

On survey related matters, initial contact, including requests for summaries of surveys, should be with the Wage and Hour National Office because National Office has responsibility for the David-

Bacon survey program. If the response from this initial contact is not satisfactory, then the process described in 2.) and 3.) should be followed.

With regard to any other matter not yet ripe for the formal process described here, initial contact should be with the Branch of Construction Wage Determinations. Write to:

Branch of Construction Wage Determinations
Wage and Hour Division
U. S. Department of Labor
200 Constitution Avenue, N.W.
Washington, D.C. 20210

- 2.) If the answer to the question in 1.) is yes, then an interested party (those affected by the action) can request review and reconsideration from the Wage and Hour Administrator (See 29 CFR Part 1.8 and 29 CFR Part 7). Write to:

Wage and Hour Administrator
U.S. Department of Labor
200 Constitution Avenue, N.W.
Washington, D.C. 20210

The request should be accompanied by a full statement of the interested party's position and by any information (wage payment data, project description, area practice material, etc.) that the requestor considers relevant to the issue.

- 3.) If the decision of the Administrator is not favorable, an interested party may appeal directly to the Administrative Review Board (formerly the Wage Appeals Board). Write to:

Administrative Review Board
U.S. Department of Labor
200 Constitution Avenue, N.W.
Washington, D.C. 20210

- 4.) All decisions by the Administrative Review Board are final.

END OF GENERAL DECISION



DocuSigned by:
Matthew V. Springer
 BC60F6E8B584403...
 8/27/2020

POLYUREA PAVEMENT MARKING MEDIA AND THICKNESS:

(08-27-20)

Amend the *NCDOT 2018 Standard Specifications* as follows:

Page 12-8, Subarticle 1205-5(B), lines 14-16, replace with the following:

Produce polyurea pavement marking lines that have a minimum dry thickness of 20 mils above the pavement surface when placed on concrete and asphalt pavements. Produce polyurea pavement marking lines that have a minimum dry thickness of 30 mils above the pavement surface on textured surfaces such as OGFC and on surfaces where the polyurea will be placed over a previously removed pavement marking.

Page 12-9, replace **Table 1205-4 Minimum Reflectometer Requirement for Polyurea** with the following:

TABLE 1205-4 MINIMUM REFLECTOMETER REQUIREMENTS FOR POLYUREA		
Item	Color	Reflectivity
Standard Glass Beads	White	375 mcd/lux/m ²
	Yellow	250 mcd/lux/m ²

The installer may choose to use an AASHTO Type 4/Type 1 or AASHTO Type 3/Type 1 double drop system, but no price adjustment will be made, and these systems will be incidental to the polyurea pavement marking.

Pay Item

Pay Unit

Polyurea Pavement Marking Lines, ___", _____mils
 (Standard Glass Beads)

Linear Foot

TC-1

HI-0016
HI-0017

Robeson and Columbus Counties

WORK ZONE TRAFFIC CONTROL Project Special Provisions Table of Contents

Special Provision	Page
Work Zone Traffic Control for Interstate/Freeway Resurfacing	TC-2
Work Zone Digital Speed Limit Signs	TC-14
Work Zone Presence Lighting	TC-19
Sequential Flashing Warning Lights	TC-22

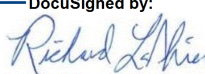
DocuSigned by:

CAF5DBC928F4E2...

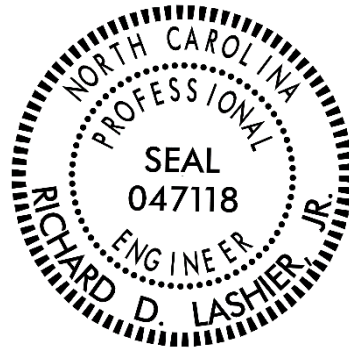
11/3/2023 | 10:32:11 AM EDT



TC-2

HI-0016
HI-0017

Robeson and Columbus Counties

WORK ZONE TRAFFIC CONTROL FOR INTERSTATE/FREEWAY RESURFACING (02/17/2020) (Rev. 5/10/2021)

General Requirements

This Provision is intended for interstate / freeway resurfacing projects. In the event, the day and time restrictions allow for daytime work activities the Work Zone Presence Lighting and Sequential Flashing Lights are to be omitted. However, the Digital Speed Limit Signs and Connected Lane Closure Devices will be required as described below.

Maintain traffic in accordance with Divisions 10, 11 and 12 of the *2018 NCDOT Standard Specifications* and the following provisions:

Install Work Zone Advance Warning Signs in accordance with the attached drawing prior to beginning any other work.

When personnel and/or equipment are working on the shoulder adjacent to a divided facility and within 10 feet of an open travel lane, close the nearest open travel lane using Standard Drawing No. 1101.02 of the *2018 NCDOT Roadway Standard Drawings*.

When personnel and/or equipment are working within a lane of travel of a divided facility, close the lane using Standard Drawing No. 1101.02 of the *2018 NCDOT Roadway Standard Drawings* or as directed by the Engineer. Conduct the work so that all personnel and/or equipment remain within the closed travel lane. Perform work only when weather and visibility conditions allow safe operations as directed by the Engineer.

1. Time Restrictions for Lane Closure and Road Closure Activities

All lane closure and road closure activities shall be performed in compliance with the day and time restrictions listed and defined in this Contract.

Any activities performed outside of these requirements will be subject to the liquidated damages unless approved by the Engineer prior to beginning the activity.

The Contractor may place/pre-stage all required signs and traffic control devices necessary for lane closures prior to the closure time as approved by the Engineer. However, flashing arrow boards and changeable message signs shall not indicate lane closure information until 30 minutes or less prior to the installation of the lane closure. Typical pre-staging times are 1 hour for a single lane closure and 2 hours for double and triple lane closures. The travel lane(s) are to be closed at the prescribed times defined in this Contract. When available, law enforcement should be onsite to shadow workers during pre-staging activities.

TC-3

HI-0016
HI-0017

Robeson and Columbus Counties

For removal, the lane(s) must be reopened in compliance with the times defined in this Contract. It is acceptable to remove the signs and traffic control devices from the shoulder/staging area after the lane(s) are reopened to traffic. All electronic lane closure messages and flashing arrow displays shall be off once lanes are opened. When available, law enforcement should remain on the project while workers removed and secure their signs and devices.

2. Work Zone Speed Limits and Digital Speed Limit Signs (DSLSS)

All speed limits are the sole authority of the NCDOT. An ordinance by the State Traffic Engineer is required for all speed limits in order to have a lawfully enforceable speed limit. No speed limit messages/signs shall be installed prior to receiving a signed ordinance.

The Regional Traffic Engineering Office and the Division Construction Engineer in coordination with the Work Zone Traffic Control Section will provide all work zone speed limit recommendations based on activities and conditions.

When lane closures are in effect, implement a Work Zone Variable Speed Limit Reduction as stated in the ordinance and in accordance with the attached provision and drawing.

Use Digital Speed Limit Signs (DSLSS) to display the work zone speed limit as shown in the attached special provision and drawing. The speed limit shall be continuously displayed on the digital speed limit signs.

The Contractor will be responsible for coordinating with the Engineer when the work zone speed limits are to be changed and will have to seek approval by the Engineer before the speed limit is changed.

When the variable speed limit reductions are in effect, cover or remove any existing speed limit signs located within the active work area that conflict with the variable speed limit reduction.

The speed limit shall be returned to the existing speed limit when the lane closure is removed and traffic is returned to the existing pattern.

3. Connected Lane Closure Devices

Furnish and install Connected Lane Closure Devices that transmit the location of the lane closure to navigational companies and the Statewide Traffic Operations Center (STOC).

4. Work Zone Presence Lighting and Sequential Flashing Warning Lights

TC-4

HI-0016
HI-0017

Robeson and Columbus Counties

Provide the following for nighttime work activities in accordance with attached drawing and special provisions:

A. Furnish and install Work Zone Presence Lighting to supplement the Contractor's portable construction and equipment lighting for the purpose of alerting motorist to the existence of an active work zone and to encourage compliance with the reduced work zone speed limit. See attached special provision.

B. Furnish and install Sequential Flashing Warning Lights on drums used for merging tapers to assist motorist in determining which direction to merge and to decrease late lane merging. See attached special provision.

5. Law Enforcement

This Contract requires law enforcement presence for all lane closures or as determined by the Engineer. The Contractor will not be responsible for the payment of law enforcement officers but shall notify the Engineer 14 days in advance of any planned lane closure.

The Resident Engineer assigned to this project will notify the law enforcement agency when their presence is needed on the project. The Contractor shall cooperate with the law enforcement officers during the life of this project.

Temporary Traffic Control (TTC)

Refer to Standard Drawing No. 1101.02, 1101.11, 1110.01, 1110.02, 1115.01, 1130.01, 1135.01, 1165.01, and 1180.01 of the *2018 NCDOT Roadway Standard Drawings* when closing a lane of travel in a stationary work zone for items such as milling, paving, diamond grinding concrete pavements, minor bridge operations, and approach slab rehabilitation.

Refer to Standard Drawing No. 1101.03, Sheet 9 of 9 of the *2018 NCDOT Roadway Standard Drawings* when closing both lanes of travel in a stationary work zone for items such as bridge operations that require structure entirely closed to traffic. Lane closure durations shall be limited as described in Intermediate Contract Time No. 3.

Drums are recommended for all lane closure operations occurring at night. However, if skinny drums are used at night, they shall be placed every 20' in the tangent sections of lane closure operations. Skinny drums shall not be used for upstream tapers.

When covering work zone signs, use an opaque material that prevents reading of the sign at night by a driver using high beam headlights. Use material which does not damage the sign sheeting.

TC-5

HI-0016
HI-0017

Robeson and Columbus Counties

Refer to Roadway Standard Drawing No. 1101.02, sheets 9 and 10, of the *2018 NCDOT Roadway Standard Drawings* for diamond grinding, milling and/or paving of ramps unless otherwise approved to be closed by the Engineer. If approved, see attached drawing for typical placement of devices and signing for the detour route. All items shall be compensated for based on the unit bid price for the respective item.

Refer to Roadway Standard Drawing No. 1101.03, sheet 7, of the *2018 NCDOT Roadway Standard Drawings* for a closure of the interstate/freeway with traffic detoured via interchange ramps for items such as minor bridge and approach slab rehabilitation. Use Flaggers or Law Enforcement to direct traffic at ramp terminals as directed by the Engineer.

Refer to Roadway Standard Drawing No. 1101.02, sheet 12 or 13, of the *2018 NCDOT Roadway Standard Drawings* for utilizing a moving operation for such items as pavement marking and marker placement. A minimum speed of 3 mph shall be maintained at all times with no stops that narrow or close a lane of travel. If the moving operation is progressing slower than 3 mph at any time, install a lane closure. All traffic control devices for this operation are considered incidental to the pay items for pavement markings and markers.

Traffic Operations

1. Project Requirements

Failure to comply with the following requirements will result in a suspension of all other operations:

- A. Before working on ANY MAP, the Contractor shall submit a written construction sequence for traffic control and construction lighting for ALL MAPS to the Engineer at the first pre-construction meeting and the sequence must be approved before closing a lane of traffic.
- B. The standard active work area is 2 miles. This is defined as the distance of Resurfacing Operations taking place in a single work period. However, the maximum allowed lane closure distance is 5 miles. Approval by the Engineer is required before closing more than 2 miles of Interstate to ensure the Contractor has the equipment and labor force to actively pursue the work.
- C. Notify the Engineer 15 consecutive calendar days before resurfacing a bridge or its approaches. Patch and make repairs to bridge surface and its approaches before resurfacing occurs. Coordinate all operations on the bridge and its approaches with the Engineer.
- D. Notify the Engineer 48 hours before resurfacing the areas of existing pavement that require patching. Patch these areas before resurfacing occurs. Allow full depth asphalt patching to cool to the point of supporting traffic without displacement or rutting before reopening closed lane. Coordinate the resurfacing operations of the patched areas with the Engineer.

TC-6

HI-0016
HI-0017

Robeson and Columbus Counties

- E. Notify the Engineer 48 hours before milling or resurfacing will interfere with the existing Signal Loops. Loops may need to be placed in milled surface before resurfacing occurs. Coordinate all signal loop operations with the Engineer.
- F. Obtain written approval of the Engineer before working in more than one location or setting up additional lane closures.
- G. The Contractor on this and any adjacent projects, or subcontractors working within this project shall coordinate lane closure location, type, and direction with the Engineer to best maintain lane continuity through the limits of this and adjacent projects.
- H. Operate equipment and conduct operations in the same direction as the flow of traffic. Maintain vehicular access in accordance with Article 1101-05 of the *2018 NCDOT Standard Specifications*.
- I. Provide appropriate construction lighting in accordance with Section 1413 of the *2018 NCDOT Standard Specifications*.
- J. Contractor shall diamond grind, mill, and pave lanes in an order such that water shall not accumulate.

2. Paving Lift Requirements and Time Limitations

Failure to comply with the following requirements will result in a suspension of all other operations until all lanes of traffic are brought to the same station and elevation:

Paving Overlays and Lifts up to 3"

- A. For surface course paving lifts of 2.0" or less, the Contractor shall conduct his paving operations such that the following conditions are met.

Once paving begins in any lane, the Contractor will be permitted to pave as far as the work operations allow (up to 5 miles) for the initial paving period. In the next days' paving operation, not to exceed 72 hours, bring the adjacent lane to the same station and elevation. At the end of the work period, any uneven lane conditions shall be signed with an "UNEVEN PAVEMENT/NEXT XX MILES" on the portable changeable message signs and portable "UNEVEN PAVEMENT" signs (dual mounted) 1,000' in advance of the uneven pavement and every ½ miles thereafter along the uneven portion of roadway. Once mitigated, all portable "UNEVEN PAVEMENT" signs shall be removed.

For Open Graded Surface Mixes, "UNEVEN PAVEMENT" signs are not required.

TC-7

HI-0016
HI-0017

Robeson and Columbus Counties

- B. For 3” surface course mixes, place in two paving lifts of 1 ½” each unless directed otherwise by the Engineer. Conditions for uneven travel lanes same as described above.

Paving Lifts Greater than 3”

For all other paving lifts greater than 3”, bring all newly resurfaced lanes to the same station and elevation by the end of each work period unless the Contractor utilizes the notched wedge paving methods as described below:

- A. Any paving lift greater than 3” shall be mitigated by having an approved wedge apparatus on the paver that shapes the edge 1” vertically and the remaining at a maximum slope steepness of 2:1. The maximum paving lift allowed to use this method is 3”.
- B. At the end of the work period, the Contractor shall place portable “UNEVEN PAVEMENT” signs in advance of the uneven pavement and spaced every ½ mile along the section of uneven pavement. Once mitigated, all portable “UNEVEN PAVEMENT” signs shall be removed.
- C. In the next day’s paving operation and not to exceed 72 hours, the Contractor shall bring up the adjacent lane to the same station and elevation before any further paving takes place on the project.

Milling Operations (Does Not Apply to Fine Milling)

Conduct milling operations so that any milled pavement is paved back by the end of each work period.

A milled/grooved surface shall not be re-opened to traffic except in cases where inclement weather or mechanical failure prevents the paving back of the lane by the end of the work period.

If milled areas are not paved back within the same work period due to inclement weather or mechanical failure, the Contractor is to furnish and install portable signs to warn drivers of the conditions. The signs include “Grooved Pavement” (W8-15) w/ Motorcycle Plaque mounted below, and “Uneven Lanes” (W8-11). These are to be dual indicated where lateral clearance can be obtained within the median areas. Install the “Grooved Pavement” (W8-15) w/ Motorcycle Plaque 1500’ in advance of the milled area. Install the “Uneven Lanes” (W8-11) 500’ in advance of the milled area. Alternate these signs every ½ mile. Once mitigated, all portable signs are to be removed.

Slope the pavement at the beginning and ending of the daily milling operation as directed by the Engineer. Sweep and remove all milled material from the roadway as soon as the daily milling operation is completed. Remove any existing pavement adjacent to the milled area that has been damaged and replace with patch material as directed by the Engineer.

TC-8

HI-0016
HI-0017

Robeson and Columbus Counties

Fine Milling / Microsurfacing Operations (Depths less than 1")

For fine milling operations less than 1", paving is not required in the same work period. The paving of the fine milled area is to be conducted within the next work period and not to exceed 72 hours. No advance warning signs are needed for the conditions. However, pavement markings are required by the end of each work period.

3. Temporary Pavement Markings

Review and record the existing pavement markings and markers before obliteration. Re-establish the new pavement markings and markers using the record of existing markings in conjunction with the *2018 NCDOT Roadway Standard Drawings* unless otherwise directed by the Engineer. Submit the record of the existing pavement markings seven calendar days before the obliteration of any pavement markings.

Obliterated pavement markings shall be replaced by the end of each work period. Interim paint may be used to comply with time limitations if final pavement markings cannot be placed except for milled surfaces or diamond ground surfaces. Final markings shall be placed within 30 days in accordance with Section 1205-4 and Section 1205-5. For milled surfaces, temporary pavement markings shall be used in accordance with Section 1205-8(C). There will be no direct payment for interim paint. Temporary paint will be paid for at the contract unit price.

For concrete surfaces that have been diamond ground as a surface treatment, 4" temporary paint shall be used in accordance with Section 1205-8(C). Upon completion of all diamond grinding operations, 4" line removal shall be used to remove 100% of the 4" temporary paint on the final concrete surface by grinding method only. Use an acceptable method to grind ridges smooth only where pavement markings will be installed prior to placing final pavement marking material. This method shall also be used in the area of the black contrast for surface preparation. Payment for line removal will be made in accordance with Section 1205-10.

For project winterization, install temporary paint markings in accordance with Section 1205-8(C) of the *2018 NCDOT Standard Specifications*. Use 4" lane, edge, and center lines and 8" gore lines. Compensation for this work shall be made in accordance with Section 1205-10 except that no payment will be made if paving is completed more than 30 days before the written notification by the Department that winterization is required.

4. Work Zone Signing:

A. Description

TC-9

HI-0016
HI-0017

Robeson and Columbus Counties

Install advance/general warning work zone signs according to the attached drawings prior to beginning work.

For paving overlays of 3” or greater that create a drop-off adjacent to the median shoulder, install “LOW/SOFT SHOULDER” (SP 13107) signs on the median shoulder. Place initially at the construction limits, and then space 1 mile thereafter. No signing required for the outside shoulder.

Install and maintain signing in accordance with the Divisions 11 and 12 of the *2018 NCDOT Standard Specifications*.

B. Installation

All stationary Work Zone Advance/General Warning signs require notification to existing Utility owners per Article 105-8 of the 2018 Standard Specifications and Special Provision SP1 G115 within 3 to 12 full working days prior to installation.

Install all Work Zone Advance/General Warning signs before beginning work on a particular map. If signs are installed more than seven (7) calendar days prior to the beginning of work on a particular map, cover the signs until the work begins. Install each Work Zone Advance/General Warning sign separately and not on the same post or stand with any other sign except where an advisory speed plate or directional arrow is used.

All sign locations to be verified by the Engineer prior to installation. Once the signs have been installed and accepted, any sign relocations requested by the Department will be compensated in accordance with Article 104-7. Any additional signs other than the ones required in this provision or attached drawings will be compensated in accordance with Article 104-7.

If there is a period of construction inactivity longer than 14 calendar days, remove or cover Work Zone Advance/General Warning signs. Uncover Work Zone Advance/General Warning signs no more than 7 calendar days before work resumes.

All other operations may be suspended upon failure to comply with the above requirements. Such suspended operations would not be resumed until the above requirements are fulfilled.

C. Sign Removal

Once Maps on the project are substantially completed, it is acceptable to remove the stationary work zone signs on those Maps in lieu of waiting until all of the Maps are

TC-10

HI-0016
HI-0017

Robeson and Columbus Counties

completed on the project. A Map is substantially complete when the resurfacing operations are completed and the shoulders are brought up to the same elevation as the proposed pavement and when temporary pavement markings (paint) are installed along the centerline and edge lines as well as the ramps and loops. The final pavement markings (thermoplastic or polyurea) and/or markers do not have to be installed for the Map to be considered substantially complete. Final pavement markings and markers are installed with portable signing and changeable message signs according to Roadway Standard Drawing 1101.02, sheet 13. Any remaining punch list items requiring traffic control are to be completed using portable work zone signing with compensation covered in the contract unit price for the required traffic control items.

Stationary Work Zone Sign removal is a condition of final project acceptance.

D. Lane Closure Work Zone Signs

Install any required lane closure signing needed during the life of the project in accordance with the Standard Drawing No. 1101.02, 1101.11 and 1110.02 of the *2018 NCDOT Roadway Standard Drawings*.

Measurement and Payment

The lane closure distance is measured from the end of the merge taper where traffic is completely in the remaining open lane(s) to the last channelizing device closing the lane. For multiple lane closures, the lane closure distance is measured from the end of the last merge taper to the last channelizing device closing the lane.

Work Zone Signs (Stationary) will be measured and paid as the actual number of square feet satisfactorily installed at each location and accepted by the Engineer.

Single Lane Closure will be measured and paid as the actual number of single stationary lane closures satisfactorily installed for required operations as shown in Roadway Standard Drawing 1101.02, sheets 4, 5, 6, 9 & 10. All labor, traffic control devices, and signing for *Single Lane Closure*, up to 2 miles, as shown in these Roadway Standard Drawings are paid under this item

Double Lane Closure will be measured and paid as the actual number of double stationary lane closures satisfactorily installed for paving and all other required operations as shown in Roadway Standard Drawing 1101.02, sheet 8, 9 & 10, or 1101.03 Sheet 9. All labor, traffic control devices, and signing for *Double Lane Closure*, as shown in these Roadway Standard Drawings are paid under this item. In the event, separate double lane closures are necessary in the same direction as the work operation and the closures are at least 2 miles apart, the Contractor will be paid for each double lane closure.

TC-11

HI-0016
HI-0017

Robeson and Columbus Counties

Triple Lane Closure will be measured and paid as the actual number of triple stationary lane closures satisfactorily installed for paving and all other required operations as shown in Roadway Standard Drawing 1101.02, sheet 8, plus the addition of another lane closure, and sheets 9 & 10. All labor, traffic control devices, and signing for *Triple Lane Closure* as defined above are paid under this item. In the event, separate triple lane closures are necessary in the same direction as the work operation and the closures are at least 2 miles apart, the Contractor will be paid for each triple lane closure.

Ramp/Loop Traffic Control will be measured and paid as the actual number of traffic control set ups satisfactorily installed at each ramp and loop as shown in Roadway Standard Drawing 1101.02, sheets 9 and 10, for paving and all other required operations. This includes set ups on multiple lane ramps and loops. All labor, traffic control devices, and signing for *Ramp/Loop Traffic Control* as shown in these Roadway Standard Drawings are paid under this item.

Ramp/Loop Closure will be measured and paid as the actual number of total ramp/loop closures and detours satisfactorily installed for ramp/loop paving and all other required operations, as shown on the Short Term Closure and Detour of Interstate/Freeway Ramps detail drawing. All labor, traffic control devices and signing required for re-routing traffic as shown on the Short Term Closure and Detour of Interstate/Freeway Ramps detail drawing are paid under this item. In the event two separate ramps are closed at the same time, they will be measured individually and paid on a per each basis.

Paint Pavement Marking Lines, Paint Pavement Marking Symbols, and Removal of Pavement Marking Lines will be measured and paid in accordance with Section 1205-10.

Digital Speed Limit Signs, Connected Lane Closure Devices, Sequential Flashing Warning Lights, and Work Zone Presence Lighting are paid separately in accordance with their respective special provisions.

Payment will be made under:

Pay Item	Pay Unit
Work Zone Signs (Stationary)	SF
Single Lane Closure	EA
Double Lane Closure	EA
Ramp/Loop Traffic Control	EA
Ramp/Loop Closures	EA

STATIONARY ADVANCE WARNING SIGNS FOR INTERSTATE / FREEWAY RESURFACING PROJECTS

DIVIDED MEDIANS WITH WIDTHS 46' OR GREATER

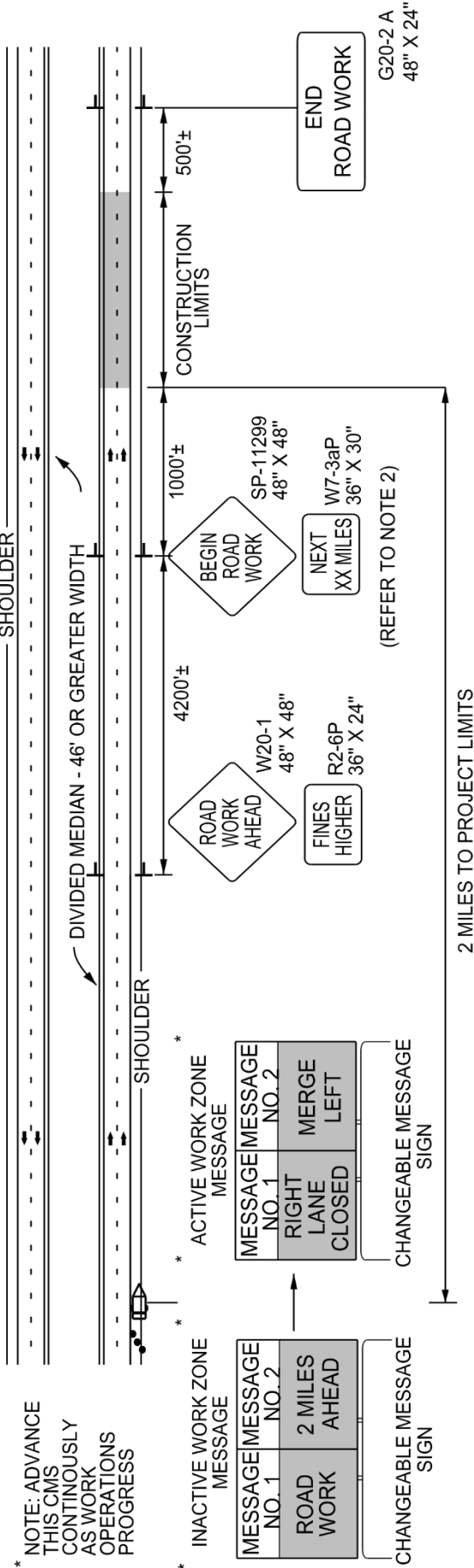

DIVIDED MEDIANS WITH WIDTHS LESS THAN 46' OR WITH PERMANENT MEDIAN BARRIER

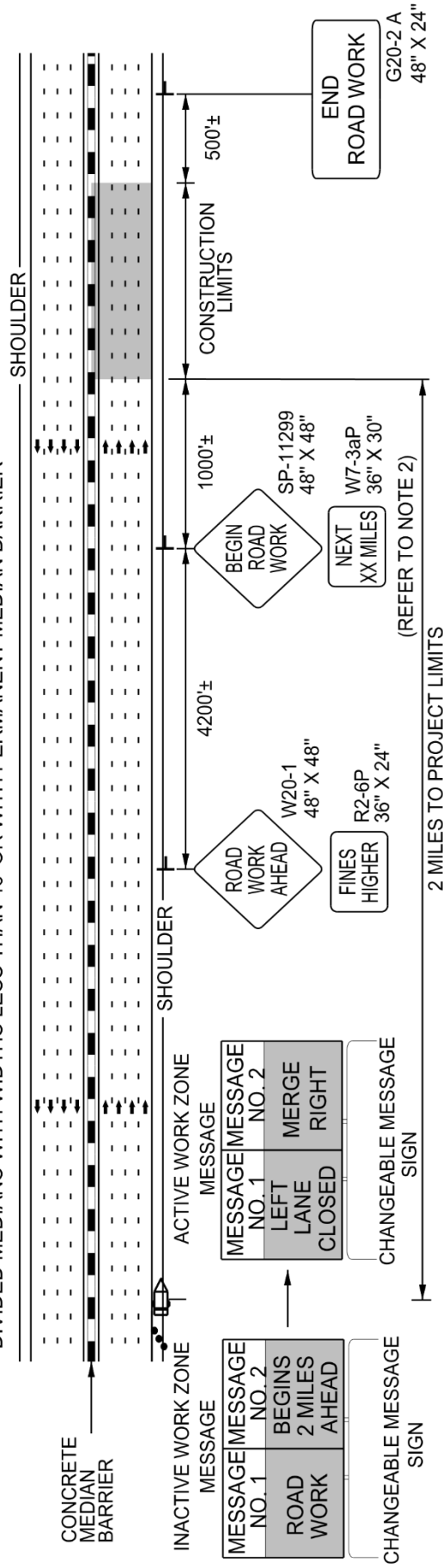

LEGEND

- ▲ DIRECTION OF TRAFFIC FLOW
 - TRAFFIC DRUM
 - ◁ CHANGEABLE MESSAGE SIGN (CMS)
 - ▬ STATIONARY SIGN
- NOTES
1. THIS DRAWING IS TO BE USED IN CONJUNCTION WITH THE WORK ZONE VARIABLE SPEED LIMIT USING DIGITAL SPEED LIMIT SIGNS FOR INTERSTATE/FREEWAY RESURFACING PROJECTS DETAIL.
 2. FOR SIGN W7-3aP, ROUND TO THE NEAREST MILE.
 3. FOR ENTRANCE AND EXIT RAMP, REFER TO RSD 1101.01, SHEET 1, DETAIL B & C.
 4. FOR ADDITIONAL NOTES, REFER TO RSD 1101.01, SHEET 1.

TYPICAL RAMP DETOURS

SHORT TERM CLOSURE AND DETOUR OF OFF-RAMP TO ADJACENT INTERCHANGE

USE IN CONJUNCTION WITH RSD 1101.02, SHEET 3 OR 4.

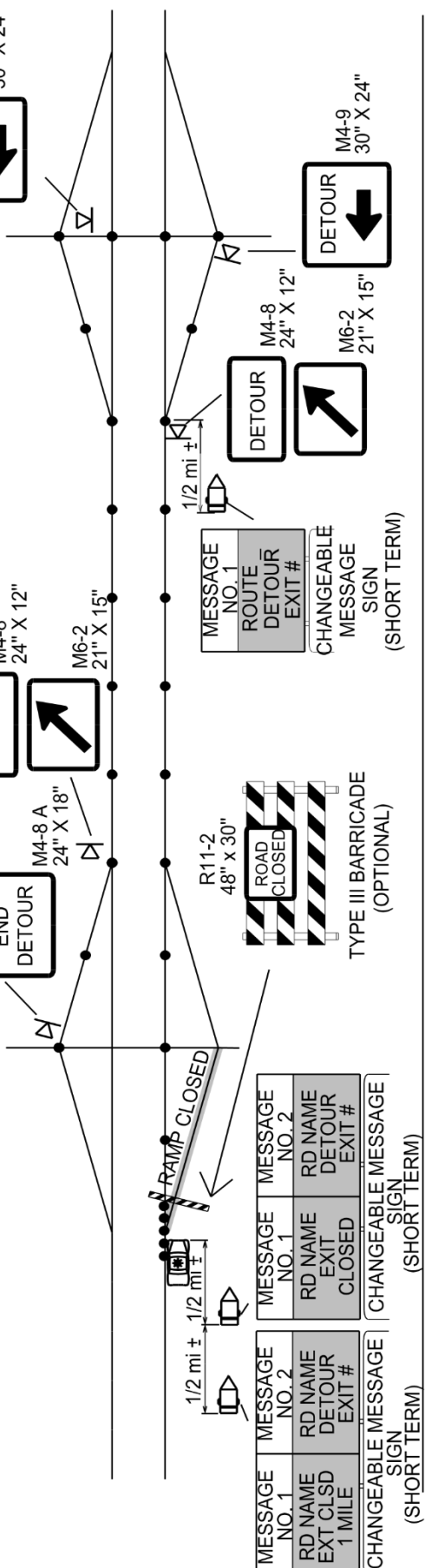

SHORT TERM CLOSURE AND DETOUR OF ON-RAMP TO ADJACENT INTERCHANGE

USE IN CONJUNCTION WITH RSD 1101.02, SHEET 3 OR 4.

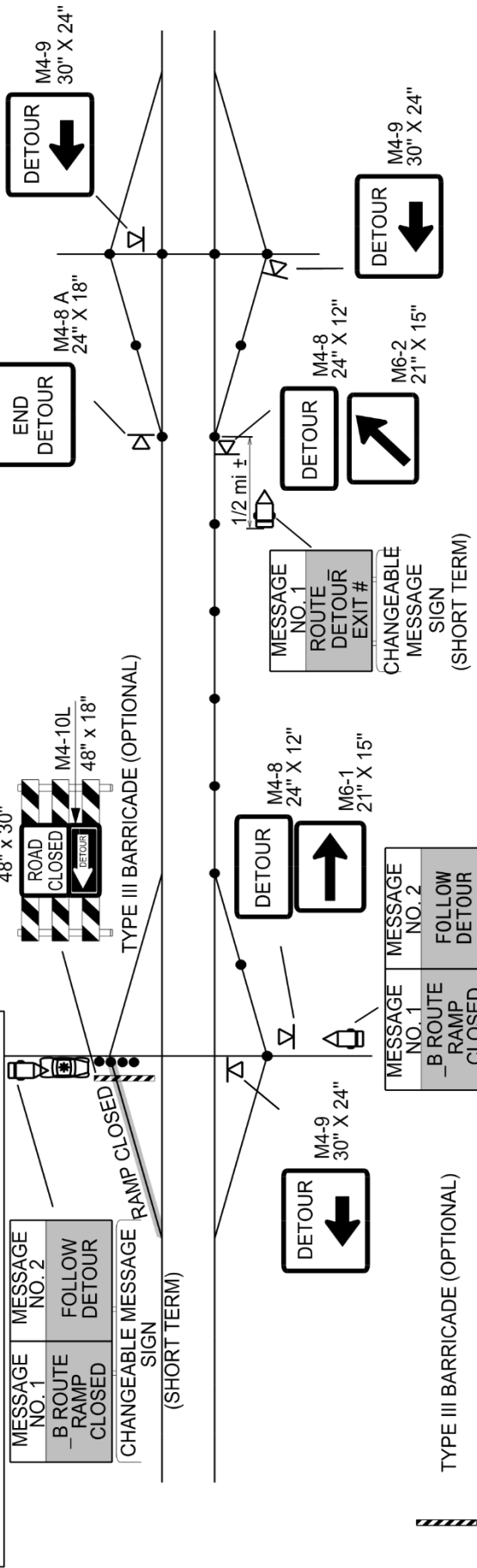

- GENERAL NOTES**
1. THIS DRAWING IS INTENDED FOR USE DURING SHORT TERM CLOSURES OF INTERSTATE AND FREEWAY RAMP.
 2. RAMP CLOSURES SHALL BE APPROVED BY THE ENGINEER.
 3. IF RAMP CLOSURE RESTRICTIONS APPLY, SEE SPECIAL PROVISION, "INTERMEDIATE CONTRACT TIMES AND LIQUIDATED DAMAGES".
- GENERAL NOTES**
- DRUM
 - ☠ LAW ENFORCEMENT
 - DETOUR ROUTE

TC-14

HI-0016
HI-0017

Robeson and Columbus Counties

WORK ZONE DIGITAL SPEED LIMIT SIGNS

(5/10/2021)

Description

Furnish and install Work Zone Digital Speed Limit Signs on interstates and freeways with speed limits of 55 mph or greater. These signs are regulatory speed limit signs with LED displays for the speed limit numbers.

Materials

Digital Speed Limit Signs shall be a minimum 36" wide x 48" high. The speed limit sign (R2-1) shall be black on white with high intensity white prismatic sheeting.

The Digital Speed Limit Sign shall be mounted such that the bottom of the sign is 7' above roadway.

The LED panel shall be a minimum of 28" wide x 18" high. The display on the LED panel shall be amber or white.

The LED numbers shall have a minimum 5 wide by 7 high pixel array with a minimum height of 18".

The LED panel shall have auto brightness/dimming capability.

The black on orange "WORK ZONE" sign shall be mounted above the speed limit sign. It shall be 36" wide x 24" high with high intensity prismatic orange sheeting.

The black on white "\$250 FINE" sign shall be mounted below the speed limit sign. It shall be 36" wide x 24" high with high intensity prismatic white sheeting.

All digital speed limit systems shall have operational software and wireless communications that allows for remote operation and data monitoring. It shall be configured to allow access by the Engineer or their designee to change each sign independently or change the speed limit on all signs at once from a PC, tablet or cellular phone application.

Radar equipment to detect approaching speeds on the digital speed limit systems is optional. However, if the systems have radar, they will be equipped to store the detected speed data, this information should be available in a spreadsheet format and accessed remotely from a secure cloud location.

The Work Zone Digital Speed Limit systems shall have flashing beacons. The beacons are to be a minimum of 8" diameter LED circular yellow. They shall be mounted above and below the sign assemblies and are to be centered. The beacons shall alternately flash at rates not less than 50 or more than 60 times per minute.

TC-15

HI-0016
HI-0017

Robeson and Columbus Counties

In addition, the flashing beacons shall be mounted in such a manner that the \$250 FINE sign is not obscured when in operation.

Digital Speed Limit Signs may be trailer mounted or stationary mounted. The unit shall be solar powered and have the ability to operate continuously. It shall be supplemented with a battery backup system which includes a 110/120 VAC powered on-board charging system.

The batteries, when fully charged, shall be capable of powering the display for 20 continuous days with no solar power. The unit shall be capable of being powered by standard 110/120 VAC power source.

Store the battery bank and charging system in a lockable, weather and vandal resistant box.

All Work Zone Digital Speed Limit Sign equipment shall be on the NCDOT Approved Products List.

Digital Speed Limit Displays

The speed limit shall be continuously displayed on the signs. All other stationary speed limit signs shall be covered when Digital Speed Limit systems are in operation.

Reduced Speed Limit Displays

The Digital Speed Limit systems shall have beacons activated when the work zone speed limit is reduced. Otherwise, the beacons are to remain off.

IF THE DIGITAL SPEED LIMIT SYSTEM IS EQUIPPED WITH RADAR: The Digital Speed Limit Signs shall display the reduced work zone speed limit without flashing the LED speed limit number unless approaching speeds are detected to be 6 MPH or higher than the displayed speed limit. If speeds are detected 6 MPH or above the displayed Speed Limit, then the LED shall flash the speed limit until the speeds are within the 6 MPH tolerance.

Existing Speed Limit Displays

When the existing speed limit is displayed on the Digital Speed Limit Signs, the beacons are to remain off.

IF THE DIGITAL SPEED LIMIT SYSTEM IS EQUIPPED WITH RADAR: The speed limit number is not to flash unless the approaching speeds are detected to be 6 MPH or higher than the displayed speed limit.

Other Construction Methods

TC-16

HI-0016
HI-0017

Robeson and Columbus Counties

The speed limits are the sole authority of the NCDOT. An ordinance by the State Traffic Engineer is required for all speed limits in order to have a lawfully enforceable speed limit.

The Regional Traffic Engineering Office and the Division Construction Engineer in coordination with the Work Zone Traffic Control Section will provide all work zone speed limit recommendations based on activities and conditions.

The Contractor will be responsible for coordinating with the Engineer when the work zone speed limits are to be changed and will have to seek approval by the Engineer or their designee before the speed limit is changed.

Whenever possible, each trailer mounted unit shall be placed on the paved shoulder and shall have the capability of being leveled.

Measurement and Payment

Work Zone Digital Speed Limit Signs will be measured and paid as the maximum number of Work Zone Digital Speed Limit Signs satisfactorily installed according to the attached detail and properly functioning at any one time during the life of the project.

This includes all materials and labor to install, maintain and remove all the Work Zone Digital Speed Limit Signs.

Pay Item

Work Zone Digital Speed Limit Signs

Pay Unit

Each

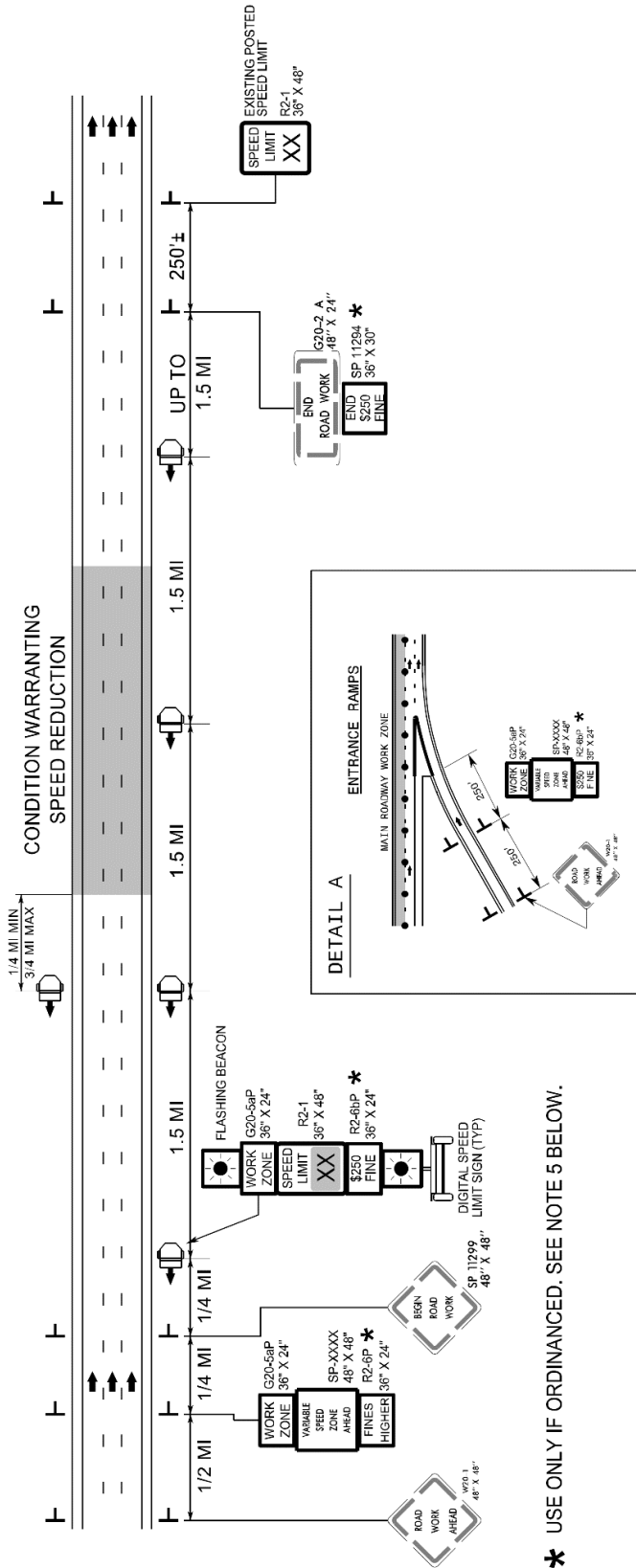

*** USE ONLY IF ORDINANCED. SEE NOTE 5 BELOW.**

NOTES

1. THE DIGITAL SPEED LIMIT SIGNS WILL BE INSTALLED (TRAILER MOUNTED OR STATIONARY MOUNTED) IN ADVANCE OF AND SPACED APPROXIMATELY 1.5 MILES THROUGHOUT THE PROJECT LIMITS, UNLESS DIRECTED OTHERWISE.
2. WITHIN 1/4 TO 3/4 MILE UPSTREAM OF CONDITION WARRANTING A SPEED REDUCTION, PLACE A DIGITAL SPEED LIMIT SIGN ON BOTH THE INSIDE AND OUTSIDE SHOULDERS, UNLESS DIRECTED OTHERWISE BY THE ENGINEER. AT ALL OTHER LOCATIONS DOWNSTREAM, PLACE A SINGLE DIGITAL SPEED LIMIT SIGN ON THE OUTSIDE SHOULDER.
IF SIGNS ARE NOT HIGHLY VISIBLE TO ALL MOTORISTS, SUPPLEMENTAL DIGITAL SPEED LIMIT SIGNS ARE PERMITTED ON THE MEDIAN SHOULDER.
3. THE DIGITAL SPEED LIMIT SIGNS TAKE PRECEDENCE OVER EXISTING SPEED LIMIT SIGNS AND SHOULD REMAIN UPRIGHT AND VISIBLE AT ALL TIMES. ALL EXISTING SPEED LIMIT SIGNS SHALL BE COVERED OR REMOVED FOR DURATION OF THE PROJECT.
4. NCDOT HAS SOLE AUTHORITY OF THE SPEED LIMITS DISPLAYED ON THE DIGITAL SPEED LIMIT SIGNS.
5. THE WORK ZONE VARIABLE SPEED LIMIT AND THE \$250 SPEEDING PENALTY ARE SEPARATE ORDINANCES THAT MUST BE SIGNED BY THE STATE TRAFFIC ENGINEER TO BE VALID AND ENFORCEABLE. WITHOUT SIGNED ORDINANCES, THE SPEED LIMIT ON A FACILITY SHALL REMAIN UNCHANGED AND/OR HIGHER FINES SIGNS SHALL NOT BE USED.
6. THE REDUCED SPEED SHALL BE DISPLAYED A MINIMUM OF 1/4 MILE AND A MAXIMUM OF 3/4 MILE IN ADVANCE OF AND THROUGHOUT THE AREA MEETING CONDITIONS LISTED IN THE CHART. THE EXISTING SPEED LIMIT SHALL BE DISPLAYED ON ALL OTHER DIGITAL SPEED LIMIT SIGNS.
7. THE SPEED DISPLAYED SHALL BE THE LOWER OF THE EXISTING SPEED LIMIT OR THE SPEED IN THE WORK ZONE CONDITION CHART.
8. THE BEACONS ON THE DIGITAL SPEED LIMIT SIGNS SHALL ONLY FLASH DURING TIMES THE SPEED IS REDUCED, AND REMAIN OFF AT ALL OTHER TIMES.

WORK ZONE CONDITIONS	SPEED TO DISPLAY (SEE NOTE 6 & 7)
2 LANES REDUCED TO 1 LANE	55
3 LANES REDUCED TO 1 LANE	55
3 LANES REDUCED TO 2 LANES	60
4 LANES REDUCED TO 1 LANE	55
4 LANES REDUCED TO 2 LANES	60
4 LANES REDUCED TO 3 LANES	65
1 OPEN LANE WITH CONTINUOUS BARRIER ON BOTH SHOULDERS	55
1 OPEN LANE WITH CONTINUOUS BARRIER ON 1 SHOULDER	60
3 OR 2 OPEN LANES WITH CONTINUOUS BARRIER ON BOTH SHOULDERS	60
3 OR 2 OPEN LANES WITH CONTINUOUS BARRIER ON 1 SHOULDER	65
4 OPEN LANES WITH BARRIER CONTINUOUS ON BOTH SHOULDERS	65
4 OPEN LANES WITH BARRIER CONTINUOUS ON 1 SHOULDER	EXISTING
UNEVEN LANES	60

LANE CLOSURES

CONTINUOUS BARRIER (LENGTH OF BARRIER GREATER THAN 1 MILE)

HI-0016
HI 0017

DESIGN BY: J. Navarrete
PROJECT ID:

CHECKED BY:
LOCATION:

May 13, 2019
DIV: DIV

BORDER
R=1.5"
TH=0.63"
IN=0.47"

5.25"
6"D
4.5"
6"D
4.5"
6"D
4.5"
6"D
5.25"

4'-0"
4'-0"
5.4"
37.3"
5.3"

SIGN NUMBER: WZTC
TYPE: STATIONARY
QUANTITY: SEE PLANS

BACKG COLOR: Fluorescent Orange
COPY COLOR: Black

SYMBOL	X	Y	WID	HT

SIGN WIDTH: 4'-0"
HEIGHT: 4'-0"
TOTAL AREA: 16.0 Sq.Ft.

BORDER TYPE: INSET
RECESS: 0.47"
WIDTH: 0.63"
RADI: 1.5"

NO. Z BARS: 2
LENGTH: 40.0

MAT'L: 0.080" (2.0 mm) ALUMINUM

USE NOTES: 1,2

- Legend and border shall be direct applied black non-reflective sheeting.
- Background shall be NC GRADE B fluorescent orange retroreflective sheeting.

Spacing Factor is 1 unless specified otherwise

LETTER POSITIONS

Letter spacings are to start of next letter

Letter	V	A	R	I	A	B	L	E	Series/Size
5.4	4.9	6	5.1	1.9	6	5.1	4.6	3.7	D 2000
12.2	5.1	5	4.7	4.7	4.1	12.1			D 2000
14.2	5	5.6	5.5	3.7	14				D 2000
11.2	6	5.5	4.2	6	4.1	11			D 2000
									25.8

FILENAME: Special Signs 7

NORTH CAROLINA D.O.T. SIGN DETAIL

TC-19

HI-0016
HI-0017

Robeson and Columbus Counties

WORK ZONE PRESENCE LIGHTING

(10/14/19) (Rev. 5/10/2021)

Description

Furnish and install Work Zone Presence Lighting during nightly lane closures on multilane roadways with speed limits of 55 mph or greater.

Materials

Anti-glare lighting systems are required. Work Zone Presence Lighting shall be installed in accordance with the attached detail and the Manufacturer's recommendations.

Supply a power source for each light to provide the light output as described in the chart below.

Each light unit shall be capable of providing a minimum of 14,000 lumens illuminating a minimum area of approximately 3,000 square feet. The light shall be capable of being elevated to a height of 14 feet above the pavement.

Each light unit support base or mounting stand shall have the capability of being leveled such that the light mast is plumb.

Provide Work Zone Presence Lighting listed on the NCDOT Approved Products List.

Construction Methods

Work Zone Presence Lighting is permitted to be prestaged (up to 1 hour prior for single lane closures and up to 2 hours prior for double or triple lane closures) along with other traffic control devices or installed within 1 hour after the necessary traffic control has been installed for the lane closure(s). At the end of the work night, the Work Zone Presence Lighting shall be removed within 1 hour before or after the lane closure(s) is removed.

Whenever possible, each light unit shall be placed on the outside paved shoulder, a minimum of 4 feet from the travel lane and spaced according to the chart below based on the amount of light output for each unit.

Work Zone Presence Lighting is permitted to supplement the Portable Construction Lighting inside the lane closure. At no time shall Work Zone Presence Lighting be used in lieu of Portable Construction Lighting when required.

If there is sufficient existing overhead lighting, Work Zone Presence Lighting may be eliminated as directed by the Engineer.

Lighting Unit Installation Requirements

TC-20

HI-0016
HI-0017

Robeson and Columbus Counties

The lighting units shall be installed in advance of the lane closure as shown on the attached detail and spaced according to the chart below:

Light Output (Lumens)	Illuminated Fixture Area (Sq. Ft.)	AREA 1		AREA 2	
		# of Lights	Spacing*	# of Lights	Spacing*
14,000 - 35,000	4	6	640' (16 skips)	8	480' (12 skips)
35,001 - 59,999	5	5	800' (20 skips)	6	640' (16 skips)
60,000+	6+	4	1,000' (25 skips)	5	800' (20 skips)

*Skips refer to traditional 10' pavement marking lines with 30' gaps.

Area 1: Begins 2,640' downstream from CMS; Extends to just past 1st Lane Closure Sign

Area 2: Begins just past the 1st Lane Closure Sign; Extends to just past the last Lane Closure Sign

MEASUREMENT AND PAYMENT

Work Zone Presence Lighting will be measured and paid as the maximum number of lighting units satisfactorily placed, accepted by the Engineer, and in use at any one time during the life of the project.

Relocation, replacement, repair, removal, and maintenance of Work Zone Presence Lighting units will be incidental to the work of this section. No measurement or separate payment will be made for power generators, batteries, or other power supply devices.

Pay Item
Work Zone Presence Lighting

Pay Unit
Each

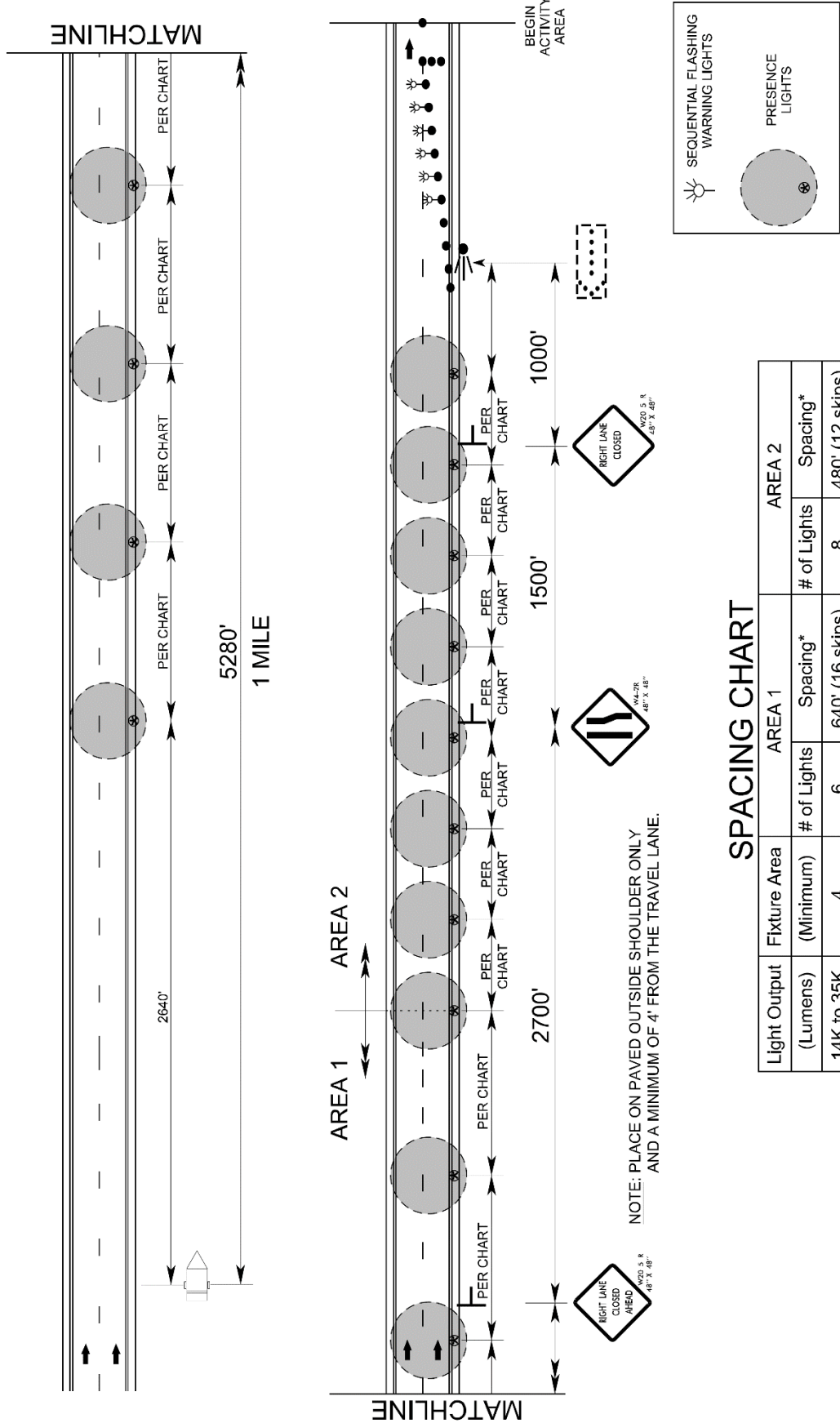

SPACING CHART

Light Output (Lumens)	AREA 1		AREA 2	
	Fixture Area (Minimum)	# of Lights	Spacing*	Spacing*
14K to 35K	4	6	640' (16 skips)	480' (12 skips)
35.1K to 60K	5	5	800' (20 skips)	640' (16 skips)
60K +	6+	4	1000' (25 skips)	800' (20 skips)

*SKIPS REFER TO TRADITIONAL 10' PAVEMENT MARKING LINES WITH 30' GAPS.

AREA 1: BEGINS 2,640' DOWNSTREAM FROM CMS; EXTENDS TO JUST PAST 1ST LANE CLOSURE SIGN

AREA 2: BEGINS JUST PAST THE 1ST LANE CLOSURE SIGN; EXTENDS TO JUST PAST THE LAST LANE CLOSURE SIGN

NOTE: PLACE ON PAVED OUTSIDE SHOULDER ONLY AND A MINIMUM OF 4' FROM THE TRAVEL LANE.

TC-22

HI-0016
HI-0017

Robeson and Columbus Counties

SEQUENTIAL FLASHING WARNING LIGHTS:

(10/08/2016)

Description

Furnish and install Sequential Flashing Warning Lights on drums used for merging tapers during nightly work activities on interstates and freeways with speed limits greater than 55 MPH and or facilities that have significant traffic volumes.

The purpose of these lights is to assist the motorist in determining which direction to merge when approaching a lane closure. It's also designed to reduce the number of late merges resulting in devices being struck and having to be reset to maintain positive guidance at the merge point. The successive flashing of the lights shall occur from the upstream end of the merging taper to the downstream end of the merging taper in order to identify the desired vehicle path.

Materials

The Sequential Flashing Warning Lights shall meet all of the requirements for warning lights within the current edition of the Manual of Uniform Traffic Control Devices (MUTCD).

Each light unit shall be capable of operating fully and continuously for a minimum of 200 hours when equipped with a standard battery set.

Each light in the sequence shall be flashed at a rate of not less than 55 times per minute and not more than 75 times per minute. The flash rate and flash duration shall be consistent throughout the sequence.

Supply a Type 3 Certification (Independent Test Lab results) documenting all actual test results for the specified parameters contained in the Institute of Transportation Engineer's (ITE's) *Purchase Specification for Flashing and Steady Burn Warning Lights*. The laboratory shall also identify all manufacturer codes and part numbers for the incandescent lamp or LED clusters, lenses, battery, and circuitry, and the total width of the light with the battery in place. The complete assembly shall be certified as crashworthy when firmly affixed to the channelizing device.

All Sequential Flashing Warning Lights shall be on the NCDOT Work Zone Traffic Control Approved Products List.

Construction Methods

Sequential Flashing Warning Lights are to be used for night time lane closures.

These lights shall flash sequentially beginning with the first light and continuing until the final light.

TC-23

HI-0016
HI-0017

Robeson and Columbus Counties

The Sequential Flashing Warning Lights shall automatically flash in sequence when placed on the drums that form the merging taper.

The number of lights used in the drum taper shall equal the number of drums used in the taper.

Drums are the only channelizing device allowed to mount sequential flashing warning lights.

The Sequential Flashing Warning Lights shall be weather independent and visual obstructions shall not interfere with the operation of the lights.

The Sequential Flashing Warning Lights shall automatically sequence when placed in line in an open area with a distance between lights of 10 to 100 feet. A 10 foot stagger in the line of lights shall have no adverse effect on the operation of the lights.

If one light fails, the flashing sequence shall continue. If more than 1 light fails, all of the lights are to be automatically turned to the "off" mode. Non-sequential flashing is prohibited.

When lane closures are not in effect, the Sequential Flashing Warning Lights shall be deactivated.

Measurement and Payment

Sequential Flashing Warning Lights will be measured and paid as the maximum number of sequential flashing warning lights satisfactorily installed and properly functioning at any one time during the life of the project.

This includes all materials and labor to install, maintain and remove all Sequential Flashing Warning Lights.

Pay Item

Sequential Flashing Warning Lights

Pay Unit

Each

STABILIZATION REQUIREMENTS:

(3-11-16) (Rev. 4-30-19)

S-2

Stabilization for this project shall comply with the time frame guidelines as specified by the NCG-010000 general construction permit effective April 1, 2019 issued by the North Carolina Department of Environmental Quality Division of Water Resources. Temporary or permanent ground cover stabilization shall occur within 7 calendar days from the last land-disturbing activity, with the following exceptions in which temporary or permanent ground cover shall be provided in 14 calendar days from the last land-disturbing activity:

- Slopes between 2:1 and 3:1, with a slope length of 10 ft. or less
- Slopes 3:1 or flatter, with a slope of length of 50 ft. or less
- Slopes 4:1 or flatter

The stabilization timeframe for High Quality Water (HQW) Zones shall be 7 calendar days with no exceptions for slope grades or lengths. High Quality Water Zones (HQW) Zones are defined by North Carolina Administrative Code 15A NCAC 04A.0105 (25). Temporary and permanent ground cover stabilization shall be achieved in accordance with the provisions in this contract and as directed.

SEEDING AND MULCHING:

(East Crimp)

The kinds of seed and fertilizer, and the rates of application of seed, fertilizer, and limestone, shall be as stated below. During periods of overlapping dates, the kind of seed to be used shall be determined. All rates are in pounds per acre.

All Roadway Areas

March 1 - August 31		September 1 - February 28	
50#	Tall Fescue	50#	Tall Fescue
10#	Centipede	10#	Centipede
25#	Bermudagrass (hulled)	35#	Bermudagrass (unhulled)
500#	Fertilizer	500#	Fertilizer
4000#	Limestone	4000#	Limestone

Waste and Borrow Locations

March 1 – August 31		September 1 - February 28	
75#	Tall Fescue	75#	Tall Fescue
25#	Bermudagrass (hulled)	35#	Bermudagrass (unhulled)
500#	Fertilizer	500#	Fertilizer
4000#	Limestone	4000#	Limestone

Note: 50# of Bahiagrass may be substituted for either Centipede or Bermudagrass only upon Engineer’s request.

Approved Tall Fescue Cultivars

06 Dust	Escalade	Justice	Scorpion
2 nd Millennium	Essential	Kalahari	Serengeti
3 rd Millennium	Evergreen 2		Shelby
Apache III	Falcon IV	Kitty Hawk 2000	Sheridan
Avenger	Falcon NG	Legitimate	Signia
Barlexas	Falcon V	Lexington	Silver Hawk
Barlexas II	Faith	LSD	Sliverstar
Bar Fa	Fat Cat	Magellan	Shenandoah Elite
Barrera	Festnova	Matador	Sidewinder
Barrington	Fidelity	Millennium SRP	Skyline
Barrobusto	Finelawn Elite	Monet	Solara
Barvado	Finelawn Xpress	Mustang 4	Southern Choice II
Biltmore	Finesse II	Ninja 2	Speedway
Bingo	Firebird	Ol' Glory	Spyder LS
Bizem	Firecracker LS	Olympic Gold	Sunset Gold
Blackwatch	Firenza	Padre	Taccoa
Blade Runner II	Five Point	Patagonia	Tanzania
Bonsai	Focus	Pedigree	Trio
Braveheart	Forte	Picasso	Tahoe II
Bravo	Garrison	Piedmont	Talladega
Bullseye	Gazelle II	Plantation	Tarheel
Cannavaro	Gold Medallion	Proseeds 5301	Terrano
Catalyst	Grande 3	Prospect	Titan Ltd
Cayenne	Greenbrooks	Pure Gold	Titanium LS
Cessane Rz	Greenkeeper	Quest	Tracer
Chipper	Gremlin	Raptor II	Traverse SRP
Cochise IV	Greystone	Rebel Exeda	Tulsa Time
Constitution	Guardian 21	Rebel Sentry	Turbo
Corgi	Guardian 41	Rebel IV	Turbo RZ
Corona	Hemi	Regiment II	Tuxedo RZ
Coyote	Honky Tonk	Regenerate	Ultimate
Darlington	Hot Rod	Rendition	Venture
Davinci	Hunter	Rhambler 2 SRP	Umbrella
Desire	Inferno	Rembrandt	Van Gogh
Dominion	Innovator	Reunion	Watchdog
Dynamic	Integrity	Riverside	Wolfpack II
Dynasty	Jaguar 3	RNP	Xtremegreen
Endeavor	Jamboree	Rocket	

On cut and fill slopes 2:1 or steeper Centipede shall be applied at the rate of 5 pounds per acre and add 20# of Sericea Lespedeza from January 1 - December 31.

Fertilizer shall be 10-20-20 analysis. A different analysis of fertilizer may be used provided the 1-2-2 ratio is maintained and the rate of application adjusted to provide the same amount of plant food as a 10-20-20 analysis and as directed.

All areas seeded and mulched shall be tacked with asphalt. Crimping of straw in lieu of asphalt tack shall not be allowed on this project.

CRIMPING STRAW MULCH:

Crimping shall be required on this project adjacent to any section of roadway where traffic is to be maintained or allowed during construction. In areas within six feet of the edge of pavement, straw is to be applied and then crimped. After the crimping operation is complete, an additional application of straw shall be applied and immediately tacked with a sufficient amount of undiluted emulsified asphalt.

Straw mulch shall be of sufficient length and quality to withstand the crimping operation.

Crimping equipment including power source shall be subject to the approval of the Engineer providing that maximum spacing of crimper blades shall not exceed 8".

WATTLE:

Description

Wattles are tubular products consisting of excelsior fibers encased in synthetic netting. Wattles are used on slopes or channels to intercept runoff and act as a velocity break. Wattles are to be placed at locations shown on the plans or as directed. Installation shall follow the detail provided in the plans and as directed. Work includes furnishing materials, installation of wattles, matting installation, and removing wattles.

Materials

Wattle shall meet the following specifications:

	100% Curled Wood (Excelsior) Fibers
Minimum Diameter	12 in.
Minimum Density	2.5 lb/ft ³ +/- 10%
Net Material	Synthetic
Net Openings	1 in. x 1 in.
Net Configuration	Totally Encased
Minimum Weight	20 lb. +/- 10% per 10 ft. length

Anchors: Stakes shall be used as anchors.

Wooden Stakes:

Provide hardwood stakes a minimum of 2-ft. long with a 2 in. x 2 in. nominal square cross section. One end of the stake must be sharpened or beveled to facilitate driving down into the underlying soil.

Matting shall meet the requirements of Article 1060-8 of the *Standard Specifications*, or shall meet specifications provided elsewhere in this contract.

Provide staples made of 0.125" diameter new steel wire formed into a *u* shape not less than 12" in length with a throat of 1" in width.

Construction Methods

Wattles shall be secured to the soil by wire staples approximately every 1 linear foot and at the end of each section of wattle. A minimum of 4 stakes shall be installed on the downstream side of the wattle with a maximum spacing of 2 linear feet along the wattle, and according to the detail. Install a minimum of 2 stakes on the upstream side of the wattle according to the detail provided in the plans. Stakes shall be driven into the ground a minimum of 10 in. with no more than 2 in. projecting from the top of the wattle. Drive stakes at an angle according to the detail provided in the plans.

Only install wattle(s) to a height in ditch so flow will not wash around wattle and scour ditch slopes and according to the detail provided in the plans and as directed. Overlap adjoining sections of wattles a minimum of 6 in.

Installation of matting shall be in accordance with the detail provided in the plans, and in accordance with Article 1631-3 of the *Standard Specifications*, or in accordance with specifications provided elsewhere in this contract.

The Contractor shall maintain the wattles until the project is accepted or until the wattles are removed, and shall remove and dispose of silt accumulations at the wattles when so directed in accordance with the requirements of Section 1630 of the *Standard Specifications*.

Measurement and Payment

Wattle will be measured and paid for by the actual number of linear feet of wattles which are installed and accepted. Such price and payment will be full compensation for all work covered by this section, including, but not limited to, furnishing all materials, labor, equipment and incidentals necessary to install the *Wattle*.

Matting will be measured and paid for in accordance with Article 1631-4 of the *Standard Specifications*, or in accordance with specifications provided elsewhere in this contract.

Payment will be made under:

Pay Item

Wattle

Pay Unit

Linear Foot

CONCRETE WASHOUT STRUCTURE:

(12-10-20)

Description

Concrete washout structures are enclosures above or below grade to contain concrete waste water and associated concrete mix from washing out ready-mix trucks, drums, pumps, or other equipment. Concrete washouts must collect and retain all the concrete washout water and solids, so that this material does not migrate to surface waters or into the ground water. These enclosures are not intended for concrete waste not associated with wash out operations.

The concrete washout structure may include constructed devices above or below ground and or commercially available devices designed specifically to capture concrete wash water.

Materials

Item

Temporary Silt Fence

Section

1605

Safety Fence shall meet the specifications as provided elsewhere in this contract.

Geomembrane basin liner shall meet the following minimum physical properties for low permeability; it shall consist of a polypropylene or polyethylene 10 mil thick geomembrane. If the minimum setback dimensions can be achieved the liner is not required. (5 feet above groundwater, 50 feet from top of bank of perennial stream, other surface water body, or wetland.)

Construction Methods

Build an enclosed earthen berm or excavate to form an enclosure in accordance with the details and as directed.

Install temporary silt fence around the perimeter of the enclosure in accordance with the details and as directed if structure is not located in an area where existing erosion and sedimentation control devices are capable to containing any loss of sediment.

Post a sign with the words “Concrete Washout” in close proximity of the concrete washout area, so it is clearly visible to site personnel. Install safety fence as directed for visibility to construction traffic.

The construction details for the above grade and below grade concrete washout structures can be found on the following web page link:

<https://connect.ncdot.gov/resources/roadside/SoilWaterDocuments/ConcreteWashoutStructuredetail.pdf>

Alternate details for accommodating concrete washout may be submitted for review and approval.

The alternate details shall include the method used to retain and dispose of the concrete waste water within the project limits and in accordance with the minimum setback requirements. (5 feet above groundwater, 50 feet from top of bank of perennial stream, other surface water body, or wetland.)

Maintenance and Removal

Maintain the concrete washout structure(s) to provide adequate holding capacity plus a minimum freeboard of 12 inches. Remove and dispose of hardened concrete and return the structure to a functional condition after reaching 75% capacity.

Inspect concrete washout structures for damage and maintain for effectiveness.

Remove the concrete washout structures and sign upon project completion. Grade the earth material to match the existing contours and permanently seed and mulch area.

Measurement and Payment

Concrete Washout Structure will be paid for per each enclosure installed in accordance with the details. If alternate details or commercially available devices are approved, then those devices will also be paid for per each approved and installed device.

Temporary Silt Fence will be measured and paid for in accordance with Article 1605-5 of the *Standard Specifications*.

Safety Fence shall be measured and paid for as provided elsewhere in this contract.

No measurement will be made for other items or for over excavation or stockpiling.

Payment will be made under:

Pay Item	Pay Unit
Concrete Washout Structure	Each

TACK FOR MULCH FOR EROSION CONTROL:
(07-19-22)

Description

This work consists of supplying and installing of an approved material for binding mulch for erosion control in accordance with Section 1060-5, Section 1615 and Section 1660 of the *Standard*

Specifications. This provision defines acceptable materials and rates for tacking material for holding mulch in place.

Materials

(a) Emulsified Asphalt

Asphalt emulsion tack shall conform to the requirements of AASHTO M 140, Specification for Emulsified Asphalt. The emulsified asphalt may be rapid setting, medium setting, or slow setting. Apply emulsified asphalt tackifier at a rate of 0.10 gallons per square yard (approximately 484 gallons per acre).

(b) Cellulose Hydromulch

Cellulose hydromulch products shall be non-toxic, weed-free, prepackaged cellulose fiber (pulp) material containing no more than 3% ash or other inert materials. Cellulose hydromulches may contain dyes or binders specifically formulated to enhance the adhesive qualities of the hydromulch. Apply cellulose hydromulches at a rate of 1000 pounds (dry weight) per acre.

Wood fiber or wood fiber blend hydromulches may be substituted for cellulose hydromulch at the same application rate.

(c) Other tackifiers

Other approved materials, specifically designed and manufactured for application as a straw mulch tacking agent, may be used at the manufacturer's recommended rate.

Construction Methods

Apply the Tack for Mulch for Erosion Control uniformly across straw mulch per Section 1615 and Section 1660 of the *Standard Specifications*.

Payment

Tack for Mulch for Erosion Control is incidental to the application of *Temporary Mulching*, Section 1615-4, and *Seeding and Mulching*, Section 1660-8, and no additional payment will be made.

RESPONSE FOR EROSION CONTROL:**Description**

Furnish the labor, materials, tools and equipment necessary to move personnel, equipment, and supplies to the project necessary for the pursuit of any or all of the following work as shown herein, by an approved subcontractor.

Section	Erosion Control Item	Unit
1605	Temporary Silt Fence	LF
1606	Special Sediment Control Fence	LF/TON
1615	Temporary Mulching	ACR
1620	Seed - Temporary Seeding	LB
1620	Fertilizer - Temporary Seeding	TN
1631	Matting for Erosion Control	SY
SP	Coir Fiber Mat	SY
1640	Coir Fiber Baffles	LF
SP	Permanent Soil Reinforcement Mat	SY
1660	Seeding and Mulching	ACR
1661	Seed - Repair Seeding	LB
1661	Fertilizer - Repair Seeding	TON
1662	Seed - Supplemental Seeding	LB
1665	Fertilizer Topdressing	TON
SP	Safety/Highly Visible Fencing	LF
SP	Response for Erosion Control	EA

Construction Methods

Provide an approved subcontractor who performs an erosion control action as described in the NPDES Inspection Form SPPP30. Each erosion control action may include one or more of the above work items.

Measurement and Payment

Response for Erosion Control will be measured and paid for by counting the actual number of times the subcontractor moves onto the project, including borrow and waste sites, and satisfactorily completes an erosion control action described in Form 1675. The provisions of Article 104-5 of the *Standard Specifications* will not apply to this item of work.

Payment will be made under:

Pay Item	Pay Unit
Response for Erosion Control	Each

SAFETY FENCE AND JURISDICTIONAL FLAGGING:

Description

Safety Fence shall consist of furnishing materials, installing and maintaining polyethylene or polypropylene fence along the outside riparian buffer, wetland, or water boundary, or other boundaries located within the construction corridor to mark the areas that have been approved to infringe within the buffer, wetland, endangered vegetation, culturally sensitive areas or water. The fence shall be installed prior to any land disturbing activities.

Interior boundaries for jurisdictional areas noted above shall be delineated by stakes and highly visible flagging.

Jurisdictional boundaries at staging areas, waste sites, or borrow pits, whether considered outside or interior boundaries shall be delineated by stakes and highly visible flagging.

Materials

(A) Safety Fencing

Polyethylene or polypropylene fence shall be a highly visible preconstructed safety fence approved by the Engineer. The fence material shall have an ultraviolet coating.

Either wood posts or steel posts may be used. Wood posts shall be hardwood with a wedge or pencil tip at one end, and shall be at least 5 ft. in length with a minimum nominal 2" x 2" cross section. Steel posts shall be at least 5 ft. in length, and have a minimum weight of 0.85 lb/ft of length.

(B) Boundary Flagging

Wooden stakes shall be 4 feet in length with a minimum nominal 3/4" x 1-3/4" cross section. The flagging shall be at least 1" in width. The flagging material shall be vinyl and shall be orange in color and highly visible.

Construction Methods

No additional clearing and grubbing is anticipated for the installation of this fence. The fence shall be erected to conform to the general contour of the ground.

(A) Safety Fencing

Posts shall be set at a maximum spacing of 10 ft., maintained in a vertical position and hand set or set with a post driver. Posts shall be installed a minimum of 2 ft. into the ground. If hand set, all backfill material shall be thoroughly tamped. Wood posts may be sharpened to a dull point if power driven. Posts damaged by power driving shall be removed and replaced prior to final acceptance. The tops of all wood posts shall be cut at a 30-degree angle. The wood posts may, at the option of the Contractor, be cut at this angle either before or after the posts are erected.

The fence geotextile shall be attached to the wood posts with one 2" galvanized wire staple across each cable or to the steel posts with wire or other acceptable means.

Place construction stakes to establish the location of the safety fence in accordance with Article 105-9 or Article 801-1 of the *Standard Specifications*. No direct pay will be made for the staking of the safety fence. All stakeouts for safety fence shall be considered incidental to the work being paid for as "Construction Surveying", except that where there is no pay item for construction surveying, all safety fence stakeout will be performed by state forces.

The Contractor shall be required to maintain the safety fence in a satisfactory condition for the duration of the project as determined by the Engineer.

(B) Boundary Flagging

Boundary flagging delineation of interior boundaries shall consist of wooden stakes on 25 feet maximum intervals with highly visible orange flagging attached. Stakes shall be installed a minimum of 6" into the ground. Interior boundaries may be staked on a tangent that runs parallel to buffer but must not encroach on the buffer at any location. Interior boundaries of hand clearing shall be identified with a different colored flagging to distinguish it from mechanized clearing.

Boundary flagging delineation of interior boundaries will be placed in accordance with Article 105-9 or Article 801-1 of the *Standard Specifications*. No direct pay will be made for delineation of the interior boundaries. This delineation will be considered incidental to the work being paid for as *Construction Surveying*, except that where there is no pay item or construction surveying the cost of boundary flagging delineation shall be included in the unit prices bid for the various items in the contract. Installation for delineation of all jurisdictional boundaries at staging areas, waste sites, or borrow pits shall consist of wooden stakes on 25 feet maximum intervals with highly visible orange flagging attached. Stakes shall be installed a minimum of 6" into the ground. Additional flagging may be placed on overhanging vegetation to enhance visibility but does not substitute for installation of stakes.

Installation of boundary flagging for delineation of all jurisdictional boundaries at staging areas, waste sites, or borrow pits shall be performed in accordance with Subarticle 230-4(B)(5) or Subarticle 802-2(F) of the *Standard Specifications*. No direct pay will be made for this delineation, as the cost of same shall be included in the unit prices bid for the various items in the contract.

The Contractor shall be required to maintain alternative stakes and highly visible flagging in a satisfactory condition for the duration of the project as determined by the Engineer.

Measurement and Payment

Safety Fence will be measured and paid as the actual number of linear feet of polyethylene or polypropylene fence installed in place and accepted. Such payment will be full compensation including but not limited to furnishing and installing fence geotextile with necessary posts and post bracing, staples, tie wires, tools, equipment and incidentals necessary to complete this work.

Payment will be made under:

Pay Item
Safety Fence

Pay Unit
Linear Foot

**Project Special Provisions
Structures
Table of Contents**

Special Provision		Page
Scope of Work		BP-2
Falsework and Formwork	(02-14-22)	BP-2
Crane Safety	(06-20-19)	BP-8
Grout for Structures	(12-01-17)	BP-9
Submittal of Working Drawings	(02-14-22)	BP-10
Foam Joint Seal for Preservation	(SPECIAL)	BP-15
Elastomeric Concrete for Preservation	(02-11-19)	BP-19
Bridge Joint Demolition	(SPECIAL)	BP-21
Silane Deck Treatment	(SPECIAL)	BP-22
Silane Barrier Rail Treatment	(SPECIAL)	BP-27

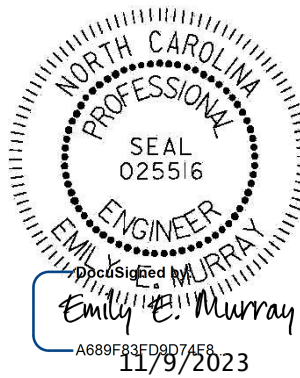

HI-0016

BP-2

Robeson County

SCOPE OF WORK

This work shall consist of furnishing all labor, equipment, and materials to apply silane deck treatment, and replace joints, as directed in the plans. Work includes: portable lighting; existing bridge deck surface preparation by shot blasting; installation of foam joint seals with elastomeric headers; disposal of demolition and waste material; seeding and mulching all grassed areas disturbed; and all incidental items necessary to complete the project as specified and shown on the plans. No separate payment will be made for portable lighting as the cost of such is incidental to the work being performed.

Work will be performed on the existing bridges in Robeson County at the following locations:

- 1) Bridge #770110 on US 74 WBL/NC 130 WBL over Lumber River Overflow
- 2) Bridge #770465 on US 74 EBL/NC 130 EBL over Lumber River Overflow
- 3) Bridge #770118 on US 74 WBL/NC 130 WBL over Lumber River
- 4) Bridge #770466 on US 74 EBL/NC 130 EBL over Lumber River
- 5) Bridge #770490 on SR 2210 over US 74
- 6) Bridge #770512 on SR 2220 over US 74

Contractor shall provide all necessary access; provide all traffic control; provide all staging areas; material storage; waste disposal; provide environmental controls to limit loss of materials from collection of sawing equipment and chipping equipment; and all else necessary to complete the work.

The contractor shall be responsible for fulfilling all requirements of the NCDOT Standard Specifications for Roads and Structures dated January 2018, except as otherwise specified herein.

FALSEWORK AND FORMWORK**(2-14-22)****1.0 DESCRIPTION**

Use this Special Provision as a guide to develop temporary works submittals required by the Standard Specifications or other provisions; no additional submittals are required herein. Such temporary works include, but are not limited to, falsework and formwork.

Falsework is any temporary construction used to support the permanent structure until it becomes self-supporting. Formwork is the temporary structure or mold used to retain plastic or fluid concrete in its designated shape until it hardens. Access scaffolding is a temporary structure that functions as a work platform that supports construction personnel, materials, and tools, but is not intended to support the structure. Scaffolding systems that are used to temporarily support permanent structures (as opposed to functioning as work platforms) are considered to be falsework under the definitions given. Shoring is a component of falsework such as horizontal, vertical, or inclined support members. Where the term "temporary works" is used, it includes all of the temporary facilities used in bridge construction that do not become part of the permanent structure.

Design and construct safe and adequate temporary works that will support all loads imposed and provide the necessary rigidity to achieve the lines and grades shown on the plans in the final structure.

HI-0016

BP-3

Robeson County

2.0 MATERIALS

Select materials suitable for temporary works; however, select materials that also ensure the safety and quality required by the design assumptions. The Engineer has authority to reject material on the basis of its condition, inappropriate use, safety, or nonconformance with the plans. Clearly identify allowable loads or stresses for all materials or manufactured devices on the plans. Revise the plan and notify the Engineer if any change to materials or material strengths is required.

3.0 DESIGN REQUIREMENTS**A. Working Drawings**

Provide working drawings for items as specified in the contract, or as required by the Engineer, with design calculations and supporting data in sufficient detail to permit a structural and safety review of the proposed design of the temporary work.

On the drawings, show all information necessary to allow the design of any component to be checked independently as determined by the Engineer.

When concrete placement is involved, include data such as the drawings of proposed sequence, rate of placement, direction of placement, and location of all construction joints.

When required, have the drawings and calculations prepared under the guidance of, and sealed by, a North Carolina Registered Professional Engineer who is knowledgeable in temporary works design.

If requested by the Engineer, submit with the working drawings manufacturer's catalog data listing the weight of all construction equipment that will be supported on the temporary work. Show anticipated total settlements and/or deflections of falsework and forms on the working drawings. Include falsework footing settlements, joint take-up, and deflection of beams or girders.

As an option for the Contractor, overhang falsework hangers may be uniformly spaced, at a maximum of 36 inches, provided the following conditions are met:

Member Type (PCG)	Member Depth, (inches)	Max. Overhang Width, (inches)	Max. Slab Edge Thickness, (inches)	Max. Screenshot Wheel Weight, (lbs.)	Bracket Min. Vertical Leg Extension, (inches)
II	36	39	14	2000	26
III	45	42	14	2000	35
IV	54	45	14	2000	44
MBT	63	51	12	2000	50
MBT	72	55	12	1700	48

Overhang width is measured from the centerline of the girder to the edge of the deck slab. For Type II, III & IV prestressed concrete girders (PCG), 45-degree cast-in-place half hangers and rods must have a minimum safe working load of 6,000 lbs.

For MBT prestressed concrete girders, 45-degree angle holes for falsework hanger rods shall be cast through the girder top flange and located, measuring along the top of the member, 1'-2

HI-0016

BP-4

Robeson County

½” from the edge of the top flange. Hanger hardware and rods must have a minimum safe working load of 6,000 lbs.

For links slabs, the tops of girders directly beneath the link slab shall be free of overhang falsework attachments or other hardware. Submit calculations and working drawings for overhang falsework in the link slab region.

The overhang bracket provided for the diagonal leg shall have a minimum safe working load of 3,750 lbs. The vertical leg of the bracket shall extend to the point that the heel bears on the girder bottom flange, no closer than 4 inches from the bottom of the member. However, for 72-inch members, the heel of the bracket shall bear on the web, near the bottom flange transition.

Provide adequate overhang falsework and determine the appropriate adjustments for deck geometry, equipment, casting procedures and casting conditions.

If the optional overhang falsework spacing is used, indicate this on the falsework submittal and advise the girder producer of the proposed details. Failure to notify the Engineer of hanger type and hanger spacing on prestressed concrete girder casting drawings may delay the approval of those drawings.

Falsework hangers that support concentrated loads and are installed at the edge of thin top flange concrete girders (such as bulb tee girders) shall be spaced so as not to exceed 75% of the manufacturer's stated safe working load. Use of dual leg hangers (such as Meadow Burke HF-42 and HF-43) are not allowed on concrete girders with thin top flanges. Design the falsework and forms supporting deck slabs and overhangs on girder bridges so that there will be no differential settlement between the girders and the deck forms during placement of deck concrete.

When staged construction of the bridge deck is required, detail falsework and forms for screed and fluid concrete loads to be independent of any previous deck pour components when the mid-span girder deflection due to deck weight is greater than ¾”.

Note on the working drawings any anchorages, connectors, inserts, steel sleeves or other such devices used as part of the falsework or formwork that remains in the permanent structure. If the plan notes indicate that the structure contains the necessary corrosion protection required for a Corrosive Site, epoxy coat, galvanize or metalize these devices. Electroplating will not be allowed. Any coating required by the Engineer will be considered incidental to the various pay items requiring temporary works.

Design falsework and formwork requiring submittals in accordance with the 1995 AASHTO *Guide Design Specifications for Bridge Temporary Works* except as noted herein.

1. Wind Loads

HI-0016

BP-5

Robeson County

Table 2.2 of Article 2.2.5.1 is modified to include wind velocities up to 110 mph. In addition, Table 2.2A is included to provide the maximum wind speeds by county in North Carolina.

Table 2.2 - Wind Pressure Values

Height Zone feet above ground	Pressure, lb/ft ² for Indicated Wind Velocity, mph				
	70	80	90	100	110
0 to 30	15	20	25	30	35
30 to 50	20	25	30	35	40
50 to 100	25	30	35	40	45
over 100	30	35	40	45	50

2. Time of Removal

The following requirements replace those of Article 3.4.8.2.

Do not remove forms until the concrete has attained strengths required in Article 420-16 of the Standard Specifications and these Special Provisions.

Do not remove forms until the concrete has sufficient strength to prevent damage to the surface.

HI-0016

BP-6

Robeson County

Table 2.2A - Steady State Maximum Wind Speeds by Counties in North Carolina

COUNTY	25 YR (mph)	COUNTY	25 YR (mph)	COUNTY	25 YR (mph)
Alamance	70	Franklin	70	Pamlico	100
Alexander	70	Gaston	70	Pasquotank	100
Alleghany	70	Gates	90	Pender	100
Anson	70	Graham	80	Perquimans	100
Ashe	70	Granville	70	Person	70
Avery	70	Greene	80	Pitt	90
Beaufort	100	Guilford	70	Polk	80
Bertie	90	Halifax	80	Randolph	70
Bladen	90	Harnett	70	Richmond	70
Brunswick	100	Haywood	80	Robeson	80
Buncombe	80	Henderson	80	Rockingham	70
Burke	70	Hertford	90	Rowan	70
Cabarrus	70	Hoke	70	Rutherford	70
Caldwell	70	Hyde	110	Sampson	90
Camden	100	Iredell	70	Scotland	70
Carteret	110	Jackson	80	Stanley	70
Caswell	70	Johnston	80	Stokes	70
Catawba	70	Jones	100	Surry	70
Cherokee	80	Lee	70	Swain	80
Chatham	70	Lenoir	90	Transylvania	80
Chowan	90	Lincoln	70	Tyrell	100
Clay	80	Macon	80	Union	70
Cleveland	70	Madison	80	Vance	70
Columbus	90	Martin	90	Wake	70
Craven	100	McDowell	70	Warren	70
Cumberland	80	Mecklenburg	70	Washington	100
Currituck	100	Mitchell	70	Watauga	70
Dare	110	Montgomery	70	Wayne	80
Davidson	70	Moore	70	Wilkes	70
Davie	70	Nash	80	Wilson	80
Duplin	90	New Hanover	100	Yadkin	70
Durham	70	Northampton	80	Yancey	70
Edgecombe	80	Onslow	100		
Forsyth	70	Orange	70		

B. Review and Approval

The Engineer is responsible for the review and approval of temporary works' drawings.

Submit the working drawings sufficiently in advance of proposed use to allow for their review, revision (if needed), and approval without delay to the work.

The time period for review of the working drawings does not begin until complete drawings and design calculations, when required, are received by the Engineer.

Do not start construction of any temporary work for which working drawings are required until the drawings have been approved. Such approval does not relieve the Contractor of the responsibility for the accuracy and adequacy of the working drawings.

4.0 CONSTRUCTION REQUIREMENTS

All requirements of Section 420 of the Standard Specifications apply.

Construct temporary works in conformance with the approved working drawings. Ensure that the quality of materials and workmanship employed is consistent with that assumed in the design of the temporary works. Do not weld falsework members to any portion of the permanent structure unless approved. Show any welding to the permanent structure on the approved construction drawings.

Provide tell-tales attached to the forms and extending to the ground, or other means, for accurate measurement of falsework settlement. Make sure that the anticipated compressive settlement and/or deflection of falsework does not exceed 1 inch. For cast-in-place concrete structures, make sure that the calculated deflection of falsework flexural members does not exceed 1/240 of their span regardless of whether or not the deflection is compensated by camber strips.

A. Maintenance and Inspection

Inspect and maintain the temporary work in an acceptable condition throughout the period of its use. Certify that the manufactured devices have been maintained in a condition to allow them to safely carry their rated loads. Clearly mark each piece so that its capacity can be readily determined at the job site.

Perform an in-depth inspection of an applicable portion(s) of the temporary works, in the presence of the Engineer, not more than 24 hours prior to the beginning of each concrete placement. Inspect other temporary works at least once a month to ensure that they are functioning properly. Have a North Carolina Registered Professional Engineer inspect the cofferdams, shoring, sheathing, support of excavation structures, and support systems for load tests prior to loading.

HI-0016

BP-8

Robeson County

B. Foundations

Determine the safe bearing capacity of the foundation material on which the supports for temporary works rest. If required by the Engineer, conduct load tests to verify proposed bearing capacity values that are marginal or in other high-risk situations.

The use of the foundation support values shown on the contract plans of the permanent structure is permitted if the foundations are on the same level and on the same soil as those of the permanent structure.

Allow for adequate site drainage or soil protection to prevent soil saturation and washout of the soil supporting the temporary works supports.

If piles are used, the estimation of capacities and later confirmation during construction using standard procedures based on the driving characteristics of the pile is permitted. If preferred, use load tests to confirm the estimated capacities; or, if required by the Engineer conduct load tests to verify bearing capacity values that are marginal or in other high risk situations.

The Engineer reviews and approves the proposed pile and soil bearing capacities.

5.0 REMOVAL

Unless otherwise permitted, remove and keep all temporary works upon completion of the work. Do not disturb or otherwise damage the finished work.

Remove temporary works in conformance with the contract documents. Remove them in such a manner as to permit the structure to uniformly and gradually take the stresses due to its own weight.

6.0 METHOD OF MEASUREMENT

Unless otherwise specified, temporary works will not be directly measured.

7.0 BASIS OF PAYMENT

Payment at the contract unit prices for the various pay items requiring temporary works will be full compensation for the above falsework and formwork.

CRANE SAFETY**(6-20-19)**

Comply with the manufacturer specifications and limitations applicable to the operation of any and all cranes and derricks. Prime contractors, sub-contractors, and fully operated rental companies shall comply with the current Occupational Safety and Health Administration (OSHA) regulations.

Submit all items listed below to the Engineer prior to beginning crane operations. Changes in personnel or equipment must be reported to the Engineer and all applicable items listed below must be updated and submitted prior to continuing with crane operations.

HI-0016

BP-9

Robeson County

CRANE SAFETY SUBMITTAL LIST

- A. **Competent Person:** Provide the name and qualifications of the “Competent Person” responsible for crane safety and lifting operations. The named competent person will have the responsibility and authority to stop any work activity due to safety concerns.
- B. **Riggers:** Provide the qualifications and experience of the persons responsible for rigging operations. Qualifications and experience should include, but not be limited to, weight calculations, center of gravity determinations, selection and inspection of sling and rigging equipment, and safe rigging practices.
- C. **Crane Inspections:** Inspection records for all cranes shall be current and readily accessible for review upon request.
- D. **Certifications:** Crane operators shall be certified by the National Commission for the Certification of Crane Operators (NCCCO) or the National Center for Construction Education and Research (NCCER). Other approved nationally accredited programs will be considered upon request. In addition, crane operators shall have a current CDL medical card. Submit a list of crane operator(s) and include current certification for each type of crane operated (small hydraulic, large hydraulic, small lattice, large lattice) and medical evaluations for each operator.

GROUT FOR STRUCTURES**(12-1-17)****DESCRIPTION**

This special provision addresses grout for use in pile blockouts, grout pockets, shear keys, dowel holes and recesses for structures. This provision does not apply to grout placed in post-tensioning ducts for bridge beams, girders, decks, end bent caps, or bent caps. Mix and place grout in accordance with the manufacturer’s recommendations, the applicable sections of the Standard Specifications and this provision.

MATERIAL REQUIREMENTS

Unless otherwise noted on the plans, use a Type 3 Grout in accordance with Section 1003 of the Standard Specifications.

Initial setting time shall not be less than 10 minutes when tested in accordance with ASTM C266.

Construction loading and traffic loading shall not be allowed until the 3 day compressive strength is achieved.

SAMPLING AND PLACEMENT

Place and maintain components in final position until grout placement is complete and accepted. Concrete surfaces to receive grout shall be free of defective concrete, laitance, oil, grease and other foreign matter. Saturate concrete surfaces with clean water and remove excess water prior to placing grout.

HI-0016

BP-10

Robeson County

BASIS OF PAYMENT

No separate payment will be made for “Grout for Structures”. The cost of the material, equipment, labor, placement, and any incidentals necessary to complete the work shall be considered incidental to the structure item requiring grout.

SUBMITTAL OF WORKING DRAWINGS**(2-14-22)****1.0 GENERAL**

Submit working drawings in accordance with Article 105-2 of the *Standard Specifications* and this provision. For this provision, “submittals” refers to only those listed in this provision. The list of submittals contained herein does not represent a list of required submittals for the project. Submittals are only necessary for those items as required by the contract. Make submittals that are not specifically noted in this provision directly to the Engineer. Either the Structures Management Unit or the Geotechnical Engineering Unit or both units will jointly review submittals.

If a submittal contains variations from plan details or specifications or significantly affects project cost, field construction or operations, discuss the submittal with and submit all copies to the Engineer. State the reason for the proposed variation in the submittal. To minimize review time, make sure all submittals are complete when initially submitted. Provide a contact name and information with each submittal. Direct any questions regarding submittal requirements to the Engineer, Structures Management Unit contacts or the Geotechnical Engineering Unit contacts noted below.

To facilitate in-plant inspection by NCDOT and approval of working drawings, provide the name, address and telephone number of the facility where fabrication will actually be done if different than shown on the title block of the submitted working drawings. This includes, but is not limited to, precast concrete items, prestressed concrete items and fabricated steel or aluminum items.

2.0 ADDRESSES AND CONTACTS

For submittals to the Structures Management Unit, use the following addresses:

Via Email: SMU-wdr@ncdot.gov (do not cc SMU Working Drawings staff)

Via US mail:

Mr. B. C. Hanks, P. E.
State Structures Engineer
North Carolina Department
of Transportation
Structures Management Unit
1581 Mail Service Center
Raleigh, NC 27699-1581

Attention: Mr. J. L. Bolden, P. E.

Via other delivery service:

Mr. B. C. Hanks, P. E.
State Structures Engineer
North Carolina Department
of Transportation
Structures Management Unit
1000 Birch Ridge Drive
Raleigh, NC 27610

Attention: Mr. J. L. Bolden, P. E.

HI-0016

BP-11

Robeson County

For submittals to the Geotechnical Engineering Unit, use the following addresses:

For projects in Divisions 1-7, use the following Eastern Regional Office addresses:

Via Email: EastGeotechnicalSubmittal@ncdot.gov

Via US mail:

Mr. David Hering, L.G., P. E.
Assistant State Geotechnical
Engineer – Eastern Region
North Carolina Department
of Transportation
Geotechnical Engineering Unit
Eastern Regional Office
1570 Mail Service Center
Raleigh, NC 27699-1570

Via other delivery service:

Mr. David Hering, L.G., P. E.
Assistant State Geotechnical
Engineer – Eastern Region
North Carolina Department
of Transportation
Geotechnical Engineering Unit
Eastern Regional Office
3301 Jones Sausage Road, Suite 100
Garner, NC 27529

For projects in Divisions 8-14, use the following Western Regional Office addresses:

Via Email: WestGeotechnicalSubmittal@ncdot.gov

Via US mail or other delivery service:

Mr. Eric Williams, P. E.
Assistant State Geotechnical
Engineer – Western Region
North Carolina Department
of Transportation
Geotechnical Engineering Unit
Western Regional Office
5253 Z Max Boulevard
Harrisburg, NC 28075

The status of the review of structure-related submittals sent to the Structures Management Unit can be viewed from the Unit’s website, via the “[Drawing Submittal Status](#)” link.

The status of the review of geotechnical-related submittals sent to the Geotechnical Engineering Unit can be viewed from the Unit’s website, via the “[Geotechnical Construction Submittals](#)” link.

Direct any questions concerning submittal review status, review comments or drawing markups to the following contacts:

Primary Structures Contact: James Bolden (919) 707 – 6408
jlbolden@ncdot.gov

Secondary Structures Contacts: Emmanuel Omile (919) 707 – 6451
comile@ncdot.gov

Madonna Rorie (919) 707 – 6508
mrorie@ncdot.gov

HI-0016

BP-12

Robeson County

Eastern Regional Geotechnical Contact (Divisions 1-7):

David Hering (919) 662 – 4710
dthering@ncdot.gov

Western Regional Geotechnical Contact (Divisions 8-14):

Eric Williams (704) 455 – 8902
ewilliams3@ncdot.gov**3.0 SUBMITTAL COPIES**

Furnish one complete copy of each submittal, including all attachments, to the Engineer. At the same time, submit a copy of the same complete submittal directly to the Structures Management Unit and/or the Geotechnical Engineering Unit as specified in the tables below.

The first table below covers “Structure Submittals.” The Engineer will receive review comments and drawing markups for these submittals from the Structures Management Unit. The second table in this section covers “Geotechnical Submittals.” The Engineer will receive review comments and drawing markups for these submittals from the Geotechnical Engineering Unit.

Unless otherwise required, submit one set of supporting calculations to either the Structures Management Unit or the Geotechnical Engineering Unit unless both units require submittal copies in which case submit a set of supporting calculations to each unit. Provide additional copies of any submittal as directed.

STRUCTURE SUBMITTALS

Submittal	Submittal Required by Structures Management Unit?	Submittal Required by Geotechnical Engineering Unit?	Contract Reference Requiring Submittal ¹
Arch Culvert Falsework	Y	N	Plan Note, SN Sheet & “Falsework and Formwork”
Box Culvert Falsework ⁷	Y	N	Plan Note, SN Sheet & “Falsework and Formwork”
Cofferdams	Y	Y	Article 410-4
Foam Joint Seals ⁶	Y	N	“Foam Joint Seals”
Expansion Joint Seals (hold down plate type with base angle)	Y	N	“Expansion Joint Seals”
Expansion Joint Seals (modular)	Y	N	“Modular Expansion Joint Seals”
Expansion Joint Seals (strip seals)	Y	N	“Strip Seal Expansion Joints”

HI-0016

BP-13

Robeson County

Falsework & Forms ² (substructure)	Y	N	Article 420-3 & “Falsework and Formwork”
Falsework & Forms (superstructure)	Y	N	Article 420-3 & “Falsework and Formwork”
Girder Erection over Railroad	Y	N	Railroad Provisions
Maintenance and Protection of Traffic Beneath Proposed Structure	Y	N	“Maintenance and Protection of Traffic Beneath Proposed Structure at Station ____”
Metal Bridge Railing	Y	N	Plan Note
Metal Stay-in-Place Forms	Y	N	Article 420-3
Metalwork for Elastomeric Bearings ^{4,5}	Y	N	Article 1072-8
Miscellaneous Metalwork ^{4,5}	Y	N	Article 1072-8
Disc Bearings ⁴	Y	N	“Disc Bearings”
Overhead and Digital Message Signs (DMS) (metalwork and foundations)	Y	N	Applicable Provisions
Placement of Equipment on Structures (cranes, etc.)	Y	N	Article 420-20
Prestressed Concrete Box Beam (detensioning sequences) ³	Y	N	Article 1078-11
Precast Concrete Box Culverts	Y	N	“Optional Precast Reinforced Concrete Box Culvert at Station ____”
Prestressed Concrete Cored Slab (detensioning sequences) ³	Y	N	Article 1078-11
Prestressed Concrete Deck Panels	Y	N	Article 420-3
Prestressed Concrete Girder (strand elongation and detensioning sequences)	Y	N	Articles 1078-8 and 1078-11
Removal of Existing Structure over Railroad	Y	N	Railroad Provisions
Revised Bridge Deck Plans (adaptation to prestressed deck panels)	Y	N	Article 420-3

HI-0016

BP-14

Robeson County

Revised Bridge Deck Plans (adaptation to modular expansion joint seals)	Y	N	“Modular Expansion Joint Seals”
Sound Barrier Wall (precast items)	Y	N	Article 1077-2 & “Sound Barrier Wall”
Sound Barrier Wall Steel Fabrication Plans ⁵	Y	N	Article 1072-8 & “Sound Barrier Wall”
Structural Steel ⁴	Y	N	Article 1072-8
Temporary Detour Structures	Y	Y	Article 400-3 & “Construction, Maintenance and Removal of Temporary Structure at Station _____”
TFE Expansion Bearings ⁴	Y	N	Article 1072-8

FOOTNOTES

1. References are provided to help locate the part of the contract where the submittals are required. References in quotes refer to the provision by that name. Articles refer to the *Standard Specifications*.
2. Submittals for these items are necessary only when required by a note on plans.
3. Submittals for these items may not be required. A list of pre-approved sequences is available from the producer or the Materials & Tests Unit.
4. The fabricator may submit these items directly to the Structures Management Unit.
5. The two sets of preliminary submittals required by Article 1072-8 of the *Standard Specifications* are not required for these items.
6. Submittals for Fabrication Drawings are not required. Submittals for Catalogue Cuts of Proposed Material are required. See Section 5.A of the referenced provision.
7. Submittals are necessary only when the top slab thickness is 18” or greater.

HI-0016

BP-15

Robeson County

GEOTECHNICAL SUBMITTALS

Submittal	Submittals Required by Geotechnical Engineering Unit	Submittals Required by Structures Management Unit	Contract Reference Requiring Submittal ¹
Drilled Pier Construction Plans ²	Y	N	Subarticle 411-3(A)
Crosshole Sonic Logging (CSL) Reports ²	Y	N	Subarticle 411-5(A)(2)
Pile Driving Equipment Data Forms ^{2,3}	Y	N	Subarticle 450-3(D)(2)
Pile Driving Analyzer (PDA) Reports ²	Y	N	Subarticle 450-3(F)(3)
Retaining Walls ⁴	Y; drawings and calculations	Y; drawings	Applicable Provisions
Temporary Shoring ⁴	Y; drawings and calculations	Y; drawings	“Temporary Shoring” & “Temporary Soil Nail Walls”

FOOTNOTES

- References are provided to help locate the part of the contract where the submittals are required. References in quotes refer to the provision by that name. Subarticles refer to the *Standard Specifications*.
- Submit one hard copy of submittal to the Engineer. Submit a second copy of submittal electronically (PDF via email), US mail or other delivery service to the appropriate Geotechnical Engineering Unit regional office. Electronic submission is preferred.
- The Pile Driving Equipment Data Form is available from:
https://connect.ncdot.gov/resources/Geological/Pages/Geotech_Forms_Details.aspx
See second page of form for submittal instructions.
- Electronic copy of submittal is required. See referenced provision.

FOAM JOINT SEALS FOR PRESERVATION**(SPECIAL)****SEALS**

Use preformed seals compatible with concrete and resistant to abrasion, oxidation, oils, gasoline, salt, and other materials that are spilled on or applied to the surface. Use a resilient, UV stable, preformed, impermeable, flexible, expansion joint seal. The joint seal shall consist of low-density, closed cell, cross-

HI-0016

BP-16

Robeson County

linked polyethylene non-extrudable foam. The joint seal shall contain no EVA (Ethylene Vinyl Acetate). Cell generation shall be achieved by being physically blown using nitrogen. No chemical blowing agents shall be used in the cell generation process.

Use seals manufactured with grooves $1/8'' \pm$ wide by $1/8'' \pm$ deep and spaced between $1/4''$ and $1/2''$ apart along the bond surface running the length of the joint. Use seals with a depth that meets the manufacturer's recommendation, but is not less than 70% of the uncompressed width. Provide a seal designed so that, when compressed, the center portion of the top does not extend upward above the original height of the seal by more than $1/4''$. Provide a seal that has a working range of 30% tension and 60% compression and meets the requirements given below.

TEST	TEST METHOD	REQUIREMENT
Tensile Strength	ASTM D3575, Suffix T	110 – 130 psi
Compression Set	ASTM D1056 Suffix B, 2 hr recovery	10% - 16%
Water Absorption	ASTM D3575	< 0.03 lb/ft ²
Elongation at Break	ASTM D3575	180% - 210%
Tear Resistance	ASTM D624 (D3575, Suffix G)	14 – 20 pli
Density	ASTM D3575, Suffix W, Method A	1.8 – 2.2 lb/ft ³
Toxicity	ISO-10993.5	Pass (not cytotoxic)

Have the top of the joint seal clearly shop marked. Inspect the joint seals upon receipt to ensure that the marks are clearly visible before installation.

BONDING ADHESIVE

Use a two-component, 100% solid, modified epoxy adhesive supplied by the joint seal manufacturer that meets the requirements given below.

TEST	TEST METHOD	REQUIREMENT
Tensile strength	ASTM D638	3,000 psi (min.)
Compressive strength	ASTM D695	7,000 psi (min.)
Hardness	Shore D Scale	75-85 psi
Water Absorption	ASTM D570	0.25% by weight max.
Elongation to Break	ASTM D638	5% (max.)
Bond Strength	ASTM C882	2,000 psi (min.)

Use an adhesive that is workable to 40°F. When installing in ambient air or surface temperatures below 40°F or for application on moist, difficult to dry concrete surfaces, use an adhesive specified by the manufacturer of the joint seal.

SAWING THE JOINT

The concrete at the face of the joint (elastomeric concrete, polyester polymer concrete, Portland cement concrete, etc.) shall have sufficient time to cure such that no damage can occur to the concrete prior to sawing to the final width and depth as specified in the plans.

When sawing the joint to receive the foam seal, always use a rigid guide to control the saw in the desired direction. To control the saw and to produce a straight line as indicated on the plans, anchor and positively connect a template or a track to the bridge deck. Do not saw the joint by visual means such as a chalk line. Fill the holes used for holding the template or track to the deck with an approved flowable, non-shrink, non-metallic grout.

Saw cut to the desired width and depth in one (1) or two (2) passes of the saw by placing and spacing two (2) metal blades on the saw shaft to the desired width for the joint opening.

The desired depth is the depth of the seal plus ¼" above the top of the seal plus approximately 1" below the bottom of the seal. An irregular bottom of sawed joint is permitted as indicated on the plans. Grind exposed corners on saw cut edges to a ¼" chamfer.

Saw cut a straight joint, centered over the formed opening and to the desired width specified in the plans. Prevent any chipping or damage to the sawed edges of the joint.

Remove any staining or deposited material resulting from sawing with a wet blade to the satisfaction of the Engineer.

PREPARATION OF SAWED JOINT FOR SEAL INSTALLATION

The elastomeric concrete or polyester polymer concrete at the joint shall cure a minimum of 24 hours prior to seal installation. Portland cement concrete at the joint shall cure following the special provisions.

After sawing the joint, the Engineer will thoroughly inspect the sawed joint opening for spalls, popouts, cracks, etc. All necessary repairs will be made by the Contractor prior to blast cleaning and installing the seal, at no cost to the Department.

Clean the joints by sandblasting with clean dry sand immediately before placing the bonding agent. Sandblast the joint opening to provide a firm, clean joint surface free of curing compound, loose material and any foreign matter. Sandblast the joint opening without causing pitting or uneven surfaces. The aggregate in the joint concrete may be exposed after sandblasting.

After blasting, either brush the surface with clean brushes made of hair, bristle, or fiber, blow the surface with compressed air, or vacuum the surface until all traces of blast products and abrasives are removed from the surface, pockets, and corners.

If nozzle blasting is used to clean the joint opening, use compressed air that does not contain detrimental amounts of water or oil.

Examine the blast-cleaned surface and remove any traces of oil, grease, or smudge deposited in the cleaning operations.

Bond the seal to the blast-cleaned surface on the same day the surface is blast cleaned.

SEAL INSTALLATION

Install the joint seal according to the manufacturer's procedures and recommendations and as recommended below. Do not install the joint seal if the ambient air or surface temperature is below 45°F. Have a manufacturer's certified trained factory representative present during the installation of the first seal of the project.

Before installing the joint seal, check the uninstalled seal length to ensure the seal is the same length as the deck opening. When the joint seal requires splicing, use the heat welding method by placing the joint material ends against a Teflon heating iron of 425-475°F for 7 - 10 seconds, then pressing the ends together tightly. Do not test the welding until the material has completely cooled.

Begin installation by protecting the top edges of the concrete deck adjacent to the vertical walls of the joint as a means to minimize clean up. Stir each epoxy bonding agent component independently, using separate stirring rods for each component to prevent premature curing of the bonding agent. Pour the two (2) components, at the specified mixing ratio, into a clean mixing bucket. Mix the components with a low speed drill (400 rpm max.) until a uniform gray color is achieved without visible marbling. Apply bonding agent to both sides of the joint concrete, as well as both sides of the joint seal, making certain to fill completely the grooves with epoxy. With gloved hands, compress the joint seal and with the help of a blunt probe, push the seal into the joint opening until the seal is recessed approximately 1/4" below the surface. When pushing down on the joint seal, apply pressure only in a downward direction. Do not push the joint seal into the joint opening at an angle that would stretch the material. Seals that are stretched during installation shall be removed and rejected. Once work on placing a seal begins, do not stop until it is completed. Clean the excess epoxy from the top of the joint seal immediately with a trowel. Do not use solvents or any cleaners to remove the excess epoxy from the top of the seal. Remove the protective cover at the joint edges and check for any excess epoxy on the surface. Remove excess epoxy with a trowel, the use of solvents or any cleaners will not be allowed.

The installed system shall be watertight and will be monitored until final inspection and approval.

(A) Watertight Integrity Test

- (1) Upon completion of each foam seal expansion joint, perform a water test on the top surface to detect any leakage. Cover the roadway section of the joint from curb to curb, or barrier rail to barrier rail, with water, either ponded or flowing, not less than 1 inch above the roadway surface at all points. Block sidewalk sections and secure an unnozzled water hose delivering approximately 1 gallon of water per minute to the inside face of the bridge railing, trained in a downward position about six (6) inches above the sidewalk, such that there is continuous flow of water across the sidewalk and down the curb face of the joint.
- (2) Maintain the ponding or flowing of water on the roadway and continuous flow across sidewalks and curbs for a period of five (5) hours. At the conclusion of the test, the underside of the joint is closely examined for leakage. The foam seal expansion joint is considered watertight if no obvious wetness is visible on the Engineer's finger after touching a number of underdeck areas. Damp concrete that does not impart wetness to the finger is not considered a sign of leakage.
- (3) If the joint system leaks, locate the place(s) of leakage and take any repair measures necessary to stop the leakage at no additional cost to the Department. Use repair measures recommended by the manufacturer and approved by the Engineer prior to beginning corrective work.

HI-0016

BP-19

Robeson County

- (4) If measures to eliminate leakage are taken, perform a subsequent water integrity test subject to the same conditions as the original test. Subsequent tests carry the same responsibility as the original test and are performed at no additional cost to the Department.

Do not place pavement markings on top of foam joint seals.

BASIS OF PAYMENT

Foam Joint Seals for Preservation will be measured and paid for at the contract unit price bid per linear foot and will be full compensation for furnishing all material, labor, tools, and equipment necessary for installing these seals in place and accepted.

Pay Item

Foam Joint Seals for Preservation

Pay Unit

Linear Feet

ELASTOMERIC CONCRETE FOR PRESERVATION**(2-11-19)****DESCRIPTION**

Elastomeric concrete is a mixture of a two-part polymer consisting of polyurethane and/or epoxy and kiln-dried aggregate. Provide an elastomeric concrete and binder system that is preapproved. Use the concrete in the blocked-out areas on both sides of the bridge deck joints as indicated on the plans.

MATERIALS

Provide materials that comply with the following minimum requirements at 14 days (or at the end of the specified curing time).

ELASTOMERIC CONCRETE PROPERTIES	TEST METHOD	MINIMUM REQUIREMENT
Compressive Strength, psi	ASTM D695	2000
5% Deflection Resilience	ASTM D695	95
Splitting Tensile Strength, psi	ASTM D3967	625
Bond Strength to Concrete, psi	ASTM C882 (C882M)	450
Durometer Hardness	ASTM D2240	50

BINDER PROPERTIES (without aggregate)	TEST METHOD	MINIMUM REQUIREMENT
Tensile Strength, psi	ASTM D638	1000
Ultimate Elongation	ASTM D638	150%
Tear Resistance, lb/in	ASTM D624	200

HI-0016

BP-20

Robeson County

In addition to the requirements above, the elastomeric concrete must be resistant to water, chemical, UV and ozone exposure and withstand temperature extremes. Elastomeric concrete systems requiring preheated aggregates are not allowed.

PREQUALIFICATION

Manufacturers of elastomeric concrete materials shall submit samples (including aggregate, primer and binder materials) and a Type 3 certification in accordance with Article 106-3 of the *Standard Specifications* for prequalification to:

North Carolina Department of Transportation
Materials and Tests Unit
1801 Blue Ridge Road
Raleigh, NC 27607

Prequalification will be determined for the system. Individual components will not be evaluated, nor will individual components of previously evaluated systems be deemed prequalified for use.

The submitted binder (a minimum volume of 1 gallon) and corresponding aggregate samples will be evaluated for compliance with the Materials requirements specified above. Systems satisfying all of the Materials requirements will be prequalified for a one (1) year period. Before the end of this period new product samples shall be resubmitted for prequalification evaluation.

If, at any time, any formulation or component modifications are made to a prequalified system that system will no longer be approved for use.

INSTALLATION

The elastomeric concrete shall not be placed until the reinforced concrete deck slab or overlay has cured for seven (7) full days and reached a minimum strength of 3,000 psi.

Provide a manufacturer's representative at the bridge site during the installation of the elastomeric concrete to ensure that all steps being performed comply with all manufacturer installation requirements including, but not limited to: weather conditions (ambient temperature, relative humidity, precipitation, wind, etc.), concrete deck surface preparation, binder and aggregate mixing, primer application, elastomeric concrete placement, curing conditions and minimum curing time before joint exposure to traffic. Do not place elastomeric concrete if the ambient air or surface temperature is below 45°F.

Prepare the concrete surface within 48 hours prior to placing the elastomeric concrete. Before placing the elastomeric concrete, all concrete surfaces shall be thoroughly cleaned and dry. Sandblast the concrete surface in the block-out and clear the surface of all loose debris. Do not place the elastomeric concrete until the surface preparation is completed and approved.

Prepare and apply a primer, as per manufacturer's recommendations, to all concrete faces to be in contact with elastomeric concrete, and to areas specified by the manufacturer.

HI-0016

BP-21

Robeson County

Prepare, batch, and place the elastomeric concrete in accordance with the manufacturer's instructions. Place the elastomeric concrete in the areas specified on the plans while the primer is still tacky and within two (2) hours after applying the primer. Trowel the elastomeric concrete to a smooth finish.

The joint opening in the elastomeric concrete shall match the formed opening in the concrete deck prior to sawing the joint.

FIELD SAMPLING

Provide additional production material to allow freshly mixed elastomeric concrete to be sampled for acceptance. A minimum of six (6) 2-inch cube molds and three (3) 3-inch diameter x 6-inch cylinders will be taken by the Department for each day's production. Compression, splitting tensile, and durometer hardness testing will be performed by the Department to determine acceptance. Materials failing to meet the requirements listed above are subject to removal and replacement at no cost to the Department.

BASIS OF PAYMENT

Elastomeric Concrete for Preservation will be measured and paid for at the contract unit price bid per cubic foot and will be full compensation for material, labor, tools, and equipment necessary for satisfactorily installing the elastomeric concrete in place.

Pay Item

Elastomeric Concrete for Preservation

Pay Unit

Cubic Feet

BRIDGE JOINT DEMOLITION**(SPECIAL)****DESCRIPTION**

This special provision addresses the removal of existing joint material and adjacent concrete headers to facilitate the installation of new elastomeric concrete headers and bridge joint seals at the locations noted in the contract plans.

EQUIPMENT

Use the following surface preparation equipment:

- (A) Sawing equipment capable of sawing concrete to a specified depth.
- (B) Power driven hand tools for removal of concrete are required that meet the following requirements:
- (C) Pneumatic hammers weighing a nominal 15 lbs. (7 kg) or less
- (D) Pneumatic hammer chisel-type bits that do not exceed the diameter of the shaft in width.
- (E) Hand tools such as hammers and chisels for removal of final particles of concrete.

REMOVAL AND PREPARATION

Prior to any construction, take the necessary precautions to ensure debris from joint construction is not allowed to fall below the bridge deck.

Remove existing joint material by methods approved by the Engineer. Provide a 1" deep saw cut around the perimeter of areas noted for bridge deck removal.

HI-0016

BP-22

Robeson County

Remove by chipping with hand tools concrete headers adjacent to the joint to the limits shown on the contract plans. Use a small chipping hammer (15 lb. class) to prepare the edges of the repair area to limit micro fractures. In addition, all loose and unsound concrete shall be removed.

In overhangs, removing concrete areas greater than 0.60 ft²/ft length of bridge will require overhang support. Submit the overhang support method to the Engineer for approval.

Care shall be taken not to cut, stretch, or damage any exposed reinforcing steel. Dispose of the removed concrete.

If the condition of the concrete is such that deep spalls or sheer faces result, notify the Engineer for the proper course of action.

Clean, repair or replace rusted or loose reinforcing steel. Thoroughly clean the newly exposed surface to be free of all grease, oil, curing compounds, acids, dirt, or loose debris.

MEASUREMENT AND PAYMENT

Bridge Joint Demolition will be measured and paid for at the contract unit price bid per square foot and will be full compensation for removal, containment and disposal of existing joint material and concrete and shall include the cost of labor, tools, equipment and incidentals necessary to complete the work.

Pay Item	Pay Unit
Bridge Joint Demolition	Square Feet

SILANE DECK TREATMENT**(SPECIAL)****DESCRIPTION**

This work consists of preparation of concrete bridge deck surfaces and the furnishing and application of alkylalkoxysilane (silane) penetrant sealers, with 100% solids, to seal bridge deck surfaces and cracks. Prepare the surface of the concrete deck and apply the silane bridge deck sealer in accordance with this special provision and as indicated on the plans, or as approved by the Engineer.

Work includes: bridge deck surface preparation, placement of silane deck sealer, and any incidentals necessary to complete the project, as specified or as indicated on the plans.

SUBMITTALS

Submit for approval the following requested items and any other relevant documents:

- A safety data sheet (SDS) for each shipment of the silane materials.
- Silane material information and manufacturer's written preparation and application instructions.
- Certification from an independent testing laboratory that the materials meet the requirements of these provisions. Do not incorporate these materials into the project until the Engineer has accepted and approved the certification for the material.
- The dates of manufacture of the silane materials, their lot numbers and date of shelf-life expiration for each lot number.

HI-0016

BP-23

Robeson County

- A table indicating the likely cure time, in minutes, to allow vehicular traffic on the silane-treated deck surface. Provide time for the allowable ambient temperature range, in increments of 10° F.
- A work plan for each structure that includes estimated times for surface preparation and silane application.

MATERIAL DELIVERY AND STORAGE

Store at the site sufficient quantities of silane materials to perform the entire application.

Deliver materials in manufacturer's original, unopened, undamaged containers with identification labels intact. Ensure that each container is clearly marked by the manufacturer with the following information:

- Manufacturer's name and address.
- Product name.
- Date of manufacture.
- Expiration date.
- LOT identification number.
- Container serial number.

Provide the Engineer a certification from the manufacturer, confirming that the silane materials meet the requirements of this special provision. Do not incorporate these materials into the project until the Engineer has accepted and approved the certification for the material. Submit such certification for each LOT of material delivered to the project. In each certification, identify the serial or LOT numbers of the containers certified.

The Engineer may require samples from each LOT or container of materials delivered to the project or from containers at the point of use. When samples are required, furnish samples in accordance with the Engineer's instructions.

Store silane materials in unopened containers in a clean, dry area between 40° F and 90° F. Store containers in a manner that prevents leakage or spillage.

MANUFACTURER'S REPRESENTATIVE

Provide a manufacturer's representative on site for the duration of the surface preparation and silane application work, to provide expert assistance on surface preparation, storage, mixing, application, clean-up, and disposal of materials.

MATERIALS

Provide silane from a single manufacturer, and provide silane that conforms to requirements indicated in Table 1, below.

Table 1
SILANE PROPERTIES

Property	Test Method	Requirement
Silane Content		100%
VOC content	EPA method 24	Less than 350 g/l
Surface Appearance after Application		Unchanged
Flash Point	ASTM D3278	140° F, minimum

HI-0016

BP-24

Robeson County

Resistance to Chloride Ion Penetration	AASHTO T259 and T260	Less than: 0.52 pounds/yd ³ (criteria of 1.5) at 1/2 inch level; 0.00 pounds/yd ³ (criteria of 0.75) at 1 inch level
Water absorption test	ASTM C 642	0.50% maximum/48 hours; 1.5% maximum/50 days
Scaling resistance	ASTM C 672	(non-air-entrained concrete) 0 rating "No Scaling" (100 cycles)
NCHRP 244		
Water weight gain	Series II - cube test	85% reduction, minimum
Absorbed chloride		87% reduction, minimum
Absorbed chloride	Series IV - Southern climate	95% reduction, minimum

SURFACE PREPARATION

Prepare the surface of the concrete deck for application of the silane by shotblasting in order to remove all existing grease, slurry, oils, paint, dirt, striping, curing compound, rust, membrane, weak surface mortar, or any other contaminants that could interfere with the proper adhesion, penetration, and the curing of the silane material.

Prepare a final surface that adheres to the following requirements:

- 1) For areas to receive deck seal treatment, clean by shotblasting. Where approved by the Engineer, abrasive sandblasting may be used in areas that cannot be accessed by the shotblaster. Select the size of shot or sand, and travel speed of the equipment to provide a uniformly clean surface with a uniform profile. Remove striping to the maximum extent determined to be practical by the Engineer using up to three passes with shotblasting, sandblasting, or other approved equipment. Do not expose cleaned surfaces to vehicular traffic unless approved by the Engineer. If the deck becomes contaminated before placing the silane deck sealer, shotblast or abrasive sandblast the contaminated areas to the satisfaction of the Engineer, at no additional cost.
- 2) Prior to silane application, protect cracks on the concrete bridge deck from materials that can interfere with the penetration and the curing of the silane material. Just prior to placement of the silane, remove, by magnets and oil-free compressed air and vacuuming, any loose particles, such that no excess particles remain. The concrete deck shall be completely dry. Power washing will not be allowed.
- 3) The silane manufacturer may suggest cleaning and preparation methods other than those detailed by this special provision. The Engineer must approve such alternative methods prior to implementation.

SILANE APPLICATION**Test Area**

- Test a small area of the surface (minimum 5 ft. by 5 ft.) before general application to ensure desired performance results, aesthetics, and application rates and to verify application technique. Allow 5–7 days for the product to react fully before evaluating. Application rates may vary depending on field conditions.

HI-0016

BP-25

Robeson County

- Conduct at least one absorption test in the test area, using a Rilem Tube Test. Acceptable results are no loss of water in the Rilem tube over a period of 20 minutes. Adjust application to achieve required repellent performance.
- The manufacturer's representative shall assist the Contractor in determining the application rates. Use test applications on actual surfaces to determine accurate application rates. Extremely porous surfaces may require two coats of silane.
- Do not begin production application of silane until Engineer has approved the test area, including approval of aesthetics, color, texture, and appearance.

Application

Immediately before placing silane, all exposed surfaces shall be completely dry and blown clean with oil-free compressed air to remove any loose dust and debris. Apply silane as soon as practical after the exposed surfaces have been properly prepared and conditions are satisfactory:

- Stir material thoroughly before and during application.
- Apply silane with low-pressure spray or by flooding, followed by brooming or squeegeeing for even distribution, in accordance with manufacturer's instructions.
- Maintain operating pressures in sprayers used for application of the silane sealer material sufficiently low so that atomization or misting of the material does not occur.
- Begin the application of the silane at the lowest elevation and proceed upward, toward higher elevations, unless otherwise approved by the Engineer.
- Apply even distribution of silane. Avoid ponding of silane; take care when applying the silane, so that running or puddling does not occur.
- Apply silane in a single application to the concrete deck surface with enough material to saturate the surface. Remove excess material with a broom or squeegee and dispose of excess material appropriately. If a second coat is required, it should be applied "wet on wet" before first coat dries.
- Application of sealant by spray methods will not be permitted when wind speeds are 20 mph or more, or if in the opinion of the Engineer, unsatisfactory results will be obtained. Other application methods or rescheduling will be required.
- Avoid application with hand pump sprayers. For small areas of silane application, the use of hand pump sprayers must be approved by the Engineer.
- Contractor shall protect from overspray all pedestrians, vehicles, plants and vegetation, and other areas not receiving silane application.
- Allow product to penetrate the bridge deck and dry, as required by the manufacturer, prior to opening to traffic.

LIMITATIONS OF OPERATIONS

- Prior to application of any silane sealer, cure concrete or concrete repairs for a minimum of 21 days.
- Do not use silane material after the shelf life date.
- Do not return unused material in opened containers to storage for later use. Either apply such material to appropriate areas on concrete deck surfaces or remove and appropriately dispose of it at offsite locations provided by the Contractor.
- If expansion joints are not being replaced or have been replaced prior to shotblasting, they shall be protected from damage from the shotblasting operation. Deck drains and areas of curb or railing above the proposed surface shall be protected from the shotblasting operation.

HI-0016

BP-26

Robeson County

- Pick up and store all blast media and contaminants in a vacuum unit. Do not create dust during the blasting operation that will obstruct the view of motorists in adjacent roadways. Store, handle, and dispose of blast media and contaminants in accordance with all applicable local, state, and federal requirements.
- Cover deck joint seal and elastomeric material, plug deck drain scuppers, seal cracks on underside of deck, and use other necessary protective measures to prevent leakage of silane below the concrete deck, to protect waterways, bridge components, pedestrians, vehicles, roadway, vegetation, and any other items or areas below or near the bridge.
- Application of sealant by spray methods will not be permitted during windy conditions, if in the opinion of the Engineer, unsatisfactory results will be obtained. Other application methods or rescheduling will be required.
- Avoid application with hand pump sprayers. For small areas of silane application, the use of hand pump sprayers might be allowed, but must be approved by the Engineer.
- Protect traffic from rebound, dust, overspray, and construction activities. Provide appropriate shielding, as required and/or directed by the Engineer.
- The Contractor shall provide suitable coverings (e.g. heavy-duty drop cloths) as needed to protect all exposed areas not to receive silane treatment, such as asphalt pavement, curbs, sidewalks, parapets, etc.
- Clean and/or repair all damage or defacement resulting from Contractor's operations to the Engineer's satisfaction at no additional cost to the Department.
- The equipment used for silane application must be clean of foreign materials and approved by the Engineer before use.
- The surface to receive the treatment shall be dry for at least 48 hours before treatment and shall be free from sand, surface dust and dirt, oil, grease, chemical films, and other contaminants prior to application of the silane.
- The surface, air, and material temperatures shall be between 40°F and 90°F during application.
- Do not apply silane materials during cold, hot, or wet weather conditions or when adverse weather conditions are forecast within twelve (12) hours of the completion of the silane application. Correct any coating damaged by rain or moisture by an additional application or as required by the silane manufacturer.
- Protect prepared surfaces from precipitation and heavy dew during and after the application of the silane.
- Conduct the work in a continuous operation, with the silane application as soon as practical following surface preparation.
- Apply silane during the lowest temperature period of the day, typically between 1:00 a.m. and 9:00 a.m., when the cracks are open to the greatest extent.
- Clean up, dispose of any surplus material, and restore any disturbed areas unless otherwise directed.
- 100% Silane is a combustible liquid; take appropriate precautions during handling, storage, and operations. **KEEP AWAY FROM OPEN FLAME.**
- Work crews should wear appropriate personal protection equipment and follow manufacturer's recommendations when applying silane. Refer to the SDS and all applicable local, state, and federal laws, and rules and regulations of authorities having jurisdiction over the project, for specific guidance for personal and environmental protection and safety requirements.

MEASUREMENT AND PAYMENT

Shotblasting Bridge Deck will be measured and paid for at the contract unit price per square yard and

HI-0016

BP-27

Robeson County

will be full compensation for the shotblasting and necessary sandblasting and handwork to prepare the entire concrete bridge deck, and removal and disposal of all waste material generated.

Silane Deck Treatment will be measured and paid for at the contract unit price per square yard and will be full compensation for bridge deck surface and crack preparation; for furnishing and applying the silane deck treatment; for protection of waterways, bridge, and other nearby surfaces, vehicles, and pedestrians; and for all labor, tools, and incidentals necessary to complete the work.

Payment will be made under:

Pay Item	Pay Unit
Shotblasting Bridge Deck	Square Yard
Silane Deck Treatment	Square Yard

SILANE BARRIER RAIL TREATMENT

(SPECIAL)

DESCRIPTION

This work consists of preparation of bridge concrete barrier rail surfaces and the furnishing and application of alkylalkoxysilane (silane) penetrant sealers, with 100% solids, to seal bridge concrete barrier rail surfaces and cracks. Prepare the bridge concrete barrier rail surfaces and apply the silane bridge concrete barrier rail sealer in accordance with this special provision and as indicated on the plans, or as approved by the Engineer.

Work includes: bridge concrete barrier rail surface preparation, placement of silane penetrant sealer, appropriate removal and disposal of excess and waste material, and any incidentals necessary to complete the project, as specified or as indicated on the plans.

SUBMITTALS

Submit for approval the following requested items and any other relevant documents:

- (A) A safety data sheet (SDS) for each shipment of the silane materials.
- (B) Silane material information and manufacturer's written preparation and application instructions.
- (C) Certification from an independent testing laboratory that the materials meet the requirements of these provisions. Do not incorporate these materials into the project until the Engineer has accepted and approved the certification for the material.
- (D) The dates of manufacture of the silane materials, their lot numbers and date of shelf-life expiration for each lot number.
- (E) A table indicating the likely cure time, in minutes, to allow vehicular traffic on the bridge where the concrete barrier rail surface has been treated. Provide time for the allowable ambient temperature range, in increments of 10° F.
- (F) A work plan for each structure that includes estimated times for surface preparation and silane application.

MATERIAL DELIVERY AND STORAGE

Store at the site sufficient quantities of silane materials to perform the entire application.

Deliver materials in manufacturer's original, unopened, undamaged containers with identification labels intact. Ensure that each container is clearly marked by the manufacturer with the following information:

HI-0016

BP-28

Robeson County

- (A) Manufacturer's name and address.
- (B) Product name.
- (C) Date of manufacture.
- (D) Expiration date.
- (E) Lot identification number.
- (F) Container serial number.

Provide the Engineer a certification from the manufacturer, confirming that the silane materials meet the requirements of this special provision. Do not incorporate these materials into the project until the Engineer has accepted and approved the certification for the material. Submit such certification for each lot of material delivered to the project. In each certification, identify the serial or lot numbers of the containers certified.

The Engineer may require samples from each lot or container of materials delivered to the project or from containers at the point of use. When samples are required, furnish samples in accordance with the Engineer's instructions.

Store silane materials in unopened containers in a clean, dry area between 40° F and 90° F. Store containers in a manner that prevents leakage or spillage.

MANUFACTURER'S REPRESENTATIVE

Provide a manufacturer's representative on site for the duration of the surface preparation and silane application work, to provide expert assistance on surface preparation, storage, mixing, application, clean-up, and disposal of materials.

MATERIALS

Provide silane from a single manufacturer, and provide silane that conforms to requirements indicated in Table 1, below.

**Table 1
SILANE PROPERTIES**

Property	Test Method	Requirement
Silane Content		100%
VOC content	EPA method 24	Less than 350 g/l
Surface Appearance after Application		Unchanged
Flash Point	ASTM D3278	140° F, minimum
Resistance to Chloride Ion Penetration	AASHTO T259 and T260	Less than: 0.52 pounds/yd ³ (criteria of 1.5) at 1/2 inch level; 0.00 pounds/yd ³ (criteria of 0.75) at 1 inch level
Water absorption test	ASTM C 642	0.50% maximum/48 hours; 1.5% maximum/50 days
Scaling resistance	ASTM C 672	(non-air-entrained concrete) 0 rating "No Scaling" (100 cycles)
NCHRP 244		

HI-0016

BP-29

Robeson County

Water weight gain	Series II - cube test	85% reduction, minimum
Absorbed chloride		87% reduction, minimum
Absorbed chloride	Series IV - Southern climate	95% reduction, minimum

SURFACE PREPARATION

Prepare the bridge concrete barrier rail surfaces for application of the silane in order to remove all existing grease, slurry, oils, paint, dirt, striping, curing compound, rust, membrane, weak surface mortar, or any other contaminants that could interfere with the proper adhesion, penetration, and the curing of the silane material.

Prepare a final surface that adheres to the following requirements:

- (A) For areas to receive silane treatment, clean by sandblasting or shotblasting. Select the size of shot or sand, and travel speed of the equipment to provide a uniformly clean surface with a uniform profile. Do not expose cleaned surfaces to vehicular traffic unless approved by the Engineer. If the bridge concrete barrier rail surfaces become contaminated before placing the silane treatment, shotblast or abrasive sandblast the contaminated areas to the satisfaction of the Engineer, at no additional cost.
- (B) Power washing of the bridge concrete barrier rail may be allowed as approved by the Engineer, but the concrete barrier shall be allowed to dry a minimum of 48 hours prior to application of the silane treatment.
- (C) Prior to silane application, protect cracks on the bridge concrete barrier rail from materials that can interfere with the penetration and the curing of the silane material. Just prior to placement of the silane, remove, by magnets and oil-free compressed air and vacuuming, any loose particles, such that no excess particles remain.
- (D) Prior to silane application, the bridge concrete barrier rail shall be completely dry.
- (E) The silane manufacturer may suggest cleaning and preparation methods other than those detailed by this special provision. The Engineer must approve such alternative methods prior to implementation.

SILANE APPLICATION**(A) Test Area**

- (1) Test a small area of the surface (minimum 2 ft. by 2 ft.) before general application to ensure desired performance results, aesthetics, and application rates and to verify application technique. Allow 5–7 days for the product to react fully before evaluating.
- (2) Application rates may vary depending on field conditions and the substrate to be treated.
- (3) Conduct at least one absorption test in the test area, using a Rilem Tube Test. Acceptable results are no loss of water in the Rilem tube over a period of 20 minutes. Adjust application to achieve required repellent performance.
- (4) The manufacturer's representative shall assist the Contractor in determining the application rates. Use test applications on actual surfaces to determine accurate application rates. Extremely porous surfaces may require two (2) coats of silane.
- (5) Do not begin production application of silane until Engineer has approved the test area, including approval of aesthetics, color, texture, and appearance.

HI-0016

BP-30

Robeson County

(B) Application

Immediately before placing silane, all exposed surfaces shall be completely dry and blown clean with oil-free compressed air to remove any loose dust and debris. Apply silane as soon as practical after the exposed surfaces have been properly prepared and conditions are satisfactory:

- (1) Stir material thoroughly before and during application.
- (2) Apply silane using low-pressure pumping equipment with a wet fan type spray nozzle. Rollers with a 1" nap or brushes are permitted. On vertical surfaces, apply the silane in a flooding application from the bottom upward, in accordance with manufacturer's instructions.
- (3) Maintain operating pressures in sprayers used for application of the silane sealer material sufficiently low, so that atomization or misting of the material does not occur.
- (4) Apply even distribution of silane. Take care when applying the silane, so that running or ponding does not occur.
- (5) Apply silane in a single application to the barrier rail surface with enough material to saturate the surface. Remove excess material with a roller or brush and dispose of excess material appropriately. If a second coat is required, it should be applied "wet on wet" before first coat dries.
- (6) Application of sealant by spray methods will not be permitted when wind speeds are 20 mph or more, or if in the opinion of the Engineer, unsatisfactory results will be obtained. Other application methods or rescheduling will be required.
- (7) Avoid application with hand pump sprayers. For small areas of silane application, the use of hand pump sprayers must be approved by the Engineer.
- (8) Contractor shall protect from overspray all pedestrians, vehicles, plants and vegetation, and other areas not receiving silane application. Damages that occur due to overspray shall be the responsibility of the Contractor.
- (9) Allow product to penetrate the bridge concrete barrier rail and dry, as required by the manufacturer, prior to opening to traffic.

LIMITATIONS OF OPERATIONS

- (1) Prior to application of any silane sealer, cure concrete or concrete repairs for a minimum of 28 days or as required by the silane manufacturer.
- (2) Do not use silane material after the shelf life date.
- (3) Do not return unused material in opened containers to storage for later use. Either apply such material to appropriate areas on barrier rail surfaces or remove and appropriately dispose of it at offsite locations provided by the Contractor.
- (4) Pick up and store all blast media and contaminants in a vacuum unit. Do not create dust during the blasting operation that will obstruct the view of motorists in roadways adjacent, above, below, or surrounding the silane treatment area. Store, handle, and dispose of blast media and contaminants in accordance with all applicable local, state, and federal requirements.
- (5) Cover deck joint seal and elastomeric material, plug deck drain scuppers, seal cracks on underside of deck, and use other necessary protective measures to prevent leakage of silane below the concrete deck and beyond the concrete barrier rail, to protect waterways, bridge components, pedestrians, vehicles, roadway, vegetation, and any other items or areas below or near the bridge.
- (6) Application of sealant by spray methods will not be permitted during windy conditions, if in the opinion of the Engineer, unsatisfactory results will be obtained. Other application methods or rescheduling will be required.
- (7) Avoid application with hand pump sprayers. For small areas of silane application, the use of hand pump sprayers might be allowed, but must be approved by the Engineer.

HI-0016

BP-31

Robeson County

- (8) Protect traffic from rebound, dust, overspray, and construction activities. Provide appropriate shielding, as required and/or directed by the Engineer. Damages that occur due to the Contractor's operations shall be the responsibility of the Contractor.
- (9) The Contractor shall provide suitable coverings (e.g. heavy-duty drop cloths) as needed to protect all exposed areas not to receive surface preparation and silane treatment.
- (10) Clean and/or repair all damage or defacement resulting from Contractor's operations to the Engineer's satisfaction at no additional cost to the Department.
- (11) The equipment used for silane application must be clean of foreign materials and approved by the Engineer before use.
- (12) The surface to receive the treatment shall be dry for at least 48 hours before treatment and shall be free from sand, surface dust and dirt, oil, grease, chemical films, and other contaminants prior to application of the silane.
- (13) The surface, air, and material temperatures shall be between 40°F and 90°F during application.
- (14) Do not apply silane materials during cold, hot, or wet weather conditions or when adverse weather conditions are forecasted within 12 hours of the completion of the silane application. Correct any coating damaged by rain or moisture by an additional application or as required by the silane manufacturer.
- (15) Protect prepared surfaces from precipitation and heavy dew during and after the application of the silane.
- (16) Conduct the work in a continuous operation, with the silane application as soon as practical following surface preparation.
- (17) Apply silane during the lowest temperature period of the day, typically between 1:00 a.m. and 9:00 a.m., when the cracks are open to the greatest extent.
- (18) Clean up, dispose of any surplus material, and restore any disturbed areas unless otherwise directed.
- (19) 100% Silane is a combustible liquid; take appropriate precautions during handling, storage, and operations. **KEEP AWAY FROM OPEN FLAME.**
- (20) Work crews should wear appropriate personal protection equipment and follow manufacturer's recommendations when applying silane. Refer to the SDS and all applicable local, state, and federal laws, and rules and regulations of authorities having jurisdiction over the project, for specific guidance for personal and environmental protection and safety requirements.

MEASUREMENT AND PAYMENT

Surface Preparation for Silane Barrier Rail Treatment will be measured and paid for at the contract unit price per square foot and will be full compensation for the shotblasting, sandblasting, or other necessary surface preparation and handwork to prepare the entire bridge concrete barrier rail and removal and disposal of all blast media and waste material generated.

Silane Barrier Rail Treatment will be measured and paid for at the contract unit price per square foot and will be full compensation for bridge concrete barrier rail and crack preparation; for furnishing and applying the silane barrier rail treatment; removal and disposal of excess and waste material generated; for protection of waterways, bridge, and other nearby surfaces, vehicles, and pedestrians; and for all labor, tools, and incidentals necessary to complete the work.

HI-0016

BP-32

Robeson County

Payment will be made under:

Pay Item

Surface Preparation for Silane Barrier Rail Treatment

Silane Barrier Rail Treatment

Pay Unit

Square Foot

Square Foot

**Project Special Provisions
Structures
Table of Contents**

Special Provision		Page
Scope of Work		BP1-2
Submittal of Working Drawings	(2-14-22)	BP1-3
Falsework and Formwork	(2-14-22)	BP1-9
Crane Safety	(6-20-19)	BP1-14
Grout for Structures	(12-1-17)	BP1-15
Concrete Deck Repair for Silane Deck Treatment	(SPECIAL)	BP1-16
Silane Deck Treatment	(SPECIAL)	BP1-17
Silane Barrier Rail Treatment	(SPECIAL)	BP1-23
Bridge Joint Demolition	(SPECIAL)	BP1-28
Elastomeric Concrete for Preservation	(2-11-19)	BP1-29
Foam Joint Seals for Preservation	(SPECIAL)	BP1-32
Repairs to Prestressed Concrete Cored Slabs	(SPECIAL)	BP1-36
Post-Tensioning Strand Replacement	(SPECIAL)	BP1-39
Asphalt Plug Joint for Preservation	(SPECIAL)	BP1-40
Epoxy Resin Injection	(08-08-22)	BP1-46
Shotcrete Repairs	(08-08-22)	BP1-51
Concrete Repairs	(2-11-19)	BP1-55
Volumetric Mixer	(12-18-12)	BP1-58
Special Provisions for Protection of Railroad Interest - CSX Transportation, Inc.		BP1-60



STRUCTURE PROJECT SPECIAL PROVISIONS**SCOPE OF WORK**

This work shall consist of furnishing all labor, equipment, and materials to treat the existing bridge deck and barrier rail with Silane deck treatment, Asphalt Wearing Surface milling and resurfacing on existing cored slabs and complete substructure repairs as directed in the plans. Work includes: portable lighting; existing superstructure bridge deck and barrier rail surface preparation by shotblasting and treating the prepared bridge decks and barrier rail with silane deck treatments, existing joint removal and reconstruction; installation of elastomeric concrete headers and foam joints; Asphalt Wearing Surface milling and resurfacing, replacing post tensioning strands, overlaying the prepared bridge deck with asphalt, and installation Asphalt Plug joint; substructure repair using shotcrete and epoxy resin injection; disposal of demolition and waste material; seeding and mulching all grassed areas disturbed; and all incidental items necessary to complete the project as specified and shown on the plans. No separate measurement or payment will be made for portable lighting. The cost of this work shall be included in the lump sum price bid for Mobilization.

Work will be performed on the existing bridge at the following locations in Robeson County:

1. Bridge #770452 – US74 BYP EB over NC 71
2. Bridge #770453 – US74 BYP WB over NC 71
3. Bridge #770454 - US74 BYP EB over CSX
4. Bridge #770455 – US74 BYP WB over CSX
5. Bridge #770447 – SR1303 over US 74
6. Bridge #770456 – US74 BYP EB over CSX
7. Bridge #770457 – US74 BYP WB over CSX
8. Bridge #770476 – US74 Bus over US 74

The contractor shall provide all necessary access; underdeck platforms, scaffolding, ladders, etc.; provide all traffic control; provide all staging areas, material storage, waste disposal; provide environmental controls to limit loss of materials from sawing equipment, and chipping equipment; and all else necessary to complete the work.

The contractor shall be responsible for fulfilling all requirements of the NCDOT Standard Specifications for Roads and Structures dated January 2018, except as otherwise specified herein.

SUBMITTAL OF WORKING DRAWINGS

(2-14-22)

1.0 GENERAL

Submit working drawings in accordance with Article 105-2 of the *Standard Specifications* and this provision. For this provision, “submittals” refers to only those listed in this provision. The list of submittals contained herein does not represent a list of required submittals for the project. Submittals are only necessary for those items as required by the contract. Make submittals that are not specifically noted in this provision directly to the Engineer. Either the Structures Management Unit or the Geotechnical Engineering Unit or both units will jointly review submittals.

If a submittal contains variations from plan details or specifications or significantly affects project cost, field construction or operations, discuss the submittal with and submit all copies to the Engineer. State the reason for the proposed variation in the submittal. To minimize review time, make sure all submittals are complete when initially submitted. Provide a contact name and information with each submittal. Direct any questions regarding submittal requirements to the Engineer, Structures Management Unit contacts or the Geotechnical Engineering Unit contacts noted below.

To facilitate in-plant inspection by NCDOT and approval of working drawings, provide the name, address and telephone number of the facility where fabrication will actually be done if different than shown on the title block of the submitted working drawings. This includes, but is not limited to, precast concrete items, prestressed concrete items and fabricated steel or aluminum items.

2.0 ADDRESSES AND CONTACTS

For submittals to the Structures Management Unit, use the following addresses:

Via Email: SMU-wdr@ncdot.gov (do not cc SMU Working Drawings staff)

Via US mail:

Mr. B. C. Hanks, P. E.
State Structures Engineer
North Carolina Department
of Transportation
Structures Management Unit
1581 Mail Service Center
Raleigh, NC 27699-1581

Attention: Mr. J. L. Bolden, P. E.

Via other delivery service:

Mr. B. C. Hanks, P. E.
State Structures Engineer
North Carolina Department
of Transportation
Structures Management Unit
1000 Birch Ridge Drive
Raleigh, NC 27610

Attention: Mr. J. L. Bolden, P. E.

For submittals to the Geotechnical Engineering Unit, use the following addresses:

For projects in Divisions 1-7, use the following Eastern Regional Office addresses:

Via Email: EastGeotechnicalSubmittal@ncdot.gov

Via US mail:

Mr. David Hering, L.G., P. E.
Assistant State Geotechnical
Engineer – Eastern Region
North Carolina Department
of Transportation
Geotechnical Engineering Unit
Eastern Regional Office
1570 Mail Service Center
Raleigh, NC 27699-1570

Via other delivery service:

Mr. David Hering, L.G., P. E.
Assistant State Geotechnical
Engineer – Eastern Region
North Carolina Department
of Transportation
Geotechnical Engineering Unit
Eastern Regional Office
3301 Jones Sausage Road, Suite 100
Garner, NC 27529

For projects in Divisions 8-14, use the following Western Regional Office addresses:

Via Email: WestGeotechnicalSubmittal@ncdot.gov

Via US mail or other delivery service:

Mr. Eric Williams, P. E.
Assistant State Geotechnical
Engineer – Western Region
North Carolina Department
of Transportation
Geotechnical Engineering Unit
Western Regional Office
5253 Z Max Boulevard
Harrisburg, NC 28075

The status of the review of structure-related submittals sent to the Structures Management Unit can be viewed from the Unit's website, via the "[Drawing Submittal Status](#)" link.

The status of the review of geotechnical-related submittals sent to the Geotechnical Engineering Unit can be viewed from the Unit's website, via the "[Geotechnical Construction Submittals](#)" link.

Direct any questions concerning submittal review status, review comments or drawing markups to the following contacts:

Primary Structures Contact: James Bolden (919) 707 – 6408
jlbolden@ncdot.gov

Secondary Structures Contacts: Emmanuel Omile (919) 707 – 6451

eomile@ncdot.gov

Madonna Rorie (919) 707 – 6508
mrorie@ncdot.gov

Eastern Regional Geotechnical Contact (Divisions 1-7):
 David Hering (919) 662 – 4710
dthering@ncdot.gov

Western Regional Geotechnical Contact (Divisions 8-14):
 Eric Williams (704) 455 – 8902
ewilliams3@ncdot.gov

3.0 SUBMITTAL COPIES

Furnish one complete copy of each submittal, including all attachments, to the Engineer. At the same time, submit a copy of the same complete submittal directly to the Structures Management Unit and/or the Geotechnical Engineering Unit as specified in the tables below.

The first table below covers “Structure Submittals.” The Engineer will receive review comments and drawing markups for these submittals from the Structures Management Unit. The second table in this section covers “Geotechnical Submittals.” The Engineer will receive review comments and drawing markups for these submittals from the Geotechnical Engineering Unit.

Unless otherwise required, submit one set of supporting calculations to either the Structures Management Unit or the Geotechnical Engineering Unit unless both units require submittal copies in which case submit a set of supporting calculations to each unit. Provide additional copies of any submittal as directed.

STRUCTURE SUBMITTALS

Submittal	Submittal Required by Structures Management Unit?	Submittal Required by Geotechnical Engineering Unit?	Contract Reference Requiring Submittal ¹
Arch Culvert Falsework	Y	N	Plan Note, SN Sheet & “Falsework and Formwork”
Box Culvert Falsework ⁷	Y	N	Plan Note, SN Sheet & “Falsework and Formwork”
Cofferdams	Y	Y	Article 410-4
Foam Joint Seals ⁶	Y	N	“Foam Joint Seals”

HI-0017

BP1-6

Robeson County

Expansion Joint Seals (hold down plate type with base angle)	Y	N	“Expansion Joint Seals”
Expansion Joint Seals (modular)	Y	N	“Modular Expansion Joint Seals”
Expansion Joint Seals (strip seals)	Y	N	“Strip Seal Expansion Joints”
Falsework & Forms ² (substructure)	Y	N	Article 420-3 & “Falsework and Formwork”
Falsework & Forms (superstructure)	Y	N	Article 420-3 & “Falsework and Formwork”
Girder Erection over Railroad	Y	N	Railroad Provisions
Maintenance and Protection of Traffic Beneath Proposed Structure	Y	N	“Maintenance and Protection of Traffic Beneath Proposed Structure at Station ____”
Metal Bridge Railing	Y	N	Plan Note
Metal Stay-in-Place Forms	Y	N	Article 420-3
Metalwork for Elastomeric Bearings ^{4,5}	Y	N	Article 1072-8
Miscellaneous Metalwork ^{4,5}	Y	N	Article 1072-8
Disc Bearings ⁴	Y	N	“Disc Bearings”
Overhead and Digital Message Signs (DMS) (metalwork and foundations)	Y	N	Applicable Provisions
Placement of Equipment on Structures (cranes, etc.)	Y	N	Article 420-20
Prestressed Concrete Box Beam (detensioning sequences) ³	Y	N	Article 1078-11
Precast Concrete Box Culverts	Y	N	“Optional Precast Reinforced Concrete Box Culvert at Station ____”
Prestressed Concrete Cored Slab (detensioning sequences) ³	Y	N	Article 1078-11
Prestressed Concrete Deck Panels	Y	N	Article 420-3

HI-0017

BP1-7

Robeson County

Prestressed Concrete Girder (strand elongation and detensioning sequences)	Y	N	Articles 1078-8 and 1078- 11
Removal of Existing Structure over Railroad	Y	N	Railroad Provisions
Revised Bridge Deck Plans (adaptation to prestressed deck panels)	Y	N	Article 420-3
Revised Bridge Deck Plans (adaptation to modular expansion joint seals)	Y	N	“Modular Expansion Joint Seals”
Sound Barrier Wall (precast items)	Y	N	Article 1077-2 & “Sound Barrier Wall”
Sound Barrier Wall Steel Fabrication Plans ⁵	Y	N	Article 1072-8 & “Sound Barrier Wall”
Structural Steel ⁴	Y	N	Article 1072-8 Article 400-3 & “Construction, Maintenance and Removal of Temporary Structure at Station _____”
Temporary Detour Structures	Y	Y	
TFE Expansion Bearings ⁴	Y	N	Article 1072-8

FOOTNOTES

- References are provided to help locate the part of the contract where the submittals are required. References in quotes refer to the provision by that name. Articles refer to the *Standard Specifications*.
- Submittals for these items are necessary only when required by a note on plans.
- Submittals for these items may not be required. A list of pre-approved sequences is available from the producer or the Materials & Tests Unit.
- The fabricator may submit these items directly to the Structures Management Unit.
- The two sets of preliminary submittals required by Article 1072-8 of the *Standard Specifications* are not required for these items.
- Submittals for Fabrication Drawings are not required. Submittals for Catalogue Cuts of Proposed Material are required. See Section 5.A of the referenced provision.
- Submittals are necessary only when the top slab thickness is 18” or greater.

GEOTECHNICAL SUBMITTALS

Submittal	Submittals Required by Geotechnical Engineering Unit	Submittals Required by Structures Management Unit	Contract Reference Requiring Submittal ¹
Drilled Pier Construction Plans ²	Y	N	Subarticle 411-3(A)
Crosshole Sonic Logging (CSL) Reports ²	Y	N	Subarticle 411-5(A)(2)
Pile Driving Equipment Data Forms ^{2,3}	Y	N	Subarticle 450-3(D)(2)
Pile Driving Analyzer (PDA) Reports ²	Y	N	Subarticle 450-3(F)(3)
Retaining Walls ⁴	Y; drawings and calculations	Y; drawings	Applicable Provisions
Temporary Shoring ⁴	Y; drawings and calculations	Y; drawings	“Temporary Shoring” & “Temporary Soil Nail Walls”

FOOTNOTES

1. References are provided to help locate the part of the contract where the submittals are required. References in quotes refer to the provision by that name. Subarticles refer to the *Standard Specifications*.
2. Submit one hard copy of submittal to the Engineer. Submit a second copy of submittal electronically (PDF via email), US mail or other delivery service to the appropriate Geotechnical Engineering Unit regional office. Electronic submission is preferred.
3. The Pile Driving Equipment Data Form is available from:
https://connect.ncdot.gov/resources/Geological/Pages/Geotech_Forms_Details.aspx
 See second page of form for submittal instructions.
4. Electronic copy of submittal is required. See referenced provision.

FALSEWORK AND FORMWORK**(2-14-22)****1.0 DESCRIPTION**

Use this Special Provision as a guide to develop temporary works submittals required by the Standard Specifications or other provisions; no additional submittals are required herein. Such temporary works include, but are not limited to, falsework and formwork.

Falsework is any temporary construction used to support the permanent structure until it becomes self-supporting. Formwork is the temporary structure or mold used to retain plastic or fluid concrete in its designated shape until it hardens. Access scaffolding is a temporary structure that functions as a work platform that supports construction personnel, materials, and tools, but is not intended to support the structure. Scaffolding systems that are used to temporarily support permanent structures (as opposed to functioning as work platforms) are considered to be falsework under the definitions given. Shoring is a component of falsework such as horizontal, vertical, or inclined support members. Where the term “temporary works” is used, it includes all of the temporary facilities used in bridge construction that do not become part of the permanent structure.

Design and construct safe and adequate temporary works that will support all loads imposed and provide the necessary rigidity to achieve the lines and grades shown on the plans in the final structure.

2.0 MATERIALS

Select materials suitable for temporary works; however, select materials that also ensure the safety and quality required by the design assumptions. The Engineer has authority to reject material on the basis of its condition, inappropriate use, safety, or nonconformance with the plans. Clearly identify allowable loads or stresses for all materials or manufactured devices on the plans. Revise the plan and notify the Engineer if any change to materials or material strengths is required.

3.0 DESIGN REQUIREMENTS**A. Working Drawings**

Provide working drawings for items as specified in the contract, or as required by the Engineer, with design calculations and supporting data in sufficient detail to permit a structural and safety review of the proposed design of the temporary work.

On the drawings, show all information necessary to allow the design of any component to be checked independently as determined by the Engineer.

When concrete placement is involved, include data such as the drawings of proposed sequence, rate of placement, direction of placement, and location of all construction joints.

When required, have the drawings and calculations prepared under the guidance of, and sealed by, a North Carolina Registered Professional Engineer who is knowledgeable in temporary works design.

If requested by the Engineer, submit with the working drawings manufacturer's catalog data listing the weight of all construction equipment that will be supported on the temporary work. Show anticipated total settlements and/or deflections of falsework and forms on the working drawings. Include falsework footing settlements, joint take-up, and deflection of beams or girders.

As an option for the Contractor, overhang falsework hangers may be uniformly spaced, at a maximum of 36 inches, provided the following conditions are met:

Member Type (PCG)	Member Depth, (inches)	Max. Overhang Width, (inches)	Max. Slab Edge Thickness, (inches)	Max. Screed Wheel Weight, (lbs.)	Bracket Min. Vertical Leg Extension, (inches)
II	36	39	14	2000	26
III	45	42	14	2000	35
IV	54	45	14	2000	44
MBT	63	51	12	2000	50
MBT	72	55	12	1700	48

Overhang width is measured from the centerline of the girder to the edge of the deck slab. For Type II, III & IV prestressed concrete girders (PCG), 45-degree cast-in-place half hangers and rods must have a minimum safe working load of 6,000 lbs.

For MBT prestressed concrete girders, 45-degree angle holes for falsework hanger rods shall be cast through the girder top flange and located, measuring along the top of the member, 1'-2 1/2" from the edge of the top flange. Hanger hardware and rods must have a minimum safe working load of 6,000 lbs.

For links slabs, the tops of girders directly beneath the link slab shall be free of overhang falsework attachments or other hardware. Submit calculations and working drawings for overhang falsework in the link slab region.

The overhang bracket provided for the diagonal leg shall have a minimum safe working load of 3,750 lbs. The vertical leg of the bracket shall extend to the point that the heel bears on the girder bottom flange, no closer than 4 inches from the bottom of the member. However, for 72-inch members, the heel of the bracket shall bear on the web, near the bottom flange transition.

Provide adequate overhang falsework and determine the appropriate adjustments for deck geometry, equipment, casting procedures and casting conditions.

If the optional overhang falsework spacing is used, indicate this on the falsework submittal and advise the girder producer of the proposed details. Failure to notify the

Engineer of hanger type and hanger spacing on prestressed concrete girder casting drawings may delay the approval of those drawings.

Falsework hangers that support concentrated loads and are installed at the edge of thin top flange concrete girders (such as bulb tee girders) shall be spaced so as not to exceed 75% of the manufacturer’s stated safe working load. Use of dual leg hangers (such as Meadow Burke HF-42 and HF-43) are not allowed on concrete girders with thin top flanges. Design the falsework and forms supporting deck slabs and overhangs on girder bridges so that there will be no differential settlement between the girders and the deck forms during placement of deck concrete.

When staged construction of the bridge deck is required, detail falsework and forms for screed and fluid concrete loads to be independent of any previous deck pour components when the mid-span girder deflection due to deck weight is greater than 3/4”.

Note on the working drawings any anchorages, connectors, inserts, steel sleeves or other such devices used as part of the falsework or formwork that remains in the permanent structure. If the plan notes indicate that the structure contains the necessary corrosion protection required for a Corrosive Site, epoxy coat, galvanize or metalize these devices. Electroplating will not be allowed. Any coating required by the Engineer will be considered incidental to the various pay items requiring temporary works.

Design falsework and formwork requiring submittals in accordance with the 1995 AASHTO *Guide Design Specifications for Bridge Temporary Works* except as noted herein.

1. Wind Loads

Table 2.2 of Article 2.2.5.1 is modified to include wind velocities up to 110 mph. In addition, Table 2.2A is included to provide the maximum wind speeds by county in North Carolina.

Table 2.2 - Wind Pressure Values

Height Zone feet above ground	Pressure, lb/ft ² for Indicated Wind Velocity, mph				
	70	80	90	100	110
0 to 30	15	20	25	30	35
30 to 50	20	25	30	35	40
50 to 100	25	30	35	40	45
over 100	30	35	40	45	50

2. Time of Removal

The following requirements replace those of Article 3.4.8.2.

Do not remove forms until the concrete has attained strengths required in Article 420-16 of the Standard Specifications and these Special Provisions.

Do not remove forms until the concrete has sufficient strength to prevent damage to the surface.

Table 2.2A - Steady State Maximum Wind Speeds by Counties in North Carolina

COUNTY	25 YR (mph)	COUNTY	25 YR (mph)	COUNTY	25 YR (mph)
Alamance	70	Franklin	70	Pamlico	100
Alexander	70	Gaston	70	Pasquotank	100
Alleghany	70	Gates	90	Pender	100
Anson	70	Graham	80	Perquimans	100
Ashe	70	Granville	70	Person	70
Avery	70	Greene	80	Pitt	90
Beaufort	100	Guilford	70	Polk	80
Bertie	90	Halifax	80	Randolph	70
Bladen	90	Harnett	70	Richmond	70
Brunswick	100	Haywood	80	Robeson	80
Buncombe	80	Henderson	80	Rockingham	70
Burke	70	Hertford	90	Rowan	70
Cabarrus	70	Hoke	70	Rutherford	70
Caldwell	70	Hyde	110	Sampson	90
Camden	100	Iredell	70	Scotland	70
Carteret	110	Jackson	80	Stanley	70
Caswell	70	Johnston	80	Stokes	70
Catawba	70	Jones	100	Surry	70
Cherokee	80	Lee	70	Swain	80
Chatham	70	Lenoir	90	Transylvania	80
Chowan	90	Lincoln	70	Tyrell	100
Clay	80	Macon	80	Union	70
Cleveland	70	Madison	80	Vance	70
Columbus	90	Martin	90	Wake	70
Craven	100	McDowell	70	Warren	70
Cumberland	80	Mecklenburg	70	Washington	100
Currituck	100	Mitchell	70	Watauga	70
Dare	110	Montgomery	70	Wayne	80
Davidson	70	Moore	70	Wilkes	70
Davie	70	Nash	80	Wilson	80
Duplin	90	New Hanover	100	Yadkin	70

Durham	70	Northampton	80	Yancey	70
Edgecombe	80	Onslow	100		
Forsyth	70	Orange	70		

B. Review and Approval

The Engineer is responsible for the review and approval of temporary works' drawings.

Submit the working drawings sufficiently in advance of proposed use to allow for their review, revision (if needed), and approval without delay to the work.

The time period for review of the working drawings does not begin until complete drawings and design calculations, when required, are received by the Engineer.

Do not start construction of any temporary work for which working drawings are required until the drawings have been approved. Such approval does not relieve the Contractor of the responsibility for the accuracy and adequacy of the working drawings.

4.0 CONSTRUCTION REQUIREMENTS

All requirements of Section 420 of the Standard Specifications apply.

Construct temporary works in conformance with the approved working drawings. Ensure that the quality of materials and workmanship employed is consistent with that assumed in the design of the temporary works. Do not weld falsework members to any portion of the permanent structure unless approved. Show any welding to the permanent structure on the approved construction drawings.

Provide tell-tales attached to the forms and extending to the ground, or other means, for accurate measurement of falsework settlement. Make sure that the anticipated compressive settlement and/or deflection of falsework does not exceed 1 inch. For cast-in-place concrete structures, make sure that the calculated deflection of falsework flexural members does not exceed 1/240 of their span regardless of whether or not the deflection is compensated by camber strips.

A. Maintenance and Inspection

Inspect and maintain the temporary work in an acceptable condition throughout the period of its use. Certify that the manufactured devices have been maintained in a condition to allow them to safely carry their rated loads. Clearly mark each piece so that its capacity can be readily determined at the job site.

Perform an in-depth inspection of an applicable portion(s) of the temporary works, in the presence of the Engineer, not more than 24 hours prior to the beginning of each concrete placement. Inspect other temporary works at least once a month to ensure that they are

functioning properly. Have a North Carolina Registered Professional Engineer inspect the cofferdams, shoring, sheathing, support of excavation structures, and support systems for load tests prior to loading.

B. Foundations

Determine the safe bearing capacity of the foundation material on which the supports for temporary works rest. If required by the Engineer, conduct load tests to verify proposed bearing capacity values that are marginal or in other high-risk situations.

The use of the foundation support values shown on the contract plans of the permanent structure is permitted if the foundations are on the same level and on the same soil as those of the permanent structure.

Allow for adequate site drainage or soil protection to prevent soil saturation and washout of the soil supporting the temporary works supports.

If piles are used, the estimation of capacities and later confirmation during construction using standard procedures based on the driving characteristics of the pile is permitted. If preferred, use load tests to confirm the estimated capacities; or, if required by the Engineer conduct load tests to verify bearing capacity values that are marginal or in other high risk situations.

The Engineer reviews and approves the proposed pile and soil bearing capacities.

5.0 REMOVAL

Unless otherwise permitted, remove and keep all temporary works upon completion of the work. Do not disturb or otherwise damage the finished work.

Remove temporary works in conformance with the contract documents. Remove them in such a manner as to permit the structure to uniformly and gradually take the stresses due to its own weight.

6.0 METHOD OF MEASUREMENT

Unless otherwise specified, temporary works will not be directly measured.

7.0 BASIS OF PAYMENT

Payment at the contract unit prices for the various pay items requiring temporary works will be full compensation for the above falsework and formwork.

CRANE SAFETY

(6-20-19)

Comply with the manufacturer specifications and limitations applicable to the operation of any and all cranes and derricks. Prime contractors, sub-contractors, and fully operated rental

companies shall comply with the current Occupational Safety and Health Administration (OSHA) regulations.

Submit all items listed below to the Engineer prior to beginning crane operations. Changes in personnel or equipment must be reported to the Engineer and all applicable items listed below must be updated and submitted prior to continuing with crane operations.

CRANE SAFETY SUBMITTAL LIST

- A. **Competent Person:** Provide the name and qualifications of the “Competent Person” responsible for crane safety and lifting operations. The named competent person will have the responsibility and authority to stop any work activity due to safety concerns.
- B. **Riggers:** Provide the qualifications and experience of the persons responsible for rigging operations. Qualifications and experience should include, but not be limited to, weight calculations, center of gravity determinations, selection and inspection of sling and rigging equipment, and safe rigging practices.
- C. **Crane Inspections:** Inspection records for all cranes shall be current and readily accessible for review upon request.
- D. **Certifications:** Crane operators shall be certified by the National Commission for the Certification of Crane Operators (NCCCO) or the National Center for Construction Education and Research (NCCER). Other approved nationally accredited programs will be considered upon request. In addition, crane operators shall have a current CDL medical card. Submit a list of crane operator(s) and include current certification for each type of crane operated (small hydraulic, large hydraulic, small lattice, large lattice) and medical evaluations for each operator.

GROUT FOR STRUCTURES

(12-1-17)

DESCRIPTION

This special provision addresses grout for use in pile blockouts, grout pockets, shear keys, dowel holes and recesses for structures. This provision does not apply to grout placed in post-tensioning ducts for bridge beams, girders, decks, end bent caps, or bent caps. Mix and place grout in accordance with the manufacturer’s recommendations, the applicable sections of the Standard Specifications and this provision.

MATERIAL REQUIREMENTS

Unless otherwise noted on the plans, use a Type 3 Grout in accordance with Section 1003 of the Standard Specifications.

Initial setting time shall not be less than 10 minutes when tested in accordance with ASTM C266.

Construction loading and traffic loading shall not be allowed until the 3 day compressive strength is achieved.

SAMPLING AND PLACEMENT

Place and maintain components in final position until grout placement is complete and accepted. Concrete surfaces to receive grout shall be free of defective concrete, laitance, oil, grease and other foreign matter. Saturate concrete surfaces with clean water and remove excess water prior to placing grout.

BASIS OF PAYMENT

No separate payment will be made for "Grout for Structures". The cost of the material, equipment, labor, placement, and any incidentals necessary to complete the work shall be considered incidental to the structure item requiring grout.

CONCRETE DECK REPAIR FOR SILANE DECK TREATMENT (SPECIAL)

GENERAL

This special provision addresses concrete deck repairs prior to placing silane deck treatment. Work shall begin within 60 days of notification. After surface preparation, the Engineer sounds the deck using a chain drag or other acceptable means and marks areas to be repaired.

MATERIALS

Concrete deck repair material shall be epoxy-based material listed as a Type 2 epoxy resin system on the NCDOT Approved Product List (APL) and approved by the silane deck treatment manufacturer for use with the proposed silane deck treatment system. Concrete deck repair material shall attain a minimum compressive strength of 4,500 psi within 3 hours. Proportioning, aggregates, mixing, and curing of the epoxy-based repair material shall follow all manufacturer's requirements.

Materials containing cement mortar may be acceptable; however, a 28 day curing period will be required before placing the silane deck treatment. The curing period may be adjusted if approved by the silane manufacturer and the Engineer. If repair materials containing cement mortar are proposed, they shall meet the following requirements:

Furnish Department approved pre-packaged concrete or bulk concrete materials in a mix proportioned to satisfy provisions for Class AA Concrete detailed in Article 1000-4 of the *Standard Specifications* or as otherwise noted in the Concrete for Deck Repair special provision.

CLASS II SURFACE PREPARATION (PARTIAL DEPTH)

Saw cut a perimeter surrounding the repair to a depth not less than 1 inch and remove all loose, unsound and contaminated material by chipping with hand tools to an average depth of approximately one-half the deck thickness, but no less $\frac{3}{4}$ " below the top mat of steel. Clean, repair,

or replace rusted or loose reinforcing steel. Care shall be taken not to cut, stretch, or damage any exposed reinforcing steel. Thoroughly clean the newly exposed surface. Use a bonding agent in accordance with the manufacturer’s recommendations.

PLACEMENT AND FINISHING

Place concrete for deck repair at locations indicated on the plans that have been properly prepared as required in the subsection “Class II Surface Preparation (Partial Depth)” unless otherwise required by the repair material manufacturer or allowed by the Engineer, place, consolidate, finish, and cure concrete deck repair material in accordance with Section 420 of the *Standard Specifications*. For small deck areas (less than 16 sq. ft.) finish surface by tining to a depth of ¼” in a pattern similar to the existing grooving pattern.

MEASUREMENT & PAYMENT

Concrete Deck Repair for Silane Deck Treatment will be measured and paid for at the contract unit price per square feet for the appropriate areas repaired. The price shall include materials, labor, equipment, tools and any incidentals necessary to complete the work.

Payment will be made under:

Pay Item	Pay Unit
Concrete Deck Repair for Silane Deck Treatment	Square Feet

SILANE DECK TREATMENT **(SPECIAL)**

DESCRIPTION

This work consists of preparation of concrete bridge deck surfaces and the furnishing and application of alkylalkoxysilane (silane) penetrant sealers, with 100% solids, to seal bridge deck surfaces and cracks. Prepare the surface of the concrete deck and apply the silane bridge deck sealer in accordance with this special provision and as indicated on the plans, or as approved by the Engineer.

Work includes: bridge deck surface preparation, placement of silane deck sealer, and any incidentals necessary to complete the project, as specified or as indicated on the plans.

SUBMITTALS

Submit for approval the following requested items and any other relevant documents:

- (A) A safety data sheet (SDS) for each shipment of the silane materials.
- (B) Silane material information and manufacturer’s written preparation and application instructions.
- (C) Certification from an independent testing laboratory that the materials meet the requirements of these provisions. Do not incorporate these materials into the project until the Engineer has accepted and approved the certification for the material.

- (D) The dates of manufacture of the silane materials, their lot numbers and date of shelf-life expiration for each lot number.
- (E) A table indicating the likely cure time, in minutes, to allow vehicular traffic on the silane-treated deck surface. Provide time for the allowable ambient temperature range, in increments of 10° F (6° C).
- (F) A work plan for each structure that includes estimated times for surface preparation and silane application.

MATERIAL DELIVERY AND STORAGE

Store at the site sufficient quantities of silane materials to perform the entire application.

Deliver materials in manufacturer's original, unopened, undamaged containers with identification labels intact. Ensure that each container is clearly marked by the manufacturer with the following information:

- (A) Manufacturer's name and address.
- (B) Product name.
- (C) Date of manufacture.
- (D) Expiration date.
- (E) Lot identification number.
- (F) Container serial number.

Provide the Engineer a certification from the manufacturer, confirming that the silane materials meet the requirements of this special provision. Do not incorporate these materials into the project until the Engineer has accepted and approved the certification for the material. Submit such certification for each lot of material delivered to the project. In each certification, identify the serial or lot numbers of the containers certified.

The Engineer may require samples from each lot or container of materials delivered to the project or from containers at the point of use. When samples are required, furnish samples in accordance with the Engineer's instructions.

Store silane materials in unopened containers in a clean, dry area between 40° F and 90° F. Store containers in a manner that prevents leakage or spillage.

MANUFACTURER'S REPRESENTATIVE

Provide a manufacturer's representative on site for the duration of the surface preparation and silane application work, to provide expert assistance on surface preparation, storage, mixing, application, clean-up, and disposal of materials.

MATERIALS

Provide silane from a single manufacturer and provide silane that conforms to requirements indicated in Table 1, below.

**Table 1
SILANE PROPERTIES**

Property	Test Method	Requirement
Silane Content		100%
VOC content	EPA method 24	Less than 350 g/l
Surface Appearance after Application		Unchanged
Flash Point	ASTM D3278	140° F, minimum
Resistance to Chloride Ion Penetration	AASHTO T259 and T260	Less than: 0.52 pounds/yd ³ (criteria of 1.5) at 1/2 inch level; 0.00 pounds/yd ³ (criteria of 0.75) at 1 inch level
Water absorption test	ASTM C 642	0.50% maximum/48 hours; 1.5% maximum/50 days
Scaling resistance	ASTM C 672	(non-air-entrained concrete) 0 rating “No Scaling” (100 cycles)
NCHRP 244		
Water weight gain	Series II - cube test	85% reduction, minimum
Absorbed chloride		87% reduction, minimum
Absorbed chloride	Series IV - Southern climate	95% reduction, minimum

SURFACE PREPARATION

Prepare the surface of the concrete deck for application of the silane by shotblasting in order to remove all existing grease, slurry, oils, paint, dirt, striping, curing compound, rust, membrane, weak surface mortar, or any other contaminants that could interfere with the proper adhesion, penetration, and the curing of the silane material.

Prepare a final surface that adheres to the following requirements:

- (A) For areas to receive deck seal treatment, clean by shotblasting. Where approved by the Engineer, abrasive sandblasting may be used in areas that cannot be accessed by the shotblaster. Select the size of shot or sand, and travel speed of the equipment to provide a uniformly clean surface with a uniform profile. Remove striping to the maximum extent determined to be practical by the Engineer using up to three passes with shotblasting, sandblasting, or other approved equipment. Do not expose cleaned surfaces to vehicular traffic unless approved by the Engineer. If the deck becomes contaminated before placing the silane deck sealer, shotblast or abrasive sandblast the contaminated areas to the satisfaction of the Engineer, at no additional cost.

- (B) Prior to silane application, protect cracks on the concrete bridge deck from materials that can interfere with the penetration and the curing of the silane material. Just prior to placement of the silane, remove, by magnets and oil-free compressed air and vacuuming, any loose particles, such that no excess particles remain. The concrete deck shall be completely dry. Power washing will not be allowed.
- (C) The silane manufacturer may suggest cleaning and preparation methods other than those detailed by this special provision. The Engineer must approve such alternative methods prior to implementation.

SILANE APPLICATION

(A) Test Area

- (1) Test a small area of the surface (minimum 5 ft. by 5 ft.) before general application to ensure desired performance results, aesthetics, and application rates and to verify application technique. Allow 5–7 days for the product to react fully before evaluating.
- (2) Application rates may vary depending on field conditions and the substrate to be treated.
- (3) Conduct at least one absorption test in the test area, using a Rilem Tube Test. Acceptable results are no loss of water in the Rilem tube over a period of 20 minutes. Adjust application to achieve required repellent performance.
- (4) The manufacturer's representative shall assist the Contractor in determining the application rates. Use test applications on actual surfaces to determine accurate application rates. Extremely porous surfaces may require two (2) coats of silane.
- (5) Do not begin production application of silane until Engineer has approved the test area, including approval of aesthetics, color, texture, and appearance.

(B) Application

Immediately before placing silane, all exposed surfaces shall be completely dry and blown clean with oil-free compressed air to remove any loose dust and debris. Apply silane as soon as practical after the exposed surfaces have been properly prepared and conditions are satisfactory:

- (1) Stir material thoroughly before and during application.
- (2) Apply silane with low-pressure spray or by flooding, followed by brooming or squeegeeing for even distribution, in accordance with manufacturer's instructions.
- (3) Maintain operating pressures in sprayers used for application of the silane sealer material sufficiently low so that atomization or misting of the material does not occur.
- (4) Begin the application of the silane at the lowest elevation and proceed upward, toward higher elevations, unless otherwise approved by the Engineer.
- (5) Apply even distribution of silane. Take care when applying the silane, so that running or ponding does not occur.
- (6) Apply silane in a single application to the concrete deck surface with enough material to saturate the surface. Remove excess material with a broom or squeegee and dispose of

excess material appropriately. If a second coat is required, it should be applied “wet on wet” before first coat dries.

- (7) Application of sealant by spray methods will not be permitted when wind speeds are 20 mph or more, or if in the opinion of the Engineer, unsatisfactory results will be obtained. Other application methods or rescheduling will be required.
- (8) Avoid application with hand pump sprayers. For small areas of silane application, the use of hand pump sprayers must be approved by the Engineer.
- (9) Contractor shall protect from overspray all pedestrians, vehicles, plants and vegetation, and other areas not receiving silane application.
- (10) Allow product to penetrate the bridge deck and dry, as required by the manufacturer, prior to opening to traffic.

LIMITATIONS OF OPERATIONS

- (1) Prior to application of any silane sealer, cure concrete or concrete repairs for a minimum of 28 days or as required by the silane manufacturer.
- (2) Do not use silane material after the shelf life date.
- (3) Do not return unused material in opened containers to storage for later use. Either apply such material to appropriate areas on concrete deck surfaces or remove and appropriately dispose of it at offsite locations provided by the Contractor.
- (4) If expansion joints are not being replaced or have been replaced prior to shotblasting, they shall be protected from damage from the shotblasting operation. Deck drains and areas of curb or railing above the proposed surface shall be protected from the shotblasting operation.
- (5) Pick up and store all blast media and contaminants in a vacuum unit. Do not create dust during the blasting operation that will obstruct the view of motorists in adjacent roadways. Store, handle, and dispose of blast media and contaminants in accordance with all applicable local, state, and federal requirements.
- (6) Cover deck joint seal and elastomeric material, plug deck drain scuppers, seal cracks on underside of deck, and use other necessary protective measures to prevent leakage of silane below the concrete deck, to protect waterways, bridge components, pedestrians, vehicles, roadway, vegetation, and any other items or areas below or near the bridge.
- (7) Application of sealant by spray methods will not be permitted during windy conditions, if in the opinion of the Engineer, unsatisfactory results will be obtained. Other application methods or rescheduling will be required.
- (8) Avoid application with hand pump sprayers. For small areas of silane application, the use of hand pump sprayers might be allowed, but must be approved by the Engineer.
- (9) Protect traffic from rebound, dust, overspray, and construction activities. Provide appropriate shielding, as required and/or directed by the Engineer.
- (10) The Contractor shall provide suitable coverings (e.g. heavy-duty drop cloths) as needed to protect all exposed areas not to receive silane treatment, such as asphalt pavement, curbs, sidewalks, parapets, etc.

- (11) Clean and/or repair all damage or defacement resulting from Contractor’s operations to the Engineer’s satisfaction at no additional cost to the Department.
- (12) The equipment used for silane application must be clean of foreign materials and approved by the Engineer before use.
- (13) The surface to receive the treatment shall be dry for at least 48 hours before treatment and shall be free from sand, surface dust and dirt, oil, grease, chemical films, and other contaminants prior to application of the silane.
- (14) The surface, air, and material temperatures shall be between 40°F and 90°F during application.
- (15) Do not apply silane materials during cold, hot, or wet weather conditions or when adverse weather conditions are forecast within 12 hours of the completion of the silane application. Correct any coating damaged by rain or moisture by an additional application or as required by the silane manufacturer.
- (16) Protect prepared surfaces from precipitation and heavy dew during and after the application of the silane.
- (17) Conduct the work in a continuous operation, with the silane application as soon as practical following surface preparation.
- (18) Apply silane during the lowest temperature period of the day, typically between 1:00 a.m. and 9:00 a.m., when the cracks are open to the greatest extent.
- (19) Clean up, dispose of any surplus material, and restore any disturbed areas unless otherwise directed.
- (20) 100% Silane is a combustible liquid; take appropriate precautions during handling, storage, and operations. **KEEP AWAY FROM OPEN FLAME.**
- (21) Work crews should wear appropriate personal protection equipment and follow manufacturer’s recommendations when applying silane. Refer to the SDS and all applicable local, state, and federal laws, and rules and regulations of authorities having jurisdiction over the project, for specific guidance for personal and environmental protection and safety requirements.

MEASUREMENT AND PAYMENT

Shotblasting Bridge Deck will be measured and paid for at the contract unit price per square yard and will be full compensation for the shotblasting and necessary sandblasting and handwork to prepare the entire concrete bridge deck, and removal and disposal of all waste material generated.

Silane Deck Treatment will be measured and paid for at the contract unit price per square yard and will be full compensation for bridge deck surface and crack preparation; for furnishing and applying the silane deck treatment; for protection of waterways, bridge, and other nearby surfaces, vehicles, and pedestrians; and for all labor, tools, and incidentals necessary to complete the work.

Payment will be made under:

Pay Item	Pay Unit
Shotblasting Bridge Deck	Square Yard

Silane Deck Treatment

Square Yard

SILANE BARRIER RAIL TREATMENT**(SPECIAL)****DESCRIPTION**

This work consists of preparation of bridge concrete barrier rail surfaces and the furnishing and application of alkylalkoxysilane (silane) penetrant sealers, with 100% solids, to seal bridge concrete barrier rail surfaces and cracks. Prepare the bridge concrete barrier rail surfaces and apply the silane bridge concrete barrier rail sealer in accordance with this special provision and as indicated on the plans, or as approved by the Engineer.

Work includes: bridge concrete barrier rail surface preparation, placement of silane penetrant sealer, appropriate removal and disposal of excess and waste material, and any incidentals necessary to complete the project, as specified or as indicated on the plans.

SUBMITTALS

Submit for approval the following requested items and any other relevant documents:

- (A) A safety data sheet (SDS) for each shipment of the silane materials.
- (B) Silane material information and manufacturer's written preparation and application instructions.
- (C) Certification from an independent testing laboratory that the materials meet the requirements of these provisions. Do not incorporate these materials into the project until the Engineer has accepted and approved the certification for the material.
- (D) The dates of manufacture of the silane materials, their lot numbers and date of shelf-life expiration for each lot number.
- (E) A table indicating the likely cure time, in minutes, to allow vehicular traffic on the bridge where the concrete barrier rail surface has been treated. Provide time for the allowable ambient temperature range, in increments of 10° F.
- (F) A work plan for each structure that includes estimated times for surface preparation and silane application.

MATERIAL DELIVERY AND STORAGE

Store at the site sufficient quantities of silane materials to perform the entire application.

Deliver materials in manufacturer's original, unopened, undamaged containers with identification labels intact. Ensure that each container is clearly marked by the manufacturer with the following information:

- (A) Manufacturer's name and address.
- (B) Product name.
- (C) Date of manufacture.
- (D) Expiration date.
- (E) Lot identification number.
- (F) Container serial number.

Provide the Engineer a certification from the manufacturer, confirming that the silane materials meet the requirements of this special provision. Do not incorporate these materials into the project until the Engineer has accepted and approved the certification for the material. Submit such certification for each lot of material delivered to the project. In each certification, identify the serial or lot numbers of the containers certified.

The Engineer may require samples from each lot or container of materials delivered to the project or from containers at the point of use. When samples are required, furnish samples in accordance with the Engineer’s instructions.

Store silane materials in unopened containers in a clean, dry area between 40° F and 90° F. Store containers in a manner that prevents leakage or spillage.

MANUFACTURER’S REPRESENTATIVE

Provide a manufacturer’s representative on site for the duration of the surface preparation and silane application work, to provide expert assistance on surface preparation, storage, mixing, application, clean-up, and disposal of materials.

MATERIALS

Provide silane from a single manufacturer, and provide silane that conforms to requirements indicated in Table 1, below.

**Table 1
SILANE PROPERTIES**

Property	Test Method	Requirement
Silane Content		100%
VOC content	EPA method 24	Less than 350 g/l
Surface Appearance after Application		Unchanged
Flash Point	ASTM D3278	140° F, minimum
Resistance to Chloride Ion Penetration	AASHTO T259 and T260	Less than: 0.52 pounds/yd ³ (criteria of 1.5) at 1/2 inch level; 0.00 pounds/yd ³ (criteria of 0.75) at 1 inch level
Water absorption test	ASTM C 642	0.50% maximum/48 hours; 1.5% maximum/50 days
Scaling resistance	ASTM C 672	(non-air-entrained concrete) 0 rating “No Scaling” (100 cycles)
NCHRP 244		
Water weight gain	Series II - cube test	85% reduction, minimum
Absorbed chloride		87% reduction, minimum

Absorbed chloride	Series IV - Southern climate	95% reduction, minimum
-------------------	------------------------------	------------------------

SURFACE PREPARATION

Prepare the bridge concrete barrier rail surfaces for application of the silane in order to remove all existing grease, slurry, oils, paint, dirt, striping, curing compound, rust, membrane, weak surface mortar, or any other contaminants that could interfere with the proper adhesion, penetration, and the curing of the silane material.

Prepare a final surface that adheres to the following requirements:

- (A) For areas to receive silane treatment, clean by sandblasting or shotblasting. Select the size of shot or sand, and travel speed of the equipment to provide a uniformly clean surface with a uniform profile. Do not expose cleaned surfaces to vehicular traffic unless approved by the Engineer. If the bridge concrete barrier rail surfaces become contaminated before placing the silane treatment, shotblast or abrasive sandblast the contaminated areas to the satisfaction of the Engineer, at no additional cost.
- (B) Power washing of the bridge concrete barrier rail may be allowed as approved by the Engineer, but the concrete barrier shall be allowed to dry a minimum of 48 hours prior to application of the silane treatment.
- (C) Prior to silane application, protect cracks on the bridge concrete barrier rail from materials that can interfere with the penetration and the curing of the silane material. Just prior to placement of the silane, remove, by magnets and oil-free compressed air and vacuuming, any loose particles, such that no excess particles remain.
- (D) Prior to silane application, the bridge concrete barrier rail shall be completely dry.
- (E) The silane manufacturer may suggest cleaning and preparation methods other than those detailed by this special provision. The Engineer must approve such alternative methods prior to implementation.

SILANE APPLICATION

(A) Test Area

- (1) Test a small area of the surface (minimum 2 ft. by 2 ft.) before general application to ensure desired performance results, aesthetics, and application rates and to verify application technique. Allow 5–7 days for the product to react fully before evaluating.
- (2) Application rates may vary depending on field conditions and the substrate to be treated.
- (3) Conduct at least one absorption test in the test area, using a Rilem Tube Test. Acceptable results are no loss of water in the Rilem tube over a period of 20 minutes. Adjust application to achieve required repellent performance.
- (4) The manufacturer's representative shall assist the Contractor in determining the application rates. Use test applications on actual surfaces to determine accurate application rates. Extremely porous surfaces may require two (2) coats of silane.
- (5) Do not begin production application of silane until Engineer has approved the test area, including approval of aesthetics, color, texture, and appearance.

(B) Application

Immediately before placing silane, all exposed surfaces shall be completely dry and blown clean with oil-free compressed air to remove any loose dust and debris. Apply silane as soon as practical after the exposed surfaces have been properly prepared and conditions are satisfactory:

- (1) Stir material thoroughly before and during application.
- (2) Apply silane using low-pressure pumping equipment with a wet fan type spray nozzle. Rollers with a 1" nap or brushes are permitted. On vertical surfaces, apply the silane in a flooding application from the bottom upward, in accordance with manufacturer's instructions.
- (3) Maintain operating pressures in sprayers used for application of the silane sealer material sufficiently low, so that atomization or misting of the material does not occur.
- (4) Apply even distribution of silane. Take care when applying the silane, so that running or ponding does not occur.
- (5) Apply silane in a single application to the barrier rail surface with enough material to saturate the surface. Remove excess material with a roller or brush and dispose of excess material appropriately. If a second coat is required, it should be applied "wet on wet" before first coat dries.
- (6) Application of sealant by spray methods will not be permitted when wind speeds are 20 mph or more, or if in the opinion of the Engineer, unsatisfactory results will be obtained. Other application methods or rescheduling will be required.
- (7) Avoid application with hand pump sprayers. For small areas of silane application, the use of hand pump sprayers must be approved by the Engineer.
- (8) Contractor shall protect from overspray all pedestrians, vehicles, plants and vegetation, and other areas not receiving silane application. Damages that occur due to overspray shall be the responsibility of the Contractor.
- (9) Allow product to penetrate the bridge concrete barrier rail and dry, as required by the manufacturer, prior to opening to traffic.

LIMITATIONS OF OPERATIONS

- (1) Prior to application of any silane sealer, cure concrete or concrete repairs for a minimum of 28 days or as required by the silane manufacturer.
- (2) Do not use silane material after the shelf life date.
- (3) Do not return unused material in opened containers to storage for later use. Either apply such material to appropriate areas on barrier rail surfaces or remove and appropriately dispose of it at offsite locations provided by the Contractor.
- (4) Pick up and store all blast media and contaminants in a vacuum unit. Do not create dust during the blasting operation that will obstruct the view of motorists in roadways adjacent,

above, below, or surrounding the silane treatment area. Store, handle, and dispose of blast media and contaminants in accordance with all applicable local, state, and federal requirements.

- (5) Cover deck joint seal and elastomeric material, plug deck drain scuppers, seal cracks on underside of deck, and use other necessary protective measures to prevent leakage of silane below the concrete deck and beyond the concrete barrier rail, to protect waterways, bridge components, pedestrians, vehicles, roadway, vegetation, and any other items or areas below or near the bridge.
- (6) Application of sealant by spray methods will not be permitted during windy conditions, if in the opinion of the Engineer, unsatisfactory results will be obtained. Other application methods or rescheduling will be required.
- (7) Avoid application with hand pump sprayers. For small areas of silane application, the use of hand pump sprayers might be allowed, but must be approved by the Engineer.
- (8) Protect traffic from rebound, dust, overspray, and construction activities. Provide appropriate shielding, as required and/or directed by the Engineer. Damages that occur due to the Contractor's operations shall be the responsibility of the Contractor.
- (9) The Contractor shall provide suitable coverings (e.g. heavy-duty drop cloths) as needed to protect all exposed areas not to receive surface preparation and silane treatment.
- (10) Clean and/or repair all damage or defacement resulting from Contractor's operations to the Engineer's satisfaction at no additional cost to the Department.
- (11) The equipment used for silane application must be clean of foreign materials and approved by the Engineer before use.
- (12) The surface to receive the treatment shall be dry for at least 48 hours before treatment and shall be free from sand, surface dust and dirt, oil, grease, chemical films, and other contaminants prior to application of the silane.
- (13) The surface, air, and material temperatures shall be between 40°F and 90°F during application.
- (14) Do not apply silane materials during cold, hot, or wet weather conditions or when adverse weather conditions are forecasted within 12 hours of the completion of the silane application. Correct any coating damaged by rain or moisture by an additional application or as required by the silane manufacturer.
- (15) Protect prepared surfaces from precipitation and heavy dew during and after the application of the silane.
- (16) Conduct the work in a continuous operation, with the silane application as soon as practical following surface preparation.
- (17) Apply silane during the lowest temperature period of the day, typically between 1:00 a.m. and 9:00 a.m., when the cracks are open to the greatest extent.
- (18) Clean up, dispose of any surplus material, and restore any disturbed areas unless otherwise directed.

- (19) 100% Silane is a combustible liquid; take appropriate precautions during handling, storage, and operations. **KEEP AWAY FROM OPEN FLAME.**
- (20) Work crews should wear appropriate personal protection equipment and follow manufacturer’s recommendations when applying silane. Refer to the SDS and all applicable local, state, and federal laws, and rules and regulations of authorities having jurisdiction over the project, for specific guidance for personal and environmental protection and safety requirements.

MEASUREMENT AND PAYMENT

Surface Preparation for Concrete Barrier Rail will be measured and paid for at the contract unit price per square foot and will be full compensation for the shotblasting, sandblasting, or other necessary surface preparation and handwork to prepare the entire bridge concrete barrier rail and removal and disposal of all blast media and waste material generated.

Silane Barrier Rail Treatment will be measured and paid for at the contract unit price per square foot and will be full compensation for bridge concrete barrier rail and crack preparation; for furnishing and applying the silane barrier rail treatment; removal and disposal of excess and waste material generated; for protection of waterways, bridge, and other nearby surfaces, vehicles, and pedestrians; and for all labor, tools, and incidentals necessary to complete the work.

Payment will be made under:

Pay Item	Pay Unit
Surface Preparation for Concrete Barrier Rail	Square Foot
Silane Barrier Rail Treatment	Square Foot

BRIDGE JOINT DEMOLITION

(SPECIAL)

DESCRIPTION

This special provision addresses the removal of existing joint material and adjacent concrete headers to facilitate the installation of new elastomeric concrete headers and bridge joint seals at the locations noted in the contract plans.

EQUIPMENT

Use the following surface preparation equipment:

- (A) Sawing equipment capable of sawing concrete to a specified depth.
- (B) Power driven hand tools for removal of concrete are required that meet the following requirements:
- (C) Pneumatic hammers weighing a nominal 15 lbs. (7 kg) or less
- (D) Pneumatic hammer chisel-type bits that do not exceed the diameter of the shaft in width.
- (E) Hand tools such as hammers and chisels for removal of final particles of concrete.

REMOVAL AND PREPARATION

Prior to any construction, take the necessary precautions to ensure debris from joint construction is not allowed to fall below the bridge deck.

Remove existing joint material by methods approved by the Engineer. Provide a 1” deep saw cut around the perimeter of areas noted for bridge deck removal.

Remove by chipping with hand tools elastomeric concrete headers adjacent to the joint to the limits shown on the contract plans. Use a small chipping hammer (15 lb. class) to prepare the edges of the repair area to limit micro fractures. In addition, all loose and unsound concrete shall be removed.

In overhangs, removing concrete areas greater than 0.60 ft²/ft length of bridge will require overhang support. Submit the overhang support method to the Engineer for approval.

Care shall be taken not to cut, stretch, or damage any exposed reinforcing steel. Dispose of the removed concrete.

If the condition of the concrete is such that deep spalls or sheer faces result, notify the Engineer for the proper course of action.

Clean, repair or replace rusted or loose reinforcing steel. Thoroughly clean the newly exposed surface to be free of all grease, oil, curing compounds, acids, dirt, or loose debris.

MEASUREMENT AND PAYMENT

Bridge Joint Demolition will be measured and paid for at the contract unit price bid per square foot and will be full compensation for removal, containment, and disposal of existing joint material and concrete and shall include the cost of labor, tools, equipment, and incidentals necessary to complete the work.

Pay Item	Pay Unit
Bridge Joint Demolition	Square Feet

ELASTOMERIC CONCRETE FOR PRESERVATION

(2-11-19)

DESCRIPTION

Elastomeric concrete is a mixture of a two-part polymer consisting of polyurethane and/or epoxy and kiln-dried aggregate. Provide an elastomeric concrete and binder system that is preapproved. Use the concrete in the blocked-out areas on both sides of the bridge deck joints as indicated on the plans.

MATERIALS

Provide materials that comply with the following minimum requirements at 14 days (or at the end of the specified curing time).

ELASTOMERIC CONCRETE PROPERTIES	TEST METHOD	MINIMUM REQUIREMENT
Compressive Strength, psi	ASTM D695	2000
5% Deflection Resilience	ASTM D695	95
Splitting Tensile Strength, psi	ASTM D3967	625
Bond Strength to Concrete, psi	ASTM C882 (C882M)	450
Durometer Hardness	ASTM D2240	50

BINDER PROPERTIES (without aggregate)	TEST METHOD	MINIMUM REQUIREMENT
Tensile Strength, psi	ASTM D638	1000
Ultimate Elongation	ASTM D638	150%
Tear Resistance, lb/in	ASTM D624	200

In addition to the requirements above, the elastomeric concrete must be resistant to water, chemical, UV and ozone exposure and withstand temperature extremes. Elastomeric concrete systems requiring preheated aggregates are not allowed.

PREQUALIFICATION

Manufacturers of elastomeric concrete materials shall submit samples (including aggregate, primer and binder materials) and a Type 3 certification in accordance with Article 106-3 of the *Standard Specifications* for prequalification to:

North Carolina Department of Transportation
Materials and Tests Unit
1801 Blue Ridge Road
Raleigh, NC 27607

Prequalification will be determined for the system. Individual components will not be evaluated, nor will individual components of previously evaluated systems be deemed prequalified for use.

The submitted binder (a minimum volume of 1 gallon) and corresponding aggregate samples will be evaluated for compliance with the Materials requirements specified above. Systems satisfying

all of the Materials requirements will be prequalified for a one (1) year period. Before the end of this period new product samples shall be resubmitted for prequalification evaluation.

If, at any time, any formulation or component modifications are made to a prequalified system that system will no longer be approved for use.

INSTALLATION

The elastomeric concrete shall not be placed until the reinforced concrete deck slab or overlay has cured for seven (7) full days and reached a minimum strength of 3,000 psi.

Provide a manufacturer's representative at the bridge site during the installation of the elastomeric concrete to ensure that all steps being performed comply with all manufacturer installation requirements including, but not limited to: weather conditions (ambient temperature, relative humidity, precipitation, wind, etc.), concrete deck surface preparation, binder and aggregate mixing, primer application, elastomeric concrete placement, curing conditions and minimum curing time before joint exposure to traffic. Do not place elastomeric concrete if the ambient air or surface temperature is below 45°F.

Prepare the concrete surface within 48 hours prior to placing the elastomeric concrete. Before placing the elastomeric concrete, all concrete surfaces shall be thoroughly cleaned and dry. Sandblast the concrete surface in the block-out and clear the surface of all loose debris. Do not place the elastomeric concrete until the surface preparation is completed and approved.

Prepare and apply a primer, as per manufacturer's recommendations, to all concrete faces to be in contact with elastomeric concrete, and to areas specified by the manufacturer.

Prepare, batch, and place the elastomeric concrete in accordance with the manufacturer's instructions. Place the elastomeric concrete in the areas specified on the plans while the primer is still tacky and within two (2) hours after applying the primer. Trowel the elastomeric concrete to a smooth finish.

The joint opening in the elastomeric concrete shall match the formed opening in the concrete deck prior to sawing the joint.

FIELD SAMPLING

Provide additional production material to allow freshly mixed elastomeric concrete to be sampled for acceptance. A minimum of six (6) 2-inch cube molds and three (3) 3-inch diameter x 6-inch cylinders will be taken by the Department for each day's production. Compression, splitting tensile, and durometer hardness testing will be performed by the Department to determine acceptance. Materials failing to meet the requirements listed above are subject to removal and replacement at no cost to the Department.

BASIS OF PAYMENT

Elastomeric Concrete for Preservation will be measured and paid for at the contract unit price bid per cubic foot and will be full compensation for material, labor, tools, and equipment necessary for satisfactorily installing the elastomeric concrete in place.

Pay Item	Pay Unit
Elastomeric Concrete for Preservation	Cubic Feet

FOAM JOINT SEALS FOR PRESERVATION

(SPECIAL)

SEALS

Use preformed seals compatible with concrete and resistant to abrasion, oxidation, oils, gasoline, salt, and other materials that are spilled on or applied to the surface. Use a resilient, UV stable, preformed, impermeable, flexible, expansion joint seal. The joint seal shall consist of low-density, closed cell, cross-linked polyethylene non-extrudable foam. The joint seal shall contain no EVA (Ethylene Vinyl Acetate). Cell generation shall be achieved by being physically blown using nitrogen. No chemical blowing agents shall be used in the cell generation process.

Use seals manufactured with grooves 1/8" ± wide by 1/8" ± deep and spaced between 1/4" and 1/2" apart along the bond surface running the length of the joint. Use seals with a depth that meets the manufacturer's recommendation, but is not less than 70% of the uncompressed width. Provide a seal designed so that, when compressed, the center portion of the top does not extend upward above the original height of the seal by more than 1/4". Provide a seal that has a working range of 30% tension and 60% compression and meets the requirements given below.

TEST	TEST METHOD	REQUIREMENT
Tensile Strength	ASTM D3575, Suffix T	110 – 130 psi
Compression Set	ASTM D1056 Suffix B, 2 hr recovery	10% - 16%
Water Absorption	ASTM D3575	< 0.03 lb/ft ²
Elongation at Break	ASTM D3575	180% - 210%
Tear Resistance	ASTM D624 (D3575, Suffix G)	14 – 20 pli
Density	ASTM D3575, Suffix W, Method A	1.8 – 2.2 lb/ft ³
Toxicity	ISO-10993.5	Pass (not cytotoxic)

Have the top of the joint seal clearly shop marked. Inspect the joint seals upon receipt to ensure that the marks are clearly visible before installation.

BONDING ADHESIVE

Use a two-component, 100% solid, modified epoxy adhesive supplied by the joint seal manufacturer that meets the requirements given below.

TEST	TEST METHOD	REQUIREMENT
Tensile strength	ASTM D638	3,000 psi (min.)
Compressive strength	ASTM D695	7,000 psi (min.)
Hardness	Shore D Scale	75-85 psi
Water Absorption	ASTM D570	0.25% by weight max.
Elongation to Break	ASTM D638	5% (max.)
Bond Strength	ASTM C882	2,000 psi (min.)

Use an adhesive that is workable to 40°F. When installing in ambient air or surface temperatures below 40°F or for application on moist, difficult to dry concrete surfaces, use an adhesive specified by the manufacturer of the joint seal.

SAWING THE JOINT

The concrete at the face of the joint (elastomeric concrete, polyester polymer concrete, Portland cement concrete, etc.) shall have sufficient time to cure such that no damage can occur to the concrete prior to sawing to the final width and depth as specified in the plans.

When sawing the joint to receive the foam seal, always use a rigid guide to control the saw in the desired direction. To control the saw and to produce a straight line as indicated on the plans, anchor and positively connect a template or a track to the bridge deck. Do not saw the joint by visual means such as a chalk line. Fill the holes used for holding the template or track to the deck with an approved flowable, non-shrink, non-metallic grout.

Saw cut to the desired width and depth in one (1) or two (2) passes of the saw by placing and spacing two (2) metal blades on the saw shaft to the desired width for the joint opening.

The desired depth is the depth of the seal plus ¼" above the top of the seal plus approximately 1" below the bottom of the seal. An irregular bottom of sawed joint is permitted as indicated on the plans. Grind exposed corners on saw cut edges to a ¼" chamfer.

Saw cut a straight joint, centered over the formed opening and to the desired width specified in the plans. Prevent any chipping or damage to the sawed edges of the joint.

Remove any staining or deposited material resulting from sawing with a wet blade to the satisfaction of the Engineer.

PREPARATION OF SAWED JOINT FOR SEAL INSTALLATION

The elastomeric concrete or polyester polymer concrete at the joint shall cure a minimum of 24 hours prior to seal installation. Portland cement concrete at the joint shall cure following the special provisions.

After sawing the joint, the Engineer will thoroughly inspect the sawed joint opening for spalls, popouts, cracks, etc. All necessary repairs will be made by the Contractor prior to blast cleaning and installing the seal, at no cost to the Department.

Clean the joints by sandblasting with clean dry sand immediately before placing the bonding agent. Sandblast the joint opening to provide a firm, clean joint surface free of curing compound, loose material and any foreign matter. Sandblast the joint opening without causing pitting or uneven surfaces. The aggregate in the joint concrete may be exposed after sandblasting.

After blasting, either brush the surface with clean brushes made of hair, bristle, or fiber, blow the surface with compressed air, or vacuum the surface until all traces of blast products and abrasives are removed from the surface, pockets, and corners.

If nozzle blasting is used to clean the joint opening, use compressed air that does not contain detrimental amounts of water or oil.

Examine the blast-cleaned surface and remove any traces of oil, grease, or smudge deposited in the cleaning operations.

Bond the seal to the blast-cleaned surface on the same day the surface is blast cleaned.

SEAL INSTALLATION

Install the joint seal according to the manufacturer's procedures and recommendations and as recommended below. Do not install the joint seal if the ambient air or surface temperature is below 45°F. Have a manufacturer's certified trained factory representative present during the installation of the first seal of the project.

Before installing the joint seal, check the uninstalled seal length to ensure the seal is the same length as the deck opening. When the joint seal requires splicing, use the heat welding method by placing the joint material ends against a Teflon heating iron of 425-475°F for 7 - 10 seconds, then pressing the ends together tightly. Do not test the welding until the material has completely cooled.

Begin installation by protecting the top edges of the concrete deck adjacent to the vertical walls of the joint as a means to minimize clean up. Stir each epoxy bonding agent component independently, using separate stirring rods for each component to prevent premature curing of the bonding agent. Pour the two (2) components, at the specified mixing ratio, into a clean mixing bucket. Mix the components with a low speed drill (400 rpm max.) until a uniform gray color is achieved without visible marbling. Apply bonding agent to both sides of the joint concrete, as well as both sides of the joint seal, making certain to fill completely the grooves with epoxy. With gloved hands, compress the joint seal and with the help of a blunt probe, push the seal into the joint opening until the seal is recessed approximately 1/4" below the surface. When pushing down

on the joint seal, apply pressure only in a downward direction. Do not push the joint seal into the joint opening at an angle that would stretch the material. Seals that are stretched during installation shall be removed and rejected. Once work on placing a seal begins, do not stop until it is completed. Clean the excess epoxy from the top of the joint seal immediately with a trowel. Do not use solvents or any cleaners to remove the excess epoxy from the top of the seal. Remove the protective cover at the joint edges and check for any excess epoxy on the surface. Remove excess epoxy with a trowel, the use of solvents or any cleaners will not be allowed.

The installed system shall be watertight and will be monitored until final inspection and approval.

(A) Watertight Integrity Test

- (1) Upon completion of each foam seal expansion joint, perform a water test on the top surface to detect any leakage. Cover the roadway section of the joint from curb to curb, or barrier rail to barrier rail, with water, either ponded or flowing, not less than 1 inch above the roadway surface at all points. Block sidewalk sections and secure an unnozzled water hose delivering approximately 1 gallon of water per minute to the inside face of the bridge railing, trained in a downward position about six (6) inches above the sidewalk, such that there is continuous flow of water across the sidewalk and down the curb face of the joint.
- (2) Maintain the ponding or flowing of water on the roadway and continuous flow across sidewalks and curbs for a period of five (5) hours. At the conclusion of the test, the underside of the joint is closely examined for leakage. The foam seal expansion joint is considered watertight if no obvious wetness is visible on the Engineer’s finger after touching a number of underdeck areas. Damp concrete that does not impart wetness to the finger is not considered a sign of leakage.
- (3) If the joint system leaks, locate the place(s) of leakage and take any repair measures necessary to stop the leakage at no additional cost to the Department. Use repair measures recommended by the manufacturer and approved by the Engineer prior to beginning corrective work.
- (4) If measures to eliminate leakage are taken, perform a subsequent water integrity test subject to the same conditions as the original test. Subsequent tests carry the same responsibility as the original test and are performed at no additional cost to the Department.

Do not place pavement markings on top of foam joint seals.

BASIS OF PAYMENT

Foam Joint Seals for Preservation will be measured and paid for at the contract unit price bid per linear foot and will be full compensation for furnishing all material, labor, tools, and equipment necessary for installing these seals in place and accepted.

Pay Item

Foam Joint Seals for Preservation

Pay Unit

Linear Feet

REPAIRS TO PRESTRESSED CONCRETE CORED SLABS**(SPECIAL)****DESCRIPTION**

Work includes removal of concrete in spalled and/ or delaminated areas of the existing prestressed concrete cored slab beams, in reasonably close conformity with the lines, depth, and details shown on the plans, described herein, and as established by the Engineer. This work also includes straightening, cleaning, and replacement of reinforcing steel; application of High Ratio Co-Polymerized Calcium Sulfonate (HRCSA) corrosion penetrant; removing all loose materials; removing and disposing of debris; formwork if required; applying repair material; and protecting adjacent areas of the bridge and environment from work operations. The repair material shall be one of the materials described below, unless otherwise noted in the plans or special provisions.

The location and extent of repairs shown on the plans are general in nature. The Engineer shall determine the extent of removal in the field based on an evaluation of the condition of the exposed surfaces.

The Contractor shall coordinate removal operations with the Engineer. No more than 30% of the bearing area under a beam shall be removed without a temporary support system and approval from the Engineer.

Any portion of the structure that is damaged from construction operations shall be repaired to the Engineer's satisfaction, at no extra cost to the Department.

SUBMITTALS

Submit all of the following to the Engineer for review and approval before scheduling the pre-construction meeting. Allow 40 calendar days for review and approval, or acceptance, of working drawings, from the date they are received, until they are returned by the Engineer.

- A. HRCSA (High Ratio Co-Polymerized Calcium Sulfonate) Penetrant
- B. Polymer Modified Concrete Repair Material
- C. Epoxy Mortar Repair Material

GENERAL SURFACE PREPARATION

Prior to starting the repair operation, confirm and delineate all surfaces and areas assumed to be deteriorated by visually examining and sounding the concrete surface with a hammer (14 ounce or larger) or other approved method. The Engineer is the sole judge in determining the limits of deterioration.

Remove surface concrete to verify that a ½" sawcut depth will not damage existing reinforcing steel or prestressing strand. If confirmed, introduce a shallow saw cut a minimum ½" in depth around the repair area, at right angles to the concrete surface. Within the limits of the sawcut, remove all concrete to a minimum depth of ½". Remove all unsound concrete in the repair area,

and where the bond between existing concrete and reinforcing steel has been compromised, or where more than half of the diameter of the reinforcing steel is exposed, remove concrete 1 inch behind the reinforcing steel. For concrete removal, use a 17-pound (maximum) pneumatic hammer with points that do not exceed the width of the shank or use hand picks or chisels as directed by the Engineer. Do not cut or remove the existing reinforcing steel. Unless specifically directed by the Engineer, do not remove concrete deeper than 1 inch below the reinforcing steel. Prevent cutting, stretching, or damaging of reinforcing steel.

As necessary, remove grease, wax, salt, oil, and other contaminants by scrubbing with an industrial grade detergent or degreasing compound followed by a mechanical cleaning. Remove dirt, dust, laitance, and curing compounds by gritblasting, sanding, or etching with 15% hydrochloric acid. Acid etch only if approved by the Engineer. Follow acid etching by scrubbing and flushing with copious amounts of clean water. Check the cleaning using moist pH paper. Water cleaning is complete when the paper reads ten (10) or higher.

Abrasive blast all exposed concrete surfaces and existing reinforcing steel and strand in the repair area to clean the area and remove all loose materials. Use a wire brush or other hand tools to clean all exposed reinforcing steel and strand not sufficiently cleaned by blasting operations.

After blast cleaning, examine the reinforcing steel and prestressing strand. If there is more than 50% reduction in the diameter of reinforcing steel, splice in and securely tie supplemental reinforcing bars within the original concrete cover. Lap the bars sufficiently to develop the full strength of the bar and, if necessary, provide additional removal of concrete to achieve the required splice length. Reinforcing steel that is required for the repairs shall be in accordance with Section 425 of the *Standard Specifications*.

Following all cleaning, remove all dust and loose material with air blast or vacuum cleaning.

Apply HRCSA Penetrant to the prepared reinforcing steel and prestressing strand. Do not apply excessive amount of HRCSA Penetrant; HRCSA shall not extend onto surrounding concrete by more than ¼". HRCSA Penetrant shall be Zero Volatile Organic Compound (VOC), 100% Solids Penetrant/Sealer (Minimum 15% active sulfonate, a total base number of 135 to 165, must maintain a 9-11 to 1 ratio Active Sulfonate to Total Base Number as determined by Total Base Number Determination testing, Procedure No. 817/4.9/T1401). Allow HRCSA penetrant to dry before placing concrete repair material. Drying time is temperature, humidity, and film thickness dependent. Use manufacturer's recommended drying schedule to estimate the drying time of the penetrating sealer for application of the concrete repair material. If the manufacturer's recommendations allow, the use of forced air pressure to dry the surface will be permitted.

REPAIR MATERIAL OPTIONS

(A) Polymer Modified Concrete Repair Material

Repair material shall be polymer modified cement mortar/grout for vertical or overhead applications and shall be suitable for applications in marine environments. Material shall

be approved for use by NCDOT. Submit repair material to the Engineer for review and approval prior to beginning the work. Color of repair material shall be concrete gray. Prior to the application of polymer modified cement mortar/grout, prepare concrete substrate as indicated in "General Surface Preparation," above. Final preparation of the substrate concrete surface prior to repair material application shall be in accordance with the repair material manufacturer's recommendations.

When surface preparation is completed, mix and apply repair mortar in accordance with manufacturer's recommendations. Use aggregate that is washed, kiln-dried, and bagged. Aggregate size for repair material shall not exceed 2/3 of the minimum depth of the repair area, or 3/4 of the depth of excavation behind the reinforcing steel, whichever is smaller. As recommended by the repair material manufacturer, apply bonding agent to all repair areas immediately prior to placing repair mortar.

After placing the repair mortar, remove excessive material and provide a smooth, flush surface. Provide and use abrading tools as required to achieve a smooth and flush finish. Abrading tools shall not be used until the repair mortar has reached design strength.

(B) Epoxy Mortar Repair Material

Repair material shall be epoxy based mortar/grout for vertical or overhead applications and shall be suitable for applications in marine environments. Material shall be approved for use by NCDOT. Submit repair material to the Engineer for review and approval prior to beginning the work. Color of repair material shall be concrete gray.

Prior to the application of epoxy mortar/grout, prepare concrete substrate as indicated in "General Surface Preparation," above. Final preparation of the substrate concrete surface prior to repair material application shall be in accordance with the repair material manufacturer's recommendations.

When surface preparation is completed, mix and apply repair epoxy mortar in accordance with manufacturer's recommendations. Use aggregate that is washed, kiln-dried, and bagged. Aggregate size for repair material shall not exceed 2/3 of the minimum depth of the repair area, or 3/4 of the depth of excavation behind the reinforcing steel, whichever is smaller.

After placing the repair mortar, remove excessive material and provide a smooth, flush surface. Provide and use abrading tools as required to achieve a smooth and flush finish. Abrading tools shall not be used until the repair mortar has reached design strength.

MEASUREMENT AND PAYMENT

Repairs to Prestressed Concrete Cored Slabs will be measured and paid for at the contract unit price bid per cubic foot and will be full compensation for removal, containment, and disposal off-site of unsound concrete, including the cost of materials, reinforcing steel, labor, tools, equipment, and incidentals necessary to complete the repair work. Depth will be measured from

the original outside concrete face. The Contractor and Engineer will measure quantities after removal of unsound concrete and before application of repair material. Payment will also include the cost of sandblasting, surface cleaning and preparation, cleaning of reinforcing steel, placement of new reinforcing steel, furnishing and application of HRCSA penetrant, testing of the soundness of the exposed concrete surface, furnishing and installation of repair mortar/grout material, curing and sampling of mortar/grout, and protection/cleaning of adjacent areas from splatter or leakage.

Payment will be made under:

Pay Item	Pay Unit
Repairs to Prestressed Concrete Cored Slabs	Cubic Feet
Splicing of Prestressing Strand	Each

POST-TENSIONING STRAND REPLACEMENT

(SPECIAL)

Description

This specification establishes the minimum requirements for replacing existing transverse post tensioning strands in adjacent precast beam units.

Materials

Prestressing strand and appurtenances as shown in the plans and in accordance with this provision and the Standard Specifications.

Construction Methods

Remove existing strand grout pockets using care to not damage prestressed beams. Any damage to existing prestressed beams shall be repaired to the satisfaction of the Engineer at no additional cost.

Remove existing prestressing strand, sheath, and strand vises. Existing steel backing plates may be reused as approved by the Engineer. If existing backing plates are not suitable, as determined by the Engineer furnish and install new steel backing plates as detailed in the plans.

Install new prestressing strand in accordance with the plans and applicable sections of Article 430-6 of the Standard Specifications. When indicated in the plans, perform phased tensioning of the strands with an initial preload and final tensioning load as shown in the plans.

Preloading of beams to align strand ducts will be allowed. Contractor shall ensure that the camber in the beams do not deflect below zero camber and are not overstressed at any time during preloading, strand installation, and tensioning.

Remove all beam preloads prior to tensioning the strands.

Submittals

Submit shop drawings, product cut sheets, and preloading calculations to the Engineer for approval prior to start of work. Submittal shall include post tensioning plan and sequence of tensioning. Include calculations and details as required to ensure prestressed concrete beams are not overstressed throughout all stages of the work.

Measurement and Payment

Post-Tensioning Strand Replacement will be measured and paid for at the contract unit price bid per each strand and will be full compensation for removal, containment, and disposal off-site of materials removed, furnishing and installing new post tensioning system and all associated work including the cost of submittals, materials, labor, tools, strand jacks, equipment and incidentals necessary to accomplish the work.

Pay Item	Pay Unit
Post-Tensioning Strand Replacement	Each

ASPHALT PLUG JOINT FOR PRESERVATION

(SPECIAL)

GENERAL

This work shall consist of supplying and installing a binder and aggregate system composed of specially blended polymer modified asphalt and specific aggregate placed in layers into a prepared expansion joint block-out. When properly installed, the joint system will provide a flexible waterproof bridge joint, which will allow for a joint movement of 1 inch in expansion and 1 inch in compression.

Joint material shall be hot applied, pre-mixed bituminous material that will provide a smooth riding surface and a waterproof joint. The Contractor shall prepare the surface to be repaired by saw cutting to a minimum of 20 inches wide and two (2) inches in depth, per the manufacturer’s specifications, or as directed by the Engineer, removing all loose material, and cleaning the area with compressed air. No repairs shall be made during periods of rain, snow, or sleet. Standing water shall be removed prior to placement of material.

SUBMITTALS

Prior to construction, the Contractor shall submit the following to the Engineer for review and approval:

- (A) Complete and detailed Shop Drawings of selected asphalt plug joint system. Shop Drawings shall include information covering the materials and their properties, installation procedures, storage and handling requirements, and Material Safety Data Sheets.

- (B) Shop Drawings for a temporary joint system if daily work is to be terminated prior to completion of installing the final approved system.
- (C) The resumes of the Contractor's staff that will be on site installing the asphalt plug joint system with manufacturer installation certifications and their experience installing the system, along with the names and telephone numbers of contact persons for recent projects where they have installed the system.
- (D) Material certifications and sampling shall be as required as per the NCDOT *Standard Specifications* Section 106.

MATERIALS

All materials shall meet the specifications as approved by the Engineer prior to use. All components of the asphalt plug joint system shall be from one manufacturer. The manufacturer of the asphaltic plug joint shall provide evidence that a minimum of 5,000 linear feet of asphaltic plug joint, furnished by the same manufacturer and used in conditions similar to this application, have been installed and have had at least two (2) years of satisfactory service.

(A) Binder Material

The bridge joint binder shall be a polymer modified asphalt and shall meet the following requirements when tested according to ASTM test methods:

PROPERTY	ASTM TEST METHOD	REQUIREMENT
Asphalt Compatibility	D 5329	Pass
Bond (Non-immersed)	D 5329	Pass 3 cycles @ -20°F, 50% Pass 3 cycles @ 0°F, 100%
Penetration (Non-immersed)	D 5329	1 mm minimum @ 0 ± 2°F, 200 g, 60 sec 9 mm maximum @ 77° ± 2°F, 150 g, 5 sec
Ductility	D 113	40 cm minimum @ 77° ± 2°F
Flexibility	D 5329 (Note: Do not oven age specimen. After 24 hours at standard conditions, allow specimens to condition at -10° ± 2 F for 2 hours before testing)	Pass @ 10° ± 2°F
Flow	D 5329	3 mm maximum @ 140 ± 2°F, 5 hours
Resilience	D 5329	40% minimum @ 77° ± 2°F
Softening Point	D 36	180°F, minimum
Tensile Adhesion	D 5329	550% minimum
Safe Heating Temperature		390°F to 410°F
Recommended Pouring Temperature		360°F to 390°F

(B) Aggregate

The specified aggregate shall be crushed, double washed, supplied in a ¾” gradation, and shall meet the following requirements:

GRADATION	
Sieve Size	Percent Passing

7/8"	95-100
5/8"	30-50
1/2"	10-30
3/8"	0-7
1/4"	-
#8	-

(C) Backer Rod

The backer rod shall be a closed cell, foam expansion joint filler, capable of withstanding the elevated temperature of the polymeric binder. The backer rod shall have the following typical physical properties using a two (2) inch specimen and test method ASTM D-545:

Density	2.0 lbs/cf min.
Tensile Strength	30 psi min.
Compression	5 psi @ 25% min.
Water Absorption	0.03 g/cc by weight min.
Temperature @ 410°F	No Melting

(D) Bridging Plate

The bridging plate shall be a steel plate conforming to the requirements of ASTM Designation: A 36/A 36M, ¼ inch thick by 8 inch minimum wide, cut in 4ft to 5ft lengths. The top corners of the steel bridging plates shall be rounded prior to installation. Holes for locating pins shall be drilled on a longitudinal centerline at 12 inch intervals. The locating pins shall be 16d common steel nails minimum or equivalent.

INSTALLATION CREWS

The joint system is to be installed only by factory trained and certified installation professionals with documented training.

INSTALLATION

The asphalt plug joint system shall be installed in accordance with the manufacturer’s latest instructions and specifications. Manufacturer’s representatives shall be present during the entire installation to ensure satisfactory results are obtained.

The installation shall be centered over the expansion joint gap as indicated on the plans with a minimum depth of two (2) inches. It shall not be installed when ambient or substrate temperatures are below 40°F, when rain is imminent or as directed by the Engineer.

(A) Sawing the Joint

Sawcut and remove bituminous overlay and waterproofing membrane to the required dimensions as shown on the plans. If required, a leveling course shall be applied to concrete surfaces prior to placing bridging plates. Vertical surfaces of bituminous overlay shall be cleaned to remove all water and cutting dust.

When sawing for the installation of the plug joint, always use a rigid guide to control the saw in the desired direction. To control the saw and to produce a straight line as indicated on the plans, anchor and positively connect a template or a track to the bridge deck. Do not saw the joint by visual means such as a chalk line. Fill the holes used for holding the template or track to the deck with an approved repair material.

The joint shall be excavated using saws and pneumatic hand tools. Where possible, saws shall be set to cut the full required depth of the bituminous overlay and any membrane present. Variations in the depth of the overlay across the road should be considered to ensure, where possible, that the deck is not damaged. All debris from the excavation blockouts shall be removed to allow the full volume of new joint to be installed.

(B) Preparation of Sawed Joint for Installation

The entire blockout must be thoroughly cleaned and dried. Small debris may be removed by using compressed air. A Hot Compressed Air (HCA) Lance will then be applied throughout the length of the blockout.

Installation in concrete overlays requires sandblasting of the concrete vertical walls and adjacent deck area prior to the use of the HCA Lance application. Clean the joints by sandblasting with clean, dry sand immediately before placing the bonding agent. Sandblast the joint opening to provide a firm, clean joint surface free of curing compound, loose material, and any foreign matter. Sandblast the joint opening without causing pitting or uneven surfaces. In elastomeric concrete overlays, aggregate may be exposed after sandblasting. After sandblasting, either brush the surface with clean brushes made of hair, bristle or fiber, blow the surface with compressed air, or vacuum the surface until all traces of blast products and abrasives are removed from the surface.

If nozzle blasting is used to clean the joint opening, use compressed air that does not contain detrimental amounts of water or oil.

After cleaning the joint opening, the Engineer will thoroughly inspect the sawed joint opening for spalls, popouts, cracks, etc. All necessary repairs will be made by the Contractor prior to blast cleaning and installing the joint system, at no cost to the Department.

Spalled and defective concrete in the bridge deck shall be repaired with an approved material as directed by the Engineer prior to placing joint system materials.

(C) Plug Joint Installation

Backer rods shall be installed in expansion joint openings at a minimum of one inch depth as indicated on the plans.

The gap shall be caulked with the backer rod, allowing for the one inch of binder in the gap on top of the backer rod. Any previous caulking in place shall be removed and the surface prepared as per the manufacturer's directions for applying the new caulking. A small amount of hot binder should be placed onto the caulking to ensure that the gap is adequately plugged.

Immediately after cleaning and caulking, the entire blockouts shall be coated with a thin layer of hot binder. It shall be poured into the expansion joint openings until it runs over the edges. If significant delay occurs, the blockouts shall be inspected to determine if re-cleaning is necessary.

Binder shall be heated to a safe temperature as recommended by the manufacturer. Heating kettles shall be equipped with continuous agitation system, temperature controller, calibrated thermometer and double steel jacket with an oil layer in between, to prevent scorching of the binder. During application, the temperature of the binder shall be maintained at the minimum of 350°F.

Steel bridging plates shall be placed from curb to curb on the roadway portion of expansion joints. The gap shall be bridged with the steel plates centered over the gap by placing locating pins in the centerline of the plate and hammered in to secure plates. There must be at least two (2) inches between the edge of the steel plate and the wall of the blockouts. Once the locating pins are in place, the top of the plate shall be coated with a thin layer of hot binder.

Aggregate shall be heated in a rotating drum mixer to a minimum of 350°F or as recommended by the manufacturer. The thermoplastic polymer modified asphalt binder shall be added to the mixer to precoat aggregates.

Coated aggregates shall be placed into the blockouts in layers as recommended by the manufacturer. Blockouts shall be overfilled with coated aggregate as required to compensate for compaction. Equipment for compaction shall be as recommended by the manufacturer. Additional polymer modified asphalt binder shall be screeded over the compacted joint to fill any surface voids.

Compaction shall take place as per the manufacturer's recommendations. The joint surface shall be made approximately level with the existing road surface by using methods recommended by the manufacturer.

Top dressing aggregate shall be applied per the manufacturer's recommendations.

Vehicular traffic may pass over finished joints two hours after compaction or as recommended by the manufacturer.

In the event of work stoppage while constructing a joint, a temporary joint material pre-approved by the Engineer may be used.

The Contractor shall ensure that the entire work area is clean of debris daily, prior to departure from the jobsite.

The installed system shall be watertight and will be monitored until final inspection and approval.

(D) Watertight Integrity Test

- (1) Upon completion of each expansion joint, perform a water test on the top surface to detect any leakage. Cover the roadway section of the joint from curb to curb, or barrier rail to barrier rail, with water, either ponded or flowing, not less than 1 inch above the roadway surface at all points. Block sidewalk sections and secure an unnozzled water hose delivering approximately 1 gallon of water per minute to the inside face of the bridge railing, trained in a downward position about six (6) inches above the sidewalk, such that there is continuous flow of water across the sidewalk and down the curb face of the joint.
- (2) Maintain the ponding or flowing of water on the roadway and continuous flow across sidewalks and curbs for a period of five (5) hours. At the conclusion of the test, the underside of the joint is closely examined for leakage. The joint system is considered watertight if no obvious wetness is visible on the Engineer's finger after touching a number of underdeck areas. Damp concrete that does not impart wetness to the finger is not considered a sign of leakage.
- (3) If the joint system leaks, locate the place(s) of leakage and take any repair measures necessary to stop the leakage at no additional cost to the Department. Use repair measures recommended by the manufacturer and approved by the Engineer prior to beginning corrective work.
- (4) If measures to eliminate leakage are taken, perform a subsequent water integrity test subject to the same conditions as the original test. Subsequent tests carry the same responsibility as the original test and are performed at no additional cost to the Department.

BASIS OF PAYMENT

Asphalt Plug Joint for Preservation will be measured and paid for at the contract unit price bid per linear foot and will be full compensation for furnishing all material, labor, tools, incidentals and equipment necessary for installing the joint systems, with approval by the Engineer.

Pay Item

Asphalt Plug Joint for Preservation

Pay Unit

Linear Feet

EPOXY RESIN INJECTION

(08-08-22)

GENERAL

For repairing cracks, an applicator certified by the manufacturer of epoxy injection system to be used is required to perform the epoxy resin injection. The Contractor shall submit documentation that indicates the firm, supervisor and the workmen have completed an instruction program in the methods of restoring concrete structures utilizing the epoxy injection process and have five (5) years of relative experience with a record of satisfactory performance on similar projects.

The Contractor furnishes all materials, tools, equipment, appliances, labor and supervision required when repairing cracks with the injection of an epoxy resin adhesive.

SCOPE OF WORK

Using Epoxy Resin Injection, repair cracks 25 mils (625 μm) wide or greater in the interior bent columns and caps, in the ends of the girders, in the cantilevered portion of the ends of the girders, and in the cantilevered portion of the superstructure deck.

SUBMITTALS

Prior to construction, the Contractor shall submit the following to the Engineer for review and approval:

- (E) Materials – Information detailing the materials and their properties, storage and handling requirements, and Material Safety Data Sheets. Material certifications and sampling shall be as required as per the NCDOT *Standard Specifications* Section 106.
- (F) Injection Procedures – Preparation and epoxy injection installation procedures, including written instructions from the manufacturer of the proportioning dispenser and the procedures recommended to monitor and assure its proportioning accuracy of the unit.
- (G) Contingencies – Proposed injection repair procedures in the event that during testing it is found that the injection installation procedure did not completely fill the cracks with epoxy.
- (H) Qualifications – The resumes of the Contractor’s staff and/or the epoxy resin manufacturer’s Technical Representative that will be on site performing the epoxy injection. The resumes shall detail the installer's applicable certifications and epoxy injection installation experience.
- (I) References – The names and telephone numbers of contact persons for recent (< 2years?) epoxy injection projects.

COOPERATION

Cooperate and coordinate with the Technical Representative of the epoxy resin manufacturer for satisfactory performance of the work.

Have the material manufacturer's Technical Representative present when the epoxy resin injection process begins and until the Engineer is assured that their service is no longer needed.

The expense of having this representative on the job is the Contractor’s responsibility at no additional cost to the Department.

MATERIAL PROPERTIES

Provide a two-component structural epoxy adhesive for injection into cracks or other voids. Provide modified epoxy resin (Component “A”) that conforms to the following requirements:

Test Method	Specification Requirements
-------------	----------------------------

Viscosity @ 40 ± 3°F, cps	Brookfield RVT Spindle No. 4 @ 20 rpm	6,000 – 8,000
Viscosity @ 77 ± 3°F, cps	Brookfield RVT Spindle No. 2 @ 20 rpm	400 - 700
Epoxide Equivalent Weight	ASTM D1652	152 - 168
Ash Content, %	ASTM D482	1 max.

Provide the amine curing agent (Component “B”) used with the epoxy resin that meets the following requirements:

	Test Method	Specification Requirements
Viscosity @ 40 ± 3°F, cps	Brookfield RVT Spindle No. 2 @ 20 rpm	700 - 1400
Viscosity @ 77 ± 3°F, cps	Brookfield RVT Spindle No. 2 @ 20 rpm	105 - 240
Amine Value, mg KOH/g	ASTM D664*	490 - 560
Ash Content, %	ASTM D482	1 max.
		* Method modified to use perchloric acid in acetic acid.

Certify that the Uncured Adhesive, when mixed in the mix ratio that the material supplier specifies, has the following properties:

- Pot Life (60 gram mass)
 - @ 77 ± 3°F - 15 minutes minimum
 - @ 100 ± 3°F - 5 minutes minimum

Certify that the Adhesive, when cured for seven (7) days at 77 ± 3°F unless otherwise specified, has the following properties:

	Test Method	Specification Requirements
Ultimate Tensile Strength	ASTM D638	7,000 psi (min.)
Tensile Elongation at Break	ASTM D638	4% max.
Flexural Strength	ASTM D790	10,000 psi (min.)
Flexural Modulus	ASTM D790	3.5 x 10 ⁵ psi
Compressive Yield Strength	ASTM D695	11,000 psi (min.)
Compressive Modulus	ASTM D695	2.0 - 3.5 x 10 ⁵ psi
Heat Deflection Temperature	ASTM D648*	125°F min.

Cured 28 days @ 77 ± 3°F		135°F min.
Slant Shear Strength, 5,000 psi (34.5 MPa) compressive strength concrete	AASHTO T237	
Cured 3 days @ 40°F wet concrete		3,500 psi (min.)
Cured 7 days @ 40°F wet concrete		4,000 psi (min.)
Cured 1 day @ 77°F dry concrete		5,000 psi (min.)
* Cure test specimens so the peak exothermic temperature does not exceed 77°F.		

Use an epoxy bonding agent, as specified for epoxy mortar, as the surface seal (used to confine the epoxy resin during injection).

EQUIPMENT FOR INJECTION

Use portable positive displacement type pumps with interlock to provide positive ratio control of exact proportions of the two (2) components at the nozzle to meter and mix the two (2) injection adhesive components and inject the mixed adhesive into the crack. Use electric or air powered pumps that provide in-line metering and mixing.

Use injection equipment with automatic pressure control capable of discharging the mixed adhesive at any pre-set pressure up to 200 ± 5 psi and equipped with a manual pressure control override.

Use equipment capable of maintaining the volume ratio for the injection adhesive as prescribed by the manufacturer. A tolerance of ± 5% by volume at any discharge pressure up to 200 psi is permitted.

Provide injection equipment with sensors on both the Component A and B reservoirs that automatically stop the machine when only one component is being pumped to the mixing head.

PREPARATION

Follow these steps prior to injecting the epoxy resin:

- (A) Remove all dirt, dust, grease, oil, efflorescence and other foreign matter detrimental to the bond of the epoxy injection surface seal system from the surfaces adjacent to the cracks or other areas of application. Acids and corrosives are not permitted.
- (B) Provide entry ports along the crack at intervals determined by the Contractor to ensure full penetration of the crack.
- (C) Apply surface seal material to the face of the crack between the entry ports. For through cracks, apply surface seal to both faces.

- (D) Allow enough time for the surface seal material to gain adequate strength before proceeding with the injection.
- (E) Perform an air pressure check of the surface seal to ensure the system is airtight prior to proceeding with the injection.

EPOXY INJECTION

Before epoxy adhesive injection occurs, the Contractor shall test discharge one pint of epoxy to calibrate the equipment and to demonstrate that the workmen and equipment are working properly.

Follow approved preparation and installation procedures submitted by the Contractor. It is the Contractor's responsibility to achieve full penetration of cracks being injected.

Perform epoxy adhesive injection continuously until cracks are completely filled. Pressure shall be maintained until complete refusal of material is achieved. Any stoppage of injection for more than 15 minutes shall result in the injection equipment being cleaned, at no additional cost to the Department, before resuming injection.

If port to port travel of epoxy adhesive is not indicated, or the surface seal and/or ports become dislodged, immediately stop the work and notify the Engineer.

TESTING

The Contractor shall core 3" diameter by 6" deep samples of the cured epoxy to verify the cracks have been completely filled with epoxy. When coring, care shall be taken to avoid existing steel reinforcement, where possible. Injection will not proceed beyond the initial 50 feet until three (3) cores have been submitted to, and approved by, the Engineer. If the epoxy does not penetrate a minimum of 6" or the full depth of the crack, whichever is less, the repair will be rejected, and the contractor shall follow their proposed repair procedure that has been approved by the Engineer. The presence of the technical representative will be required when repairs begin.

The Engineer will take possession of the cores from the repaired concrete for compressive strength testing. If the failure plane is located at the repaired crack, a minimum compressive strength of 3,000 psi is required of these cores. The cost of coring is incidental to the pay item for epoxy injection. If the core fails, the contractor will be required to take corrective action before proceeding and another 50' test section will be required.

After the contractor demonstrates acceptable repairs, cores will be taken at a rate of one per 100 linear feet of repair until completion of the work or unacceptable cores are encountered.

FINISHING

When cracks are completely filled, allow the epoxy adhesive to cure for sufficient time to allow the removal of the surface seal without any draining or runback of epoxy material from the cracks.

Fill all cored holes with Type 3 grout in accordance with Section 1003 of the *Standard Specifications*.

Remove the surface seal material and injection adhesive runs or spills from concrete surfaces.

Finish the face of the crack and all core holes flush to the adjacent concrete, removing any indentations or protrusions caused by the placement of entry ports or grout placement.

BASIS OF PAYMENT

Epoxy Resin Injection will be paid at the contract unit price per linear foot. For full depth cracks, payment will be made for one side only. Such payment will be full compensation for all materials, tools, equipment, labor, coring and for all incidentals necessary to complete the work.

Pay Item	Pay Unit
Epoxy Resin Injection	Linear Foot

SHOTCRETE REPAIRS

(08-08-22)

GENERAL

The work covered by this special provision consists of removing deteriorated concrete from the structure in accordance with the limits, depth and details shown on the plans, described herein and as established by the Engineer. This work also includes removing and disposing all loose debris, cleaning and repairing reinforcing steel and applying structural shotcrete.

The location and extent of repairs shown on the plans are general in nature. The Engineer shall determine the extent of removal in the field based on an evaluation of the condition of the exposed surfaces.

Any portion of the structure that is damaged from construction operations shall be repaired to the Engineer’s satisfaction, at no extra cost to the Department.

MATERIAL REQUIREMENTS

Use prepackaged dry mix shotcrete conforming to the requirements of ASTM C1480, the applicable sections of the *Standard Specifications* and the following:

Test Description	Test Method	Age (Days)	Specified Requirements
Silica Fume (%)	ASTM C1240	-	10 (Max.)
Air Content - As Shot (%)	ASTM C231 or ASTM C457	-	5 ± 2
Minimum Compressive Strength (psi)	ASTM C109	7 28	3,000 5,000
Minimum Bond Pull-off Strength (psi)	ASTM C1583 or ASTM C882	28	250

Rapid Chloride Permeability Tests (range in coulombs)	ASTM C1202	-	100 - 1000
--	------------	---	------------

Admixtures are not allowed unless approved by the Engineer. Store shotcrete in an environment where temperatures remain above 40°F and less than 95°F

All equipment must operate in accordance with the manufacturer's specifications and material must be placed within the recommended time.

QUALITY CONTROL

(A) Qualification of Shotcrete Contractor

The shotcrete Contractor shall provide proof of experience by submitting a description of jobs similar in size and character that have been completed within the last five (5) years. The name, address and telephone number of references for the submitted projects shall also be furnished. Failure to provide appropriate documentation will result in the rejection of the proposed shotcrete contractor.

(B) Qualification of Nozzleman

The shotcrete Contractor's nozzleman shall be certified by the American Concrete Institute (ACI). Submit proof of certification to the Engineer prior to beginning repair work. The nozzleman shall maintain certification at all times while work is being performed for the Department. Failure to provide and maintain certification will result in the rejection of the proposed nozzleman.

TEMPORARY WORK PLATFORM

Prior to beginning any repair work, provide details for a sufficiently sized temporary work platform at each repair location. Design steel members to meet the requirements of the American Institute of Steel Construction Manual. Design timber members in accordance with the *National Design Specification for Stress-Grade Lumber and Its Fastenings* of the National Forest Products Association. Submit the platform design and plans for review and approval. The design and plans shall be sealed and signed by a North Carolina registered Professional Engineer. Do not install the platform until the design and plans are approved. Drilling holes in the superstructure for the purpose of attaching the platform is prohibited. Upon completion of work, remove all anchorages in the substructure and repair the substructure at no additional cost to the Department.

SURFACE PREPARATION

Prior to starting the repair operation, delineate all surfaces and areas assumed to be deteriorated by visually examining and sounding the concrete surface with a hammer or other approved method. The Engineer is the sole judge in determining the limits of deterioration.

Prior to removal, introduce a shallow saw cut approximately ½" in depth around the repair area at right angles to the concrete surface. Remove all deteriorated concrete 1 inch below the reinforcing steel with a 17 lb (maximum) pneumatic hammer with points that do not exceed the width of the

shank or with hand picks or chisels as directed by the Engineer. Do not cut or remove the existing reinforcing steel. Unless specifically directed by the Engineer, do not remove concrete deeper than 1 inch below the reinforcing steel.

Abrasive blast all exposed concrete surfaces and existing reinforcing steel in repair areas to remove all debris, loose concrete, loose mortar, rust, scale, etc. After sandblasting examine the reinforcing steel to ensure at least 90% of the original diameter remains. If there is more than 10% reduction in the rebar diameter, splice in and securely tie supplemental reinforcing bars as directed by the Engineer.

Provide stainless welded wire fabric at each repair area larger than one square foot if the depth of the repair exceeds 2 inches from the existing, intact exterior face of the concrete member. Provide a minimum 4" x 4" - 12 gage stainless welded wire fabric unless otherwise shown on the plans. Rigidly secure the welded wire fabric to existing steel or to $\frac{3}{16}$ " diameter stainless hook fasteners adequately spaced to prevent sagging. Encase the welded wire fabric in shotcrete a minimum depth of 1½ inches.

With the exception of overhead applications, the contractor has the option to use synthetic fiber reinforcement as an alternate to welded wire fabric if attaching welded wire fabric is impractical or if approved by the Engineer. Welded wire fabric and synthetic fiber reinforcement shall not be used in the same repair area.

Thoroughly clean the repair area of all dirt, grease, oil or foreign matter, and remove all loose or weakened material before applying shotcrete. Saturate the repair area with clean water the day before applying shotcrete. Bring the wetted surface to a saturated surface dry (SSD) condition prior to applying shotcrete and maintain this condition until the application begins. Use a blowpipe to facilitate removal of free surface water. Only oil-free compressed air is to be used in the blowpipe.

The time between removal of deteriorated concrete and applying shotcrete shall not exceed five (5) calendar days. If the time allowance exceeds (5) calendar days, prepare the surface at the direction of the Engineer before applying shotcrete.

APPLICATION AND SURFACE FINISH

Apply shotcrete only when the surface temperature of the repair area is greater than 40°F and less than 95°F. Do not apply shotcrete to frosted surfaces. Maintain shotcrete at a minimum temperature of 40°F for three (3) calendar days after placement.

Apply shotcrete in layers. The properties of the applied shotcrete determine the proper thickness of each layer or lift.

The nozzleman should hold the nozzle three (3) to four (4) feet from the surface being covered in a position that ensures the shotcrete strikes at right angles to the surface being covered without excessive impact. The nozzleman shall maintain the water amount at a practicable minimum, so the mix properly adheres to the repair area. Water content should not become high enough to cause the mix to sag or fall from vertical or inclined surfaces, or to separate in horizontal layers.

Use shooting wires or guide strips that do not entrap rebound sand. Use guide wires to provide a positive means of checking the total thickness of the shotcrete applied. Remove the guide wires prior to the final finish coat.

To avoid leaving sand pockets in the shotcrete, blow or rake off sand that rebounds and does not fall clear of the work, or which collects in pockets in the work. Do not reuse rebound material in the work.

If a work stoppage longer than two (2) hours takes place on any shotcrete layer prior to the time it has been built up to required thickness, saturate the area with clean water and use a blowpipe as outlined previously, prior to continuing with the remaining shotcrete course. Do not apply shotcrete to a dry surface.

Finish all repaired areas, including chamfered edges, as close as practicable to their original dimensions and configuration, unless otherwise required to provide a minimum 2" of cover for reinforcing steel exposed during repair. If necessary to extend shotcrete repair material beyond the original member dimensions and geometry, coordinate with the Engineer to determine methods, geometry, and dimensions of the final finished surface to provide a minimum 2" of cover on reinforcing steel. Slightly build up and trim shotcrete to the final surface by cutting with the leading edge of a sharp trowel. Use a rubber float to correct any imperfections. Limit work on the finished surface to correcting imperfections caused by trowel cutting.

Immediately after bringing shotcrete surfaces to final thickness, thoroughly check for sags, bridging, and other deficiencies. Repair any imperfections at the direction of the Engineer.

Cure the completed shotcrete surface in accordance with Article 420-15(B) Water Method, of the *Standard Specifications* for seven (7) calendar days. If the water method is impracticable and if approved by the Engineer, a membrane curing compound may be used in accordance with Sub article 420-15(C) at double the manufacturer's recommended coverage rate.

MATERIAL TESTING & ACCEPTANCE

Each day shotcreting takes place, the nozzleman shall shoot one 18" x 18" x 3.5" test panel in the same position as the repair work that is being done to demonstrate the shotcrete is being applied properly. Store, handle and cure the test panel in the same manner as the repaired substructure and do not disturb for the first 24 hours after shotcreting.

Approximately 72 hours after completing the final shotcrete placement, thoroughly test the surface with a hammer. At this time, the repair area should have sufficient strength for all sound sections to ring sharply. Remove and replace any unsound portions prior to the final inspection of the work. No additional compensation will be provided for removal and replacement of unsound shotcrete.

In accordance with Sub article 1002-3(H) of the *Standard Specifications*, core three (3) 3" diameter samples from each test panel. Compressive strength values on test panels shall equal or exceed the required 28-day strength requirements. Should failures occur on the test panel cores, acceptance of the material will be determined by tests on cores from the installed work on the structure. A minimum of (3) three cores shall be taken from the area in question of the structure. The average compressive strength of the cores taken from the structure shall equal or exceed the specified

strength of the shotcrete applied, and no single core shall have strength less than 85% of the specified value. Any cores taken from the structure shall penetrate into the existing concrete at least two (2) inches. Cores shall also be inspected for delamination, sand pockets, segregation, and voids.

The adequacy of the bond between the existing concrete and the shotcrete shall be determined by direct tension bond testing, in accordance with ASTM C1583 or ASTM C882, as directed by the Engineer. A minimum bond strength of 250 psi will be accepted as satisfactory. Bond failure less than 250 psi attributable to the failure of existing concrete will not be cause for rejection. The cost of up to three passing direct tension bond tests shall be the responsibility of the Contractor; additional passing pull-off tests will be the responsibility of the Department.

Any repair work failing to meet the requirements of this provision will be rejected and the Contractor shall implement a remediation plan to correct the deficiency at no additional cost to the Department. No extra payment will be provided for drilling extra cores. Patch all core holes in the repaired structure to the satisfaction of the Engineer.

MEASUREMENT AND PAYMENT

Shotcrete Repairs will be measured and paid for at the contract unit price bid per cubic foot and will be full compensation for removal, containment and disposal off-site of unsound concrete including the cost of materials, labor, tools, equipment and incidentals necessary to complete the repair work. Depth will be measured from the original outside concrete face. If modifications to the dimensions and geometry are approved by the Engineer to achieve proper clearance over reinforcing steel, depth measurements will be made from the modified final outside face. The Contractor and Engineer will measure quantities after removal of unsound concrete and before application of repair material. Payment will also include the cost of sandblasting, surface cleaning and preparation, cleaning of reinforcing steel, placement of new steel, cost of temporary work platform, testing for soundness and bond strength, curing of shotcrete and taking core samples from the test panels and the structure.

Payment will be made under:

Pay Item	Pay Unit
Shotcrete Repairs	Cubic Feet

CONCRETE REPAIRS

(2-11-19)

DESCRIPTION

Work includes removal of concrete in spalled, delaminated and/or cracked areas of the existing bent caps, bent columns, underside of bridge decks, deck slabs, girders, and bridge rails in reasonably close conformity with the lines, depth, and details shown on the plans, described herein and as established by the Engineer. This work also includes straightening, cleaning, and replacement of reinforcing steel, doweling new reinforcing steel, removing all loose materials, removing and disposing of debris, formwork, applying repair material, and protecting adjacent

areas of the bridge and environment from material leakage. The repair material shall be one of the materials described in this Special Provision, unless otherwise noted in the plans or special provisions.

The location and extent of repairs shown on the plans described herein are general in nature. The Engineer shall determine the extent of removal in the field based on an evaluation of the condition of the exposed surfaces. The Contractor shall coordinate removal operations with the Engineer. No more than 30% of a round or square column or 30% of the bearing area under a beam shall be removed without a temporary support system and approval from the Engineer.

Repair, to the Engineer's satisfaction, any portion of the structure that is damaged from construction operations. No extra payment is provided for these repairs.

SURFACE PREPARATION

Adhere to the following surface preparation requirements or the repair material manufacturer's requirements, whichever is more stringent.

Prior to starting the repair operation, delineate all surfaces and areas assumed to be deteriorated by visually examining and sounding the concrete surface with a hammer or other approved method. The Engineer is the sole judge in determining the limits of deterioration.

Prior to concrete removal, introduce a shallow saw cut, ½" in depth, around the repair area at right angles to the concrete surface. Sawcut should be located a minimum 2" beyond the perimeter of the deteriorated concrete area to be repaired. Remove all concrete within the sawcut to a minimum depth of ½". If concrete removal exposes reinforcing steel, remove all deteriorated concrete 1" below the reinforcing steel with a 17 lb (maximum) pneumatic hammer, with points that do not exceed the width of the shank, or with hand picks or chisels, as directed by the Engineer. Do not cut or remove the existing reinforcing steel. Unless specifically directed by the Engineer, do not remove concrete deeper than 1" below the reinforcing steel.

Abrasive blast all exposed concrete surfaces and existing reinforcing steel in repair areas to remove all debris, loose concrete, loose mortar, rust, scale, etc. After blasting, examine the reinforcing steel to ensure at least 90% of the original diameter remains. If there is more than 10% reduction in the rebar diameter, splice in and securely tie supplemental reinforcing bars as directed by the Engineer. This might require additional removal of concrete, in order to achieve an appropriate splice length of the reinforcing steel.

Thoroughly clean the repair area of all dirt, grease, oil, or foreign matter, and remove all loose or weakened material by abrasive blasting before applying concrete repair material. Acid etch with 15% hydrochloric acid, only if approved by the Engineer. Follow acid etching by scrubbing and flushing with copious amounts of clean water. Check the cleaning using moist pH paper. Water cleaning is complete when the paper reads ten (10) or higher.

Follow all abrasive blasting with vacuum cleaning.

The time between removal of deteriorated concrete and applying concrete repair material shall not exceed 72 hours. If the time allowance exceeds 72 hours, prepare the surface at the direction of the Engineer before applying concrete repair material.

APPLICATION AND SURFACE FINISH

Apply repair material to damp surfaces only when allowed by repair material recommendations and approved by the Engineer. Prepare damp surfaces in accordance with the *Standard Specifications* and/ or repair material manufacturer's recommendations. Use a blowpipe to facilitate removal of free surface water. Only oil-free compressed air is to be used in the blowpipe.

When surface preparation is completed, mix and apply repair material in accordance with the *Standard Specifications* and/ or repair material manufacturer's recommendations.

Use aggregate that is washed, kiln-dried, and bagged. Maximum size of aggregate shall not exceed 2/3 of the minimum depth of the repair area, or 3/4 of the depth of excavation behind the reinforcing steel, whichever is smaller.

Unless otherwise required by the repair material manufacturer, apply bonding agent to all repair areas immediately prior to placing repair material.

Repair areas shall be formed unless otherwise approved by the Engineer. Form and finish all repaired areas, including chamfered edges, as close as practicable to their original "As Built" dimensions and configuration. After applying the repair material, remove excessive material and provide a smooth, flush surface, unless directed otherwise.

Cure finished Class A concrete repair material by maintaining 95% relative humidity at the repair and surrounding areas by fogging, moist curing, or other approved means for seven (7) days. Cure polymer modified concrete repair material in accordance with manufacturer's recommendations.

REPAIR MATERIAL OPTIONS

(A) Polymer Modified Concrete Repair Material

Repair material shall be polymer modified cement mortar for vertical or overhead applications and shall be suitable for applications in marine environments. Material shall be approved for use by NCDOT. Submit repair material to the Engineer for review and approval prior to beginning the work. Color of repair material shall be concrete gray.

(B) Class A Concrete Repair Material

Repair material shall be Class A Portland Cement Concrete as described in Article 1000-4 of the *Standard Specifications*.

TEMPORARY WORK PLATFORM

Prior to beginning any repair work, provide details for a sufficiently sized temporary work platform at each repair location. Design steel members to meet the requirements of the *American Institute of Steel Construction Manual*. Design timber members in accordance with the *National Design*

Specification for Stress-Grade Lumber and Its Fastenings of the National Forest Products Association. Submit the platform design and plans for review and approval. The design and plans shall be sealed and signed by a North Carolina registered Professional Engineer. Do not install the platform until the design and plans are approved. Drilling holes in the superstructure for the purpose of attaching the platform is prohibited. Upon completion of work, remove all anchorages in the substructure and repair the substructure at no additional cost to the Department.

MEASUREMENT AND PAYMENT

Concrete Repairs will be measured and paid for at the contract unit price bid per cubic foot and will be full compensation for removal, containment and disposal off-site of unsound concrete including the cost of materials, reinforcing steel, labor, tools, equipment and incidentals necessary to complete the repair work. Depth will be measured from the original outside concrete face. The Contractor and Engineer will measure quantities after removal of unsound concrete and before application of repair material. Payment will also include the cost of abrasive blasting, surface cleaning and preparation, blast cleaning of reinforcing steel, placement of new reinforcing steel, cost of temporary work platform, testing of the soundness of the exposed concrete surface, furnishing and installation of repair mortar material, curing and sampling of concrete, and protection/cleaning of adjacent areas from splatter or leakage.

Reinforcing Steel that is required for the repairs will be in accordance with Section 425 of the *Standard Specifications*.

Payment will be made under:

Pay Item	Pay Unit
Concrete Repairs	Cubic Feet

VOLUMETRIC MIXER

(12-18-12)

DESCRIPTION

This provision addresses the requirements for batching deck repair concrete at the point of delivery using a Mobile High Performance Volume Mixer (MHPVM). Work shall be in accordance with the general requirements of Section 1000-12 of the *Standard Specifications* and as amended by these provisions.

MATERIALS

Produce high early strength concrete with MHPVM equipment. Furnish project site storage facilities that will provide protection of materials in accordance with the *Standard Specifications* and all material suppliers' recommendations.

EQUIPMENT

MHPVM devices shall have prominently displayed stamped metal plate(s) from the Volumetric Mixers Manufacturers Bureau stating that the equipment conforms to the requirements of ASTM C685.

Hydraulic cement concrete shall be mixed at the point of delivery by a combination of materials and mixer unit conforming to the following:

- 1.) The unit shall be equipped with calibrated proportioning devices for each ingredient added to the concrete mix. The unit shall be equipped with a working recording meter that is visible at all times and furnishes a ticket printout with the calibrated measurement of the mix being produced. If at any time the mixer fails to discharge a uniform mix, production of concrete shall be suspended until such time that problems are corrected.
- 2.) Each unit shall have prominently displayed stamped metal plate(s) attached by the manufacturer on which the following are plainly marked: the gross volume of the transportation unit in terms of mixed concrete, the discharge speed and the mass calibrated constant of the machine in terms of volume.
- 3.) MHPVMs shall be calibrated by a Department approved testing agency in accordance with the manufacturer's recommendations at an interval of every 6 months or a maximum production of 2500 cubic yards, whichever comes first prior to use on the project. The yield shall be maintained within a tolerance of +/- 1% and verified using a minimum 2 cubic feet container every 500 cubic yards or a minimum of once per week.
- 4.) The three cubic feet initially discharged from the truck shall be discarded and not used for concrete placement. Acceptance of the concrete shall comply with the Standard Specifications except that the sample secured for acceptance testing will be taken after four cubic feet is discharged from the delivery vehicle. During discharge, the consistency as determined by ASTM C143 on representative samples taken from the mixer discharge at random intervals shall not vary by more than 1 inch. Acceptance tests shall be performed on each load. If test data demonstrates that acceptable consistency of concrete properties is being achieved, the Engineer may reduce testing requirements.
- 5.) MHPVM equipment shall be operated by a person who is a certified operator by the equipment manufacturer. Any equipment adjustments made during the on-site production of concrete shall be done under the direct on-site supervision of the producer's NCDOT Certified Concrete Batch Technician.

UNIFORMITY AND ACCEPTANCE

The contractor is responsible for providing a Certified Concrete Plant Technician during batching operations, and a Certified Concrete Field Technician during placing operations

MEASUREMENT AND PAYMENT

Volumetric Mixer will be paid for as lump sum and will be full compensation for furnishing the certified MHPVM devices and calibration of the equipment.

Pay Item

Volumetric Mixer

Pay Unit

Lump Sum

SPECIAL PROVISIONS FOR PROTECTION OF RAILROAD INTEREST

Under the terms of these provisions, the North Carolina Department of Transportation shall hereinafter be called “Sponsor”, and CSX Transportation, Inc. shall hereinafter be called “Railroad”.

The attached **CSXT Special Provisions, CSXT Construction Submission Criteria, CSXT Insurance Requirements for Public Projects, and CSX Transportation, Inc. Temporary Right of Entry Agreement** for this project, as may be modified herein compared to those found in the CSX Transportation *Public Projects Information Manual For Construction and Improvement Projects That May Involve the Railroad* to be project-specific, and the attached project-specific Construction Requirements shall serve as the basis for the Railroad provisions of this contract. The following additional statements are to be included as addenda to the attached provisions:

- Requirements throughout these provisions placed on “Agency or its Contractor” shall be the sole responsibility of the Contractor unless specifically stated otherwise elsewhere within these provisions. All contractor costs for railroad coordination shall be considered incidental to the other pay items.
- Unless noted elsewhere in these provisions, all contact with Railroad should be addressed to the below individual who shall be considered the CSXT Representative.

Jason Field
Moffatt and Nichol
(919) 645-0639 (Direct)
(919) 271-3986 (Mobile)
JField@moffattnichol.com

- The Engineer shall be considered the Agency Representative.
- All required work plan submissions for each phase of the project shall be forwarded to and accepted in writing by the Railroad prior to proceeding with the work of that phase. Up to thirty (30) days will be required to review each submission. Up to an additional thirty (30) days will be required to review each subsequent submission returned not marked “Conforms As Noted”.
- The Contractor shall be responsible to have painted on the structures the respective Crossing Numbers assigned to the existing project bridges over the CSXT Mileposts as indicated below:
 - 770454, Railroad MP SE-274.600, Crossing No. 973585N
 - 770455, Railroad MP SE-274.600, Crossing No. 973584G
 - 770456, Railroad MP AG-245.940, Crossing No. 938183P
 - 770457, Railroad MP AG-245.920, Crossing No. 938182HThese numbers shall be affixed at a location on either side of the CSXT tracks or property and in a manner such that it can be readily discerned and visible from track level. The font size of the DOT # numbers and letter should be at least four inches (4”) tall and shall be black

on a light-colored background or white on a dark-colored background of the grade separation component.

- CSXT Special Provisions Section VI.A – The following paragraph shall be added as the second paragraph:

The Department will bear all railroad costs incidental to such crossings including flagging and services performed by Railroad personnel. Written approval from the Engineer is required prior to use of the crossings. The Contractor shall sequence construction to minimize the duration the crossing(s) remain in-place. The Contractor shall reimburse the Department for any costs of the flagging for the crossing outside of the duration approved by the Engineer. Cost of the installation, maintenance and removal of the temporary crossing(s) incurred by the Contractor will be considered incidental to the other pay items.

- CSXT Special Provisions Section XII.C – Flagging or monitoring requests should be made to RRFlagging@Moffattnichol.com. Termination or cancellation of flagger requires ten (10) days' written notice to avoid incurring costs.

- CSXT Special Provisions Section XII.D – The following paragraph shall be added as the second paragraph:

Should violations of Railroad policy or unscheduled, unauthorized work by the Contractor result in additional full time flagging being required by the Railroad, the additional cost of such flagging above normal flagging cost shall be deducted from the final payment to the Contractor as provided in Article 109-9 of the Standard Specifications. Neither Department nor Railroad will be liable for damages resulting from unscheduled or unauthorized work.

- CSXT Special Provisions Section XII.E – Include the following sentence at the end of the paragraph:

The Contractor shall reimburse the Department for any costs of the flagging which is required for work for the benefit of the Contractor.

- CSXT Insurance Requirements for Public Projects Section I.4.d – The Project Description and Designation on the Declarations shall read:

Maxton, Robeson County, North Carolina, Preservation of Bridges 770454, 770455, 770456, and 770457 on US 74 over CSXT, Carolinas Division, Wilmington Subdivision, CSXT OP# NC1127; State# HI-0017

- CSXT Insurance Requirements for Public Projects Section II.1 – Insurance documents shall be submitted to the Sponsor at the following address:

NCDOT Rail Division
Engineering & Safety Branch
C/O State Railroad Agent
1556 Mail Service Center
Raleigh, NC 27699-1556

- The Contractor shall not commence any work on railroad rights-of-way until a fully executed copy of the attached CSX Transportation Inc. Temporary Right of Entry Agreement has been received and all other requirements of these provisions for commencement of work have been completed.
- The Contractor will be responsible to obtain from CSXT any easements required by CSXT for the performance of the work based on the Contractor's proposed site access plan and means and methods. Construction shall not commence until such time that the easements have been recorded and receipt of the associated fees have been acknowledged by CSXT.
- Construction shall not commence until such time that a license agreement between CSXT and the Town of Spruce Pine for the existing overhead bridge is in place and receipt of the associated fees have been acknowledged by CSXT.
- Train Data

Bridge	Milepost	Crossing #	Trains/ Day	Speed	No. of Tracks
770454	SE-274.600	973585N	2	10	1
770455	SE-274.600	973584G	2	10	1
770456	AG-245.940	938183P	1	10	1
770457	AG-245.920	938182H	1	10	1

APPENDIX

CSX TRANSPORTATION

CSX SPECIAL PROVISIONS

DEFINITIONS:

As used in these Special Provisions, all capitalized terms shall have the meanings ascribed to them by the Agreement, and the following terms shall have the meanings ascribed to them below:

“CSX” shall mean CSX Transportation, Inc., its successors and assigns.

“CSX Representative” shall mean the authorized representative of CSX Transportation, Inc.

“Agreement” shall mean the Agreement between CSX and Agency dated as of _____, 20__ amended from time to time.

“Agency” shall mean the _____, _____

“Agency Representative” shall mean the authorized representative of _____, _____

“Contractor” shall have the meaning ascribed to such term by the Agreement.

“Work” shall mean the Project as described in the Agreement.

I. AUTHORITY OF CSX ENGINEER

The CSX Representative shall have final authority in all matters affecting the safe maintenance of CSX operations and CSX property, and his or her approval shall be obtained by the Agency or its Contractor for methods of construction to avoid interference with CSX operations and CSX property and all other matters contemplated by the Agreement and these Special Provisions.

II. INTERFERENCE WITH CSX OPERATIONS

A. Agency or its Contractor shall arrange and conduct its work so that there will be no interference with CSX operations, including, but not limited to: train, signal, telephone and telegraphic services, or damage to CSX’s property, or to poles, wires, and other facilities of tenants on CSX’s Property or right-of-way. Agency or its Contractor shall store materials so as to prevent trespassers from causing damage to trains, or CSX Property. Whenever Work is likely to affect the operations or safety of trains, the method of doing such Work shall first be submitted to the CSX Representative for approval, but such approval shall not relieve Agency or its Contractor from liability in connection with such Work.

B. If conditions arising from or in connection with the Project require that immediate and unusual provisions be made to protect train operation or CSX’s property, Agency or its Contractor shall make such provision. If the CSX Representative determines that such provision is insufficient, CSX may, at the expense of Agency or its Contractor, require or provide such provision as may be deemed necessary, or cause the Work to cease immediately.

C. Should work activities be required within CSX property or right-of-way, the Contractor shall request CSX to locate any buried utilities or facilities (air lines, wells, etc.). A written request shall be delivered to the CSX Representative at least five (5) days in advance. The traditional “One Call” utility locate services are not responsible for locating any CSX undergrade utilities or facilities.

III. INSURANCE

The Contractor shall not be permitted to work on, or have potential to foul, CSX property or right-of-way until CSX has acknowledged written acceptance of the insurance coverages for the proposed project. See PAGE 16 - INSURANCE REQUIREMENTS.

IV. NOTICE OF STARTING WORK

Agency or its Contractor shall not commence any work on CSX Property or rights-of-way until it has complied with the following conditions:

- A. Notify CSX in writing of the date that it intends to commence Work on the Project. Such notice must be received by CSX at least ten (10) business days in advance of the date Agency or its Contractor proposes to begin Work on CSX property. The notice must refer to this Agreement by date. If flagging service is required, such notice shall be submitted at least thirty (30) business days in advance of the date scheduled to commence the Work.
- B. Obtain authorization, through the Notice to Proceed, from the CSX Representative to begin Work on CSX property. Once authorization is given, Agency or Contractor shall provide a detailed schedule to include means and methods for review, comment and/or approval prior to commencement of work. CSX will in turn provide direction regarding specific conditions with which it must comply.
- C. Obtain from CSX the names, addresses and telephone numbers of CSX's personnel who must receive notice under provisions in the Agreement. Where more than one individual is designated, the area of responsibility of each shall be specified.

V. WORK FOR THE BENEFIT OF THE CONTRACTOR

- A. No temporary or permanent changes to wire lines or other facilities (other than third party fiber optic cable transmission systems) on CSX property that are considered necessary to the Work are anticipated or shown on the Plans. If any such changes are, or become, necessary in the opinion of CSX or Agency, such changes will be covered by appropriate revisions to the Plans and by preparation of a force account estimate. Such force account estimate may be initiated by either CSX or Agency, but must be approved by both CSX and Agency. Agency or Contractor shall be responsible for arranging for the relocation of the third party fiber optic cable transmission systems, at no cost or expense to CSX.
- B. Should Agency or Contractor desire any changes in addition to the above, then it shall make separate arrangements with CSX for such changes to be accomplished at the Agency or Contractor's expense.

VI. HAUL ACROSS RAILROAD

A. If Agency or Contractor desires access across CSX property or tracks at other than an existing and open public road crossing in or incident to construction of the Project, the Agency or Contractor must first obtain the permission of CSX and shall execute a license agreement or right of entry satisfactory to CSX, wherein Agency or Contractor agrees to bear all costs and liabilities related to such access.

- 1. Temporary construction haul roads across CSX tracks will require a separate application and payment to CSX Property Services. Agreement extensions require additional payment. Actual cost is variable and project specific. Additional information can be found at this URL: <https://www.csx.com/index.cfm/customers/value-added-services/property-real-estate/permitting-utility-installations-and-rights-of-entry/>.

B. Agency and Contractor shall not cross CSX's property and tracks with vehicles or equipment of any kind or character, except at such crossing or crossings as may be permitted pursuant to this section.

VII. COOPERATION AND DELAYS

A. Agency or Contractor shall arrange a schedule with CSX for accomplishing stage construction involving work by CSX. In arranging its schedule, Agency or Contractor shall ascertain, from CSX, the lead time required for assembling crews and materials and shall make due allowance therefor.

B. Agency or Contractor may not charge any costs or submit any claims against CSX for hindrance or delay caused by railroad traffic; work done by CSX or other delay incident to or necessary for safe maintenance of railroad traffic; or for any delays due to compliance with these Special Provisions.

C. Agency and Contractor shall cooperate with others participating in the construction of the Project to the end that all work may be carried on to the best advantage.

D. Agency and Contractor understand and agree that CSX does not assume any responsibility for work performed by others in connection with the Project. Agency and Contractor further understand and agree that they shall have no claim whatsoever against CSX for any inconvenience, delay or additional cost incurred by Agency or Contractor on account of operations by others.

VIII. STORAGE OF MATERIALS AND EQUIPMENT

Agency and Contractor shall not store their materials or equipment on CSX's property or where they may potentially interfere with CSX's operations, unless Agency or Contractor has received CSX Representative's prior written permission. Agency and Contractor understand and agree that CSX will not be liable for any damage to such materials and equipment from any cause and that CSX may move, or require Agency or Contractor to move, such material and equipment at Agency's or Contractor's sole expense. To minimize the possibility of damage to the railroad tracks resulting from the unauthorized use of equipment, all grading or other construction equipment that is left parked near the tracks unattended by watchmen shall be immobilized to the extent feasible so that it cannot be moved by unauthorized persons.

IX. CONSTRUCTION PROCEDURES

A. General

1. Construction work on CSX property shall be subject to CSX's inspection and approval.
2. Construction work on CSX property shall be in accord with CSX's Construction Submission Criteria, latest edition and CSX's written outline of specific conditions and with these Special Provisions.
3. Contractor shall observe the terms and rules of the CSX Safe Way manual, which Agency and Contractor shall be required to obtain from CSX, and in accord with any other instructions furnished by CSX or CSX's Representative. Failure to comply with the terms of the agreement and CSX rules can result in mandatory railroad worker protective training for the Agency, Contractor and its subcontractors.

B. Blasting

1. Agency or Contractor shall obtain CSX Representative's and Agency Representative's prior written approval for use of explosives on or adjacent to CSX property. If permission for use of explosives is granted, Agency or Contractor must comply with the following:

- a. Blasting shall be done with light charges under the direct supervision of a responsible officer or employee of Agency or Contractor.
- b. Electric detonating fuses shall not be used because of the possibility of premature explosions resulting from operation of two-way train radios.
- c. No blasting shall be done without the presence of an authorized representative of CSX. At least thirty (30) days' advance notice to CSX Representative is required to arrange for the presence of an authorized CSX representative and any flagging that CSX may require.
- d. Agency or Contractor must have at the Project site adequate equipment, labor and materials, and allow sufficient time, to (i) clean up (at Agency's expense) debris resulting from the blasting without any delay to trains; and (ii) correct (at Agency's expense) any track misalignment or other damage to CSX's property resulting from the blasting, as directed by CSX Representative, without delay to trains. If Agency's or Contractor's actions result in delay of any trains, including Amtrak passenger trains, Agency shall bear the entire cost thereof.
- e. Agency and Contractor shall not store explosives on CSX property.

2. CSX Representative will:

- a. Determine the approximate location of trains and advise Agency or Contractor of the approximate amount of time available for the blasting operation and clean-up.
- b. Have the authority to order discontinuance of blasting if, in his or her opinion, blasting is too hazardous or is not in accord with these Special Provisions.

X. ENVIRONMENTAL

A. Should soil excavation within CSX property be anticipated and said soils cannot remain on CSX property during and after construction, then CSX Environmental must be contacted at least thirty (30) days in advance of the work in order to schedule sampling, classification and disposition of material. Excavated material is prohibited from being removed from CSX property, or rights-of-way, without expressed written direction from CSX. Should final disposition require disposal of excavated material, CSX shall have sole discretion of means and location of said disposal. The project sponsor or Agency will bear all costs associated with sampling, staging and subsequent disposal if deemed necessary. Contractor will be required to obtain all disposal tickets / documentation and provide the information to the CSX Representative. CSX will not bear any costs associated with this work.

B. Any waste materials generated by the Project, including but not limited to washing with cleaning solvents, blasting, scraping, brushing and painting operations, shall be the responsibility of the Agency or its Contractor and shall be contained, collected and properly disposed of by the Agency or its Contractor. Agency and its Contractor agree to fully comply with all federal, state, and local environmental laws, regulations, statutes and ordinances at all times.

XI. MAINTENANCE OF DITCHES ADJACENT TO CSX TRACKS

Agency or Contractor shall maintain all ditches and drainage structures free of silt or other obstructions that may result from their operations. In addition, Agency or Contractor shall maintain all CSX property or right-of-way impacted by project operations including but not limited to; access or haul roads, staging areas, parking lots in a manner that provides CSX free and clear access to facilities, materials while providing acceptable driving surfaces free of drainage impacts or reduced CSX capacity. Agency or Contractor shall provide erosion control measures during construction and use methods that accord with applicable state standard specifications for road and bridge construction, including either (1) silt fence; (2) hay or straw barrier; (3) berm or temporary ditches; (4) sediment basin; (5) aggregate checks; and (6) channel lining. All such maintenance and repair of damages due to Agency's or Contractor's operations shall be performed at Agency's expense.

XII. TRACK PROTECTION / INSPECTION SERVICE

A. CSX has sole authority to determine the need for track protection required to protect its operations and property. In general, track protection will be required whenever Agency or Contractor or their equipment are, or are likely to be, working within fifty (50) feet of live track or other track clearances specified by CSX, or over tracks.

B. Agency shall reimburse CSX directly for all costs of track protection that is required on account of construction within CSX property shown in the Plans, or that is covered by an approved plan revision, supplemental agreement or change order.

C. Agency or Contractor shall give a minimum of thirty (30) days' advance notice to CSX Representative for anticipated need for track protection. No work shall be undertaken until the flag person(s) is/are at the job site. If it is necessary for CSX to advertise a flagging job for bid, it may take up to ninety (90) days to obtain this service and CSX shall not be liable for the cost of delays attributable to obtaining such service.

D. CSX shall have the right to assign an individual to the site of the Project to perform inspection service whenever, in the opinion of CSX Representative, such inspection may be necessary. Agency shall reimburse CSX for the costs incurred by CSX for such inspection service. Inspection service shall not relieve Agency or Contractor from liability.

E. CSX shall render invoices for, and Agency shall pay for, the actual pay rate of the flagpersons and inspectors used, plus standard additives, whether that amount is above or below the rate provided in the Estimate. If the rate of pay that is to be used for inspector or flagging service is changed before the work is started or during the progress of the work, whether by law or agreement between CSX and its employees, or if the tax rates on labor are changed, bills will be rendered by CSX and paid by Agency using the new rates. Agency and Contractor shall perform their operations that require track protection or inspection service in such a manner and sequence that the cost of such will be as economical as possible.

XIII. UTILITY FACILITIES ON CSX PROPERTY

Agency shall arrange, upon approval from CSX, to have any utility facilities on or over CSX Property changed as may be necessary to provide clearances for the proposed trackage.

XIV. CLEAN-UP

Agency or Contractor, upon completion of the Project, shall remove and dispose from CSX's Property any temporary construction work, any temporary erosion control measures used to control drainage, all machinery, equipment, surplus materials, falsework, rubbish, or temporary buildings belonging to Agency or Contractor. Agency or Contractor, upon completion of the Project, shall leave CSX Property in neat condition, satisfactory to the CSX Representative.

XV. FAILURE TO COMPLY

If Agency or Contractor violate or fail to comply with any of the requirements of these Special Provisions, (a) CSX may require Agency and/or Contractor to vacate CSX Property; and (b) CSX may withhold monies due Agency and/or Contractor; (c) CSX may require Agency to withhold monies due Contractor; and (d) CSX may cure such failure and the Agency shall reimburse CSX for the cost of curing such failure.

EXHIBIT F

INSURANCE REQUIREMENTS

I. Insurance Policies

Agency and Contractor, if and to the extent that either is performing work on or about CSX's property, shall procure and maintain the following insurance policies:

1. Commercial General Liability coverage at their sole cost and expense with limits of not less than \$5,000,000 in combined single limits for bodily injury and/or property damage per occurrence, and such policies shall name CSX as an additional named insured.
2. Statutory Worker's Compensation and Employers Liability Insurance with limits of not less than \$1,000,000, which insurance must contain a waiver of subrogation against CSX and its affiliates (if permitted by state law).
3. Commercial automobile liability insurance with limits of not less than \$1,000,000 combined single limit for bodily injury and/or property damage per occurrence, and such policies shall name CSX as an additional named insured.
4. Railroad protective liability insurance with limits of not less than \$5,000,000 combined single limit for bodily injury and/or property damage per occurrence and an aggregate annual limit of \$10,000,000, which insurance shall satisfy the following additional requirements:
 - a. The Railroad Protective Insurance Policy must be on the ISO/RIMA Form of Railroad Protective Insurance - Insurance Services Office (ISO) Form CG 00 35.
 - b. CSX Transportation must be the named insured on the Railroad Protective Insurance Policy.
 - c. Name and Address of Contractor and Agency must appear on the Declarations page.
 - d. Description of operations must appear on the Declarations page and must match the Project description.
 - e. Authorized endorsements must include the Pollution Exclusion Amendment - CG 28 31, unless using form CG 00 35 version 96 and later.
 - f. Authorized endorsements may include:
 - (i). Broad Form Nuclear Exclusion - IL 00 21
 - (ii) 30-day Advance Notice of Non-renewal or cancellation
 - (iii) Required State Cancellation Endorsement
 - (iv) Quick Reference or Index - CL/IL 240
 - g. Authorized endorsements may not include:
 - (i) A Pollution Exclusion Endorsement except CG 28 31
 - (ii) A Punitive or Exemplary Damages Exclusion
 - (iii) A "Common Policy Conditions" Endorsement
 - (iv) Any endorsement that is not named in Section 4 (e) or (f) above.
 - (v) Policies that contain any type of deductible

5. All insurance companies must be A. M. Best rated A- and Class VII or better.
6. The CSX OP number or CSX contract number, as applicable, must appear on each Declarations page and/or certificates of insurance.
7. Such additional or different insurance as CSX may require.

II. Additional Terms

1. Contractor must submit the complete Railroad Protective Liability policy, Certificates of Insurance and all notices and correspondence regarding the insurance policies in an electronic format to:

Insurance Department
CSX Transportation, Inc.
500 Water Street, C-907
Jacksonville, FL 32202

OR

insurancedocuments@csx.com

2. Neither Agency nor its Designee may begin work on or about CSX property until written approval of the required insurance has been received from CSX or CSX's Insurance Compliance vendor, Ebix.

APPENDIX

CSX TRANSPORTATION

CONSTRUCTION SUBMISSION CRITERIA

INTRODUCTION

SECTION I: Definitions

SECTION II: Construction Submissions

SECTION III: Hoisting Operations

SECTION IV: Demolition Procedure

SECTION V: Erection Procedure

SECTION VI: Temporary Excavation and Shoring

SECTION VII: Track Monitoring

INTRODUCTION

The intent of this document is to guide outside agencies and their Contractors when performing work on, over, or with potential to impact CSX property (ROW). Work plans shall be submitted for review to the designated CSX Engineering Representative for all work which presents the potential to affect CSX property or operations; this document shall serve as a guide in preparing these work plans. All work shall be performed in a manner that does not adversely impact CSX operations or safety; as such, the requirements of this document shall be strictly adhered to, in addition to all other applicable standards associated with the construction. Applicable standards include, but are not limited to, CSX Standards and Special Provisions, CSX Insurance Requirements, CSX Pipeline Occupancy Criteria, as well as the governing local, county, state and federal requirements. It shall be noted that this document and all other CSX standards are subject to change without notice, and future revisions will be made available at the CSX website: www.csx.com.

I. DEFINITIONS

1. Agency – The project sponsor (i.e., State DOT, Local Agencies, Private Developer, etc.)
2. AREMA – American Railway Engineering and Maintenance-of-Way Association – the North American railroad industry standards group. The use of this term shall be in specific reference to the AREMA Manual for Railway Engineering.
3. Construction Submission – The Agency or its representative shall submit six (6) sets of plans, supporting calculations, and detailed means and methods procedures for the specific proposed activity. All plans, specifications, and supporting calculations shall be signed/sealed by a Professional Engineer as defined below.
4. Controlled Demolition – Removal of an existing structure or subcomponents in a manner that positively prevents any debris or material from falling, impacting, or otherwise affecting CSX employees, equipment or property. Provisions shall be made to ensure that there is no impairment of railroad operations or CSX’s ability to access its property at all times.
5. Contractor – The Agency’s representative retained to perform the project work.
6. Engineer – CSX Engineering Representative or a GEC authorized to act on the behalf of CSX.
7. Flagman – A qualified CSX employee with the sole responsibility to direct or restrict movement of trains, at or through a specific location, to provide protection for workers.
8. GEC – General Engineering Consultant who has been authorized to act on the behalf of CSX.
9. Horizontal Clearance – Distance measured perpendicularly from centerline of any track to the nearest obstruction at any elevation between TOR and the maximum vertical clearance of the track.
10. Professional Engineer – An engineer who is licensed in State or Commonwealth in which the project is to occur. All plans, specifications, and supporting calculations shall be prepared by the Licensed Professional Engineer and shall bear his/her seal and signature.
11. Potential to Foul – Work having the possibility of impacting CSX property or operations; defined as one or more of the following:
 - a. Any activity where access onto CSX property is required.

b. Any activity where work is being performed on CSX ROW.

c. Any excavation work adjacent to CSX tracks or facilities, within the Theoretical Railroad Live Load Influence Zone, or where the active earth pressure zone extends within the CSX property limits.

d. The use of any equipment where, if tipped and laid flat in any direction (360 degrees) about its center pin, can encroach within twenty five feet (25'-0") of the nearest track centerline. This is based upon the proposed location of the equipment during use, and may be a function of the equipment boom length. Note that hoisting equipment with the potential to foul must satisfy the 150% factor of safety requirement for lifting capacities.

e. Any work where the scatter of debris, or other materials has the potential to encroach within twenty five feet (25'-0") of the nearest track centerline.

f. Any work where significant vibration forces may be induced upon the track structure or existing structures located under, over, or adjacent to the track structure.

g. Any other work which poses the potential to disrupt rail operations, threaten the safety of railroad employees, or otherwise negatively impact railroad property, as determined by CSX.

12. ROW – Right of Way; Refers to CSX Right-of-Way as well as all CSX property and facilities. This includes all aerial space within the property limits, and any underground facilities.

13. Submission Review Period - a minimum of thirty (30) days in advance of start of work. Up to thirty (30) days will be required for the initial review response. Up to an additional thirty (30) days may be required to review any/all subsequent submissions or resubmission.

14. Theoretical Railroad Live Load Influence Zone – A 1 horizontal to 1 vertical theoretical slope line starting at bottom corner of tie.

15. TOR – Top of Rail. This is the base point for clearance measurements. It refers to the crown (top) of the steel rail; the point where train wheels bear on the steel rails.

16. Track Structure – All load bearing elements which support the train. This includes, but is not limited to, the rail, ties, appurtenances, ballast, sub-ballast, embankment, retaining walls, and bridge structures.

17. Vertical Clearance – Distance measured from TOR to the lowest obstruction within six feet (6'-0") of the track centerline, in either direction.

II. GENERAL SUBMISSION REQUIREMENTS

A. A construction work plan is required to be submitted by the Agency or its Contractor, for review and acceptance, prior to accessing or performing any work with Potential to Foul.

B. The Agency or its representative shall submit six (6) sets of plans, specifications, supporting calculations, and detailed means and methods procedures for the specific proposed work activity.

C. Construction submissions shall include all information relevant to the work activity, and shall clearly and concisely explain the nature of the work, how it is being performed, and what measures are being taken to ensure that railroad property and operations are continuously maintained.

D. All construction plans shall include a map of the work site, depicting the CSX tracks, the CSX right of way, proposed means of access, proposed locations for equipment and material staging (dimensioned from nearest track centerline), as well as all other relevant project information. An elevation drawing may also be necessary in order to depict clearances or other components of the work.

E. Please note that CSX will not provide pricing to individual contractors involved in bidding projects. Bidding contractors shall request information from the agency and not CSX.

F. The Contractor shall install a geotextile fabric ballast protection system to prevent construction or demolition debris and fines from fouling ballast. The geotextile ballast protection system shall be installed and maintained by the Contractor to the satisfaction of the Engineer.

G. The Engineer shall be kept aware of the construction schedule. The Contractor shall provide timely communication to the Engineer when scheduling the work such that the Engineer may be present during the work. The Contractor's schedule shall not dictate the work plan review schedule, and flagging shall not be scheduled prior to receipt of an accepted work plan.

H. At any time during construction activities, the Engineer may require revisions to the previously approved procedures to address weather, site conditions or other circumstances that may create a potential hazard to rail operations or CSX facilities. Such revisions may require immediate interruption or termination of ongoing activities until such time the issue is resolved to the Engineer's satisfaction. CSX and its GEC shall not be responsible for any additional costs or time claims associated with such revisions.

I. Blasting will not be permitted to demolish a structure over or within CSX's right-of-way. When blasting off of CSX property but with Potential to Foul, vibration monitoring, track settlement surveying, and/or other protective measures may be required as determined by the Engineer.

J. Blasting is not permitted adjacent to CSX right-of-way without written approval from the Chief Engineer, CSX.

K. Mechanical and chemical means of rock removal must be explored before blasting is considered. If written permission for the use of explosives is granted, the Agency or Contractor must submit a work plan satisfying the following requirements:

1. Blasting shall be done with light charges under the direct supervision of a responsible officer or employee of the Agency or Contractor.

2. Electronic detonating fuses shall not be used because of the possibility of premature explosions resulting from operation of two-way train radios.

3. No blasting shall be done without the presence of an authorized representative of CSX. Advance notice to the Engineer is required to arrange for the presence of an authorized CSX representative and any flagging that CSX may require.

4. Agency or Contractor must have at the project site adequate equipment, labor and materials, and allow sufficient time, to clean up debris resulting from the blasting and correct any misalignment of tracks or other damage to CSX property resulting from the blasting. Any corrective measures required must be performed as directed by the Engineer at the Agency's or Contractor's expense without any delay to trains. If Agency's or Contractor's actions result in the delay of any trains including passenger trains, the Agency or Contractor shall bear the entire cost thereof.

5. The Agency or Contractor may not store explosives on CSX property.

6. At any time during blasting activities, the Engineer may require revisions to the previously approved procedures to address weather, site conditions or other circumstances that may create a potential hazard to rail operations or CSX facilities. Such revisions may require immediate interruption or termination of ongoing activities until such time the issue is resolved to the Engineer's satisfaction. CSX and its GEC shall not be responsible for any additional costs or time claims associated with such revisions.

III. HOISTING OPERATIONS

A. All proposed hoisting operations with Potential to Foul shall be submitted in accordance with the following:

1. A plan view drawing shall depict the work site, the CSX track(s), the proposed location(s) of the lifting equipment, as well as the proposed locations for picking, any intermediate staging, and setting the load(s). All locations shall be dimensioned from centerline of the nearest track. Crane locations shall also be dimensioned from a stationary point at the work site for field confirmation.

2. Computations showing the anticipated weight of all picks. Computations shall be made based upon the field-verified plans of the existing structure. Pick weights shall account for the weight of concrete rubble or other materials attached to the component being removed; this includes the weight of subsequent rigging devices/components. Rigging components shall be sized for the subsequent pick weight.

3. All lifting equipment, rigging devices, and other load bearing elements shall have a rated (safe lifting) capacity that is greater than or equal to 150% of the load it is carrying, as a factor of safety. Supporting calculations shall be furnished to verify the minimum capacity requirement is maintained for the duration of the hoisting operation.

4. Dynamic hoisting operations are prohibited when carrying a load with the Potential to Foul. Cranes or other lifting equipment shall remain stationary during lifting. (i.e., no moving picks).

5. For lifting equipment, the manufacturer's capacity charts, including crane, counterweight, maximum boom angle, and boom nomenclature is to be submitted.

6. A schematic rigging diagram must be provided to clearly call out each rigging component from crane hook to the material being hoisted. Copies of catalog or information sheets shall be provided to verify rigging weights and capacities.

7. For built-up rigging devices, the contractor shall submit the following:

- i. Details of the device, calling out material types, sizes, connections and other properties.
- ii. Load test certification documents and/or design computations bearing the seal and signature of a Professional Engineer. Load test shall be performed in the configuration of its intended use as part of the subject demolition procedure.

iii. Copies of the latest inspection reports of the rigging device. The device shall be inspected within one (1) calendar year of the proposed date for use.

8. A detail shall be provided showing the crane outrigger setup, including dimensions from adjacent slopes or facilities. The detail shall indicate requirements for bearing surface preparation, including material requirements and compaction efforts. As a minimum, outriggers and/or tracks shall bear on mats, positioned on level material with adequate bearing capacity.

9. A complete written narrative that describes the sequence of events, indicating the order of lifts and any repositioning or re-hitching of the crane(s).

IV. DEMOLITION PROCEDURE

A. The Agency or its Contractor shall submit a detailed procedure for a controlled demolition of any structure on, over, or adjacent to the ROW. The controlled demolition procedure must be approved by the Engineer prior to beginning work on the project.

B. Existing Condition of structure being demolished:

1. The Contractor shall submit as-built plans for the structure(s) being demolished

2. If as-built plans are unavailable, the Contractor shall perform an investigation of the structure, including any foundations, substructures, etc. The field measurements are to be made under the supervision of the Professional Engineer submitting the demolition procedure. Findings shall be submitted as part of the demolition means and methods submittal for review by the Engineer.

3. Any proposed method for temporary stabilization of the structure during the demolition shall be based on the existing plans or investigative findings, and submitted as part of the demolition means and methods for review by the Engineer.

C. Demolition work plans shall include a schematic plan depicting the proposed locations of the following, at various stages of the demolition:

1. All cranes and equipment, calling out the operating radii.

2. All proposed access and staging locations with all dimensions referenced from the center line of the nearest track

3. Proposed locations for stockpiling material or locations for truck loading

4. The location, with relevant dimensions, of all tracks, other railroad facilities; wires, poles, adjacent structures, or buried utilities that could be affected, showing that the proposed lifts are clear of these obstructions.

5. Note that no crane or equipment may be set on the CSX rails or track structure and no material may be dropped on CSX property.

D. Demolition submittal shall also include the following information:

1. All hoisting details, as dictated by Section III of this document.
2. A time schedule for each of the various stages must be shown as well as a schedule for the entire lifting procedure. The proposed time frames for all critical subtasks (i.e., torch/saw cutting various portions of the superstructure or substructure, dismantling splices, installing temporary bracing, etc.) shall be furnished so that the potential impact(s) to CSX operations may be assessed and eliminated or minimized.
3. The names and experience of the key Contractor personnel involved in the operation shall be included in the Contractor's means and methods submission.
4. Design and supporting calculations shall be prepared, signed, and sealed by the Professional Engineer for items including the temporary support of components or intermediate stages shall be submitted for review. A guardrail will be required to be installed in a track in the proximity of temporary bents or shoring towers, when located within twelve feet (12'-0") from the centerline of the track. The guardrail will be installed by CSX forces, at the expense of the Agency or its contractor.

E. Girders or girder systems shall be stable at all times during demolition. Temporary bracing shall be provided at the piers, abutments, or other locations to resist overturning and/or buckling of the member(s). The agency shall submit a design and details of the proposed temporary bracing system, for review by the Engineer. Lateral wind forces for the temporary conditions shall be considered in accordance with AREMA, Chapter 8, Section 28.6.2. The minimum lateral wind pressure shall be fifteen pounds per square foot (15 psf).

F. Existing, obsolete, bridge piers shall be removed to a minimum of three feet (3'-0") below the finished grade, final ditch line invert, or as directed by the Engineer.

G. A minimum quantity of twenty five (25) tons of CSX approved granite track ballast may be required to be furnished and stockpiled on site by the Contractor, or as directed by the Engineer.

H. The use of acetylene gas is prohibited for use on or over CSX property. Torch cutting shall be performed utilizing other materials such as propane.

I. CSX's tracks, signals, structures, and other facilities shall be protected from damage during demolition of existing structure or replacement of deck slab.

J. Demolition Debris Shield

1. On-track or ground-level debris shields (such as crane mats) are prohibited for use by CSX.
2. Demolition Debris Shield shall be installed prior to the demolition of the bridge deck or other relevant portions of the structure. The demolition debris shield shall be erected from the underside of the bridge over the track area to catch all falling debris. The debris shield shall not be the primary means of debris containment.
 - i. The demolition debris shield design and supporting calculations, all signed/sealed by a Professional Engineer, shall be submitted for review and acceptance.
 - ii. The demolition debris shield shall have a minimum design load of 50 pounds per square foot (50 psf) plus the weight of the equipment, debris, personnel, and all other loads.

iii. The Contractor shall verify the maximum particle size and quantity of the demolition debris generated during the procedure does not exceed the shield design loads. Shield design shall account for loads induced by particle impact; however the demolition procedure shall be such that impact forces are minimized. The debris shield shall not be the primary means of debris containment.

iv. The Contractor shall include installation/removal means and methods for the demolition debris shield as part of the proposed Controlled Demolition procedure submission.

v. The demolition debris shield shall provide twenty three feet (23'-0") minimum vertical clearance, or maintain the existing vertical clearance if the existing clearance is less than twenty three feet (23'-0").

vi. Horizontal clearance to the centerline of the track should not be reduced unless approved by the Engineer.

vii. The Contractor shall clean the demolition debris shield daily or more frequently as dictated either by the approved design parameters or as directed by the Engineer.

K. Vertical Demolition Debris Shield

1. This type of shield may be required for substructure removals in close proximity to CSX track and other facilities, as determined by the Engineer.
2. The Agency or its Contractor shall submit detailed plans with detailed calculations, prepared, signed, and sealed by a Professional Engineer, of the protection shield.

V. ERECTION PROCEDURE

A. The Agency or its Contractor shall submit a detailed procedure for erection of a structure with Potential to Foul. The erection procedure must be approved by the Engineer prior to beginning work on the project.

B. Erection work plans shall include a schematic plan depicting the following, at all stages of the construction:

1. All proposed locations of all cranes and equipment, calling out the operating radii.
2. All proposed access and staging locations with all dimensions referenced from the center line of the nearest track.
3. All proposed locations for stockpiling material or locations for truck loading.
4. The location, with relevant dimensions, of all tracks, other railroad facilities; wires, poles, adjacent structures, or buried utilities that could be affected, showing that the proposed lifts are clear of these obstructions.

C. No crane or equipment may be set on the CSX rails or track structure and no material may be dropped on CSX property.

D. For erection of a structure over the tracks, the following information shall be submitted for review and acceptance by the Engineer, at least thirty (30) days prior to erection:

1. As-built beam seat elevations – field surveyed upon completion of pier/abutment construction.
2. Current Top of Rail (TOR) elevations – field measured at the time of as-built elevation collection.
3. Computations verifying the anticipated minimum vertical clearance in the final condition which accounts for all deflection and camber, based upon the current TOR and as-built beam seat elevations. The anticipated minimum

vertical clearance shall be greater than or equal to that which is indicated by the approved plans. Vertical clearance (see definitions) is measured from TOR to the lowest point on the overhead structure at any point within six feet (6'-0") from centerline of the track. Calculations shall be signed and sealed by a Professional Engineer.

E. Girders or girder systems shall be stable at all times during erection. No crane may unhook prior to stabilizing the beam or girder.

1. Lateral wind forces for the temporary conditions shall be considered in accordance with AREMA, Chapter 8, Section 28.6.2. The minimum lateral wind pressure shall be fifteen pounds per square foot (15 psf).
2. Temporary bracing shall be provided at the piers, abutments, or other locations to resist overturning and/or buckling of the member(s). The agency shall submit a design and details of the proposed temporary bracing system, for review by the Engineer.
3. Temporary bracing shall not be removed until sufficient lateral bracing or diaphragm members have been installed to establish a stable condition. Supporting calculations, furnished by the Professional Engineer, shall confirm the stable condition.

F. Erection procedure submissions shall also include the following information:

1. All hoisting details, as dictated by Section III of this document.
2. A time schedule for each of the various stages must be shown as well as a schedule for the entire lifting procedure. The proposed time frames for all critical subtasks (i.e., performing aerial splices, installing temporary bracing, installation of diaphragm members, etc.) shall be furnished so that the potential impact(s) to CSX operations may be assessed and eliminated or minimized.
3. The names and experience of the key Contractor personnel involved in the operation shall be included in the Contractor's means and methods submission.
4. A guardrail will be required to be installed in a track in the proximity of temporary bents or shoring towers, when located within twelve feet (12'-0") from the centerline of the track. The guardrail will be installed by CSX forces, at the expense of the Agency or its Contractor.
5. Design and supporting calculations prepared by the Professional Engineer for items including the temporary support of components or intermediate stages shall be submitted for review.

VI. TEMPORARY EXCAVATION AND SHORING

A. The Agency or its Contractor shall submit a detailed design and procedure for the installation of a sheeting/shoring system adjacent to the tracks. Shoring protection shall be provided when excavating with Potential to Foul, or as otherwise determined by CSX. Shoring shall be provided in accordance with the AREMA, except as noted below.

B. Shoring may not be required if all of the following conditions are satisfied:

1. The excavation does not encroach within the Theoretical Live Load Influence Zone. Please refer to Figure 1.
2. The track structure is situated on level ground, or in a cut section, and on stable soil.
3. The excavation does not adversely impact the stability of a CSX facility (i.e., signal bungalow, drainage facility, undergrade bridge, building, etc), or the stability of any structure on, over, or adjacent to CSX property with potential to foul.
4. Shoring is not required by any governing federal, state, local or other construction code.

C. Shoring is required when excavating the toe of an embankment. Excavation of any embankment which supports an active CSX track structure without shoring will not be permitted.

D. Trench boxes are not an acceptable means of shoring. Trench boxes are prohibited for use on CSX property or within the Theoretical Railroad Live Load Influence Zone.

E. Shoring shall be a cofferdam-type, which completely encloses the excavation. However, where justified by site or work conditions, partial cofferdams with open sides away from the track may be permissible, as determined by the Engineer.

F. Cofferdams shall be constructed using interlocking steel sheet piles, or when approved by the Engineer, steel soldier piles with timber lagging. Wales and struts shall be included when dictated by the design.

G. The use of tiebacks can be permissible for temporary shoring systems, when conditions warrant. Tiebacks shall have a minimum clear cover of 6'-0", measured from the bottom of the rail. Upon completion of the work, tiebacks shall be grouted, cut off, and remain in place.

H. All shoring systems on, or adjacent to CSX right-of-way, shall be equipped with railings or other fall protection, compliant with the governing federal, state or local requirements. Area around pits shall be graded to eliminate all potential tripping hazards.

I. Interlocking steel sheet piles shall be used for shoring systems qualifying one or more of the following conditions:

1. Within 18'-0" of the nearest track centerline
2. Within the live load influence zone
3. Within slopes supporting the track structure
4. As otherwise deemed necessary by the Engineer.

J. Sheet piles qualifying for one or more of the requirements listed in Section VI.I (above) of this document shall not be removed. Sheet piles shall be left in place and cut off a minimum of 3'-0" below the finished grade, the ditch line invert, or as otherwise directed by the Engineer. The ground shall be backfilled and compacted immediately after sheet pile is cut off.

K. The following design considerations shall be considered when preparing the shoring design package:

1. Shoring shall be designed to resist a vertical live load surcharge of 1,880 lbs. per square foot, in addition to active earth pressure. The surcharge shall be assumed to act on a continuous strip, eight feet six inches (8'-6") wide. Lateral pressures due to surcharge shall be computed using the strip load formula shown in AREMA Manual for Railway Engineering, Chapter 8, Part 20.
2. Allowable stresses in materials shall be in accordance with AREMA Chapter 7, 8, and 15.3.
3. A minimum horizontal clearance of ten feet (10'-0") from centerline of the track to face of nearest point of shoring shall be maintained, provided a twelve feet (12'-0") roadbed is maintained with a temporary walkway and handrail system.

4. For temporary shoring systems with Potential to Foul, piles shall be plumb under full dead load. Maximum deflection at the top of wall, under full live load, shall be as follows:

- i. One-half (1/2) inch for walls within twelve feet (12'-0") of track centerline (Measured from centerline of the nearest track to the nearest point of the supporting structure).
- ii. One (1) inch for walls located greater than twelve feet (12'-0") from track centerline

L. Shoring work plans shall be submitted in accordance with Section II of this document, as well as the following additional requirements:

- 1. The work plan shall include detailed drawings of the shoring systems calling out the sizes of all structural members, details of all connections. Both plan and elevation drawings shall be provided, calling out dimensions from the face of shoring relative to the nearest track centerline. The elevation drawing shall also show the height of shoring, and track elevation in relation to bottom of excavation.
- 2. Full design calculations for the shoring system shall be furnished.
- 3. A procedure for cutting off the sheet pile, backfilling and restoring the embankment.

VII. TRACK MONITORING

A. When work being performed has the potential to disrupt the track structure, a work plan must be submitted detailing a track monitoring program which will serve to monitor and detect both horizontal and vertical movement of the CSX track and roadbed.

B. The program shall specify the survey locations, the distance between the location points, and frequency of monitoring before, during, and after construction. CSX reserves to the right to modify the survey locations and monitoring frequency as necessary during the project.

C. The survey data shall be collected in accordance with the approved frequency and immediately furnished to the Engineer for analysis.

D. If any movement has occurred as determined by the Engineer, CSX will be immediately notified. CSX, at its sole discretion, shall have the right to immediately require all contractor operations to be ceased, have the excavated area immediately backfilled and/or determine what corrective action is required. Any corrective action required by CSX or performed by CSX including the monitoring of corrective action of the contractor will be at project expense.

FIGURE 1: Theoretical Live Load Influence Zone

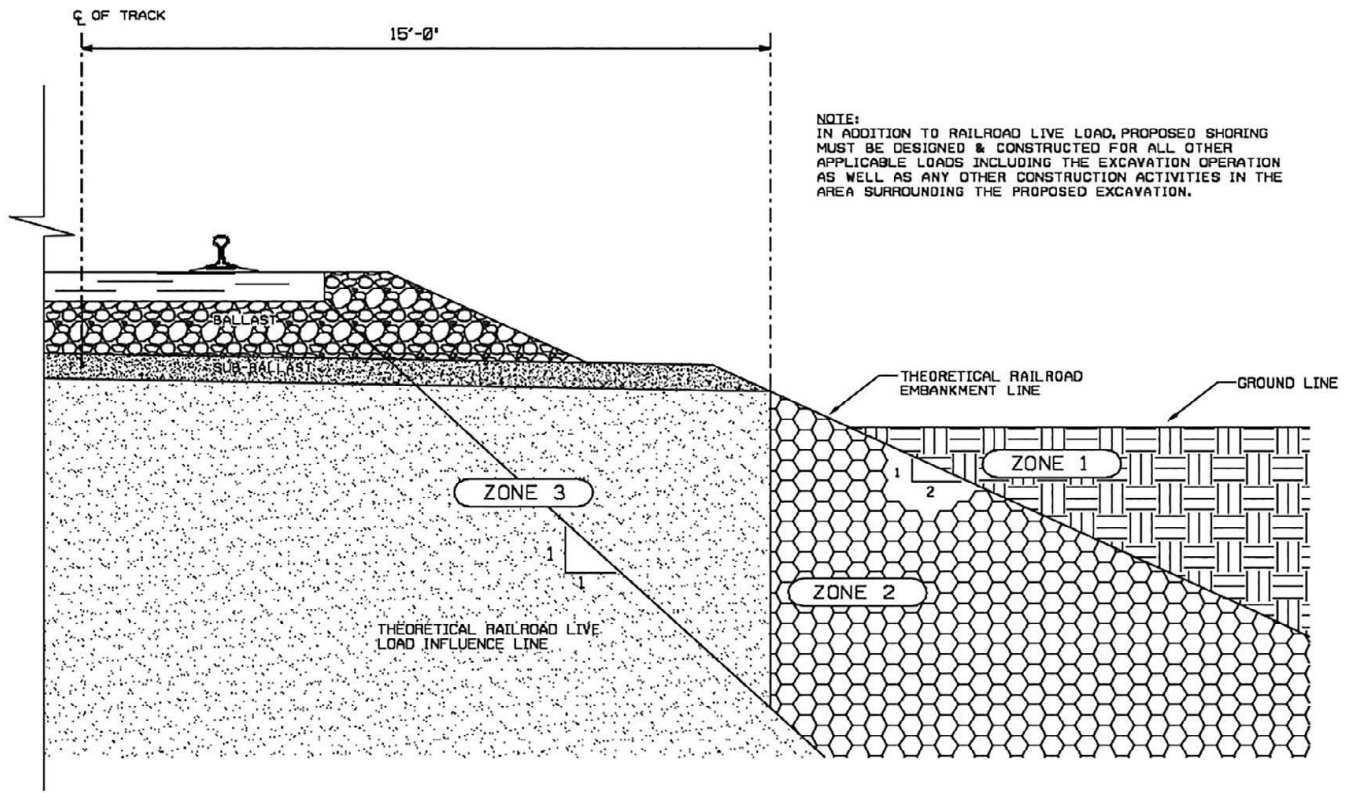

NORMAL REQUIREMENTS FOR SHORING ADJACENT TO TRACK



ZONE 1 - EXCAVATIONS ABOVE AND OUTSIDE OF THE THEORETICAL RAILROAD EMBANKMENT LINE - DO NOT NORMALLY REQUIRE SHORING TO PROTECT RAILROAD ROADBED, SHORING MAY BE REQUIRED FOR OTHER REASONS.



ZONE 2 - EXCAVATIONS WHOSE BOTTOMS EXTEND INTO ZONE 2 REQUIRE SHORING, BUT THE SHORING MAY NORMALLY BE PULLED AFTER THE EXCAVATION HAS BEEN BACKFILLED.



ZONE 3 - EXCAVATIONS WHOSE BOTTOMS EXTEND INTO ZONE 3 WILL NORMALLY REQUIRE THE SHORING TO BE LEFT IN PLACE AND CUT-OFF 3' BELOW BASE OF RAIL. SHORING MUST BE DESIGNED FOR COOPER E80 LIVE LOAD

CONSTRUCTION REQUIREMENTS

When performing work on, over, or adjacent to CSX Transportation (“CSXT”) right-of-way or operations, the North Carolina Department of Transportation (“NCDOT”) selected contractor (“Contractor”) must abide by the current CSXT Special Provisions, CSXT Construction Submission Criteria, and the following additional requirements.

1. All construction related correspondence shall be directed electronically to Moffatt and Nichol, acting as the Construction Monitoring Representative (“CMR”) on behalf of CSXT, with the following contact and address:

Jason Field
4700 Falls of Neuse
Suite 300
Raleigh, NC 27609
JField@moffattnichol.com
Telephone: (919) 645-0639

All email correspondence with CSXT/ Moffatt and Nichol should use the subject line “(Subject of Transmission) – NC1127 - Maxton, NC – Bridge Preservation – HI-0017 - Carolinas Division - Wilmington Subdivision”.

Failure to use this subject line may result in delayed project handling.

2. Prior to construction, NCDOT or Contractor shall provide an electronic copy of the entire and complete set of Final Approved-For-Construction Plans for the subject project to the CMR. Any subsequent revisions or addendums to the Final Approved-For-Construction Plans shall also be provided.
3. Prior to any construction activities on, over, under or adjacent to CSXT, the Contractor shall have a pre-construction meeting with CSXT’s designated representative and the CMR to discuss potential On-Track Safety issues during project construction activities.
4. Construction procedures for all work in the vicinity of CSXT property, that has the potential of affecting CSXT property or operations, shall be submitted electronically to the CMR. Prior to the work being performed, the Contractor shall obtain written acceptance of the submitted construction procedures from CSXT or their representative before proceeding with construction.

Up to thirty (30) days will be required to review all construction submissions. Up to an additional thirty (30) days will be required to review any subsequent submissions returned not approved with requests for additional information. Work will not be permitted to commence until the Contractor has provided CSXT with a satisfactory plan for the associated work, detailing how the work will be undertaken without impacting scheduling, performance or safety related issues.

NOTE: All construction work shall be performed in accordance with the construction procedure reviewed and accepted by CSXT or the CMR. Revisions to Contractor submissions may not be field approved. Any deviation(s) from a previously accepted plan including equipment substitutions will require a formal resubmission of the procedure for review and acceptance prior to performing any work.

The Contractor shall submit, as separate submittals, the following construction procedures and documents, and any additional construction procedures determined to be necessary by the CSXT or the CMR.

- a. Means and Methods – The Contractor shall develop separate detailed submissions for each work items presenting the potential to impact CSXT property or operations. The work items requiring submissions should be coordinated with the CMR prior to their development and submission. Each submission shall:
 - i. Indicate the progression of work with specific times when tasks will be performed during the project.
 - ii. Provide a listing of the anticipated equipment to be used, a marked-up plan with relevant dimensions detailing the location of all equipment to be used, and a contingency plan of action should a primary piece of equipment malfunction.
 - iii. Include a detailed narrative discussing the project level coordination of specific work operations and project safety issues between the NCDOT, Contractor, CSXT, and the CMR.
 - iv. If determined by CSXT or the CMR to be necessary, include a walkthrough at which time CSXT and/or the CMR will be present.

Anticipated means and methods submissions include, but are not limited to, crane and equipment operations, demolition plans, erection plans and temporary works.

- b. Demolition Procedures, Demolition Debris Shields, and Erection Procedures are required to be submitted to CSXT or the CMR in accordance with the CSXT Construction Submission Criteria.
- c. Temporary Work Platform and Containment System – Removed paint and debris may not be deposited on the CSXT right-of-way at any time during cleaning and painting operations. Vacuum type systems for paint removal operations to prevent paint and debris deposits are required in lieu of a containment system over the track(s). The Contractor shall submit a containment system for work over CSXT for acceptance by the railroad if the following CSXT horizontal and vertical clearance standards can be maintained. Any temporary containment system shall not encroach horizontally within eighteen feet (18'-0") measured perpendicularly from the centerline of the nearest track. Any containment system must also maintain the existing vertical clearance over all tracks or a minimum of twenty-three feet (23'-0") measured from top of high rail to the lowest point of structure in the clearance area which extends six feet (6'-0") to both sides from centerline of track. The temporary work platform and containment system shall include written installation and removal procedures along with plans and associated details of the proposed system. Engineering calculations that support the proposed temporary work platform and containment system are to be signed and sealed by a Professional Engineer licensed in the state in which the work is being performed. The design of the system shall also be in accordance with OSHA and fully comply with all federal, state, and local environmental laws, regulations, statutes and ordinances at all times.
- d. Construction Schedule – Within 30 days of the pre-construction meeting, Contractor shall submit a detailed construction schedule for the duration of the project clearly indicating the time periods while working on and around CSXT right-of-way. As the work progresses, this schedule shall be updated and resubmitted as necessary to reflect changes in work sequence, duration and method, etc.
- e. Emergency Action Plan – Submit an emergency action plan indicating the location of the site, contact numbers, access to the site, instructions for emergency response and location of the nearest hospitals (including map and directions from project site). This plan should cover all items required in the event of an emergency at the site including fire suppression. Coordinate the Emergency Action Plan with the safety related discussion of the Means and Methods submission discussed above. The plan should also include a method to provide this information to each project worker for each day on site.

- f. COVID Action Plan – Submit an action plan indicating how operations will be handled in the event a team member(s) is infected with COVID-19. This plan shall include details regarding COVID-19 handling, reporting and quarantining guidelines.
5. Ballast Protection – A ballast protection system may be required at the sole discretion of CSXT depending on the contractor’s proposed methods to perform the work. The system shall use non-woven geotextile filter fabric and be placed over the entire track structure to keep the ballast clean. The ballast protection system shall extend along the track structure a minimum of twenty-five feet (25’-0”) beyond the limits of work being performed, or greater as determined by CSXT. Additional extents of ballast protection may be required, as determined by the CMR, to ensure protection of the CSXT ballast. The filter fabric shall be sufficiently overlapped and securely fastened to avoid a tripping hazard. The geotextile ballast protection shall be kept clean and maintained during the life of the project to prevent all contaminants from entering the ballast.
6. Submit all necessary insurance information in accordance with the current CSXT Insurance Requirements for approval. The Certificate of Insurance shall be prepared in keeping with the sample included in Exhibit A of this document. The complete original policies should be submitted to insurancedocuments@csx.com with a copy to the CMR.

The insurance policies will be required to be in place and approved prior to any work commencing on or that could potentially impact CSXT right-of-way. The NCDOT or Contractor shall maintain the necessary insurance coverage throughout the life of the project. Failure to maintain insurance coverage will result in the stoppage of work at no additional cost to CSXT.

As information for use in obtaining the required CSXT insurance, please note that CSXT operates approximately two (2) total freight trains per day at a maximum authorized speed of ten (10) miles per hour (mph) at the project location.

7. **CSXT Emergency Number:** The CSXT telephone number for emergencies is 800-232-0144. When calling, reference the appropriate CSXT Milepost and Crossing# from the following:
 - 770454 (US 74 Bypass EB over CSXT), Railroad MP SE-274.600, Crossing No. 973585N
 - 770455 (US 74 Bypass WB over CSXT), Railroad MP SE-274.600, Crossing No. 973584G
 - 770456 (US 74 Bypass EB over CSXT), Railroad MP AG-245.940, Crossing No. 938183P
 - 770457 (US 74 Bypass WB over CSXT), Railroad MP AG-245.920, Crossing No. 938182H
8. No stormwater or construction generated water may discharge onto the CSXT right-of-way at any time during construction.
9. The Contractor must not use CSXT right-of-way for storage of materials or equipment during construction. The CSXT right-of-way must remain clear for railroad use at all times. Equipment may not be positioned to block the railroad access road, track area, or any part of the CSXT right-of-way without prior CSXT approval.
10. No temporary or permanent reductions to the existing horizontal and vertical clearances shall be permitted without prior CSXT approval. All Contractor work shall be performed in strict compliance with CSXT clearance requirements.
11. The Contractor will be required to abide by the provisions of the NCDOT/CSXT Construction Agreement. Periodically, throughout the project duration, the Contractor will be required to meet, discuss, and, if necessary, take immediate action at the discretion of CSXT personnel and/or the CMR to comply with provisions of that agreement and these specifications.
12. The Contractor shall not remove any existing CSXT owned material (including, but not limited to, soil, stone, bridge and retaining wall elements, communications and signals device components, and

drainage facilities) from CSXT right-of-way without prior authorization from CSXT. In the event that such material cannot be relocated within CSXT's right-of-way in a manner satisfactory to CSXT, the material shall be properly tested by CSXT for contamination and disposed of in accordance with the CSX disposal policy. All costs associated with testing, coordination and/or disposal will be charged to the project. Initial environmental related requests should be made with the CMR at least thirty (30) days in advance.

13. This project will require use of CSXT Flagmen or Third-Party Field Construction Inspectors (FCI) to protect train operations from project activity in the area of the tracks. While CSXT cannot guarantee the availability of Flagmen or FCIs at all requested times, every accommodation will be extended to the Contractor when forces are available. To request flagging, the Contractor shall submit weekly Flagging Request Forms to RRFlagging@Moffattnichol.com by 5 PM on Monday for work scheduled for the following week. Incomplete or late submissions will not be considered.
14. All crane and equipment operations that could potentially impact CSXT right-of-way must be coordinated with the CSXT Flagman.
15. The Contractor or the NCDOT shall be responsible to have painted on the structure the DOT Number assigned to the grade separation. This number shall be affixed at a location on either side of the CSXT tracks or property and in a manner such that it can be readily discerned and visible from track level. The font size of the DOT # numbers and letter should be at least four inches (4") tall and shall be black on a light-colored background or white on a dark-colored background of the grade separation component.
16. Prior to entering CSXT right-of-way or performing any work that could potentially impact CSXT operations, the Contractor must enter into a fully executed Temporary Right of Entry Agreement with CSXT.
17. Contractor access will be limited to the immediate project area only. The CSXT right-of-way may not be used for contractor access to the project site and no temporary at-grade crossings will be allowed.
18. NCDOT and Contractor agree to fully comply with all federal, state, and local environmental laws, regulations, statutes, and ordinances at all times.
19. Temporary reductions in vertical and horizontal clearances are not permitted.

Exhibit A

CERTIFICATE OF LIABILITY INSURANCE

Date: MM/DD/YY

THIS CERTIFICATE IS ISSUED AS A MATTER OF INFORMATION ONLY AND CONFERS NO RIGHTS UPON THE CERTIFICATE HOLDER. THIS CERTIFICATE DOES NOT AFFIRMATIVELY OR NEGATIVELY AMEND, EXTEND OR ALTER THE COVERAGE AFFORDED BY THE POLICIES BELOW. THIS CERTIFICATE OF INSURANCE DOES NOT CONSTITUTE A CONTRACT BETWEEN THE ISSUING INSURER(S), AUTHORIZED REPRESENTATIVE OR PRODUCER, AND THE CERTIFICATE HOLDER.

IMPORTANT: If the certificate holder is an ADDITIONAL INSURED, the policy(ies) must be endorsed. If SUBROGATION IS WAIVED, subject to the terms and conditions of the policy, certain policies may require an endorsement. A statement on this certificate does not confer rights to the certificate holder in lieu of such endorsement(s).

PRODUCER
 Phone:
 Fax:

CONTACT NAME:
 PHONE (A/C, No, Ext):
 E-MAIL:
 ADDRESS:
 PRODUCER CUSTOMER ID #:

Name & Address of Producer

INSURER(S) AFFORDING COVERAGE NAIC #
 INSURER A: AM Best Rating A-, Or Better provide
 INSURER B: AM Best Rating A-, Or Better provide
 INSURER C: AM Best Rating A-, Or Better provide
 INSURER D: AM Best Rating A-, Or Better provide

INSURED
 Name & Address of Insured

COVERAGES CERTIFICATE NUMBER REVISION NUMBER
 THIS IS TO CERTIFY THAT THE POLICIES OF INSURANCE LISTED BELOW HAVE BEEN ISSUED TO THE INSURED NAMED ABOVE FOR THE POLICY PERIOD INDICATED. NOTWITHSTANDING ANY REQUIREMENT, TERM OR CONDITION OF ANY CONTRACT OR OTHER DOCUMENT WITH RESPECT TO WHICH THIS CERTIFICATE MAY BE ISSUED OR MAY PERTAIN, THE INSURANCE AFFORDED BY THE POLICIES DESCRIBED HEREIN IS SUBJECT TO ALL THE TERMS, FEES, LIMITS AND CONDITIONS OF SUCH POLICIES. LIMITS SHOWN MAY HAVE BEEN REDUCED BY PAID CLAIMS.

INSR LTR	TYPE OF INSURANCE	ADDL. SUBR. INSR. WVD	POLICY NUMBER	POLICY EFF. DATE (MM/DD/YY)	POLICY EXP. DATE (MM/DD/YYYY)	LIMITS
A	GENERAL LIABILITY					
	COMMERCIAL GENERAL LIABILITY					EACH OCCURRENCE \$5,000,000
	CLAIMS MADE <input checked="" type="checkbox"/> OCCUR <input type="checkbox"/>					DAMAGE TO RENTED PREMISES (Ea occurrence)
	GENERAL AGG. LIABILITY APPLIES PER POLICY PROJECT <input checked="" type="checkbox"/> LOC <input type="checkbox"/>					MED EXP (Any one person)
	AUTOMOBILE LIABILITY					PERSONAL & AOV INJURY
	<input checked="" type="checkbox"/> ANY AUTO					GENERAL AGGREGATE
	<input checked="" type="checkbox"/> ALL OWNED AUTOS					PRODUCTS-COMP/OP AGG
	<input checked="" type="checkbox"/> SCHEDULED AUTOS					COMBINED SINGLE LIMIT \$1,000,000
	<input checked="" type="checkbox"/> HIRED AUTOS					(Ea accident)
	<input checked="" type="checkbox"/> NON-OWNED AUTOS					BODILY INJURY (Per person)
	CA 20 70					BODILY INJURY (Per accident)
						PROPERTY DAMAGE (Per accident)
	UMBRELLA FORM <input checked="" type="checkbox"/> OCCUR <input type="checkbox"/>					EACH OCCURRENCE
	EXCESS LIAB. CLAIMS MADE					AGGREGATE
	DEDUCTIBLE					
	RETENTION					
D	WORKERS COMPENSATION AND EMPLOYERS LIABILITY					
	ANY PROPRIETOR/PARTNER/EXECUTIVE OFFICER/MEMBER EXCLUDED? <input checked="" type="checkbox"/>					<input checked="" type="checkbox"/> WC STATUTORY LIMITS OTHER
	(Mandatory in NJ)					E.L. EACH ACCIDENT \$1,000,000
	2 yrs. disclosure					DISEASE - EA EMPLOYEE \$1,000,000
	DESCRIPTION OF OPERATIONS below					E.L. DISEASE - POLICY LIMIT \$1,000,000
	Railroad Protective Coverage					Each Occurrence \$5,000,000

DESCRIPTION OF OPERATIONS / LOCATIONS / VEHICLES
 CSX Transportation is listed as an Additional Insured.

CERTIFICATE HOLDER
 CSX Transportation
 Insurance Compliance
 500 Water Street, Speed Code J-907
 Jacksonville, FL 32202
 RenewalCOI@CSX.com

CANCELLATION
 SHOULD ANY OF THE ABOVE DESCRIBED POLICIES BE CANCELLED BEFORE THE EXPIRATION DATE THEREOF, NOTICE WILL BE DELIVERED IN ACCORDANCE WITH THE POLICY PROVISIONS.

AUTHORIZED REPRESENTATIVE
 Certificate Must be Signed

BP1-90

Maxton, Robeson County, North Carolina
Preservation of Bridges 770454, 770455, 770456, and 770457 on US 74 over CSXT
Carolinas Division, Wilmington Subdivision
CSXT OP# NC1127; State# HI-0017

CSX TRANSPORTATION
Temporary Right of Entry

APPENDIX

CSX TRANSPORTATION

TEMPORARY RIGHT OF ENTRY AGREEMENT

THIS AGREEMENT, made as of _____, 20 ____, by and between CSX TRANSPORTATION, INC., a Virginia corporation, whose mailing address is 500 Water Street, Jacksonville, Florida 32202, hereinafter called "CSX," and (*****), whose mailing address is (*****), (*****), hereinafter called "Licensee," WITNESSETH:

WHEREAS, Licensee has submitted a written application to CSX requesting permission to enter CSX's property located within the (****) Division, (****) Subdivision, at DOT#: (****) MP (****). (**Street**) in (**City**), (**) County, (**State**) (the "Property"), (description of scope of work), beginning (**) feet from the (****) and (**) right of way, (the "Project").

WHEREAS, CSX is willing to grant to Licensee the limited right and permission to enter upon the Property for the limited purpose of performing the Project.

NOW THEREFORE, CSX hereby grants to Licensee the right and permission to enter upon the Property for the purpose of performing said Project, subject to the terms and conditions set forth below:

1. PROJECT: The Project shall be performed at the entire cost and expense of Licensee, in accordance with good and sound engineering practices, to the satisfaction of CSX's Division Engineer or his or her duly authorized representative ("Division Engineer") and in a manner to avoid accidents, damages, unnecessary delays to or interference with train traffic of CSX. Prior to entry, Licensee shall notify the Division Engineer's representative and arrange for flagging protection in accordance to Sections 5 and 6 of this Agreement. Licensee shall not dig in the ballast line or within the tracks loading influence area, or otherwise disturb the track structure. Licensee and Licensee's employees, agents, contractors and other representatives (collectively, "Agents") shall maintain in their possession a copy of this Agreement at all times during their occupation of the Property.

2. INDEMNITY:

2.1 Licensee hereby assumes risk of and agrees to indemnify, defend, protect and save CSX and CSX's Affiliates harmless with respect to any and all attorneys' fees, liability, claims, demands, payments, suits, actions, recoveries, penalties, costs, legal expenses, judgments, settlements, and damages of every nature, degree, and kind (including direct, indirect, consequential, incidental, and punitive damages) for:

2.1.1 Personal injury, including, but not limited to bodily injury to or death of any person or persons whomsoever, including the agents, servants, Affiliates or employees of the parties;

2.1.2 The loss or damage to any property whatsoever, including property owned or in the care, custody or control of the parties hereto or their respective Affiliates;

2.1.3 Any environmental damage and any related remediation brought or recovered against CSX or any of its Affiliates; and

2.1.4 Any and all other losses or damages; arising directly or indirectly from the presence of Licensee or its Agents on or about the Property, whether or not attributable in whole or part to the negligence, gross negligence, or intentional misconduct of CSX or its Affiliates.

2.2 The parties waive any and all right or opportunity to contest the enforceability of this Section and agree that, in the event this Section, or any part of this Section, is found unenforceable by the final, unappealable judgment of a court of competent jurisdiction, this Section shall be construed so as to be enforceable to the maximum extent permitted by applicable law. In the event that such court of competent jurisdiction finds that Florida statutory construction contract indemnity monetary limits apply to this Agreement with respect to Licensee's indemnification of CSX and its Affiliates for liability caused in whole or in part by any act, omission or default by CSX or its Affiliates, the parties hereto agree that such limit shall be equal to the limits (exclusive of deductibles) of the applicable insurance required by Sections 3 and 4 of this Agreement. The parties acknowledge and agree that this monetary limit,

if required, bears a commercially reasonable relationship to this Agreement, in so far as, among other factors, the parties have taken into account the availability and cost of insurance and other risk transference devices, the scope of the Project, the risks associated with the Project, and the compensation and any other benefits exchanged between the parties in connection with this Agreement.

2.2.1 Licensee shall comply with any federal, state, or local laws, statutes, codes, ordinances, rules, and regulations applicable to its presence or performance of any activity on the Property and agrees to indemnify, defend, and hold CSX and its Affiliates harmless with respect to any fines, penalties, liabilities, or other consequences for its failure to so comply.

2.2.2 For the purpose of this Agreement, the term "Affiliates" includes all entities, directly or indirectly owned or controlled by, or under common control of a party or its respective officers, directors, employees and agents, and in the case of CSX, includes CSX Corporation, CSX and their Affiliates and their respective officers, directors, employees and agents.

2.2.3 The provisions of this Section shall survive the termination or expiration of this Agreement.

3. **GENERAL LIABILITY INSURANCE:** Licensee shall procure and maintain, at its expense: (i) statutory Worker's Compensation and Employers Liability Insurance with available limits of not less than \$1,000,000.00, which insurance must contain a waiver of subrogation against CSX and its Affiliates; (ii) Commercial General Liability coverage (inclusive of contractual liability) with available limits of not less than \$5,000,000.00 in combined single limits for bodily injury and property damage and covering the contractual liabilities assumed under this Agreement; (iii) business automobile liability insurance with available limits of not less than \$1,000,000.00 combined single limit for bodily injury and/or property damage per occurrence; and (iv) such other insurance as CSX may reasonably require. Upon request, Licensee shall provide CSX with a copy of Licensee's applicable insurance policies. A policy endorsement naming CSX as an additional insured and specifying such coverage shall be furnished to CSX prior to the execution of this Agreement, and the required coverage will be kept in force until all of Licensee's obligations under this Agreement have been fully discharged and fulfilled, or until Licensee shall have been specifically released by a written instrument signed by an authorized officer of CSX. Licensee shall also provide CSX with a copy of the insurance policies. The insurance policies shall provide that the insurance carrier must give CSX notice at least thirty (30) days in advance of cancellation of coverage, of any change in coverage, or of cancellation of the policy. Notwithstanding any provisions of this Section, the liability assumed by Licensee shall not be limited to the required insurance coverage.

4. **RAILROAD PROTECTIVE LIABILITY INSURANCE:** Licensee agrees to purchase Railroad Protective Liability Insurance in accordance with CSX's requirements (attached as Exhibit A and incorporated into this Agreement) for the benefit of CSX for Licensee's operations under this Agreement. Licensee shall furnish an appropriate Insurance policy (and required endorsements), as the case may be, with the return of this executed Agreement.

5. **PRIOR NOTIFICATION:** Licensee or Licensee's Agents shall notify CSX's Roadmaster at least 10 days prior to requiring entry on the Property and shall abide by the instructions of the Division Engineer, or his or her authorized representative. The Roadmaster, (****), can be contacted at: (*****), to schedule flagging services.

6. **CLEARANCES:** Neither Licensee nor Agents shall perform any Project or place or operate any equipment of Licensee or Agents at a distance closer than fifty (50) feet from the center of any track, without the prior approval of the Division Engineer. The Division Engineer may require protective services or such other services as deemed necessary or appropriate. Equipment shall be moved across CSX's track(s) only at a public crossing unless prior arrangements have been made with the Division Engineer and a Private Crossing Agreement is fully executed and in place. Licensee and Agents shall take all precautions

necessary to avoid interference with or damage to CSX's property and signal and communication facilities during their performance of the Project.

7. PROTECTIVE SERVICES: If protective services, such as flagging protection, are required by CSX, Licensee shall make arrangements with the Roadmaster to furnish such personnel, flagman or watchman, that in the Roadmaster's opinion may be necessary to protect the facilities and traffic of CSX during the performance of the Project. Licensee shall pay for the cost of such services, including all applicable surcharges and additives. These services are estimated to be \$ _____, as supported by the attached estimate.

8. PAYMENT FOR PROTECTIVE SERVICES: Payment shall be made by Licensee in accordance with the following designated option:

() Option 1: Licensee shall make an advance deposit of funds based on an estimate of the cost of protective or other services as determined by CSX. The cost for CSX's services shall then be assessed by CSX against this advance deposit. Upon completion of the Project, any unused funding will be returned to Licensee. Notwithstanding the foregoing, in the event Licensee performs any Project work without permission or without protective services (such as flagging protection) as may be required by CSX, no portion of Licensee's advance deposit will be refunded. If CSX's costs exceed the advance deposit(s), a request will be made to Licensee for additional funds or an invoice will be issued to Licensee for final payment. Licensee shall remit payment to CSX within thirty (30) days of receipt of either a request for additional funds or an invoice.

() Option 2: Licensee shall promptly reimburse CSX for the cost of protective or other services on an as-incurred basis, including all applicable surcharges, upon receipt of bill(s) therefor.

9. ENVIRONMENTAL: This Agreement does not include and expressly excludes the performance of any site investigation activities designed to determine environmental conditions on, about or beneath the Property. Precluded activities include performing soil borings for purposes other than geotechnical investigation, obtaining soil, sediment, groundwater and surface water samples, and conducting field or laboratory analyses of any soil, sediment, groundwater or surface water samples obtained from CSX property to identify chemical composition or environmental condition. If any type of environmental investigation is desired, a separate right of entry agreement issued through CSX's Environmental Department must be secured.

10. CLAIMS: Licensee shall, or shall require Agents, to promptly notify the Division Engineer of any loss, damage, injury or death arising out of or in connection with the Project.

11. REMEDIATION: It is understood and agreed that, upon completion of the Project, the Property shall be left in a condition satisfactory to Division Engineer or his or her duly authorized representative.

12. SAFETY:

12.1 All personnel entering the Property must comply with CSX safety rules and requirements to include, without exception, the wearing of hard hats and approved safety shoes and safety glasses with side shields. Anyone not in compliance with these rules and regulations will be asked to leave the Property.

12.2 Before performing any work authorized by this Agreement, Licensee, at its sole cost and expense, shall obtain all necessary permit(s) (including but not limited to zoning, building, construction, health, safety or environmental matters), letter(s) or certificate(s) of approval. Licensee expressly agrees and warrants that it shall conform and limit its activities to the terms of such permit(s), approval(s) and authorization(s), and shall comply with all applicable ordinances, rules, regulations, requirements and laws of any governmental authority (state, federal or local) having jurisdiction over Licensee's activities, including the location, contact, excavation and protection regulations of the Occupational Safety and Health Act (OSHA) (29 CFR 1926.651(b), et al.), and State "One Call" - "Call Before You Dig" requirements.

13. TERM: This Right-of-Entry Agreement and the permission conferred and the license granted by it does not constitute a grant of permanent easement and shall terminate upon completion of the Project or at midnight, , whichever occurs first, unless extended in writing by CSX. In the event Licensee fails to comply with terms and provisions of this Agreement, Licensee agrees to pay and agrees that CSX shall be entitled to recover costs and expenses incurred by CSX, including legal fees and expenses, to enforce the terms of this Agreement.

14. SEVERABILITY: The parties agree that if any part, term or provision of the Agreement is held to be illegal, unenforceable or in conflict with any applicable federal, state, or local law or regulation, such part, term or provision shall be severable, with the remainder of the Agreement remaining valid and enforceable. If any provision or any part of a provision of the Agreement shall be finally determined to be superseded, invalid, illegal, or otherwise unenforceable pursuant to any applicable law, ordinance, rule or regulation, such determination shall not impair or otherwise affect the validity, legality, or enforceability of the remaining provision or parts of the provision of the Agreement, which shall remain in full force and effect as if the unenforceable provision or part were deleted.

15. ENTIRE AGREEMENT: This Agreement embodies the entire understanding of the parties, may not be waived or modified except in a writing signed by authorized representatives of both parties, and supersedes all prior or contemporaneous written or oral understandings, agreements or negotiations regarding its subject matter.

16. NOTICES: All notices, consents and approvals required or permitted by this agreement shall be in writing and shall be deemed delivered; upon personal delivery, upon the expiration of three (3) business days following mailing by U.S. first class mail, or upon the next business day following mailing by a nationally recognized overnight carrier, to the Licensee at the address above, and to Licensor at the address shown on Page 1, or at such other addresses as either party may designate by delivery of prior notice to the other party .

17. TERMINATION: CSX shall have the right at any time and at its sole discretion to terminate this Agreement upon notice to Licensee.

18. WAIVER: If either party fails to enforce its respective rights under this Agreement, or fails to insist upon the performance of the other party's obligations hereunder, such failure shall not be construed as a permanent waiver of any rights or obligations in this Agreement.

19. GOVERNING LAW; VENUE: This Agreement shall be governed by and construed under the laws of the State of Florida, without regard to the choice of law provisions thereof. Venue for any action arising from, or brought to enforce, this Agreement, shall vest exclusively in the state or federal courts located in Duval County, Florida, and the parties agree to submit to the personal jurisdiction of any state or federal court located in Duval County, Florida.

20. NO ASSIGNMENT: Notwithstanding anything to the contrary contained in this Agreement, Licensee shall not permit Agents to enter the Property without first requiring Agents to agree in writing to comply with all of the terms of this Agreement. Notwithstanding the foregoing, Licensee shall continue to be responsible for insuring that Agents comply with all of the terms and conditions of this Agreement and shall indemnify and hold CSX harmless for any damages described in Section 2 above caused in whole or in part by such subcontractor. Assignment of this Agreement to any party other than Agents in accordance with this Section shall not be permitted except upon the prior written consent of CSX, which consent may be granted or withheld at CSX's sole discretion. This Agreement shall be binding upon the parties and their respective successors and assigns.

IN WITNESS WHEREOF, the parties hereto have caused this Agreement to be executed as of the day and year first above written.

Witness for CSX Transportation:

CSX TRANSPORTATION, INC.

By: _____

Name:

Title:

Witness for: ()

():

By: _____

Print/Type Name:

Print/Type Title:

Who, by the execution hereof, affirms that he/she has the authority to do so and to bind the [*] to the terms and conditions of this Agreement.

ATTACHMENT "A"

INSURANCE REQUIREMENTS

I. Insurance Policies:

Agency and its Designee, if and to the extent that either is performing work on or about CSX's property, shall procure and maintain the following insurance policies:

1. Commercial General Liability coverage at their sole cost and expense with limits of not less than \$5,000,000 in combined single limits for bodily injury and/or property damage per occurrence, and such policies shall name CSX as an additional named insured. The policy shall include endorsement ISO CG 24 17 evidencing that coverage is provided for work within 50 feet of a railroad. If such endorsement is not included, railroad protective liability insurance must be provided as described in item 4 below.
2. Statutory Worker's Compensation and Employers Liability Insurance with limits of not less than \$1,000,000, which insurance must contain a waiver of subrogation against CSX and its affiliates (if permitted by state law).
3. Commercial automobile liability insurance with limits of not less than \$1,000,000 combined single limit for bodily injury and/or property damage per occurrence, and such policies shall name CSX as an additional named insured. The policy shall include endorsement ISO CA 20 70 evidencing that coverage is provided for work within 50 feet of a railroad. If such endorsement is not included, railroad protective liability insurance must be provided as described in item 4 below.
4. Railroad protective liability insurance with limits of not less than \$5,000,000 combined single limit for bodily injury and/or property damage per occurrence and an aggregate annual limit of \$10,000,000, which insurance shall satisfy the following additional requirements:
 - a. The Railroad Protective Insurance Policy must be on the ISO/RIMA Form of Railroad Protective Insurance - Insurance Services Office (ISO) Form CG 00 35.
 - b. CSX Transportation must be the named insured on the Railroad Protective Insurance Policy.
 - c. Name and Address of Contractor and Agency must appear on the Declarations page.
 - d. Description of operations must appear on the Declarations page and must match the Project description.
 - e. Authorized endorsements must include the Pollution Exclusion Amendment - CG 28 31, unless using form CG 00 35 version 96 and later.
 - f. Authorized endorsements may include:
 - (i). Broad Form Nuclear Exclusion - IL 00 21
 - (ii) 30-day Advance Notice of Non-renewal or cancellation
 - (iii) Required State Cancellation Endorsement
 - (iv) Quick Reference or Index - CL/IL 240

- g. Authorized endorsements may not include:
- (i) A Pollution Exclusion Endorsement except CG 28 31
 - (ii) A Punitive or Exemplary Damages Exclusion
 - (iii) A "Common Policy Conditions" Endorsement
 - (iv) Any endorsement that is not named in Section 4 (e) or (f) above.
 - (v) Policies that contain any type of deductible

- 5. All insurance companies must be A. M. Best rated A- and Class VII or better.
- 6. The CSX OP number or CSX contract number, as applicable, must appear on each Declarations page and/or certificates of insurance.
- 7. Such additional or different insurance as CSX may require.

II. Additional Terms

- 1. Contractor must submit the complete Railroad Protective Liability policy, Certificates of Insurance and all notices and correspondence regarding the insurance policies in an electronic format to:

Insurance Department
CSX Transportation, Inc.
500 Water Street, C-907
Jacksonville, FL 32202

OR

insurancedocuments@csx.com

- 2. Neither Agency nor its Designee may begin work on or about CSX property until written approval of the required insurance has been received from CSX or CSX's Insurance Compliance vendor, Ebix.

County: ROBESON, COLUMBUS

Line #	Item Number	Sec #	Description	Quantity	Unit Cost	Amount
ROADWAY ITEMS						
0001	0000100000-N	800	MOBILIZATION	Lump Sum	L.S.	
0002	0000400000-N	801	CONSTRUCTION SURVEYING	Lump Sum	L.S.	
0003	0106000000-E	230	BORROW EXCAVATION	35 CY		
0004	0156000000-E	250	REMOVAL OF EXISTING ASPHALT PAVEMENT	6,740 SY		
0005	0318000000-E	300	FOUNDATION CONDITIONING MATERIAL, MINOR STRUCTURES	21 TON		
0006	0320000000-E	300	FOUNDATION CONDITIONING GEOTEXTILE	60 SY		
0007	0366000000-E	310	15" RC PIPE CULVERTS, CLASS III	64 LF		
0008	0372000000-E	310	18" RC PIPE CULVERTS, CLASS III	32 LF		
0009	0378000000-E	310	24" RC PIPE CULVERTS, CLASS III	32 LF		
0010	0384000000-E	310	30" RC PIPE CULVERTS, CLASS III	32 LF		
0011	0390000000-E	310	36" RC PIPE CULVERTS, CLASS III	8 LF		
0012	0582000000-E	310	15" CS PIPE CULVERTS, 0.064" THICK	4 LF		
0013	0588000000-E	310	18" CS PIPE CULVERTS, 0.064" THICK	16 LF		
0014	0996000000-N	350	PIPE CLEAN OUT	1 EA		
0015	1220000000-E	545	INCIDENTAL STONE BASE	350 TON		
0016	1245000000-E	SP	SHOULDER RECONSTRUCTION	17.35 SMI		
0017	1260000000-E	SP	AGGREGATE SHOULDER BORROW	35,595 TON		

County: ROBESON, COLUMBUS

Line #	Item Number	Sec #	Description	Quantity	Unit Cost	Amount
0018	1297000000-E	607	MILLING ASPHALT PAVEMENT, **** DEPTH (1-1/2")	24,420 SY		
0019	1297000000-E	607	MILLING ASPHALT PAVEMENT, **** DEPTH (2")	5,395 SY		
0020	1308000000-E	607	MILLING ASPHALT PAVEMENT, **** TO ***** (0-3/4" TO 1-1/2")	104,815 SY		
0021	1308000000-E	607	MILLING ASPHALT PAVEMENT, **** TO ***** (1" TO 2")	250,175 SY		
0022	1308000000-E	607	MILLING ASPHALT PAVEMENT, **** TO ***** (1" TO 3")	104,790 SY		
0023	1330000000-E	607	INCIDENTAL MILLING	12,475 SY		
0024	1491000000-E	610	ASPHALT CONC BASE COURSE, TYPE B25.0C	18,080 TON		
0025	1523000000-E	610	ASPHALT CONC SURFACE COURSE, TYPE S9.5C	54,400 TON		
0026	1575000000-E	620	ASPHALT BINDER FOR PLANT MIX	4,030 TON		
0027	1840000000-E	665	MILLED RUMBLE STRIPS (ASPHALT CONCRETE)	261,950 LF		
0028	2253000000-E	840	PIPE COLLARS	43.4 CY		
0029	2286000000-N	840	MASONRY DRAINAGE STRUCTURES	16 EA		
0030	2308000000-E	840	MASONRY DRAINAGE STRUCTURES	2.6 LF		
0031	2365000000-N	840	FRAME WITH TWO GRATES, STD 840.22	18 EA		
0032	2473000000-N	SP	GENERIC DRAINAGE ITEM CONCRETE APRON FOR DROP INLET	19 EA		
0033	2619000000-E	850	4" CONCRETE PAVED DITCH	13.7 SY		

County: ROBESON, COLUMBUS

Line #	Item Number	Sec #	Description	Quantity	Unit Cost	Amount
0034	2815000000-N	858	ADJUSTMENT OF DROP INLETS	1 EA		
0035	3001000000-N	SP	IMPACT ATTENUATOR UNITS, TYPE TL-3	2 EA		
0036	3030000000-E	862	STEEL BEAM GUARDRAIL	32,950 LF		
0037	3045000000-E	862	STEEL BEAM GUARDRAIL, SHOP CURVED	200 LF		
0038	3150000000-N	862	ADDITIONAL GUARDRAIL POSTS	40 EA		
0039	3195000000-N	862	GUARDRAIL END UNITS, TYPE AT-1	1 EA		
0040	3210000000-N	862	GUARDRAIL END UNITS, TYPE CAT-1	16 EA		
0041	3215000000-N	SP	GUARDRAIL ANCHOR UNITS, TYPE III	4 EA		
0042	3287000000-N	SP	GUARDRAIL END UNITS, TYPE TL-3	40 EA		
0043	3317000000-N	SP	GUARDRAIL ANCHOR UNITS, TYPE B-77	52 EA		
0044	3360000000-E	863	REMOVE EXISTING GUARDRAIL	35,859 LF		
0045	3503000000-E	866	WOVEN WIRE FENCE, 47" FABRIC	2,690 LF		
0046	3509000000-E	866	4" TIMBER FENCE POSTS, 7'-6" LONG	152 EA		
0047	3515000000-E	866	5" TIMBER FENCE POSTS, 8'-0" LONG	74 EA		
0048	4048000000-E	902	REINFORCED CONCRETE SIGN FOUNDATIONS	8 CY		
0049	4054000000-E	902	PLAIN CONCRETE SIGN FOUNDATIONS	1 CY		
0050	4060000000-E	903	SUPPORTS, BREAKAWAY STEEL BEAM	8,440 LB		

County: ROBESON, COLUMBUS

Line #	Item Number	Sec #	Description	Quantity	Unit Cost	Amount
0051	4072000000-E	903	SUPPORTS, 3-LB STEEL U-CHANNEL	420 LF		
0052	4096000000-N	904	SIGN ERECTION, TYPE D	3 EA		
0053	4102000000-N	904	SIGN ERECTION, TYPE E	10 EA		
0054	4108000000-N	904	SIGN ERECTION, TYPE F	2 EA		
0055	4110000000-N	904	SIGN ERECTION, TYPE *** (GROUND MOUNTED) (A)	10 EA		
0056	4110000000-N	904	SIGN ERECTION, TYPE *** (GROUND MOUNTED) (B)	8 EA		
0057	4152000000-N	907	DISPOSAL OF SIGN SYSTEM, STEEL BEAM	11 EA		
0058	4155000000-N	907	DISPOSAL OF SIGN SYSTEM, U-CHANNEL	5 EA		
0059	4400000000-E	1110	WORK ZONE SIGNS (STATIONARY)	1,680 SF		
0060	4405000000-E	1110	WORK ZONE SIGNS (PORTABLE)	576 SF		
0061	4423000000-N	SP	WORK ZONE DIGITAL SPEED LIMIT SIGNS	8 EA		
0062	4424000000-N	SP	WORK ZONE PRESENCE LIGHTING	28 EA		
0063	4434000000-N	SP	SEQUENTIAL FLASHING WARNING LIGHTS	26 EA		
0065	4600000000-N	SP	GENERIC TRAFFIC CONTROL ITEM RAMP/LOOP CLOSURES	12 EA		
0066	4600000000-N	SP	GENERIC TRAFFIC CONTROL ITEM RAMP/LOOP TRAFFIC CONTROL	12 EA		
0067	4600000000-N	SP	GENERIC TRAFFIC CONTROL ITEM SINGLE LANE CLOSURE	450 EA		
0068	4688000000-E	1205	THERMOPLASTIC PAVEMENT MARKING LINES (6", 90 MILS)	360,550 LF		

County: ROBESON, COLUMBUS

Line #	Item Number	Sec #	Description	Quantity	Unit Cost	Amount
0069	4700000000-E	1205	THERMOPLASTIC PAVEMENT MARKING LINES (12", 90 MILS)	7,350 LF		
0070	4720000000-E	1205	THERMOPLASTIC PAVEMENT MARKING CHARACTER (90 MILS)	16 EA		
0071	4725000000-E	1205	THERMOPLASTIC PAVEMENT MARKING SYMBOL (90 MILS)	79 EA		
0072	4795000000-E	1205	COLD APPLIED PLASTIC PAVEMENT MARKING LINES, TYPE ** (24") (II)	165 LF		
0073	4815000000-E	1205	PAINT PAVEMENT MARKING LINES (6")	368,570 LF		
0074	4825000000-E	1205	PAINT PAVEMENT MARKING LINES (12")	7,350 LF		
0075	4835000000-E	1205	PAINT PAVEMENT MARKING LINES (24")	165 LF		
0076	4840000000-N	1205	PAINT PAVEMENT MARKING CHARACTER	16 EA		
0077	4845000000-N	1205	PAINT PAVEMENT MARKING SYMBOL	79 EA		
0078	4847096000-E	SP	POLYUREA PAVEMENT MARKING LINES, ***, ** MILS (STANDARD GLASS BEADS) (6", 30 MILS)	8,020 LF		
0079	4905100000-N	SP	NON-CAST IRON SNOWPLOWABLE PAVEMENT MARKER	2,031 EA		
0080	6000000000-E	1605	TEMPORARY SILT FENCE	600 LF		
0081	6012000000-E	1610	SEDIMENT CONTROL STONE	200 TON		
0082	6029000000-E	SP	SAFETY FENCE	450 LF		
0083	6042000000-E	1632	1/4" HARDWARE CLOTH	1,700 LF		
0084	6071010000-E	SP	WATTLE	1,600 LF		
0085	6084000000-E	1660	SEEDING & MULCHING	4 ACR		

County: ROBESON, COLUMBUS

Line #	Item Number	Sec #	Description	Quantity	Unit Cost	Amount
0086	6117000000-N	SP	RESPONSE FOR EROSION CONTROL	10 EA		
0087	6117500000-N	SP	CONCRETE WASHOUT STRUCTURE	14 EA		
0102	4430000000-N	1130	DRUMS	150 EA		
STRUCTURE ITEMS						
0088	8664000000-E	SP	SHOTCRETE REPAIRS	4 CF		
0089	8678000000-E	SP	EPOXY RESIN INJECTION	24.6 LF		
0090	8860000000-N	SP	GENERIC STRUCTURE ITEM VOLUMETRIC MIXER	Lump Sum	L.S.	
0091	8867000000-E	SP	GENERIC STRUCTURE ITEM ASPHALT PLUG JOINT FOR PRESERVATION	379 LF		
0092	8867000000-E	SP	GENERIC STRUCTURE ITEM FOAM JOINT SEALS FOR PRESERVATION	1,546.7 LF		
0093	8882000000-E	SP	GENERIC STRUCTURE ITEM ELASTOMERIC CONCRETE FOR PRESERVATION	208.8 CF		
0094	8882000000-E	SP	GENERIC STRUCTURE ITEM REPAIRS TO PRESTRESSED CONCRETE CORED SLABS	7.4 CF		
0095	8892000000-E	SP	GENERIC STRUCTURE ITEM BRIDGE JOINT DEMOLITION	1,011.5 SF		
0096	8892000000-E	SP	GENERIC STRUCTURE ITEM SILANE BARRIER RAIL TREATMENT	18,955.9 SF		
0097	8892000000-E	SP	GENERIC STRUCTURE ITEM SURFACE PREPARATION FOR CONCRETE BARRIER RAIL	10,566.5 SF		
0098	8892000000-E	SP	GENERIC STRUCTURE ITEM SURFACE PREPARATION FOR SILANE BARRIER RAIL TREATMENT	8,389.4 SF		
0099	8893000000-E	SP	GENERIC STRUCTURE ITEM SHOTBLASTING BRIDGE DECK	13,359.7 SY		

County: ROBESON, COLUMBUS

Line #	Item Number	Sec #	Description	Quantity	Unit Cost	Amount
0100	8893000000-E	SP	GENERIC STRUCTURE ITEM SILANE DECK TREATMENT	13,359.7 SY		
0101	8897000000-N	SP	GENERIC STRUCTURE ITEM POST TENSIONING STRAND REPLACEMENT	12 EA		

1231/Dec06/Q1794388.25/D397761206000/E101

Total Amount Of Bid For Entire Project :