

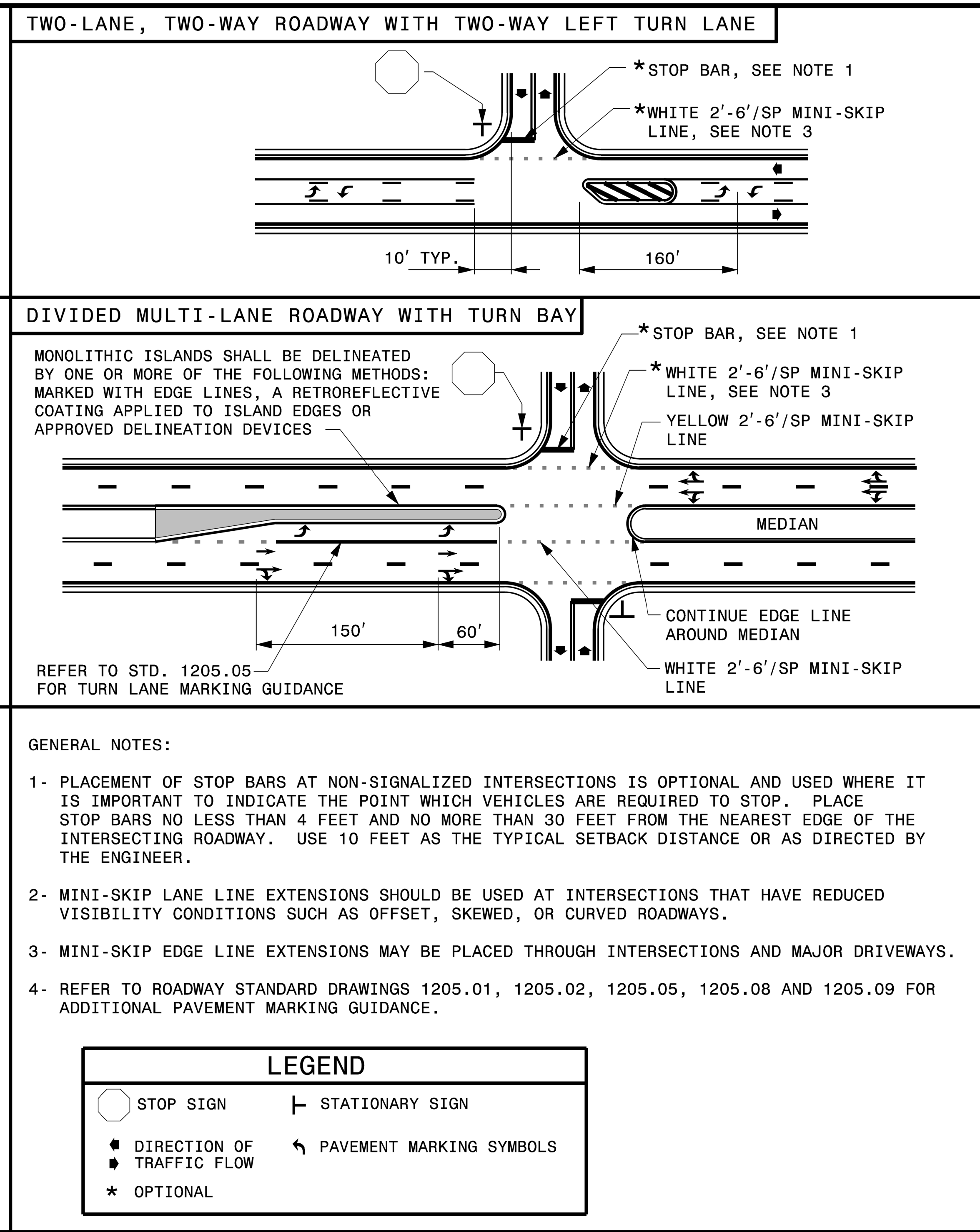

TIP NO. R-5861 DocuSign #MP-1A SHEET NO. 8/13/2019  
 APPROVED: *Matthew V. Springer*  
 DATE: 8/13/2019  
 SEAL

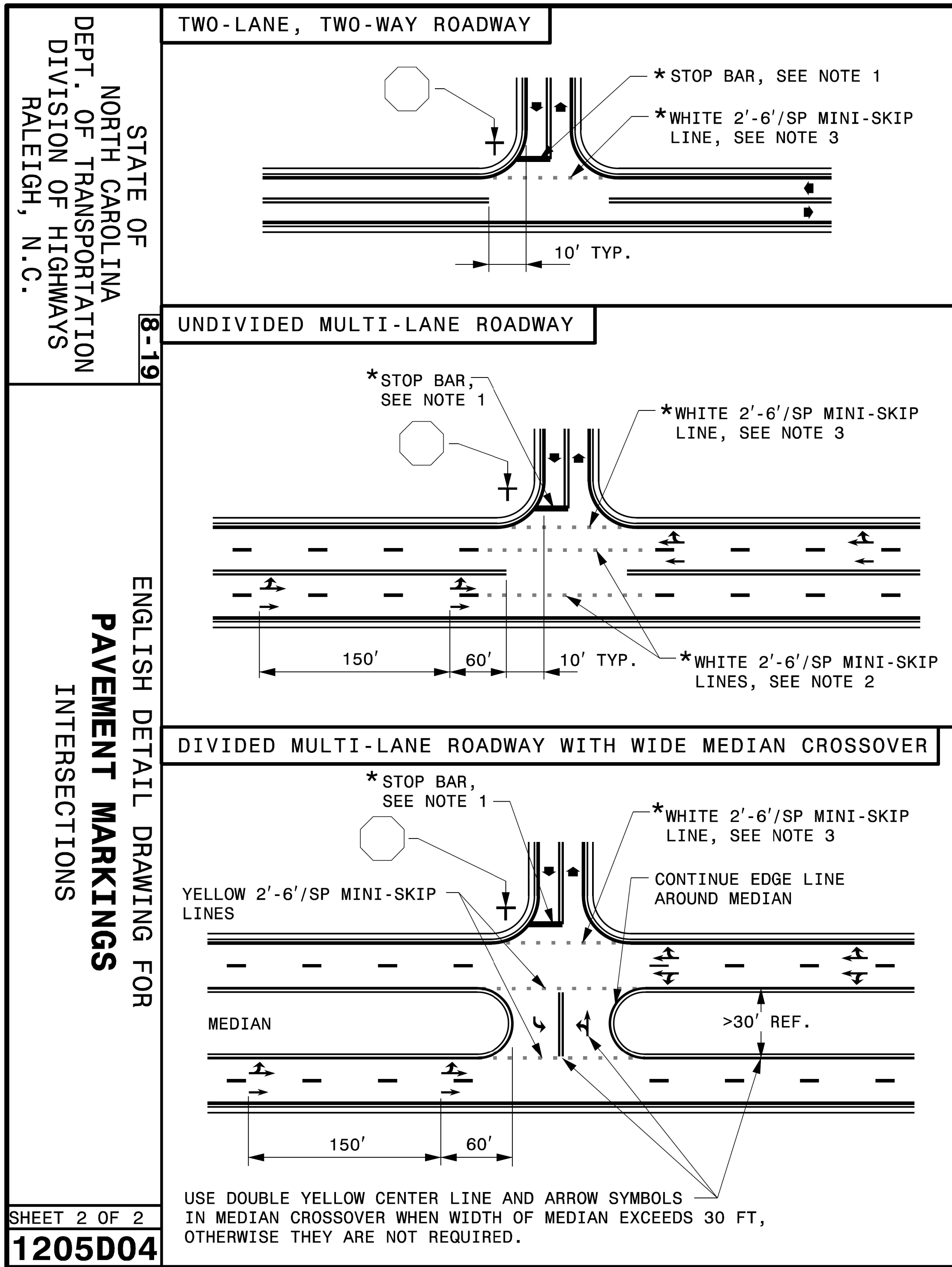

**REVISED PAVEMENT MARKING ROADWAY STANDARD DRAWING**

US/13/19 S:\S&D\Standards and Drawings\Drawings\2018 Standard Dwg\Division 12 Final\12050402\_08-13-19.dgn User:dstokes

NAD 83/2011

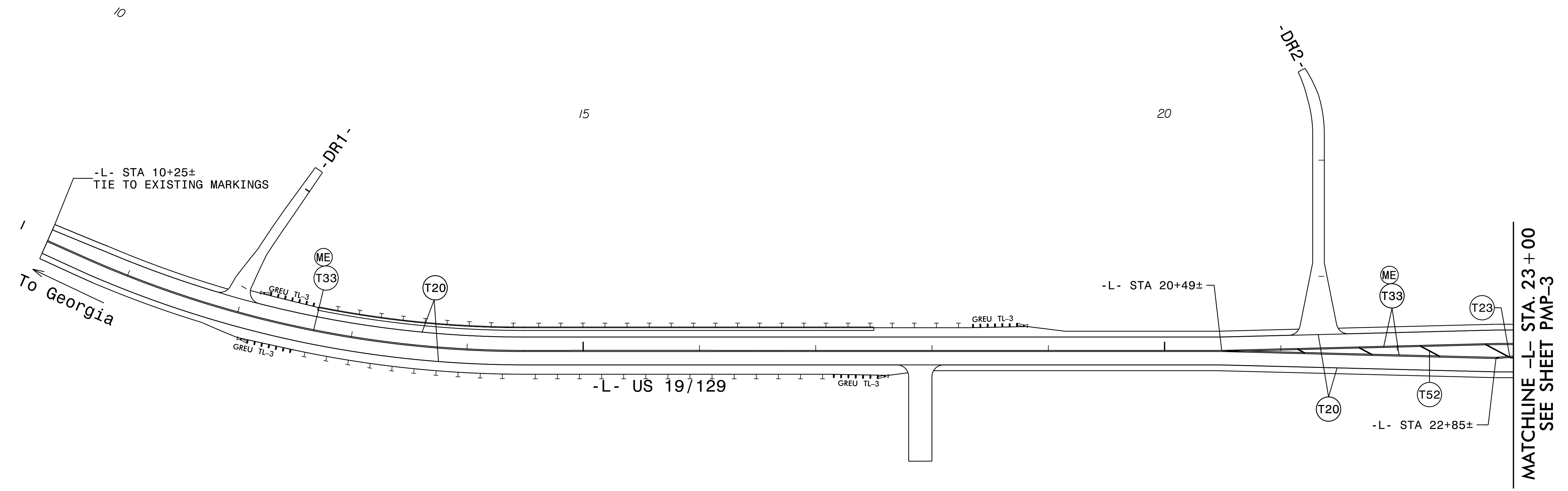

**PAVEMENT MARKING SCHEDULE**

<b>THERMOPLASTIC (4", 90 MIL)</b>		<b>THERMOPLASTIC SYMBOLS</b>	
T1	WHITE EDGE LINE	↶	T70 LEFT TURN ARROW
T2	WHITE SOLID LANE LINE	↷	T71 RIGHT TURN ARROW
T5	2 FT. - 6 FT./SP WHITE MINI-SKIP	↑	T72 STRAIGHT ARROW
T13	YELLOW DOUBLE CENTER	↙	T73 LEFT/STRAIGHT ARROW
<b>THERMOPLASTIC (6", 90 MIL)</b>		↘	T74 RIGHT/STRAIGHT ARROW
T20	WHITE EDGE LINE	↘	T79 MERGE ARROW
T21	WHITE SOLID LANE LINE	▼▼▼	T103 YIELD LINE TRIANGLE
T22	10 FT. WHITE SKIP	<b>SNOWPLOWABLE PAVEMENT MARKERS</b>	
T23	3 FT. - 9 FT./SP WHITE MINI-SKIP	ME	YELLOW/YELLOW
T24	2 FT. - 6 FT./SP WHITE MINI-SKIP	MF	CRYSTAL RED
T30	YELLOW EDGE LINE		
T33	YELLOW DOUBLE CENTER		
<b>THERMOPLASTIC (12", 90 MIL)</b>			
T50	WHITE GORE LINE		
T52	YELLOW DIAGONAL		
<b>THERMOPLASTIC (24", 90 MIL)</b>			
T61	WHITE STOP BAR		
T62	WHITE CROSSWALK LINE		

ALL LANE WIDTHS 12' UNLESS OTHERWISE NOTED.  
TRANSITION FROM 6" MARKINGS TO 4" MARKINGS AT THE MIDPOINT OF THE RADIUS OR STOP BAR AS APPLICABLE AT INTERSECTIONS.

**PAVEMENT MARKING DETAIL**

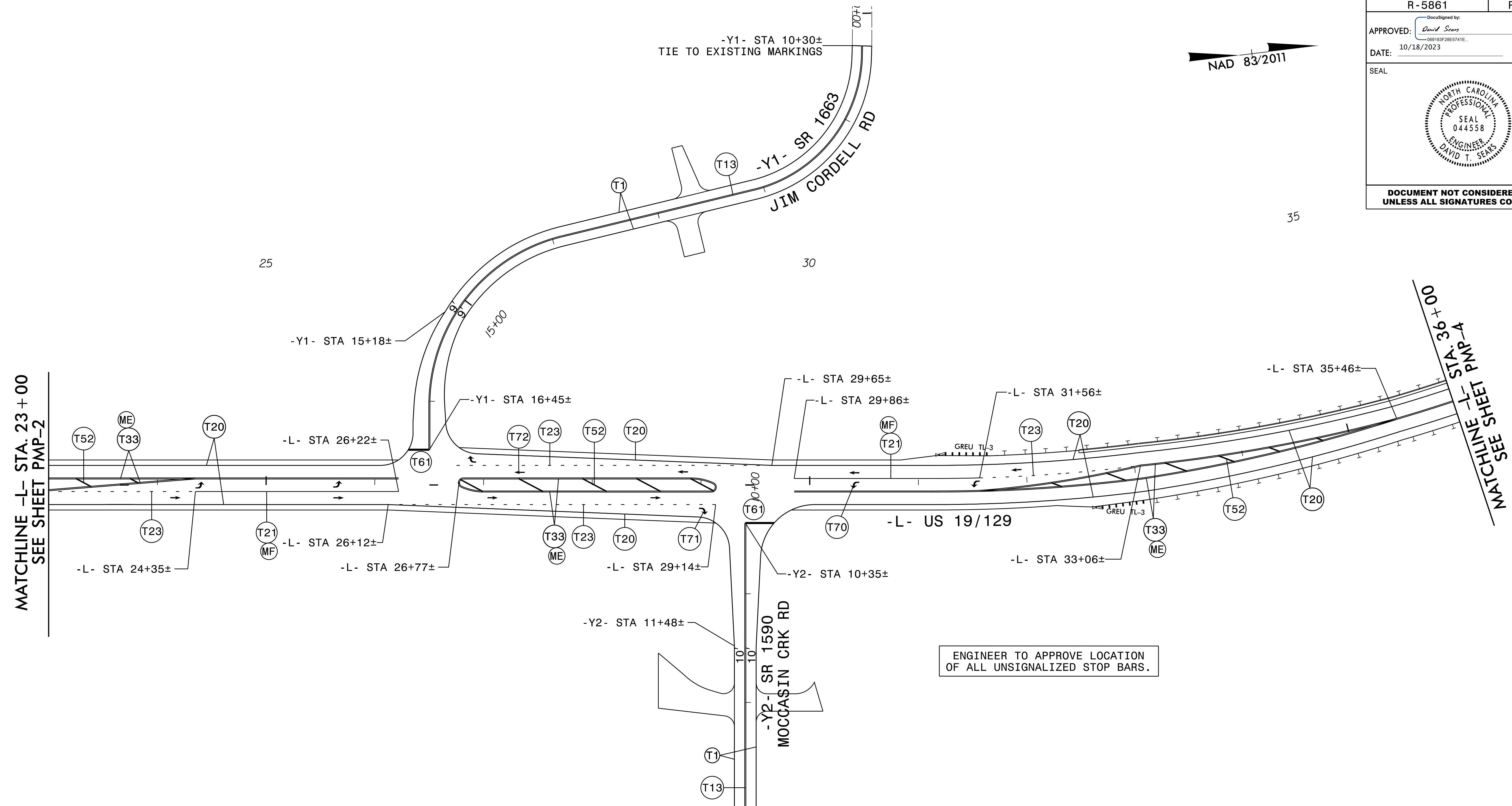
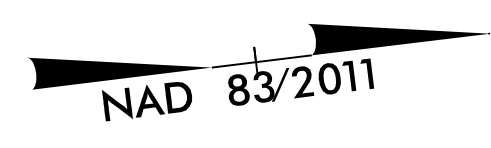

MATCHLINE -L- STA. 23+00  
SEE SHEET PMP-2

MATCHLINE -L- STA. 36+00  
SEE SHEET PMP-4

**PAVEMENT MARKING SCHEDULE**

<b>THERMOPLASTIC (4", 90 MIL)</b>		<b>THERMOPLASTIC SYMBOLS</b>	
T1	WHITE EDGE LINE	↩ T70	LEFT TURN ARROW
T2	WHITE SOLID LANE LINE	↪ T71	RIGHT TURN ARROW
T5	2 FT. - 6 FT./SP WHITE MINI-SKIP	↑ T72	STRAIGHT ARROW
T13	YELLOW DOUBLE CENTER	↙ T73	LEFT/STRAIGHT ARROW
<b>THERMOPLASTIC (6", 90 MIL)</b>		↘ T74	RIGHT/STRAIGHT ARROW
T20	WHITE EDGE LINE	↘ T79	MERGE ARROW
T21	WHITE SOLID LANE LINE	▼▼▼▼ T103	YIELD LINE TRIANGLE
T22	10 FT. WHITE SKIP	<b>SNOWPLOWABLE PAVEMENT MARKERS</b>	
T23	3 FT. - 9 FT./SP WHITE MINI-SKIP	ME	YELLOW/YELLOW
T24	2 FT. - 6 FT./SP WHITE MINI-SKIP	MF	CRYSTAL RED
T30	YELLOW EDGE LINE		
T33	YELLOW DOUBLE CENTER		
<b>THERMOPLASTIC (12", 90 MIL)</b>			
T50	WHITE GORE LINE		
T52	YELLOW DIAGONAL		
<b>THERMOPLASTIC (24", 90 MIL)</b>			
T61	WHITE STOP BAR		
T62	WHITE CROSSWALK LINE		

ENGINEER TO APPROVE LOCATION  
OF ALL UNSIGNALIZED STOP BARS.

ALL LANE WIDTHS 12' UNLESS OTHERWISE NOTED.  
TRANSITION FROM 6" MARKINGS TO 4" MARKINGS  
AT THE MIDPOINT OF THE RADIUS OR STOP BAR  
AS APPLICABLE AT INTERSECTIONS.

PAVEMENT MARKING DETAIL

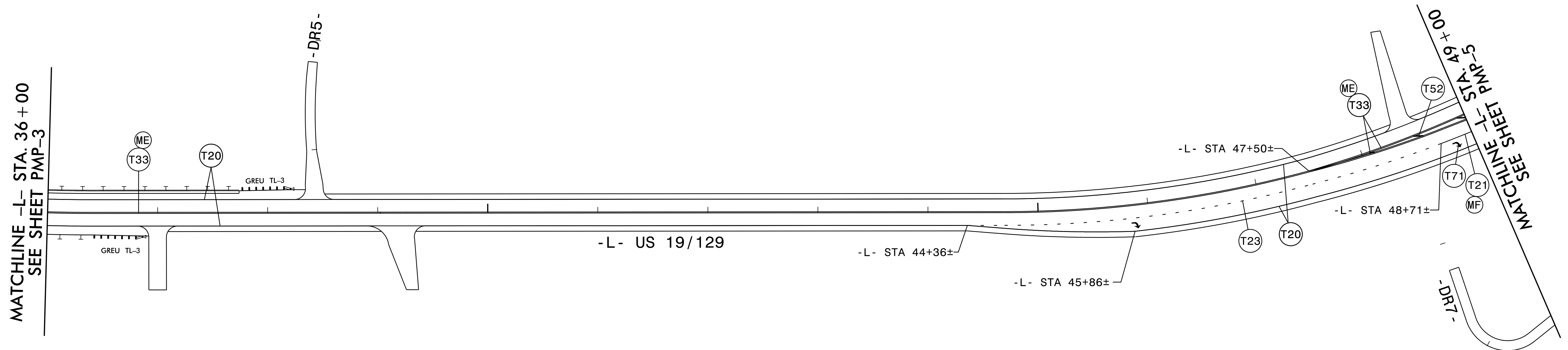
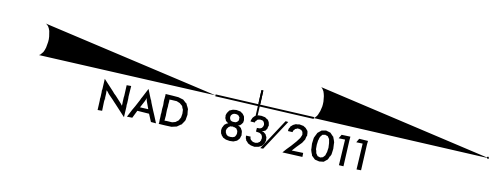

**PAVEMENT MARKING SCHEDULE**

<b>THERMOPLASTIC (4", 90 MIL)</b>		<b>THERMOPLASTIC SYMBOLS</b>	
T1	WHITE EDGE LINE	↶	T70 LEFT TURN ARROW
T2	WHITE SOLID LANE LINE	↷	T71 RIGHT TURN ARROW
T5	2 FT. - 6 FT./SP WHITE MINI-SKIP	↑	T72 STRAIGHT ARROW
T13	YELLOW DOUBLE CENTER	↙↘	T73 LEFT/STRAIGHT ARROW
<b>THERMOPLASTIC (6", 90 MIL)</b>		↘↙	T74 RIGHT/STRAIGHT ARROW
T20	WHITE EDGE LINE	↘	T79 MERGE ARROW
T21	WHITE SOLID LANE LINE	▼▼▼	T103 YIELD LINE TRIANGLE
T22	10 FT. WHITE SKIP	<b>SNOWPLOWABLE PAVEMENT MARKERS</b>	
T23	3 FT. - 9 FT./SP WHITE MINI-SKIP	ME	YELLOW/YELLOW
T24	2 FT. - 6 FT./SP WHITE MINI-SKIP	MF	CRYSTAL RED
T30	YELLOW EDGE LINE		
T33	YELLOW DOUBLE CENTER		
<b>THERMOPLASTIC (12", 90 MIL)</b>			
T50	WHITE GORE LINE		
T52	YELLOW DIAGONAL		
<b>THERMOPLASTIC (24", 90 MIL)</b>			
T61	WHITE STOP BAR		
T62	WHITE CROSSWALK LINE		

ALL LANE WIDTHS 12' UNLESS OTHERWISE NOTED.  
TRANSITION FROM 6" MARKINGS TO 4" MARKINGS AT THE MIDPOINT OF THE RADIUS OR STOP BAR AS APPLICABLE AT INTERSECTIONS.

**PAVEMENT MARKING DETAIL**

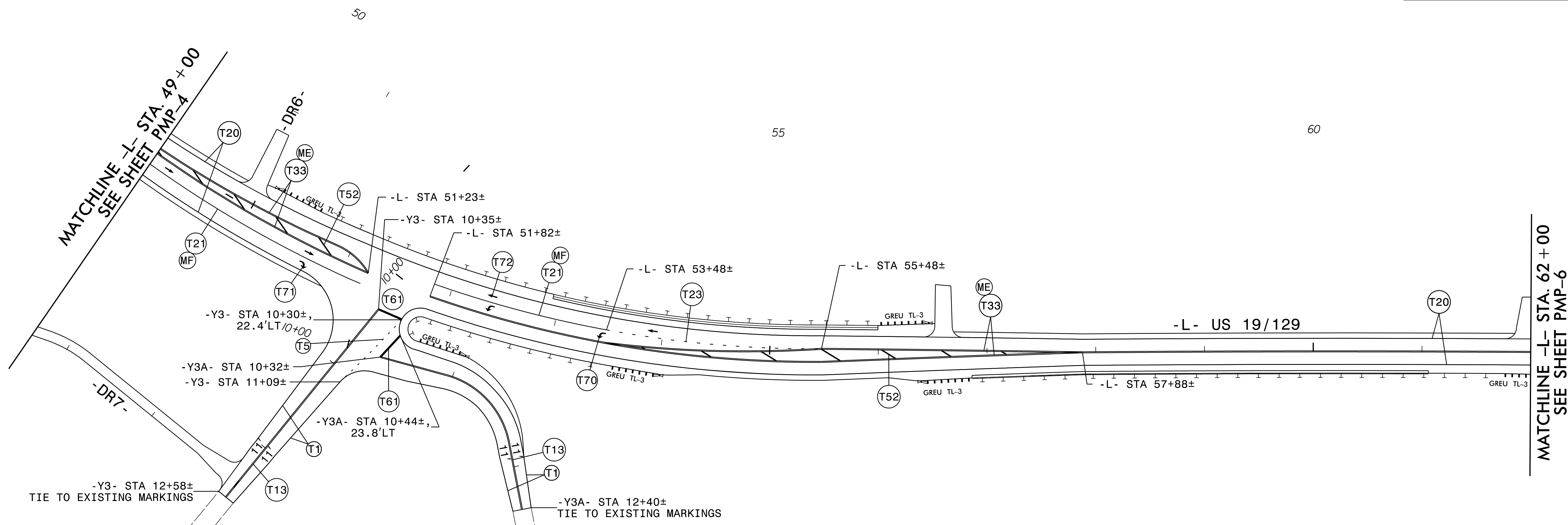

ENGINEER TO APPROVE LOCATION  
OF ALL UNSIGNALIZED STOP BARS.

### PAVEMENT MARKING SCHEDULE

THERMOPLASTIC (4", 90 MIL)		THERMOPLASTIC SYMBOLS	
T1	WHITE EDGE LINE	↶	T70 LEFT TURN ARROW
T2	WHITE SOLID LANE LINE	↷	T71 RIGHT TURN ARROW
T5	2 FT. - 6 FT./SP WHITE MINI-SKIP	↑	T72 STRAIGHT ARROW
T13	YELLOW DOUBLE CENTER	↶↷	T73 LEFT/STRAIGHT ARROW
THERMOPLASTIC (6", 90 MIL)		↷↶	T74 RIGHT/STRAIGHT ARROW
T20	WHITE EDGE LINE	↘	T79 MERGE ARROW
T21	WHITE SOLID LANE LINE	▲	T103 YIELD LINE TRIANGLE
T22	10 FT. WHITE SKIP		
T23	3 FT. - 9 FT./SP WHITE MINI-SKIP		
T24	2 FT. - 6 FT./SP WHITE MINI-SKIP		
T30	YELLOW EDGE LINE		
T33	YELLOW DOUBLE CENTER		
THERMOPLASTIC (12", 90 MIL)		SNOWPLOWABLE PAVEMENT MARKERS	
T50	WHITE GORE LINE	ME	YELLOW/YELLOW
T52	YELLOW DIAGONAL	MF	CRYSTAL RED
THERMOPLASTIC (24", 90 MIL)			
T61	WHITE STOP BAR		
T62	WHITE CROSSWALK LINE		

ALL LANE WIDTHS 12' UNLESS OTHERWISE NOTED.  
TRANSITION FROM 6" MARKINGS TO 4" MARKINGS  
AT THE MIDPOINT OF THE RADIUS OR STOP BAR  
AS APPLICABLE AT INTERSECTIONS.

PAVEMENT MARKING DETAIL

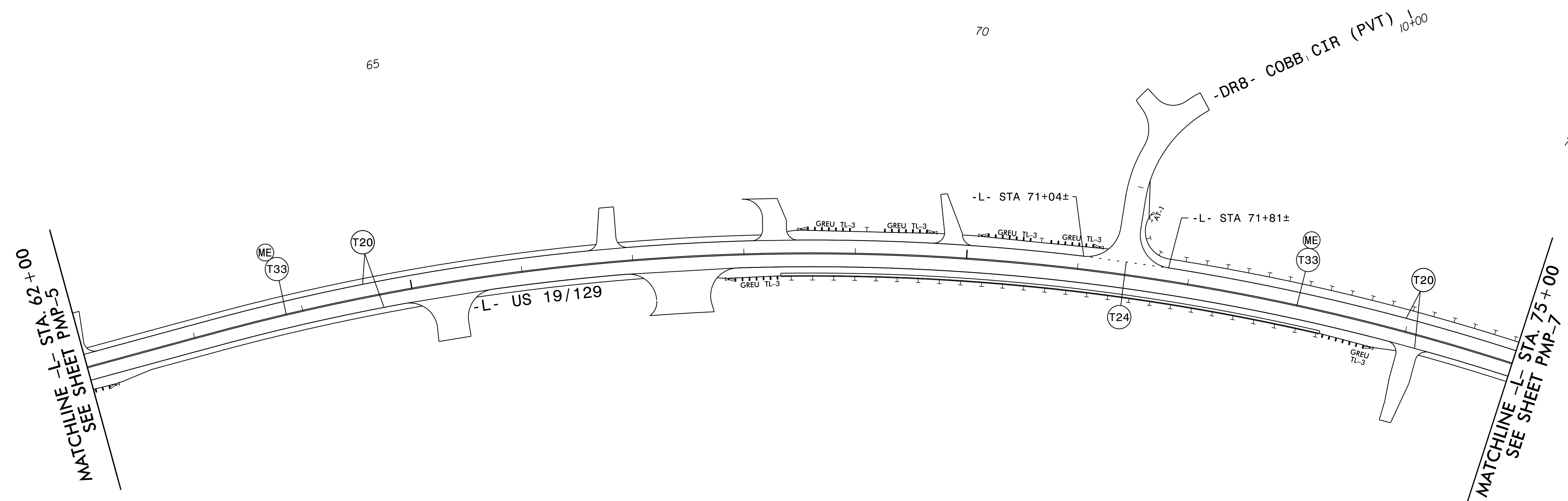
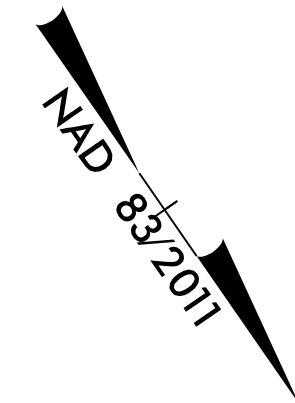

**PAVEMENT MARKING SCHEDULE**

<b>THERMOPLASTIC (4", 90 MIL)</b>		<b>THERMOPLASTIC SYMBOLS</b>	
T1	WHITE EDGE LINE	↶	T70 LEFT TURN ARROW
T2	WHITE SOLID LANE LINE	↷	T71 RIGHT TURN ARROW
T5	2 FT. - 6 FT./SP WHITE MINI-SKIP	↑	T72 STRAIGHT ARROW
T13	YELLOW DOUBLE CENTER	↙	T73 LEFT/STRAIGHT ARROW
<b>THERMOPLASTIC (6", 90 MIL)</b>		↘	T74 RIGHT/STRAIGHT ARROW
T20	WHITE EDGE LINE	↘	T79 MERGE ARROW
T21	WHITE SOLID LANE LINE	▼▼▼	T103 YIELD LINE TRIANGLE
T22	10 FT. WHITE SKIP	<b>SNOWPLOWABLE PAVEMENT MARKERS</b>	
T23	3 FT. - 9 FT./SP WHITE MINI-SKIP	ME	YELLOW/YELLOW
T24	2 FT. - 6 FT./SP WHITE MINI-SKIP	MF	CRYSTAL RED
T30	YELLOW EDGE LINE		
T33	YELLOW DOUBLE CENTER		
<b>THERMOPLASTIC (12", 90 MIL)</b>			
T50	WHITE GORE LINE		
T52	YELLOW DIAGONAL		
<b>THERMOPLASTIC (24", 90 MIL)</b>			
T61	WHITE STOP BAR		
T62	WHITE CROSSWALK LINE		

ALL LANE WIDTHS 12' UNLESS OTHERWISE NOTED.  
TRANSITION FROM 6" MARKINGS TO 4" MARKINGS AT THE MIDPOINT OF THE RADIUS OR STOP BAR AS APPLICABLE AT INTERSECTIONS.

**PAVEMENT MARKING DETAIL**

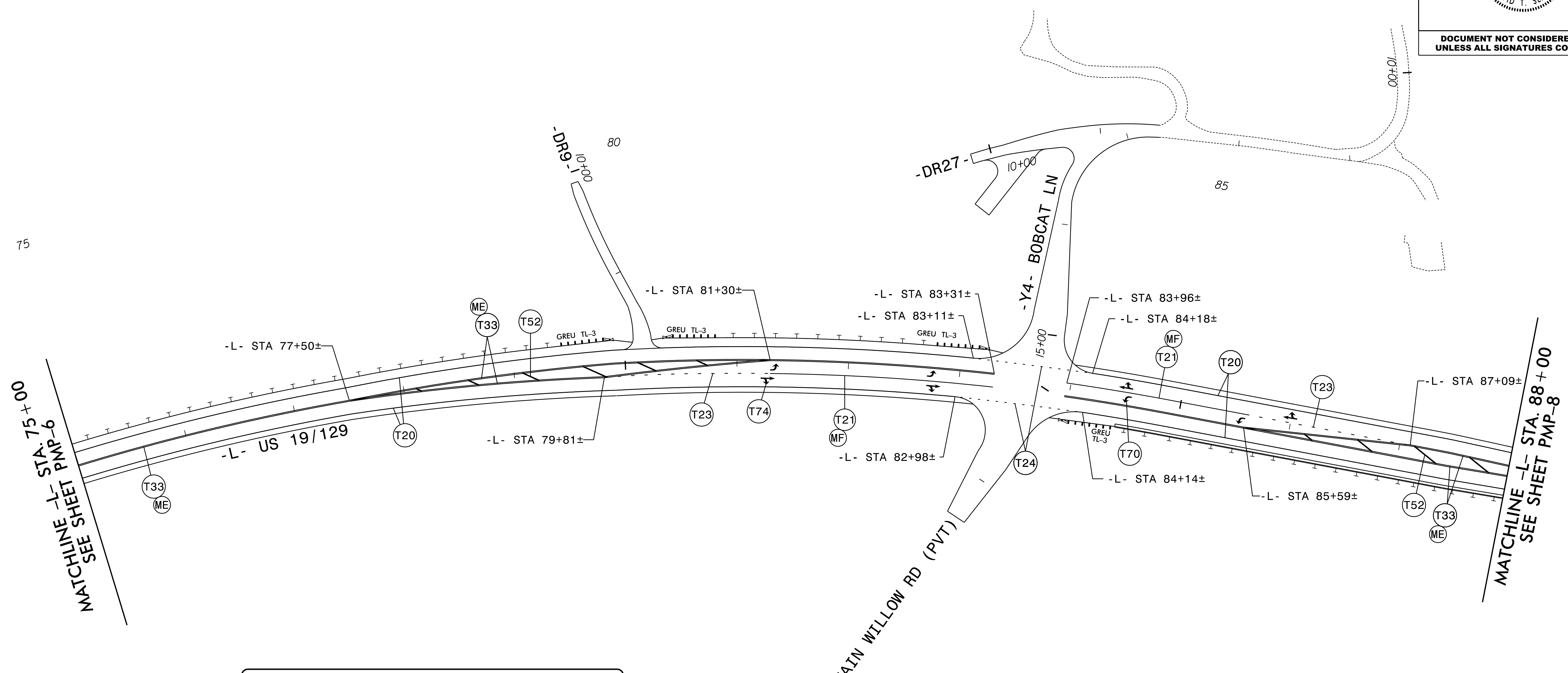

**PAVEMENT MARKING SCHEDULE**

THERMOPLASTIC (4", 90 MIL)		THERMOPLASTIC SYMBOLS	
T1	WHITE EDGE LINE	↶	T70 LEFT TURN ARROW
T2	WHITE SOLID LANE LINE	↷	T71 RIGHT TURN ARROW
T5	2 FT. - 6 FT./SP WHITE MINI-SKIP	↑	T72 STRAIGHT ARROW
T13	YELLOW DOUBLE CENTER	↶↷	T73 LEFT/STRAIGHT ARROW
THERMOPLASTIC (6", 90 MIL)		↷↶	T74 RIGHT/STRAIGHT ARROW
T20	WHITE EDGE LINE	↘	T79 MERGE ARROW
T21	WHITE SOLID LANE LINE	▼▼▼▼	T103 YIELD LINE TRIANGLE
T22	10 FT. WHITE SKIP		
T23	3 FT. - 9 FT./SP WHITE MINI-SKIP		
T24	2 FT. - 6 FT./SP WHITE MINI-SKIP		
T30	YELLOW EDGE LINE		
T33	YELLOW DOUBLE CENTER		
THERMOPLASTIC (12", 90 MIL)		SNOWPLOWABLE PAVEMENT MARKERS	
T50	WHITE GORE LINE	ME	YELLOW/YELLOW
T52	YELLOW DIAGONAL	MF	CRYSTAL RED
THERMOPLASTIC (24", 90 MIL)			
T61	WHITE STOP BAR		
T62	WHITE CROSSWALK LINE		

ALL LANE WIDTHS 12' UNLESS OTHERWISE NOTED.  
TRANSITION FROM 6" MARKINGS TO 4" MARKINGS AT THE MIDPOINT OF THE RADIUS OR STOP BAR AS APPLICABLE AT INTERSECTIONS.

**PAVEMENT MARKING DETAIL**





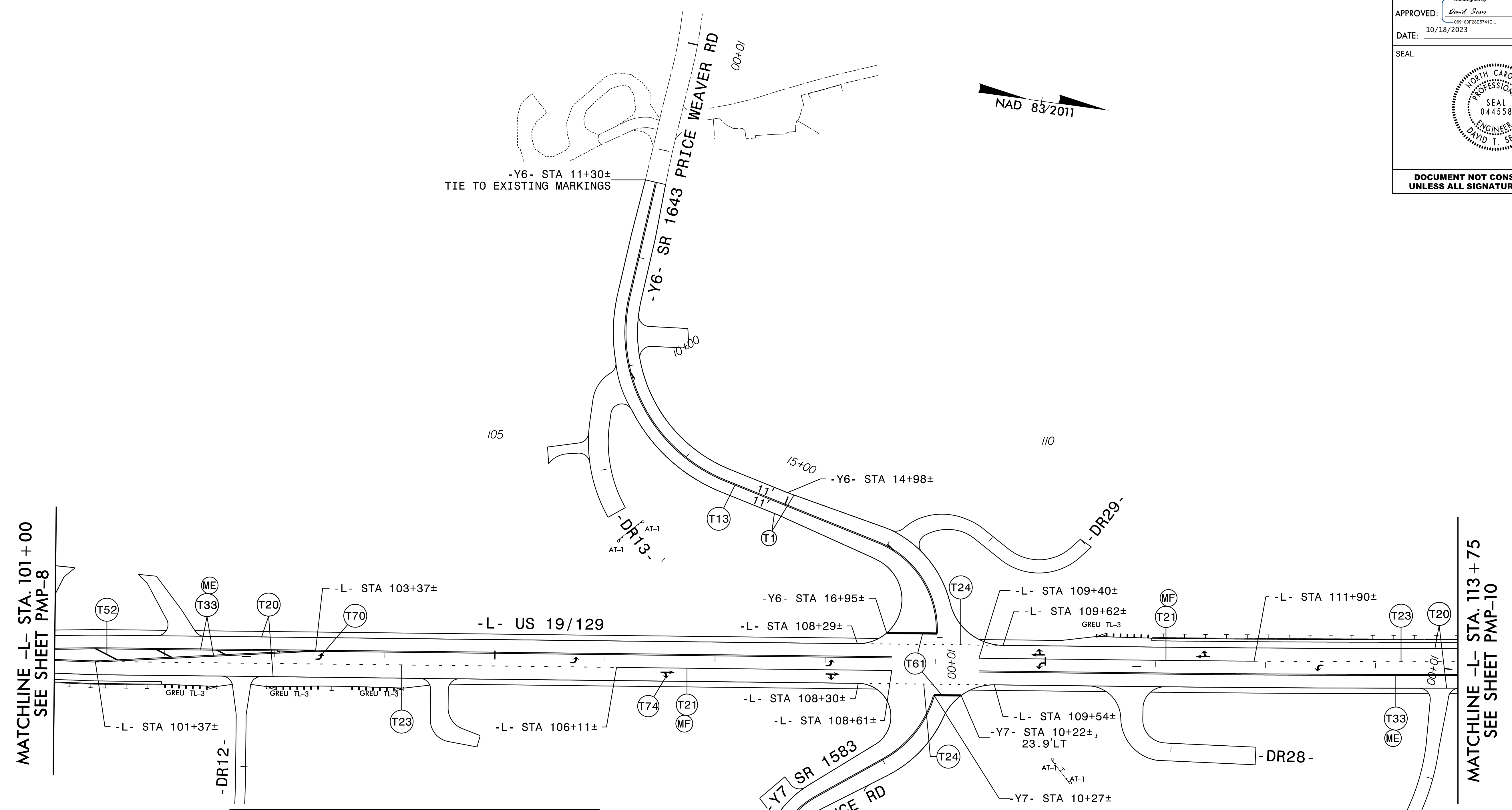

**PAVEMENT MARKING SCHEDULE**

<b>THERMOPLASTIC (4", 90 MIL)</b>		<b>THERMOPLASTIC SYMBOLS</b>	
T1	WHITE EDGE LINE	↶	T70 LEFT TURN ARROW
T2	WHITE SOLID LANE LINE	↷	T71 RIGHT TURN ARROW
T5	2 FT. - 6 FT./SP WHITE MINI-SKIP	↑	T72 STRAIGHT ARROW
T13	YELLOW DOUBLE CENTER	↶↷	T73 LEFT/STRAIGHT ARROW
<b>THERMOPLASTIC (6", 90 MIL)</b>		↷↶	T74 RIGHT/STRAIGHT ARROW
T20	WHITE EDGE LINE	↘	T79 MERGE ARROW
T21	WHITE SOLID LANE LINE	▼▼▼	T103 YIELD LINE TRIANGLE
T22	10 FT. WHITE SKIP	<b>SNOWPLOWABLE PAVEMENT MARKERS</b>	
T23	3 FT. - 9 FT./SP WHITE MINI-SKIP	ME	YELLOW/YELLOW
T24	2 FT. - 6 FT./SP WHITE MINI-SKIP	MF	CRYSTAL RED
T30	YELLOW EDGE LINE		
T33	YELLOW DOUBLE CENTER		
<b>THERMOPLASTIC (12", 90 MIL)</b>			
T50	WHITE GORE LINE		
T52	YELLOW DIAGONAL		
<b>THERMOPLASTIC (24", 90 MIL)</b>			
T61	WHITE STOP BAR		
T62	WHITE CROSSWALK LINE		

ENGINEER TO APPROVE LOCATION OF ALL UNSIGNALIZED STOP BARS.

ALL LANE WIDTHS 12' UNLESS OTHERWISE NOTED.  
TRANSITION FROM 6" MARKINGS TO 4" MARKINGS AT THE MIDPOINT OF THE RADIUS OR STOP BAR AS APPLICABLE AT INTERSECTIONS.

PAVEMENT MARKING DETAIL

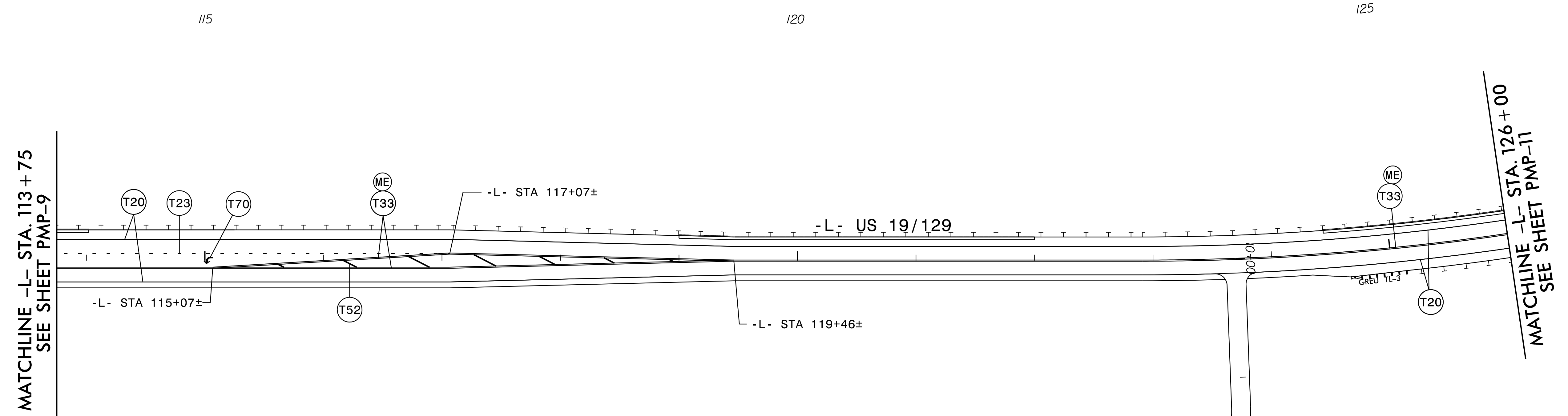
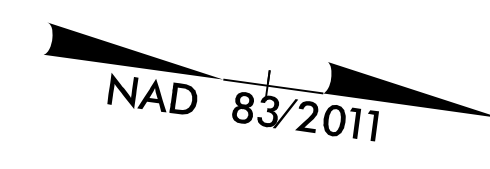

### PAVEMENT MARKING SCHEDULE

<b>THERMOPLASTIC (4", 90 MIL)</b>		<b>THERMOPLASTIC SYMBOLS</b>	
T1	WHITE EDGE LINE	↶	T70 LEFT TURN ARROW
T2	WHITE SOLID LANE LINE	↷	T71 RIGHT TURN ARROW
T5	2 FT. - 6 FT./SP WHITE MINI-SKIP	↑	T72 STRAIGHT ARROW
T13	YELLOW DOUBLE CENTER	↶↷	T73 LEFT/STRAIGHT ARROW
<b>THERMOPLASTIC (6", 90 MIL)</b>		↷↶	T74 RIGHT/STRAIGHT ARROW
T20	WHITE EDGE LINE	↘	T79 MERGE ARROW
T21	WHITE SOLID LANE LINE	▼▼▼▼	T103 YIELD LINE TRIANGLE
T22	10 FT. WHITE SKIP		
T23	3 FT. - 9 FT./SP WHITE MINI-SKIP		
T24	2 FT. - 6 FT./SP WHITE MINI-SKIP		
T30	YELLOW EDGE LINE		
T33	YELLOW DOUBLE CENTER		
<b>THERMOPLASTIC (12", 90 MIL)</b>			
T50	WHITE GORE LINE		
T52	YELLOW DIAGONAL		
<b>THERMOPLASTIC (24", 90 MIL)</b>		<b>SNOWPLOWABLE PAVEMENT MARKERS</b>	
T61	WHITE STOP BAR	ME	YELLOW/YELLOW
T62	WHITE CROSSWALK LINE	MF	CRYSTAL RED

ALL LANE WIDTHS 12' UNLESS OTHERWISE NOTED.  
TRANSITION FROM 6" MARKINGS TO 4" MARKINGS AT THE MIDPOINT OF THE RADIUS OR STOP BAR AS APPLICABLE AT INTERSECTIONS.

### PAVEMENT MARKING DETAIL

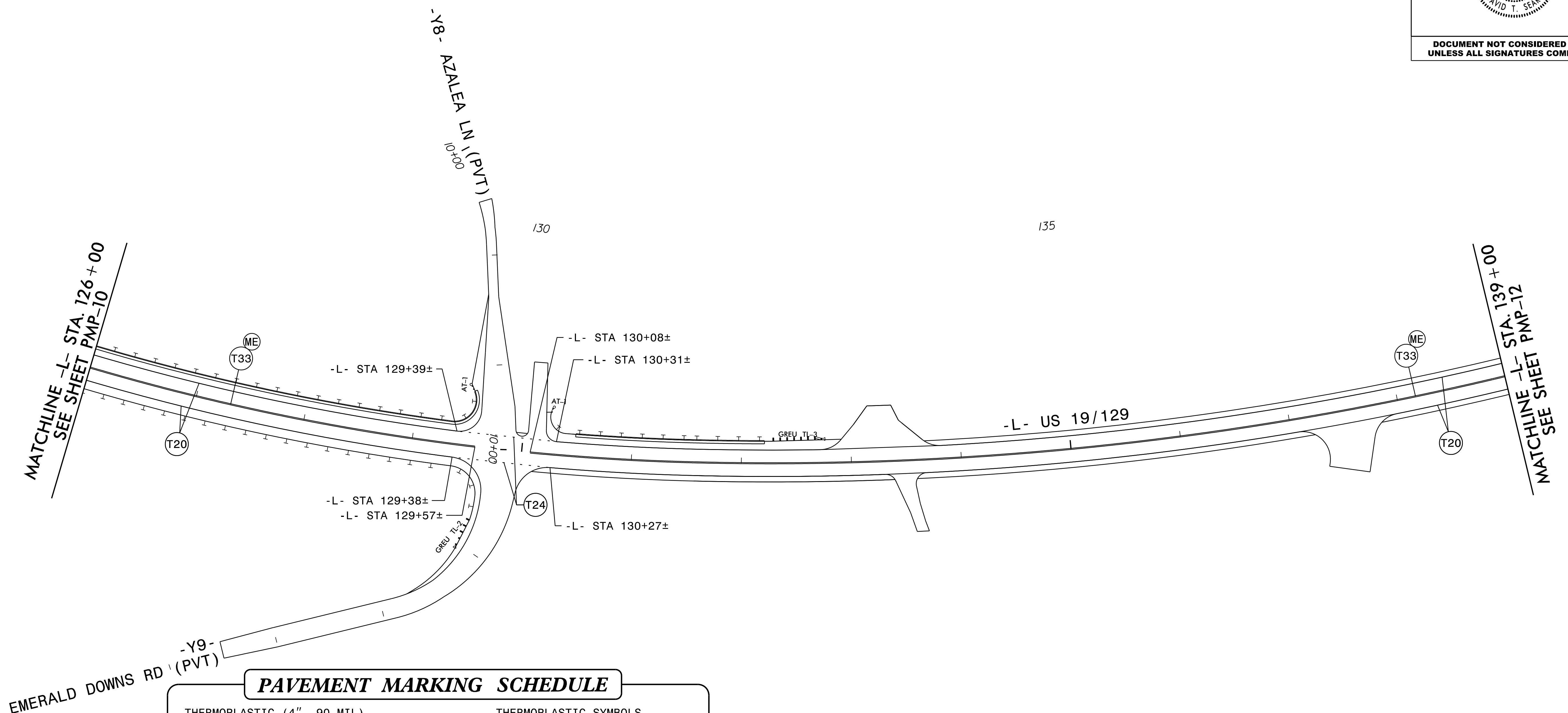

**PAVEMENT MARKING SCHEDULE**

<b>THERMOPLASTIC (4", 90 MIL)</b>		<b>THERMOPLASTIC SYMBOLS</b>	
T1	WHITE EDGE LINE	↶	T70 LEFT TURN ARROW
T2	WHITE SOLID LANE LINE	↷	T71 RIGHT TURN ARROW
T5	2 FT. - 6 FT./SP WHITE MINI-SKIP	↑	T72 STRAIGHT ARROW
T13	YELLOW DOUBLE CENTER	↶↷	T73 LEFT/STRAIGHT ARROW
<b>THERMOPLASTIC (6", 90 MIL)</b>		↷↶	T74 RIGHT/STRAIGHT ARROW
T20	WHITE EDGE LINE	↘	T79 MERGE ARROW
T21	WHITE SOLID LANE LINE	▼▼▼	T103 YIELD LINE TRIANGLE
T22	10 FT. WHITE SKIP	<b>SNOWPLOWABLE PAVEMENT MARKERS</b>	
T23	3 FT. - 9 FT./SP WHITE MINI-SKIP	ME	YELLOW/YELLOW
T24	2 FT. - 6 FT./SP WHITE MINI-SKIP	MF	CRYSTAL RED
T30	YELLOW EDGE LINE	<b>THERMOPLASTIC (24", 90 MIL)</b>	
T33	YELLOW DOUBLE CENTER	T61	WHITE STOP BAR
<b>THERMOPLASTIC (12", 90 MIL)</b>		T62	WHITE CROSSWALK LINE
T50	WHITE GORE LINE		
T52	YELLOW DIAGONAL		

ALL LANE WIDTHS 12' UNLESS OTHERWISE NOTED.  
TRANSITION FROM 6" MARKINGS TO 4" MARKINGS AT THE MIDPOINT OF THE RADIUS OR STOP BAR AS APPLICABLE AT INTERSECTIONS.

**PAVEMENT MARKING DETAIL**

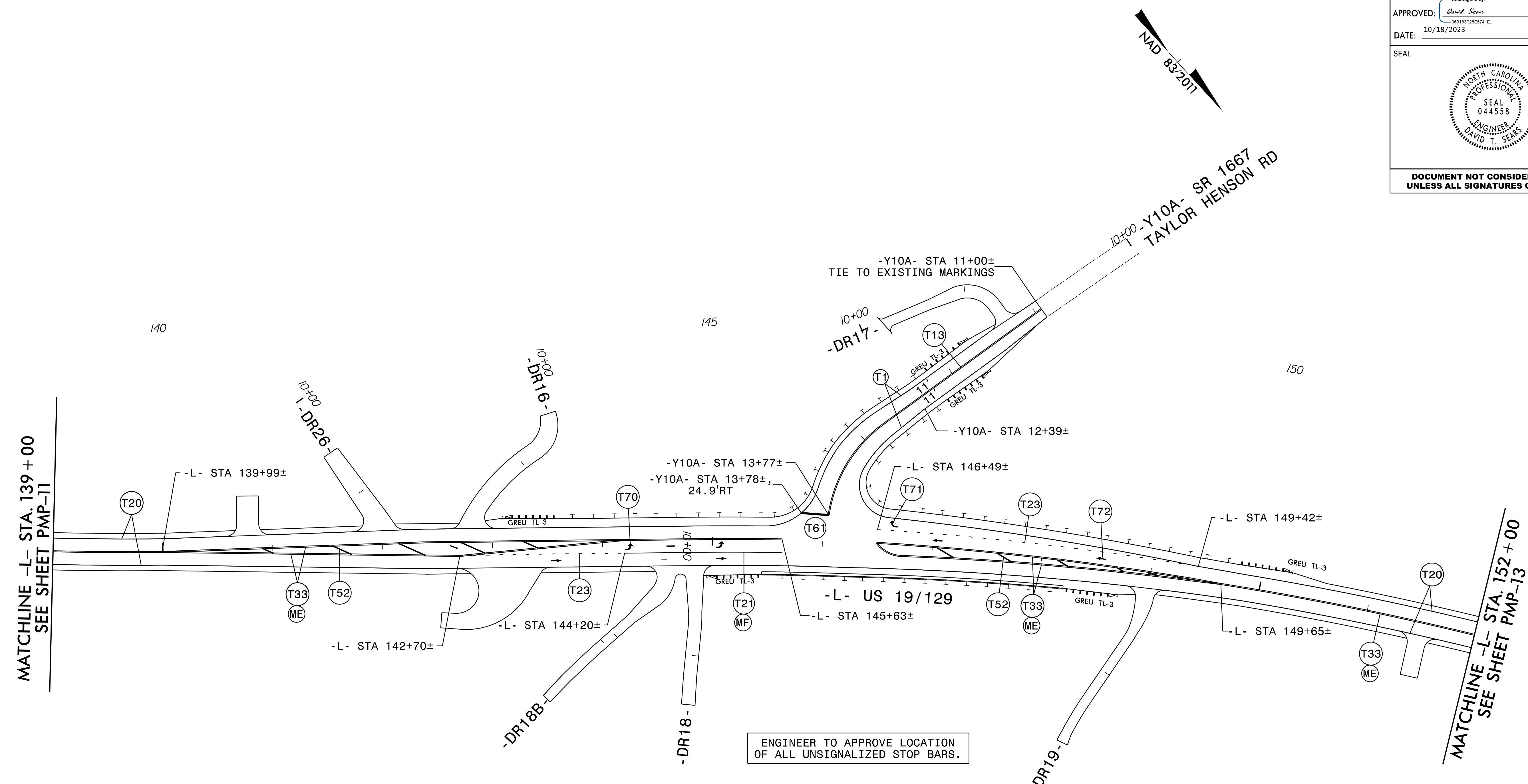

**PAVEMENT MARKING SCHEDULE**

<b>THERMOPLASTIC (4", 90 MIL)</b>		<b>THERMOPLASTIC SYMBOLS</b>	
T1	WHITE EDGE LINE	↙	T70 LEFT TURN ARROW
T2	WHITE SOLID LANE LINE	↘	T71 RIGHT TURN ARROW
T5	2 FT. - 6 FT./SP WHITE MINI-SKIP	↑	T72 STRAIGHT ARROW
T13	YELLOW DOUBLE CENTER	↙↘	T73 LEFT/STRAIGHT ARROW
<b>THERMOPLASTIC (6", 90 MIL)</b>		↘↙	T74 RIGHT/STRAIGHT ARROW
T20	WHITE EDGE LINE	↘↙	T79 MERGE ARROW
T21	WHITE SOLID LANE LINE	▼▼▼	T103 YIELD LINE TRIANGLE
T22	10 FT. WHITE SKIP		
T23	3 FT. - 9 FT./SP WHITE MINI-SKIP		
T24	2 FT. - 6 FT./SP WHITE MINI-SKIP		
T30	YELLOW EDGE LINE		
T33	YELLOW DOUBLE CENTER		
<b>THERMOPLASTIC (12", 90 MIL)</b>		<b>SNOWPLOWABLE PAVEMENT MARKERS</b>	
T50	WHITE GORE LINE	ME	YELLOW/YELLOW
T52	YELLOW DIAGONAL	MF	CRYSTAL RED
<b>THERMOPLASTIC (24", 90 MIL)</b>			
T61	WHITE STOP BAR		
T62	WHITE CROSSWALK LINE		

ALL LANE WIDTHS 12' UNLESS OTHERWISE NOTED.  
TRANSITION FROM 6" MARKINGS TO 4" MARKINGS AT THE MIDPOINT OF THE RADIUS OR STOP BAR AS APPLICABLE AT INTERSECTIONS.

**PAVEMENT MARKING DETAIL**

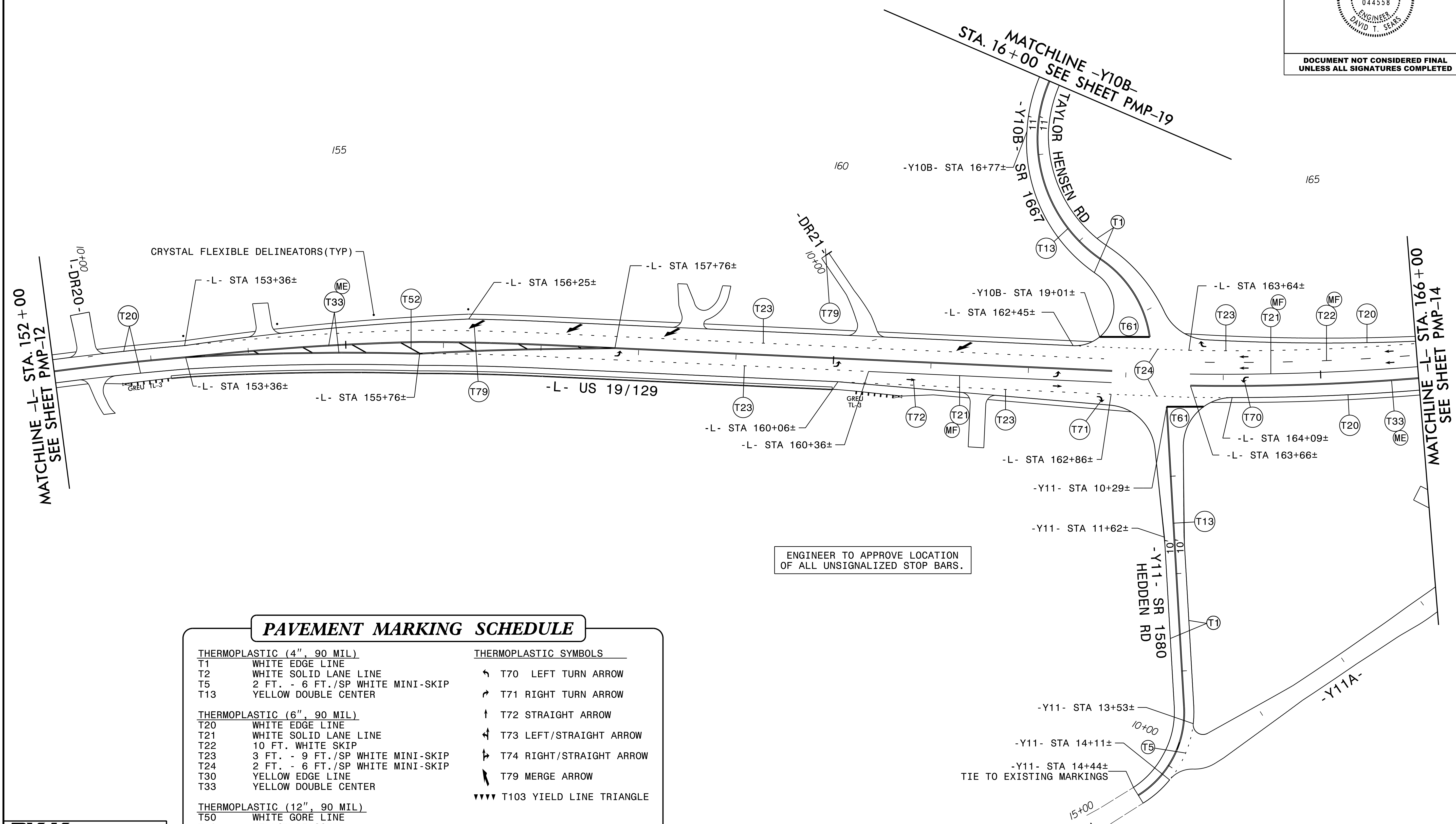

ENGINEER TO APPROVE LOCATION  
OF ALL UNSIGNALIZED STOP BARS.

**PAVEMENT MARKING SCHEDULE**

<b>THERMOPLASTIC (4", 90 MIL)</b>		<b>THERMOPLASTIC SYMBOLS</b>	
T1	WHITE EDGE LINE	↶	T70 LEFT TURN ARROW
T2	WHITE SOLID LANE LINE	↷	T71 RIGHT TURN ARROW
T5	2 FT. - 6 FT./SP WHITE MINI-SKIP	↑	T72 STRAIGHT ARROW
T13	YELLOW DOUBLE CENTER	↙	T73 LEFT/STRAIGHT ARROW
<b>THERMOPLASTIC (6", 90 MIL)</b>		↘	T74 RIGHT/STRAIGHT ARROW
T20	WHITE EDGE LINE	↘	T79 MERGE ARROW
T21	WHITE SOLID LANE LINE	▼▼▼	T103 YIELD LINE TRIANGLE
T22	10 FT. WHITE SKIP	<b>SNOWPLOWABLE PAVEMENT MARKERS</b>	
T23	3 FT. - 9 FT./SP WHITE MINI-SKIP	ME	YELLOW/YELLOW
T24	2 FT. - 6 FT./SP WHITE MINI-SKIP	MF	CRYSTAL RED
T30	YELLOW EDGE LINE		
T33	YELLOW DOUBLE CENTER		
<b>THERMOPLASTIC (12", 90 MIL)</b>			
T50	WHITE GORE LINE		
T52	YELLOW DIAGONAL		
<b>THERMOPLASTIC (24", 90 MIL)</b>			
T61	WHITE STOP BAR		
T62	WHITE CROSSWALK LINE		

ALL LANE WIDTHS 12' UNLESS OTHERWISE NOTED.  
TRANSITION FROM 6" MARKINGS TO 4" MARKINGS  
AT THE MIDPOINT OF THE RADIUS OR STOP BAR  
AS APPLICABLE AT INTERSECTIONS.

**PAVEMENT MARKING DETAIL**

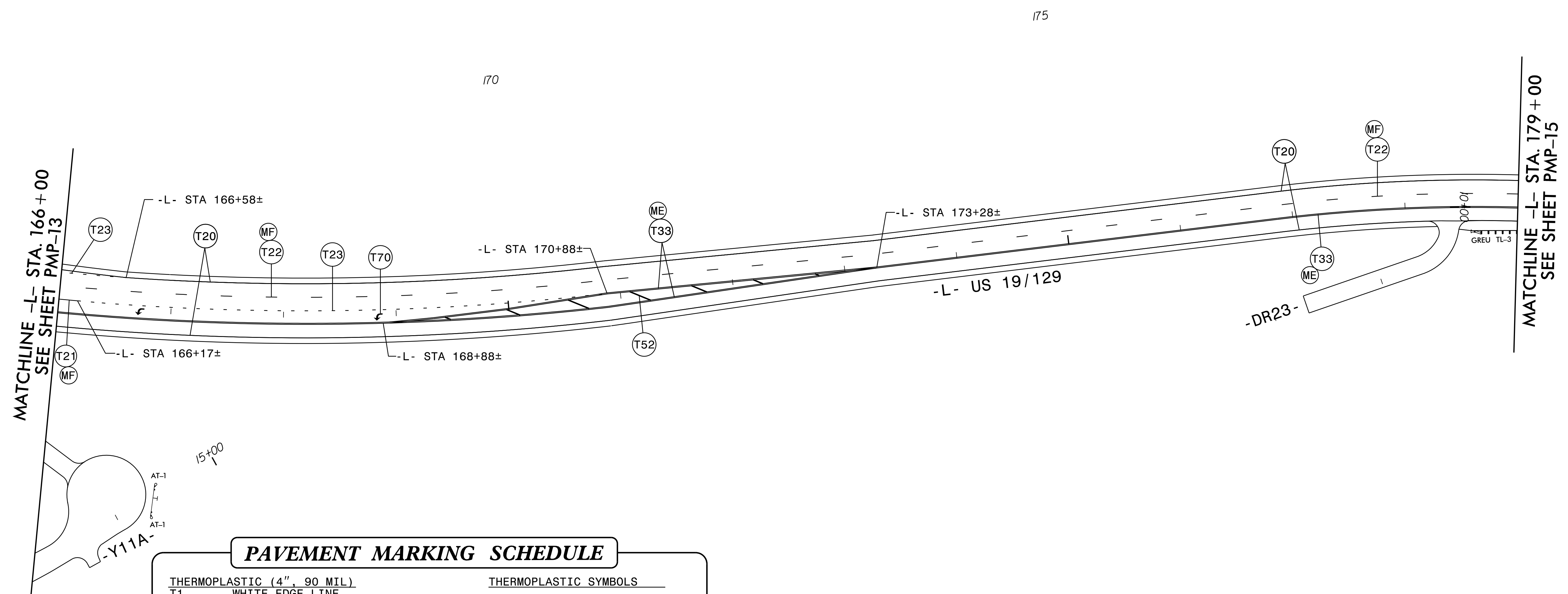

**PAVEMENT MARKING SCHEDULE**

<b>THERMOPLASTIC (4", 90 MIL)</b>		<b>THERMOPLASTIC SYMBOLS</b>	
T1	WHITE EDGE LINE	↶	T70 LEFT TURN ARROW
T2	WHITE SOLID LANE LINE	↷	T71 RIGHT TURN ARROW
T5	2 FT. - 6 FT./SP WHITE MINI-SKIP	↑	T72 STRAIGHT ARROW
T13	YELLOW DOUBLE CENTER	↙↘	T73 LEFT/STRAIGHT ARROW
<b>THERMOPLASTIC (6", 90 MIL)</b>		↘↙	T74 RIGHT/STRAIGHT ARROW
T20	WHITE EDGE LINE	↘	T79 MERGE ARROW
T21	WHITE SOLID LANE LINE	▼▼▼	T103 YIELD LINE TRIANGLE
T22	10 FT. WHITE SKIP	<b>SNOWPLOWABLE PAVEMENT MARKERS</b>	
T23	3 FT. - 9 FT./SP WHITE MINI-SKIP	ME	YELLOW/YELLOW
T24	2 FT. - 6 FT./SP WHITE MINI-SKIP	MF	CRYSTAL RED
T30	YELLOW EDGE LINE		
T33	YELLOW DOUBLE CENTER		
<b>THERMOPLASTIC (12", 90 MIL)</b>			
T50	WHITE GORE LINE		
T52	YELLOW DIAGONAL		
<b>THERMOPLASTIC (24", 90 MIL)</b>			
T61	WHITE STOP BAR		
T62	WHITE CROSSWALK LINE		

ALL LANE WIDTHS 12' UNLESS OTHERWISE NOTED.  
TRANSITION FROM 6" MARKINGS TO 4" MARKINGS  
AT THE MIDPOINT OF THE RADIUS OR STOP BAR  
AS APPLICABLE AT INTERSECTIONS.

**PAVEMENT MARKING DETAIL**

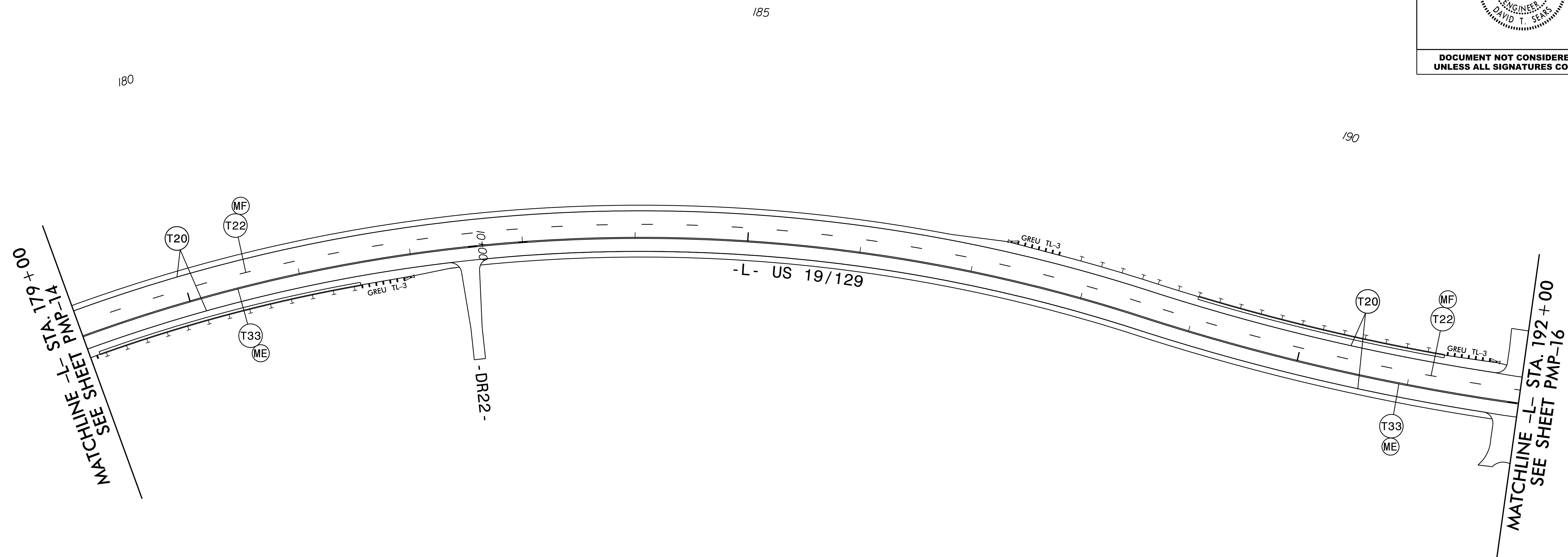
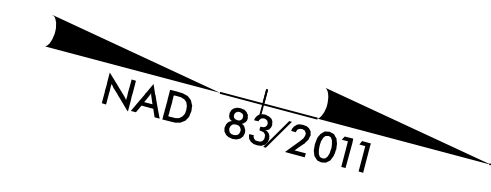

**PAVEMENT MARKING SCHEDULE**

<b>THERMOPLASTIC (4", 90 MIL)</b>		<b>THERMOPLASTIC SYMBOLS</b>	
T1	WHITE EDGE LINE	↶	T70 LEFT TURN ARROW
T2	WHITE SOLID LANE LINE	↷	T71 RIGHT TURN ARROW
T5	2 FT. - 6 FT./SP WHITE MINI-SKIP	↑	T72 STRAIGHT ARROW
T13	YELLOW DOUBLE CENTER	↙	T73 LEFT/STRAIGHT ARROW
<b>THERMOPLASTIC (6", 90 MIL)</b>		↘	T74 RIGHT/STRAIGHT ARROW
T20	WHITE EDGE LINE	↘	T79 MERGE ARROW
T21	WHITE SOLID LANE LINE	▼▼▼▼	T103 YIELD LINE TRIANGLE
T22	10 FT. WHITE SKIP		
T23	3 FT. - 9 FT./SP WHITE MINI-SKIP		
T24	2 FT. - 6 FT./SP WHITE MINI-SKIP		
T30	YELLOW EDGE LINE		
T33	YELLOW DOUBLE CENTER		
<b>THERMOPLASTIC (12", 90 MIL)</b>		<b>SNOWPLOWABLE PAVEMENT MARKERS</b>	
T50	WHITE GORE LINE	ME	YELLOW/YELLOW
T52	YELLOW DIAGONAL	MF	CRYSTAL RED
<b>THERMOPLASTIC (24", 90 MIL)</b>			
T61	WHITE STOP BAR		
T62	WHITE CROSSWALK LINE		

ALL LANE WIDTHS 12' UNLESS OTHERWISE NOTED.  
TRANSITION FROM 6" MARKINGS TO 4" MARKINGS AT THE MIDPOINT OF THE RADIUS OR STOP BAR AS APPLICABLE AT INTERSECTIONS.

**PAVEMENT MARKING DETAIL**



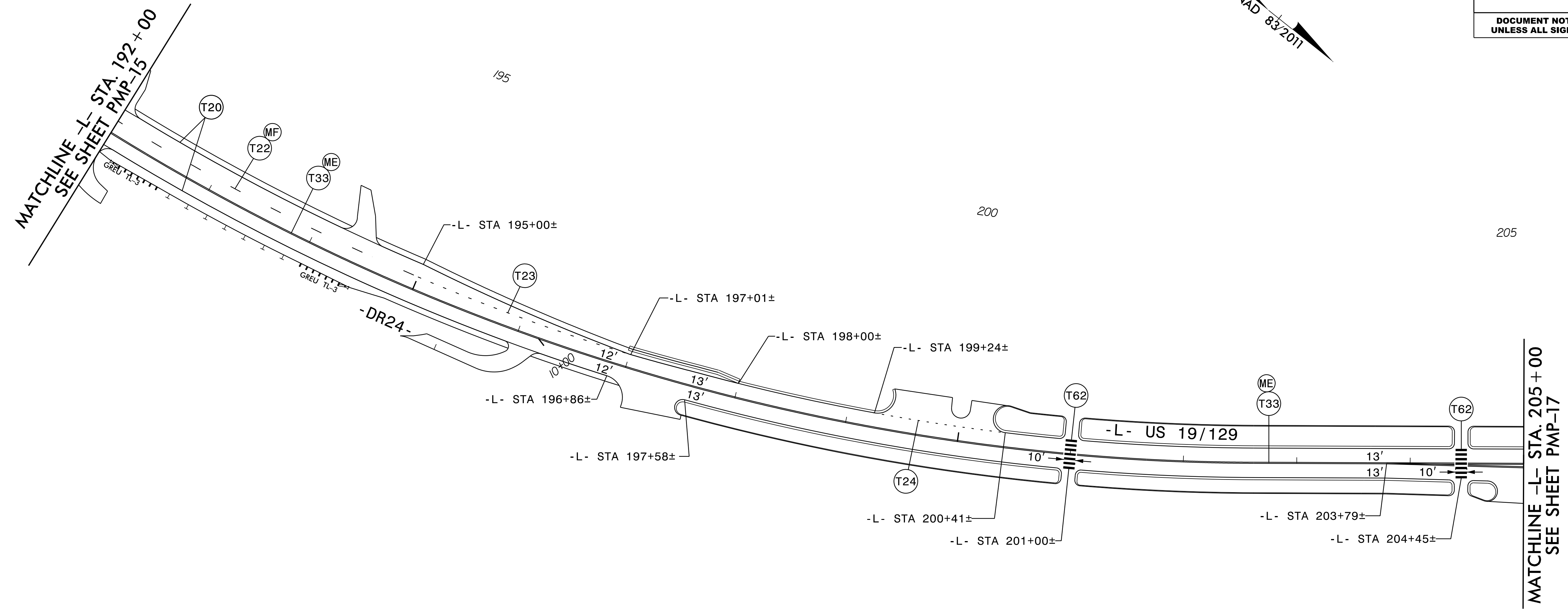

**PAVEMENT MARKING SCHEDULE**

<b>THERMOPLASTIC (4", 90 MIL)</b>		<b>THERMOPLASTIC SYMBOLS</b>	
T1	WHITE EDGE LINE	↶	T70 LEFT TURN ARROW
T2	WHITE SOLID LANE LINE	↷	T71 RIGHT TURN ARROW
T5	2 FT. - 6 FT./SP WHITE MINI-SKIP	↑	T72 STRAIGHT ARROW
T13	YELLOW DOUBLE CENTER	↙	T73 LEFT/STRAIGHT ARROW
<b>THERMOPLASTIC (6", 90 MIL)</b>		↘	T74 RIGHT/STRAIGHT ARROW
T20	WHITE EDGE LINE	↘	T79 MERGE ARROW
T21	WHITE SOLID LANE LINE	▼▼▼	T103 YIELD LINE TRIANGLE
T22	10 FT. WHITE SKIP		
T23	3 FT. - 9 FT./SP WHITE MINI-SKIP		
T24	2 FT. - 6 FT./SP WHITE MINI-SKIP		
T30	YELLOW EDGE LINE		
T33	YELLOW DOUBLE CENTER		
<b>THERMOPLASTIC (12", 90 MIL)</b>		<b>SNOWPLOWABLE PAVEMENT MARKERS</b>	
T50	WHITE GORE LINE	ME	YELLOW/YELLOW
T52	YELLOW DIAGONAL	MF	CRYSTAL RED
<b>THERMOPLASTIC (24", 90 MIL)</b>			
T61	WHITE STOP BAR		
T62	WHITE CROSSWALK LINE		

ALL LANE WIDTHS 12' UNLESS OTHERWISE NOTED.  
TRANSITION FROM 6" MARKINGS TO 4" MARKINGS AT THE MIDPOINT OF THE RADIUS OR STOP BAR AS APPLICABLE AT INTERSECTIONS.

PAVEMENT MARKING DETAIL



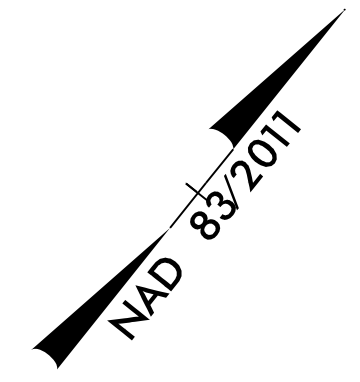

35

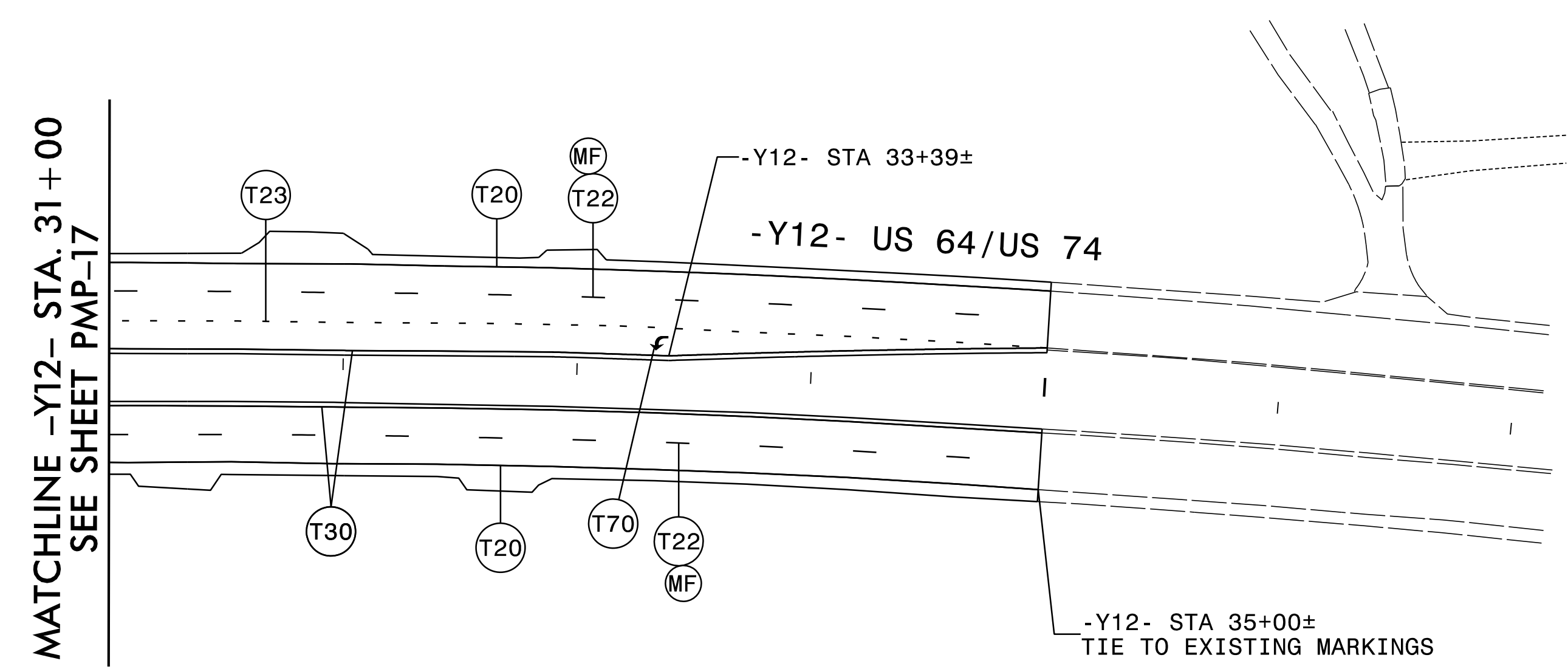

**PAVEMENT MARKING SCHEDULE**

<b>THERMOPLASTIC (4", 90 MIL)</b>		<b>THERMOPLASTIC SYMBOLS</b>	
T1	WHITE EDGE LINE	↶	T70 LEFT TURN ARROW
T2	WHITE SOLID LANE LINE	↷	T71 RIGHT TURN ARROW
T5	2 FT. - 6 FT./SP WHITE MINI-SKIP	↑	T72 STRAIGHT ARROW
T13	YELLOW DOUBLE CENTER	↙↘	T73 LEFT/STRAIGHT ARROW
<b>THERMOPLASTIC (6", 90 MIL)</b>		↘↙	T74 RIGHT/STRAIGHT ARROW
T20	WHITE EDGE LINE	↘	T79 MERGE ARROW
T21	WHITE SOLID LANE LINE	▼▼▼	T103 YIELD LINE TRIANGLE
T22	10 FT. WHITE SKIP		
T23	3 FT. - 9 FT./SP WHITE MINI-SKIP		
T24	2 FT. - 6 FT./SP WHITE MINI-SKIP		
T30	YELLOW EDGE LINE		
T33	YELLOW DOUBLE CENTER		
<b>THERMOPLASTIC (12", 90 MIL)</b>		<b>SNOWPLOWABLE PAVEMENT MARKERS</b>	
T50	WHITE GORE LINE	ME	YELLOW/YELLOW
T52	YELLOW DIAGONAL	MF	CRYSTAL RED
<b>THERMOPLASTIC (24", 90 MIL)</b>			
T61	WHITE STOP BAR		
T62	WHITE CROSSWALK LINE		

ALL LANE WIDTHS 12' UNLESS OTHERWISE NOTED.  
TRANSITION FROM 6" MARKINGS TO 4" MARKINGS  
AT THE MIDPOINT OF THE RADIUS OR STOP BAR  
AS APPLICABLE AT INTERSECTIONS.

PAVEMENT MARKING DETAIL

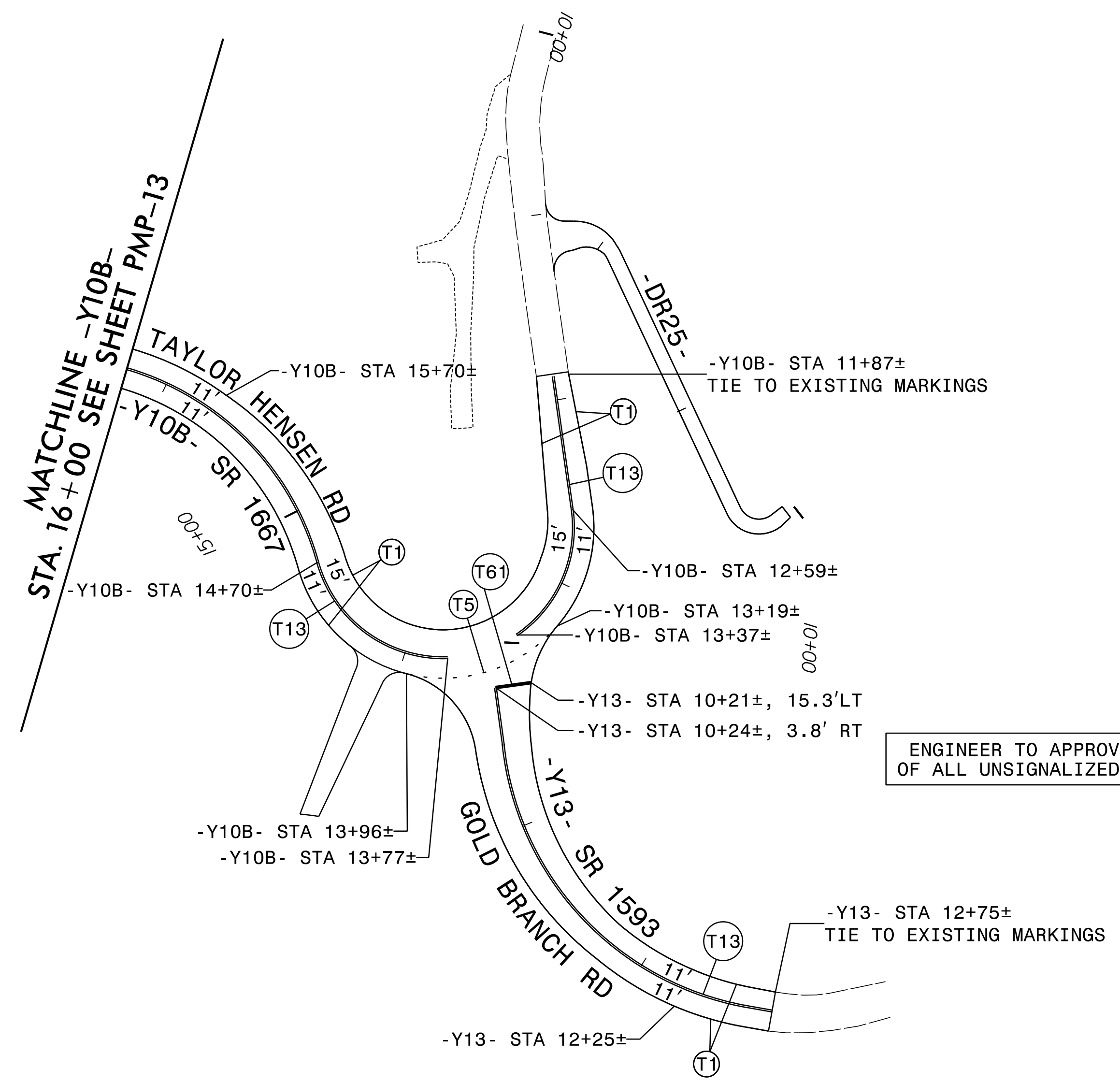
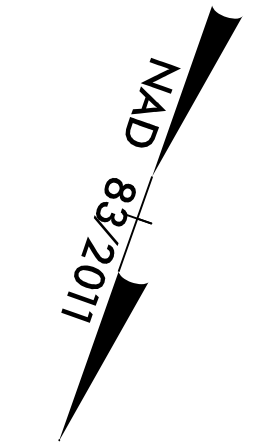

### PAVEMENT MARKING SCHEDULE

<b>THERMOPLASTIC (4", 90 MIL)</b>		<b>THERMOPLASTIC SYMBOLS</b>	
T1	WHITE EDGE LINE	↶	T70 LEFT TURN ARROW
T2	WHITE SOLID LANE LINE	↷	T71 RIGHT TURN ARROW
T5	2 FT. - 6 FT./SP WHITE MINI-SKIP	↑	T72 STRAIGHT ARROW
T13	YELLOW DOUBLE CENTER	↵	T73 LEFT/STRAIGHT ARROW
<b>THERMOPLASTIC (6", 90 MIL)</b>		↷	T74 RIGHT/STRAIGHT ARROW
T20	WHITE EDGE LINE	↘	T79 MERGE ARROW
T21	WHITE SOLID LANE LINE	▼▼▼▼	T103 YIELD LINE TRIANGLE
T22	10 FT. WHITE SKIP		
T23	3 FT. - 9 FT./SP WHITE MINI-SKIP		
T24	2 FT. - 6 FT./SP WHITE MINI-SKIP		
T30	YELLOW EDGE LINE		
T33	YELLOW DOUBLE CENTER		
<b>THERMOPLASTIC (12", 90 MIL)</b>		<b>SNOWPLOWABLE PAVEMENT MARKERS</b>	
T50	WHITE GORE LINE	ME	YELLOW/YELLOW
T52	YELLOW DIAGONAL	MF	CRYSTAL RED
<b>THERMOPLASTIC (24", 90 MIL)</b>			
T61	WHITE STOP BAR		
T62	WHITE CROSSWALK LINE		

ALL LANE WIDTHS 12' UNLESS OTHERWISE NOTED.  
TRANSITION FROM 6" MARKINGS TO 4" MARKINGS  
AT THE MIDPOINT OF THE RADIUS OR STOP BAR  
AS APPLICABLE AT INTERSECTIONS.

### PAVEMENT MARKING DETAIL