

PROJECT REFERENCE NO. U-5312	SHEET NO. W-1
RW SHEET NO.	
GEOTECHNICAL ENGINEER	HYDRAULICS ENGINEER
DOCUMENT NOT CONSIDERED FINAL UNLESS ALL SIGNATURES COMPLETED	

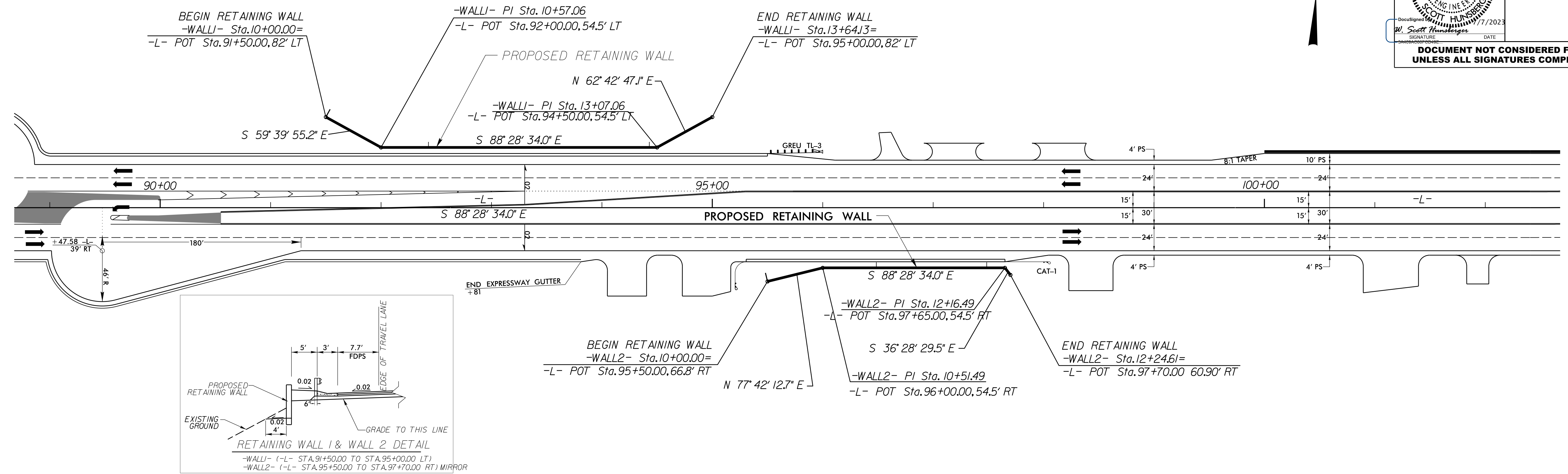

RETAINING WALL ENVELOPES

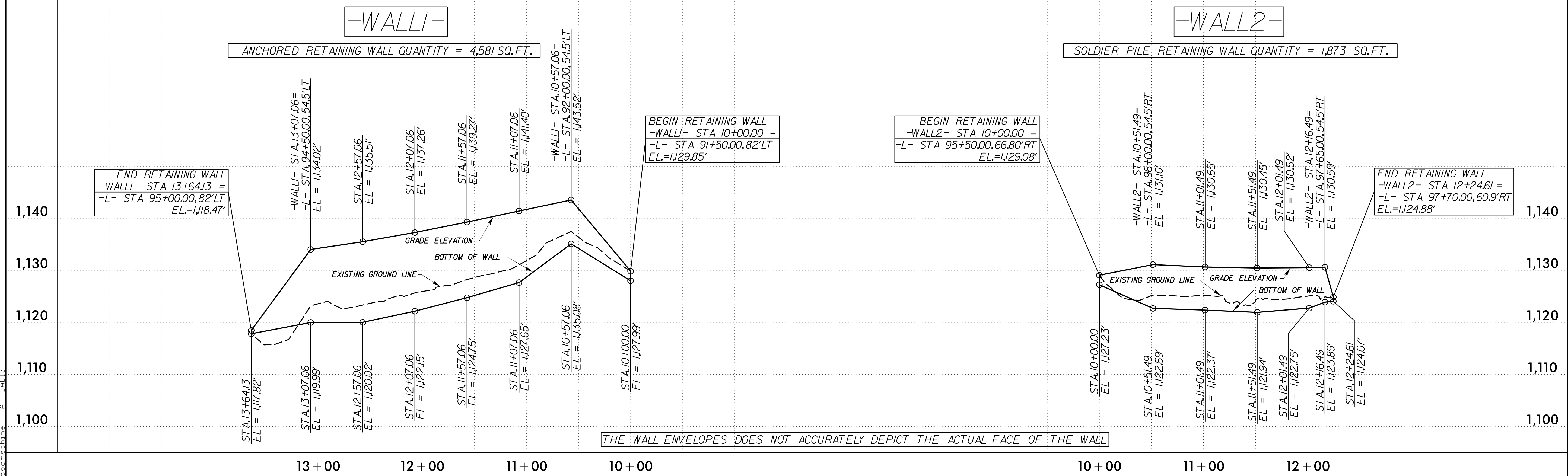

7- JUL - 2023 08:55
 T:\Projects\2023\17038.00_VHB_U-5312 (US-421) Superstreet in Wilkes County\U5312.GEO_ROWY\CADD.GEOTECH\Site&Sub\U5312.GEO_RetainingWall.dgn
 8/17/23

8/17/23
 7- JUL-2023 08:55
 T:\Projects\2023\17038.00 VHB U-5312 (US-421) Superstreet in Wilkes County\U5312.GEO_RDWY\CADD_GEO\TECH\Site&Sub\U5312.GEO_RetainingWall.dgn
 cadimur
 AT CAD13

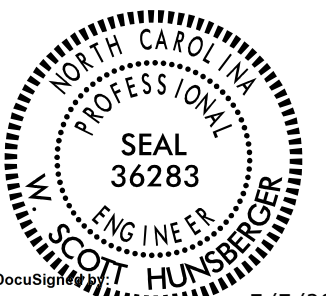
PROJECT REFERENCE NO. U-5312	SHEET NO. W-2
RW SHEET NO.	
GEOTECHNICAL ENGINEER  W. Scott Hunsberger SIGNATURE DATE 7/7/2023	
DOCUMENT NOT CONSIDERED FINAL UNLESS ALL SIGNATURES COMPLETED	

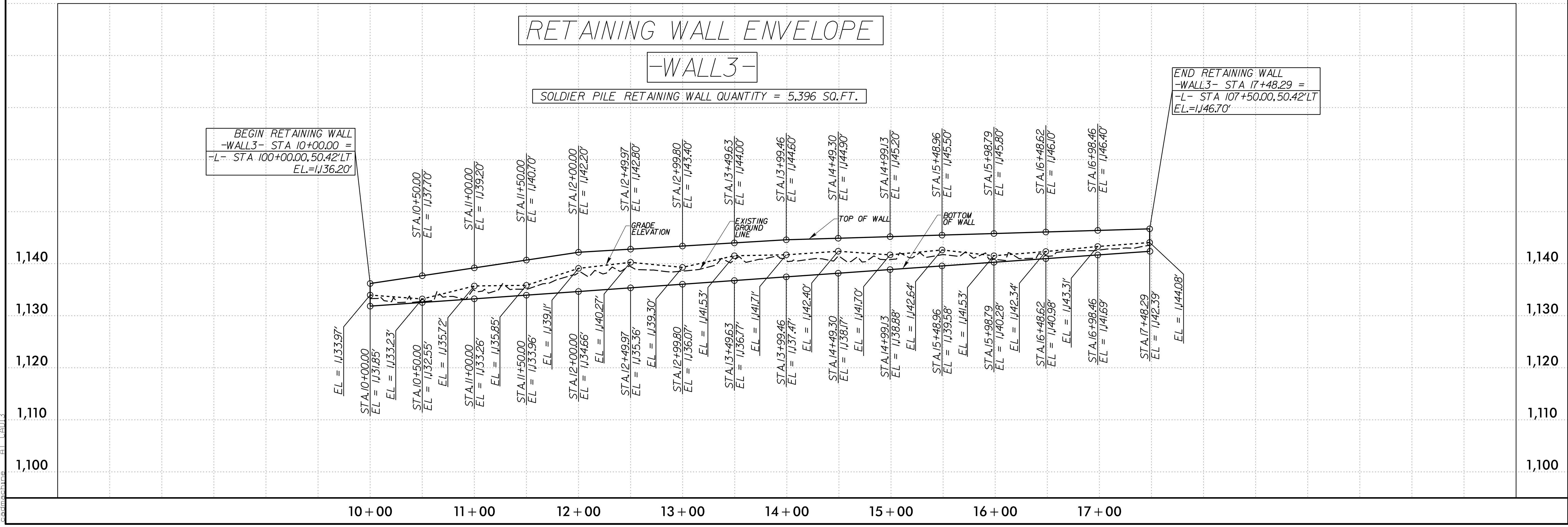
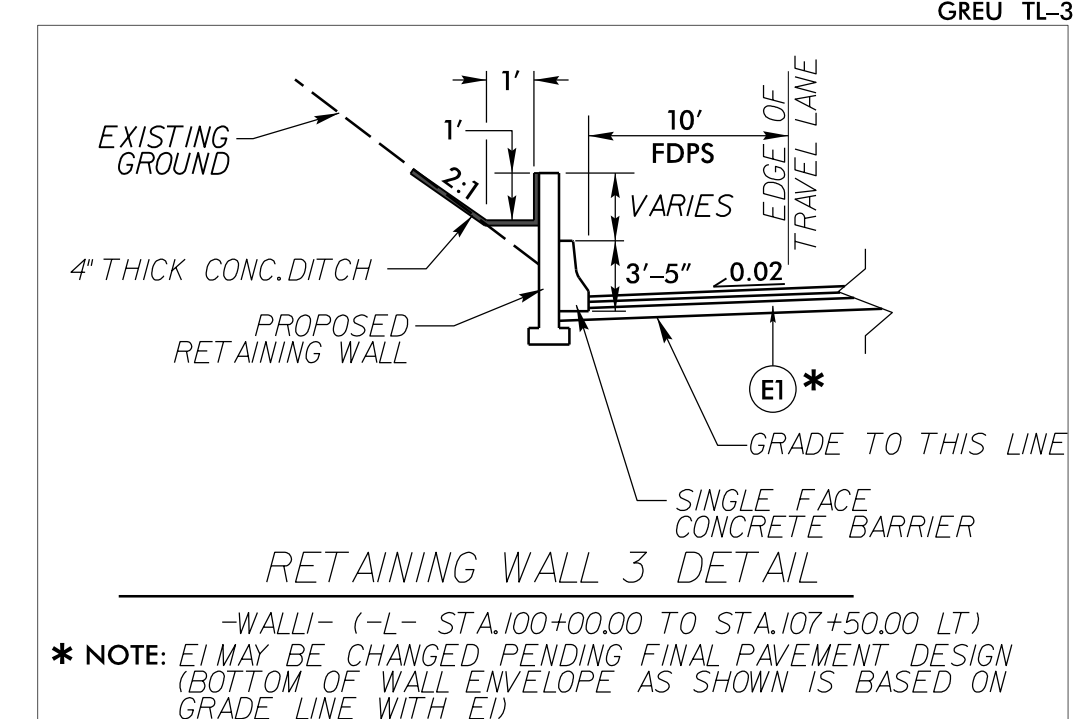
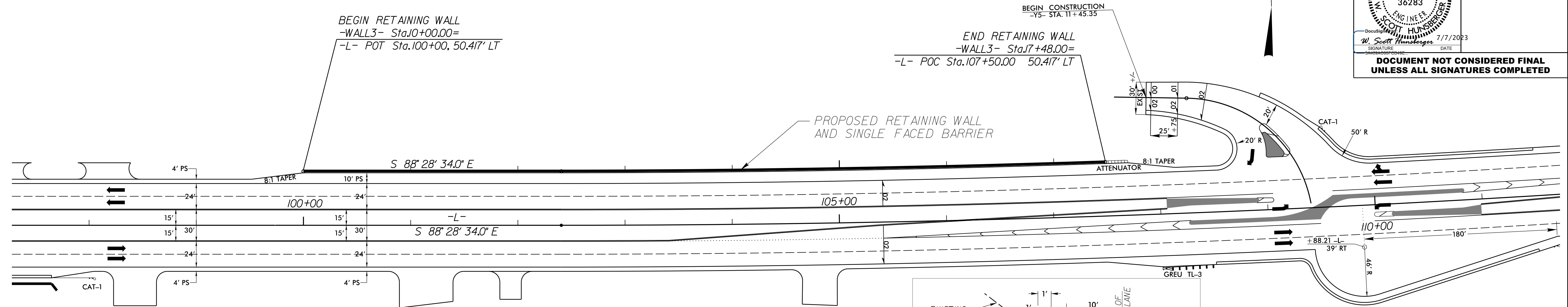

GEOTECHNICAL ENGINEER

W. Scott Hunsberger
7/7/2023

ENGINEER

DATE: _____

DOCUMENT NOT CONSIDERED FINAL
UNLESS ALL SIGNATURES COMPLETED

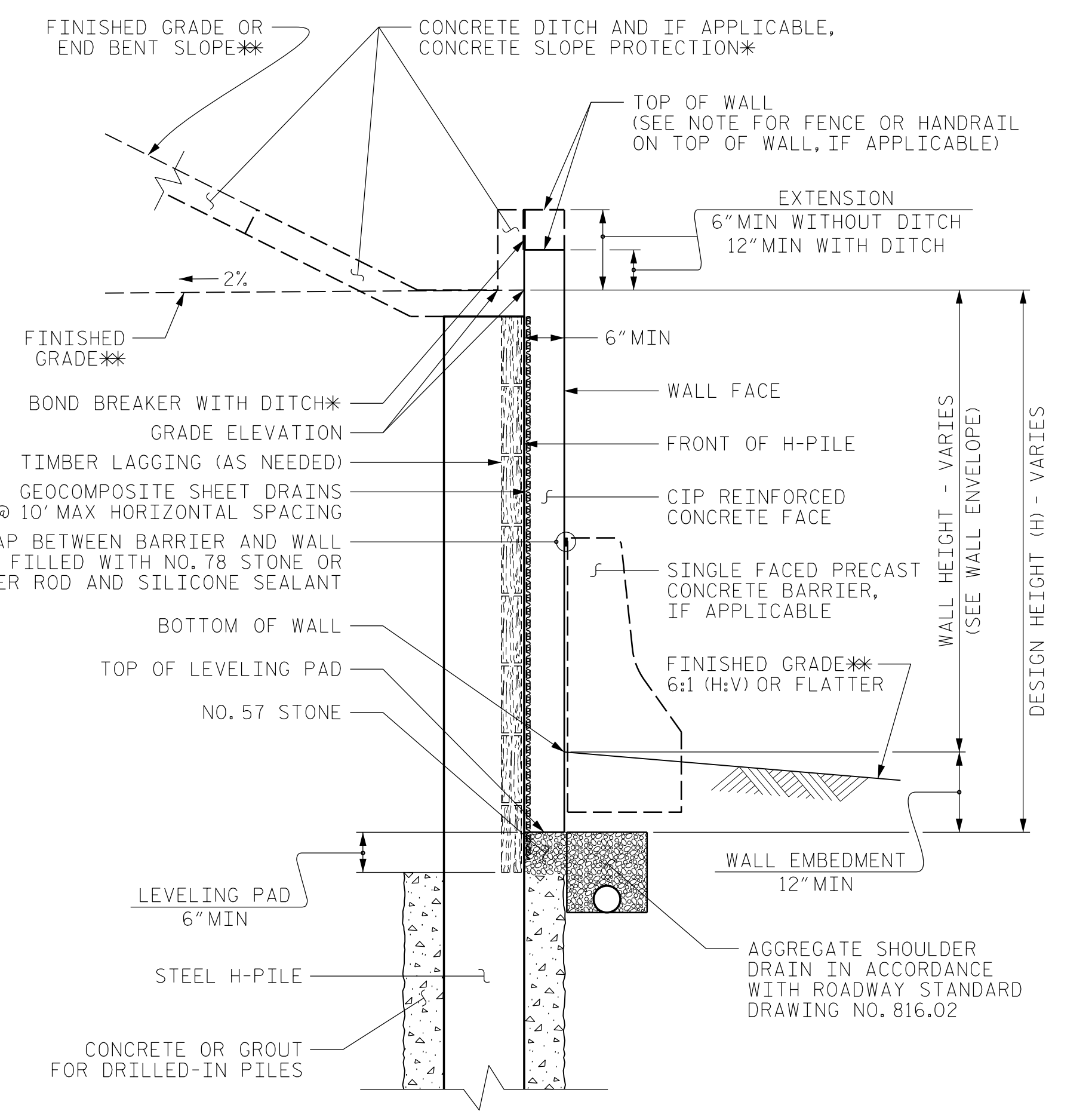
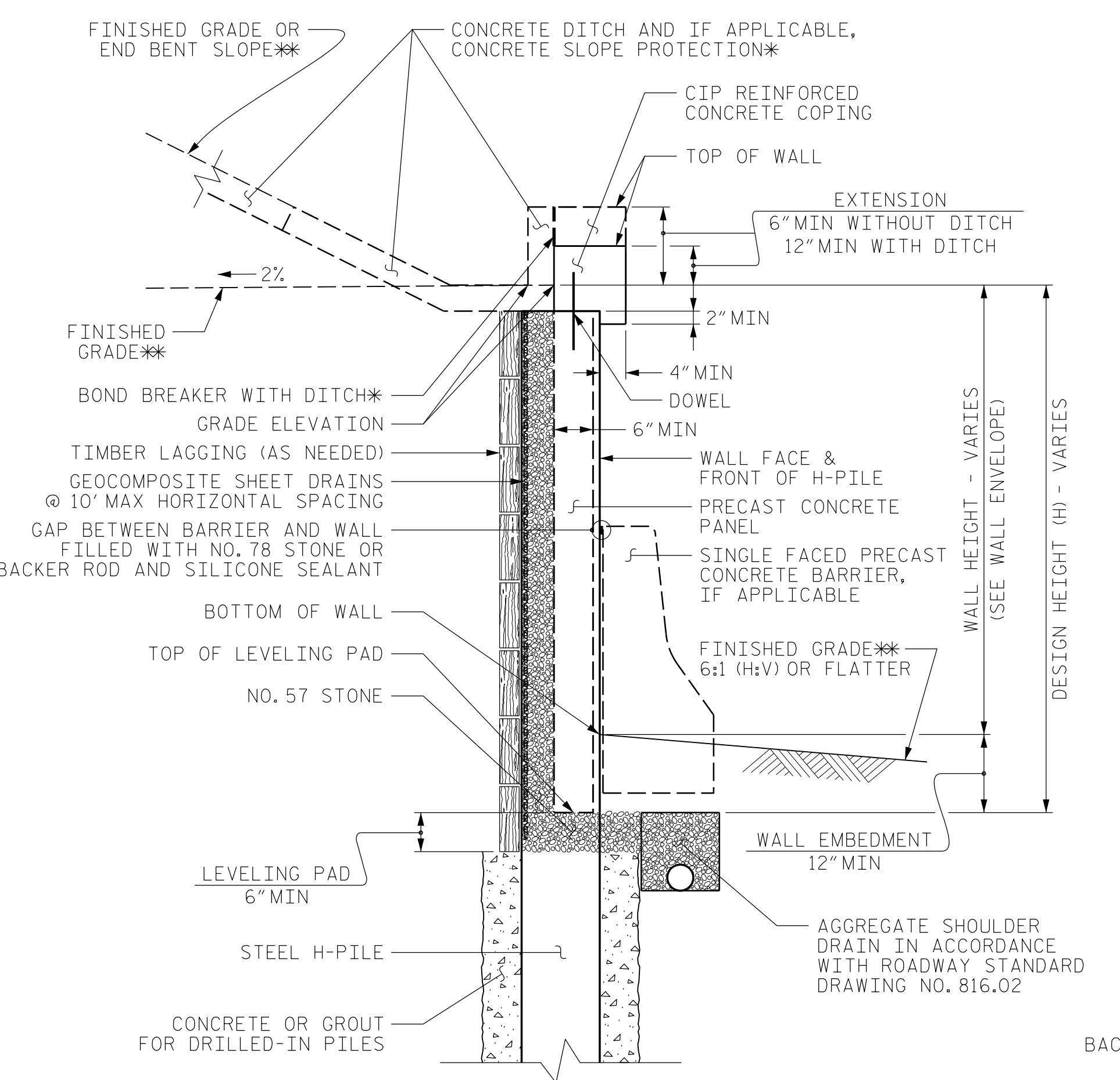
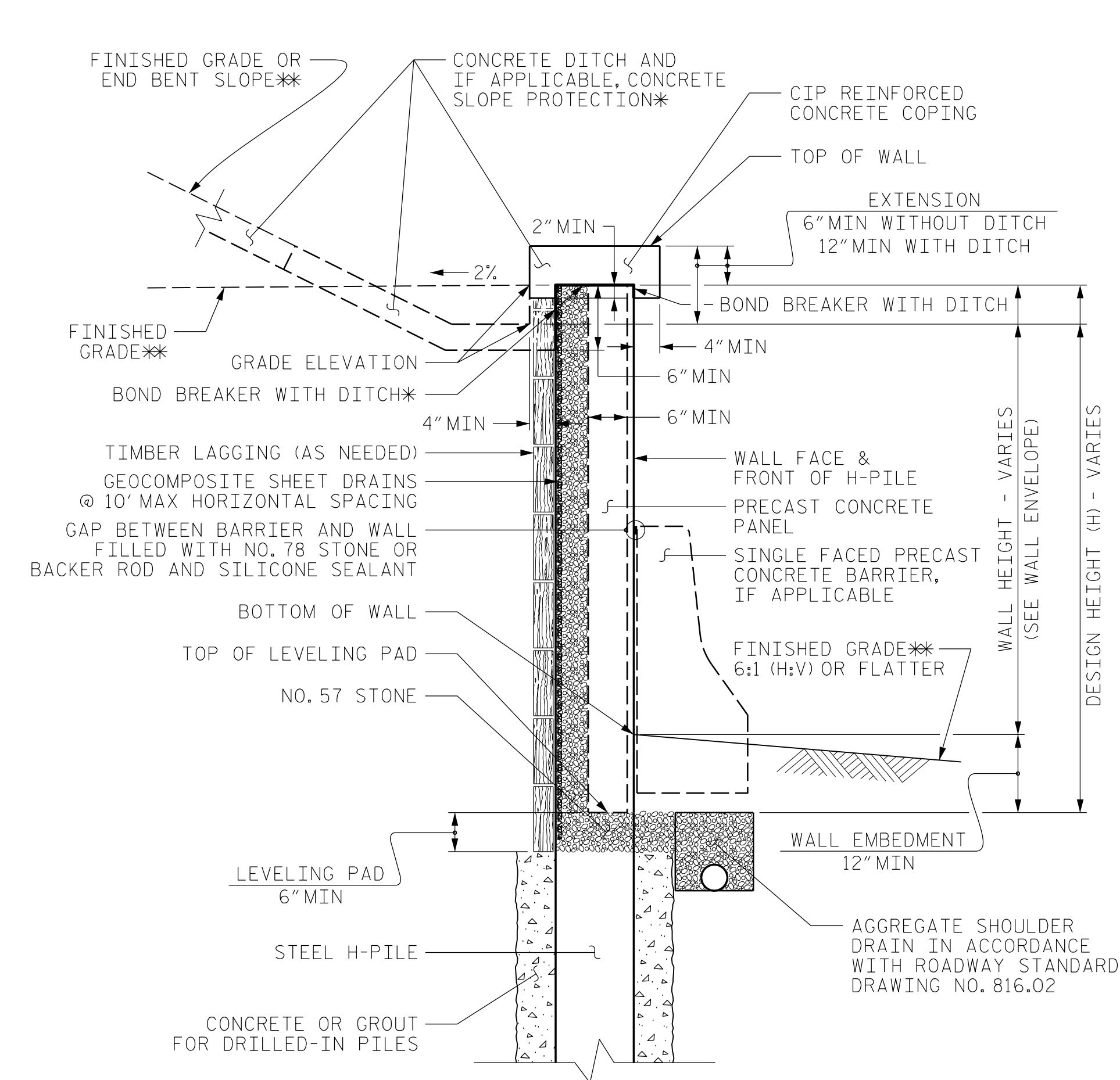

SOLDIER PILE WALL WITH PRECAST PANEL - TYPICAL SECTIONS

AT THE CONTRACTOR'S OPTION, CONNECT COPING TO PANELS WITH DOWELS OR EXTEND COPING DOWN BACK OF PANELS AND PILES.
*SEE CONCRETE DITCH BEHIND WALL DETAILS.
**SEE PLANS FOR FINISHED GRADE OR END BENT SLOPE DETAILS.

NOTES:

- FOR SOLDIER PILE RETAINING WALLS, SEE SOLDIER PILE RETAINING WALLS PROVISION.
- FOR ANCHORED RETAINING WALLS, SEE ANCHORED RETAINING WALLS PROVISION.
- FOR STEEL BEAM GUARDRAIL, SEE ROADWAY PLANS AND SECTION 862 OF THE STANDARD SPECIFICATIONS.
- FOR SINGLE FACED PRECAST CONCRETE BARRIER, SEE ROADWAY PLANS AND SECTION 857 OF THE STANDARD SPECIFICATIONS.
- DRILLED-IN H-PILES ARE REQUIRED FOR RETAINING WALL NO. 1.
- AT THE CONTRACTOR'S OPTION, USE DRIVEN H-PILES FOR RETAINING WALLS NO. 2 AND 3.
- BEFORE BEGINNING WALL DESIGN FOR RETAINING WALL NO. 1, 2 & 3, SURVEY WALL LOCATION AND SUBMIT A REVISED WALL PROFILE VIEW (WALL ENVELOPE) FOR REVIEW. DO NOT START WALL DESIGN OR CONSTRUCTION UNTIL THE REVISED WALL ENVELOPE IS ACCEPTED.
- DESIGN RETAINING WALLS NO. 1 AS ANCHORED RETAINING WALL.
- DESIGN RETAINING WALLS NO. 2 AND 3 AS SOLDIER PILE RETAINING WALLS.
- DESIGN RETAINING WALLS NO. 1 AND 2 FOR A LIVE LOAD (TRAFFIC) SURCHARGE.
- AT THE CONTRACTOR'S OPTION, USE A TEMPORARY SLOPE INSTEAD OF TEMPORARY SUPPORT OF EXCAVATIONS FOR RETAINING WALLS NO. 1, 2 AND 3.

"TEMPORARY SHORING" MAY BE REQUIRED FOR RETAINING WALLS NO. 1 AND 2 IN ACCORDANCE WITH THE TEMPORARY SHORING PROVISION. SEE TRAFFIC CONTROL PLANS.

WALL 1 - 10+00 to 11+25				
DEPTH BELOW TOP OF WALL	UNIT WEIGHT, γ (PCF)	FRICTION ANGLE, ϕ	COHESION, c	ROCK MASS SHEAR STRENGTH SM (PSF)
0' TO 14'	120	30	0	-
14' TO 29'	130	34	0	-
29' +	-	-	-	3,000

WALL 1 - 11+25 to 12+25				
DEPTH BELOW TOP OF WALL	UNIT WEIGHT, γ (PCF)	FRICTION ANGLE, ϕ	COHESION, c	ROCK MASS SHEAR STRENGTH SM (PSF)
0' TO 24'	120	30	0	-
24' TO 29'	130	34	0	-
29' +	-	-	-	3,000

WALL 1 - 12+25 to 13+64.13				
DEPTH BELOW TOP OF WALL	UNIT WEIGHT, γ (PCF)	FRICTION ANGLE, ϕ	COHESION, c	ROCK MASS SHEAR STRENGTH SM (PSF)
FULL DEPTH	120	30	0	-

WALL 2				
DEPTH BELOW TOP OF WALL	UNIT WEIGHT, γ (PCF)	FRICTION ANGLE, ϕ	COHESION, c	ROCK MASS SHEAR STRENGTH SM (PSF)
FULL DEPTH	120	30	0	-

WALL 3 - 10+00 to 11+50				
DEPTH BELOW TOP OF WALL	UNIT WEIGHT, γ (PCF)	FRICTION ANGLE, ϕ	COHESION, c	ROCK MASS SHEAR STRENGTH SM (PSF)
0' TO 7'	120	30	0	-
7' +	-	-	-	3,000

WALL 3 - 11+50 to 14+00				
DEPTH BELOW TOP OF WALL	UNIT WEIGHT, γ (PCF)	FRICTION ANGLE, ϕ	COHESION, c	ROCK MASS SHEAR STRENGTH SM (PSF)
FULL DEPTH	120	30	0	-

WALL 3 - 14+00 to 14+50				
DEPTH BELOW TOP OF WALL	UNIT WEIGHT, γ (PCF)	FRICTION ANGLE, ϕ	COHESION, c	ROCK MASS SHEAR STRENGTH SM (PSF)
0' TO 10'	120	30	0	-
10' +	-	-	-	3,000

WALL 3 - 14+50 to 17+48				
DEPTH BELOW TOP OF WALL	UNIT WEIGHT, γ (PCF)	FRICTION ANGLE, ϕ	COHESION, c	ROCK MASS SHEAR STRENGTH SM (PSF)
FULL DEPTH	120	30	0	-

SOLDIER PILE WALL WITH CIP FACE - TYPICAL SECTION

*SEE CONCRETE DITCH BEHIND WALL DETAILS.
**SEE PLANS FOR FINISHED GRADE OR END BENT SLOPE DETAILS.

PROJECT NO.: U-5312
 WILKES COUNTY
 STATION: SEE SHEET W-1 AND W-2
 SHEET 3 OF 4 WALL ID RW-1, 2 AND 3

STANDARD DETAIL NO. 816.02

SOLDIER PILE WALL
WITH OR WITHOUT
BACKSLOPES
TYPICALS AND NOTES

DATE: MM-DD-YY

FALCON ENGINEERING, INC.
1210 TRINITY ROAD, SUITE 110
CARY, NC 27513
PHONE: 919.871.0800
www.falconengineers.com

NORTH CAROLINA
DEPARTMENT OF TRANSPORTATION
DIVISION OF HIGHWAYS

GEOTECHNICAL
ENGINEERING UNIT

SHEET NO. W-3

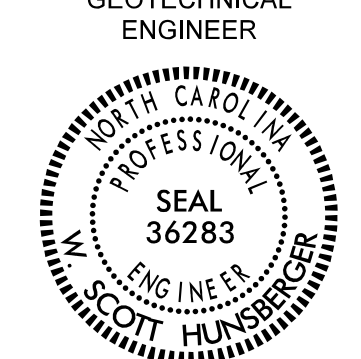
<p>GEOTECHNICAL ENGINEER</p>  <p>DocuSigned by: <i>W. Scott Hunsberger</i> 7/7/2023</p>	<p>ENGINEER</p> <p>DATE: _____ SIGNATURE: _____</p>
<p>DOCUMENT NOT CONSIDERED FINAL UNLESS ALL SIGNATURES COMPLETED</p>	

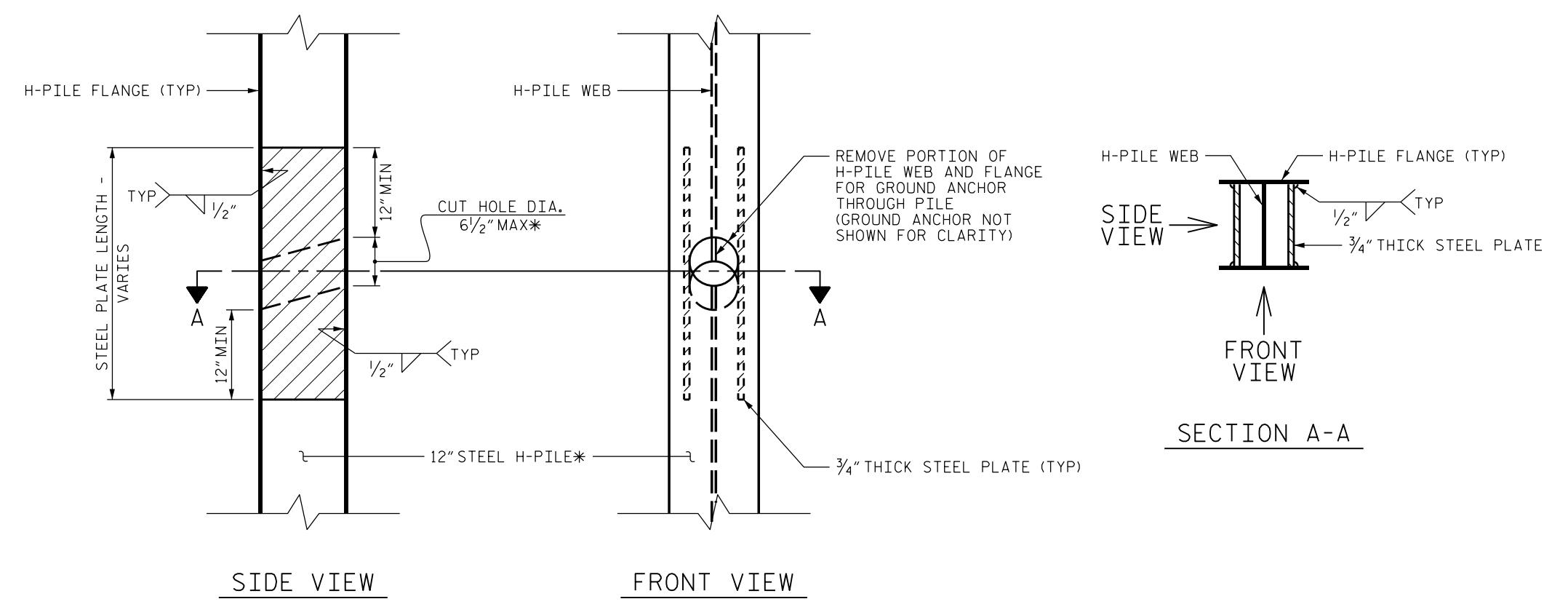
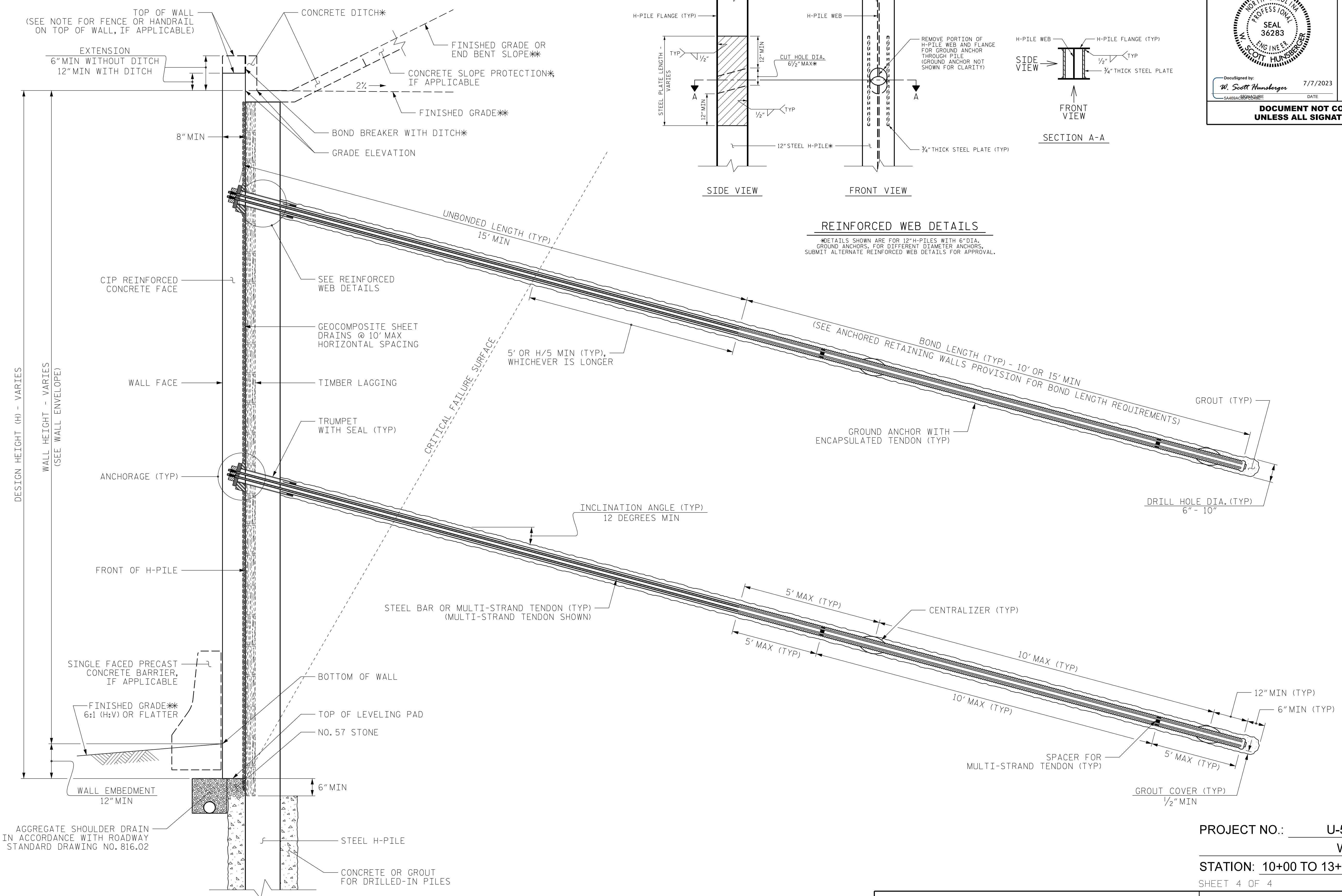

REINFORCED WEB DETAILS
 *DETAILS SHOWN ARE FOR 12\"/>

ANCHORED WALL - TYPICAL SECTION - WALL 1 ALTERNATE

(DOUBLE ROW OF GROUND ANCHORS SHOWN, AS NEEDED)
 *SEE CONCRETE DITCH BEHIND WALL DETAILS.
 **SEE PLANS FOR FINISHED GRADE OR END BENT SLOPE DETAILS.



FALCON ENGINEERING, INC.
 1210 TRINITY ROAD, SUITE 110
 CARY, NC 27513
 PHONE: 919.871.0800
 www.falconengineers.com

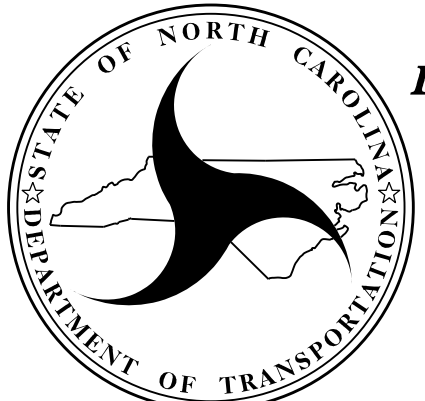

**NORTH CAROLINA
 DEPARTMENT OF TRANSPORTATION
 DIVISION OF HIGHWAYS**

**GEOTECHNICAL
 ENGINEERING UNIT**

PROJECT NO.: U-5312
 WILKES COUNTY
 STATION: 10+00 TO 13+64.13
 SHEET 4 OF 4 WALL ID RW-1

ANCHORED WALL

**ANCHORED WALL
 WITH OR WITHOUT
 BACKSLOPES-
 TYPICAL**

DATE: MM-DD-YY