









PROJECT REFERENCE NO. <b>R-5799</b>	SHEET NO. <b>UC-8A</b>
DESIGNED BY: <b>MRD</b>	
DRAWN BY: <b>SRW</b>	
CHECKED BY: <b>JDN</b>	
APPROVED BY: <b>JDN</b>	NORTH CAROLINA DEPARTMENT OF TRANSPORTATION UTILITIES ENGINEERING SEC. PHONE: (919) 707-6690 FAX: (919) 250-4151
UTILITY CONSTRUCTION PLANS ONLY	

UTILITY CONSTRUCTION

DOCUMENT NOT CONSIDERED FINAL UNLESS ALL SIGNATURES COMPLETED

MAD 8/31/2011

REVISIONS

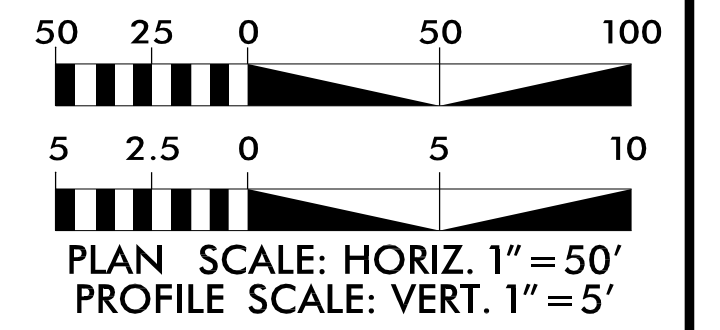
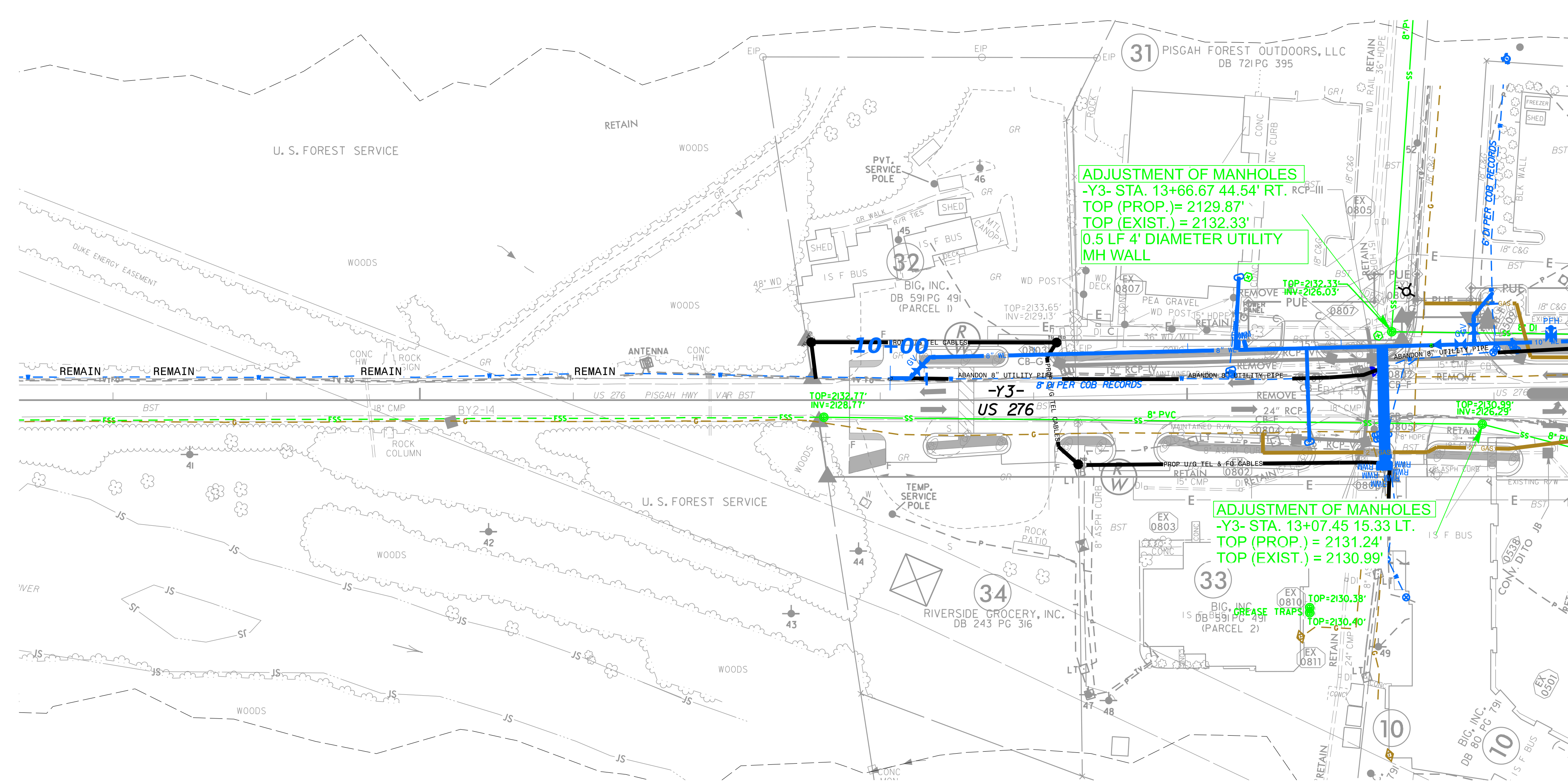

**V&M**  
 Vaughn & Melton  
 Consulting Engineers

Asheville, North Carolina 828-253-2196

Tri-Cities, TN 423-467-5900  
 Knoxville, TN 865-546-5800  
 Spartanburg, SC 864-574-4775  
 Charleston, SC 843-974-5650  
 Middleboro, KY 502-248-6600  
 Charlotte, NC 704-357-0488  
 Boone, NC 828-355-9933  
 Atlanta, GA 770-627-3509

Copyright © 2009 Vaughn & Melton, Inc. All Rights Reserved

MATCHLINE -Y3- STA. 12 + 46 SEE SHEET UC-5

4/28/20