

STATE OF NORTH CAROLINA
DEPARTMENT OF TRANSPORTATION
RALEIGH, N.C.

PROPOSAL

DATE AND TIME OF BID OPENING: **Nov 21, 2023 AT 02:00 PM**

CONTRACT ID C204904
WBS 44984.3.1

FEDERAL-AID NO. STATE FUNDED
COUNTY TRANSYLVANIA
T.I.P NO. R-5799
MILES 0.461
ROUTE NO. US-64
LOCATION INTERSECTIONS OF US-64 / US-276 (HENDERSONVILLE HWY), AND US-64 / NC-280 (ASHEVILLE HWY).

TYPE OF WORK GRADING, DRAINAGE, PAVING, SIGNALS, AND CULVERT.

NOTICE:

ALL BIDDERS SHALL COMPLY WITH ALL APPLICABLE LAWS REGULATING THE PRACTICE OF GENERAL CONTRACTING AS CONTAINED IN CHAPTER 87 OF THE GENERAL STATUTES OF NORTH CAROLINA WHICH REQUIRES THE BIDDER TO BE LICENSED BY THE N.C. LICENSING BOARD FOR CONTRACTORS WHEN BIDDING ON ANY NON-FEDERAL AID PROJECT WHERE THE BID IS \$30,000 OR MORE, EXCEPT FOR CERTAIN SPECIALTY WORK AS DETERMINED BY THE LICENSING BOARD. BIDDERS SHALL ALSO COMPLY WITH ALL OTHER APPLICABLE LAWS REGULATING THE PRACTICES OF ELECTRICAL, PLUMBING, HEATING AND AIR CONDITIONING AND REFRIGERATION CONTRACTING AS CONTAINED IN CHAPTER 87 OF THE GENERAL STATUTES OF NORTH CAROLINA. NOTWITHSTANDING THESE LIMITATIONS ON BIDDING, THE BIDDER WHO IS AWARDED ANY FEDERAL - AID FUNDED PROJECT SHALL COMPLY WITH CHAPTER 87 OF THE GENERAL STATUTES OF NORTH CAROLINA FOR LICENSING REQUIREMENTS WITHIN 60 CALENDAR DAYS OF BID OPENING.

BIDS WILL BE RECEIVED AS SHOWN BELOW:

THIS IS A ROADWAY & CULVERT PROPOSAL

5% BID BOND OR BID DEPOSIT REQUIRED

**PROPOSAL FOR THE CONSTRUCTION OF
CONTRACT No. C204904 IN TRANSYLVANIA COUNTY, NORTH CAROLINA
DEPARTMENT OF TRANSPORTATION,
RALEIGH, NORTH CAROLINA**

The Bidder has carefully examined the location of the proposed work to be known as Contract No. **C204904** has carefully examined the plans and specifications, which are acknowledged to be part of the proposal, the special provisions, the proposal, the form of contract, and the forms of contract payment bond and contract performance bond; and thoroughly understands the stipulations, requirements and provisions. The undersigned bidder agrees to be bound upon his execution of the bid and subsequent award to him by the Board of Transportation in accordance with this proposal to provide the necessary contract payment bond and contract performance bond within fourteen days after the written notice of award is received by him. The undersigned Bidder further agrees to provide all necessary machinery, tools, labor, and other means of construction; and to do all the work and to furnish all materials, except as otherwise noted, necessary to perform and complete the said contract in accordance with *the 2018 Standard Specifications for Roads and Structures* by the dates(s) specified in the Project Special Provisions and in accordance with the requirements of the Engineer, and at the unit or lump sum prices, as the case may be, for the various items given on the sheets contained herein.

The Bidder shall provide and furnish all the materials, machinery, implements, appliances and tools, and perform the work and required labor to construct and complete State Highway Contract No. **C204904** in **Transylvania County**, for the unit or lump sum prices, as the case may be, bid by the Bidder in his bid and according to the proposal, plans, and specifications prepared by said Department, which proposal, plans, and specifications show the details covering this project, and hereby become a part of this contract.

The published volume entitled *North Carolina Department of Transportation, Raleigh, Standard Specifications for Roads and Structures, January 2018* with all amendments and supplements thereto, is by reference incorporated into and made a part of this contract; that, except as herein modified, all the construction and work included in this contract is to be done in accordance with the specifications contained in said volume, and amendments and supplements thereto, under the direction of the Engineer.

If the proposal is accepted and the award is made, the contract is valid only when signed either by the Contract Officer or such other person as may be designated by the Secretary to sign for the Department of Transportation. The conditions and provisions herein cannot be changed except over the signature of the said Contract Officer.

The quantities shown in the itemized proposal for the project are considered to be approximate only and are given as the basis for comparison of bids. The Department of Transportation may increase or decrease the quantity of any item or portion of the work as may be deemed necessary or expedient.

An increase or decrease in the quantity of an item will not be regarded as sufficient ground for an increase or decrease in the unit prices, nor in the time allowed for the completion of the work, except as provided for the contract.

Accompanying this bid is a bid bond secured by a corporate surety, or certified check payable to the order of the Department of Transportation, for five percent of the total bid price, which deposit is to be forfeited as liquidated damages in case this bid is accepted and the Bidder shall fail to provide the required payment and performance bonds with the Department of Transportation, under the condition of this proposal, within 14 calendar days after the written notice of award is received by him, as provided in the *Standard Specifications*; otherwise said deposit will be returned to the Bidder.



State Contract Officer

DocuSigned by:

Ronald Elton Davenport, Jr.

F81B6038A47A442...

10/18/2023

TABLE OF CONTENTS**COVER SHEET
PROPOSAL SHEET****PROJECT SPECIAL PROVISIONS**

CONTRACTOR PREQUALIFICATION:.....	G-1
INTERESTED PARTIES LIST:	G-2
LIABILITY INSURANCE:.....	G-3
CONTRACT TIME AND LIQUIDATED DAMAGES:	G-3
INTERMEDIATE CONTRACT TIME NUMBER 1 AND LIQUIDATED DAMAGES:	G-4
INTERMEDIATE CONTRACT TIME NUMBER 2 AND LIQUIDATED DAMAGES:	G-4
INTERMEDIATE CONTRACT TIME NUMBER 3 AND LIQUIDATED DAMAGES:	G-6
INTERMEDIATE CONTRACT TIME NUMBER 4 AND LIQUIDATED DAMAGES:	G-7
INTERMEDIATE CONTRACT TIME NUMBER 5 AND LIQUIDATED DAMAGES:	G-7
PERMANENT VEGETATION ESTABLISHMENT:.....	G-8
CONSTRUCTION MORATORIUM (Trout):	G-8
CONSTRUCTION MORATORIUM (Tree Cutting):.....	G-8
MAJOR CONTRACT ITEMS:	G-9
SPECIALTY ITEMS:.....	G-9
SPECIAL REQUIREMENTS FOR WORK IN NATIONAL FOREST:	G-9
FUEL PRICE ADJUSTMENT:.....	G-12
STEEL PRICE ADJUSTMENT:.....	G-13
SCHEDULE OF ESTIMATED COMPLETION PROGRESS:.....	G-24
MINORITY BUSINESS ENTERPRISE AND WOMEN BUSINESS ENTERPRISE:.....	G-24
CONTRACTOR'S LICENSE REQUIREMENTS:.....	G-39
RESTRICTIONS ON ITS EQUIPMENT AND SERVICES:.....	G-39
USE OF UNMANNED AIRCRAFT SYSTEM (UAS):	G-39
EQUIPMENT IDLING GUIDELINES:.....	G-40
SUBSURFACE INFORMATION:.....	G-40
MAINTENANCE OF THE PROJECT:	G-41
ELECTRONIC BIDDING:.....	G-41
AWARD LIMITS:.....	G-42
TWELVE MONTH GUARANTEE:.....	G-42
OUTSOURCING OUTSIDE THE USA:.....	G-43
EROSION AND SEDIMENT CONTROL/STORMWATER CERTIFICATION:	G-43
NOTE TO CONTRACTOR (MATERIAL ACQUISITION):	G-48
PROCEDURE FOR MONITORING BORROW PIT DISCHARGE:.....	G-48
 ROADWAY.....	 R-1

STANDARD SPECIAL PROVISIONS

AVAILABILITY FUNDS – TERMINATION OF CONTRACTS	SSP-1
NCDOT GENERAL SEED SPECIFICATION FOR SEED QUALITY	SSP-2
ERRATA.....	SSP-5
PLANT AND PEST QUARANTINES	SSP-13
MINIMUM WAGES	SSP-14

TITLE VI AND NONDISCRIMINATION SSP-15
 ON-THE-JOB TRAINING SSP-23

UNIT PROJECT SPECIAL PROVISIONS

GEOTECHNICALGT-1.1
 TRAFFIC CONTROL TC-1
 UTILITY CONSTRUCTION UC-1
 UTILITY COORDINATION US-1
 UTILITY BY OTHERSUBO-1
 EROSION CONTROL EC-1
 LANDSCAPINGL-1
 TRAFFIC SIGNALS TS-1
 STRUCTURE / CULVERTS..... ST-1

PERMITSP-1

PROPOSAL ITEM SHEET

ITEM SHEET(S)

PROJECT SPECIAL PROVISIONS**GENERAL****CONTRACTOR PREQUALIFICATION:**

(10-18-22)(Rev. 7-18-23)

102

SP1 G01

Revise the *2018 Standard Specifications* as follows:

Page 1-9, Subarticle 102-2(A)(1) Bidder Prequalification, lines 34-36, delete and replace the first sentence with the following:

Applicant shall submit a completed Department Prequalification Application and *Bidder Experience Questionnaire*, along with any additional supporting information requested by the Department, as noted in the application and experience questionnaire package.

Page 1-10, Subarticle 102-2(A) Bidder Prequalification, lines 30-31, delete and replace the first sentence with the following:

Prospective bidders shall obtain prequalification approval at least two business days prior to any letting in which they intend to submit a bid. It is recommended that the prospective bidder file all required statements and documents with the State Prequalifications Engineer no less than 4 weeks before a given letting.

Page 1-10, Subarticle 102-2(B) Purchase Order Bidder Prequalification, lines 34-39, delete and replace the title and first paragraph with the following:

(B) Purchase Order (PO) Prime Contractor Prequalification

Contractors who have been approved to be placed on the Prequalified Bidders' List as noted above may perform work for the Department as a Purchase Order (PO) Prime Contractor and need not apply further. However, Purchase Order (PO) Prime Contractors will not be placed on the Prequalified Bidders' List unless they submit through the prequalification process described above.

Page 1-9, Subarticle 102-2(B)(1) Purchase Order Bidder Prequalification, lines 40-42, delete and replace the first sentence with the following:

Applicant shall submit a completed Department Prequalification Application along with any additional supporting information requested by the Department, as noted in the application.

Page 1-11, Subarticle 102-2(B) Purchase Order Bidder Prequalification, lines 16-18, delete and replace the first sentence with the following:

Prospective bidders shall obtain prequalification approval at least two business days prior to any letting in which they intend to submit a bid. It is recommended that the applicant file all required statements and documents with the State Prequalifications Engineer no less than 4 weeks before a given bid opening for their bid to be considered.

Page 1-11, Subarticle 102-2(C) Subcontractor Prequalification, lines 22-26, delete and replace the first paragraph with the following:

Contractors who have been approved to be placed on the Prequalified Bidders' List or the Purchase Order (PO) Prime Contractor's List as noted above may perform work for the Department as a subcontractor and need not apply further. However, subcontractors will not be placed on the Prequalified List or the Purchase Order (PO) Prime Contractor's List unless they submit through the prequalification process described above.

Page 1-11, Subarticle 102-2(C)(1) Subcontractor Prequalification, lines 27-28, delete and replace the first sentence with the following:

Applicant shall submit a completed Department Prequalification Application along with any additional supporting information requested by the Department, as noted in the application.

Page 1-11, Subarticle 102-2(C) Subcontractor Prequalification, lines 44-45, delete and replace the first sentence with the following:

The subcontractor shall file all required statements and documents with the State Prequalifications Engineer no less than 4 weeks before beginning work.

Page 1-12, Subarticle 102-2(E) Renewal and Requalification, lines 38-40, delete and replace the first sentence with the following:

It is recommended that the renewing or requalifying firm file all required statements and documents with the State Prequalifications Engineer no less than 4 weeks before a given letting for their bid to be considered.

INTERESTED PARTIES LIST:

(6-21-22)(Rev. 7-19-22)

102

SP1 G02

Revise the *2018 Standard Specifications* as follows:

Page 1-12, Article 102-3 PROPOSALS AND PLAN HOLDER LISTS, lines 45-49, delete and replace with the following:

102-3 PROPOSALS AND INTERESTED PARTIES LIST

On Department projects advertised, the prospective bidder shall sign up on the *Interested Parties List* no later than one business day prior to the Letting day of that project, for which he intends to submit a bid. There is no cost for signing up on the *Interested Parties List* that can be found on the Department's website at connect.ncdot.gov/letting.

Page 1-12, Article 102-3 PROPOSALS AND PLAN HOLDER LISTS, lines 1-3, delete and replace the first sentence of the second paragraph with the following:

The proposal will state the location of the contemplated construction and show a schedule of

contract items with the approximate quantity of each of these items for which bid prices are invited.

Page 1-14, Article 102-8 PREPARATION AND SUBMISSION OF BIDS, lines 30-31, delete and replace the first paragraph with the following:

Prior to submitting a bid on a project, the bidder shall sign up on the *Interested Parties List* in conformance with Article 102-3. The bidder shall submit a unit or lump sum price for every item in the proposal other than items that are authorized alternates to those items for which a bid price has been submitted.

LIABILITY INSURANCE:

(5-16-23)

107

SP1 G05

Revise the *2018 Standard Specifications* as follows:

Page 1-64, Article 107-15 LIABILITY INSURANCE, replace the first sentence with the following:

The Contractor shall at its sole cost and expense obtain and furnish to the Department an original standard Association for Cooperative Operations Research and Development (ACORD) certificate of liability insurance evidencing commercial general liability with a limit for bodily injury and property damage in the amount of \$5,000,000 per occurrence and \$5,000,000 general aggregate, covering the Contractor from claims or damages for bodily injury, personal injury, or for property damages that may arise from operating under the contract by the employees and agents of the Contractor.

CONTRACT TIME AND LIQUIDATED DAMAGES:

(8-15-00) (Rev. 5-16-23)

108

SP1 G08 A

The date of availability for this contract is **January 2, 2024 (for Tree Clearing Operations only), except April 15, 2024 (for -Y2- from Sta. 15+00 ± to Sta. 27+30.38), except July 1, 2024 (for the remainder of the project)**, except that work in jurisdictional waters and wetlands shall not begin until a meeting between the DOT, Regulatory Agencies, and the Contractor is held as stipulated in the permits contained elsewhere in this proposal. This delay in availability has been considered in determining the contract time for this project.

The completion date for this contract is **May 14, 2027**.

Except where otherwise provided by the contract, observation periods required by the contract will not be a part of the work to be completed by the completion date and/or intermediate contract times stated in the contract. The acceptable completion of the observation periods that extend beyond the final completion date shall be a part of the work covered by the performance and payment bonds.

The liquidated damages for this contract are **Two Hundred Dollars (\$200.00)** per calendar day. These liquidated damages will not be cumulative with any liquidated damages which may become chargeable under Intermediate Contract Time Number 1.

INTERMEDIATE CONTRACT TIME NUMBER 1 AND LIQUIDATED DAMAGES:

(7-1-95) (Rev. 2-21-12)

108

SP1 G13 A

Except for that work required under the Project Special Provisions entitled *Planting, Reforestation* and/or *Permanent Vegetation Establishment*, included elsewhere in this proposal, the Contractor will be required to complete all work included in this contract and shall place and maintain traffic on same.

The date of availability for this intermediate contract time is **January 2, 2024 (for Tree Clearing Operations only), except April 15, 2024 (for -Y2- from Sta. 15+00 ± to Sta. 27+30.38), except July 1, 2024 (for the remainder of the project).**

The completion date for this intermediate contract time is **October 1, 2026.**

The liquidated damages for this intermediate contract time are **Two Thousand Dollars (\$ 2,000.00)** per calendar day.

Upon apparent completion of all the work required to be completed by this intermediate date, a final inspection will be held in accordance with Article 105-17 and upon acceptance, the Department will assume responsibility for the maintenance of all work except *Planting, Reforestation* and/or *Permanent Vegetation Establishment*. The Contractor will be responsible for and shall make corrections of all damages to the completed roadway caused by his planting operations, whether occurring prior to or after placing traffic through the project.

INTERMEDIATE CONTRACT TIME NUMBER 2 AND LIQUIDATED DAMAGES:

(2-20-07)

108

SP1 G14 A

The Contractor shall complete the required work of installing, maintaining, and removing the traffic control devices for lane closures and restoring traffic to the existing traffic pattern. The Contractor shall not close or narrow a lane of traffic on **US 64 / US 276 (-L-)** during the following time restrictions:

DAY AND TIME RESTRICTIONS

June 1 thru October 31 (of Any Year)
Monday thru Sunday, 7:00 AM to 9:00 PM

November 1 (of Any Year) thru May 31 (of the Following Year)
Monday thru Friday, 7:00 AM to 8:30 AM and 4:00 PM to 6:00 PM

In addition, the Contractor shall not close or narrow a lane of traffic on **US 64 / US 276 (-L-)**, detain and/or alter the traffic flow on or during holidays, holiday weekends, special events, or any other time when traffic is unusually heavy, including the following schedules:

HOLIDAY AND HOLIDAY WEEKEND LANE CLOSURE RESTRICTIONS

1. For **unexpected occurrence** that creates unusually high traffic volumes, as directed by the Engineer.

2. For **New Year's Day**, between the hours of **9:00 PM** December 31st and **7:00 AM** January 2nd. If New Year's Day is on a Friday, Saturday, Sunday or Monday, then until **7:00 AM** the following Tuesday.
3. For **Easter**, between the hours of **9:00 PM** Thursday and **7:00 AM** Monday.
4. For **Memorial Day**, between the hours of **9:00 PM** Friday and **7:00 AM** Tuesday.
5. For **Independence Day**, between the hours of **9:00 PM** the day before Independence Day and **7:00 AM** the day after Independence Day.

If **Independence Day** is on a Friday, Saturday, Sunday or Monday, then between the hours of **9:00 PM** the Thursday before Independence Day and **7:00 AM** the Tuesday after Independence Day.
6. For **Labor Day**, between the hours of **9:00 PM** Friday and **7:00 AM** Tuesday.
7. For **Thanksgiving**, between the hours of **9:00 PM** Tuesday and **7:00 AM** Monday.
8. For **Christmas**, between the hours of **9:00 PM** the Friday before the week of Christmas Day and **7:00 AM** the following Tuesday after the week of Christmas Day.
9. For **Autumn Leaf Season, from October 1st thru November 30th, Monday thru Sunday**, between the hours of **6:00 AM** and **9:00 PM**.

Holidays and holiday weekends shall include New Year's, Easter, Memorial Day, Independence Day, Labor Day, Thanksgiving, and Christmas. The Contractor shall schedule his work so that lane closures will not be required during these periods, unless otherwise directed by the Engineer.

The time of availability for this intermediate contract work shall be the time the Contractor begins to install all traffic control devices for lane closures according to the time restrictions listed herein.

The completion time for this intermediate contract work shall be the time the Contractor is required to complete the removal of all traffic control devices for lane closures according to the time restrictions stated above and place traffic in the existing traffic pattern.

The liquidated damages are **One Thousand Two Hundred Fifty Dollars (\$ 1,250.00)** per fifteen **(15)** minute time period.

INTERMEDIATE CONTRACT TIME NUMBER 3 AND LIQUIDATED DAMAGES:

(2-20-07)

108

SP1 G14 A

The Contractor shall complete the required work of installing, maintaining and removing the traffic control devices for lane closures and restoring traffic to the existing traffic pattern. The Contractor shall not close or narrow a lane of traffic on **the following roads** during the following time restrictions:

DAY AND TIME RESTRICTIONS**NC 280 (-L-) and/or US 276 (-Y3-), from June 1 thru October 31 (of Any Year)****Monday thru Sunday, 7:00 AM to 9:00 PM****NC 280 (-L-) and/or US 276 (-Y3-), November 1 (of Any Year)
thru May31 (of the Following Year)****Monday thru Friday, 7:00 AM to 8:30 AM and 4:00 PM to 6:00 PM****US 64 (-Y2-, from Sta. 10+85 ± to end of project)****Monday thru Friday, 7:00 AM to 8:30 AM and 4:00 PM to 6:00 PM****Ecusta Road (-Y1-) (When School is in Session)****Monday thru Friday, 7:00 AM to 8:30 AM and 2:30 PM to 4:30 PM**

In addition, the Contractor shall not close or narrow a lane of traffic on **US 64 (-Y2-), US 276 (-Y3-), NC 280 (-L-) and/or Ecusta Road (-Y1-)**, detain and/or alter the traffic flow on or during holidays, holiday weekends, special events, or any other time when traffic is unusually heavy, including the following schedules:

HOLIDAY AND HOLIDAY WEEKEND LANE CLOSURE RESTRICTIONS

1. For **unexpected occurrence** that creates unusually high traffic volumes, as directed by the Engineer.
2. For **New Year's Day**, between the hours of **9:00 PM** December 31st and **7:00 AM** January 2nd. If New Year's Day is on a Friday, Saturday, Sunday or Monday, then until **7:00 AM** the following Tuesday.
3. For **Easter**, between the hours of **9:00 PM** Thursday and **7:00 AM** Monday.
4. For **Memorial Day**, between the hours of **9:00 PM** Friday and **7:00 AM** Tuesday.
5. For **Independence Day**, between the hours of **9:00 PM** the day before Independence Day and **7:00 AM** the day after Independence Day.

If **Independence Day** is on a Friday, Saturday, Sunday or Monday, then between the hours of **9:00 PM** the Thursday before Independence Day and **7:00 AM** the Tuesday after Independence Day.

6. For **Labor Day**, between the hours of **9:00 PM** Friday and **7:00 AM** Tuesday.

7. For **Thanksgiving**, between the hours of **9:00 PM** Tuesday and **7:00 AM** Monday.
8. For **Christmas**, between the hours of **9:00 PM** the Friday before the week of Christmas Day and **7:00 AM** the following Tuesday after the week of Christmas Day.
9. For **Autumn Leaf Season**, from **October 1st thru November 30th**, **Monday thru Sunday**, between the hours of **6:00 AM** and **9:00 PM**.

Holidays and holiday weekends shall include New Year's, Easter, Memorial Day, Independence Day, Labor Day, Thanksgiving, and Christmas. The Contractor shall schedule his work so that lane closures will not be required during these periods, unless otherwise directed by the Engineer.

The time of availability for this intermediate contract work shall be the time the Contractor begins to install all traffic control devices for lane closures according to the time restrictions listed herein.

The completion time for this intermediate contract work shall be the time the Contractor is required to complete the removal of all traffic control devices for lane closures according to the time restrictions stated above and place traffic in the existing traffic pattern.

The liquidated damages are **Two Hundred Fifty Dollars (\$ 250.00)** per hour.

INTERMEDIATE CONTRACT TIME NUMBER 4 AND LIQUIDATED DAMAGES:

(2-20-07) (Rev. 6-18-13)

108

SP1 G14 H

The Contractor shall complete the work required of **Phase V, Step #1** as shown on Sheet **TMP-3A** and shall place and maintain traffic on same. **No work required of this Intermediate Contract Time may occur during the Autumn Leaf Season, as described in Intermediate Contract Time Number 2.**

The date of availability for this intermediate contract time is the date the Contractor elects to begin the work.

The completion date for this intermediate contract time is the date which is **fourteen (14)** consecutive calendar days after and including the date the Contractor begins this work.

The liquidated damages are **Five Thousand Dollars (\$ 5,000.00)** per calendar day. **The liquidated damages associated with Intermediate Contract Time Number 2 will not apply to this work.**

INTERMEDIATE CONTRACT TIME NUMBER 5 AND LIQUIDATED DAMAGES:

(2-20-07) (Rev. 6-18-13)

108

SP1 G14 H

The Contractor shall complete the work required of **Phase VI, Step #1C** as shown on Sheet **TMP-3A** and shall place and maintain traffic on same. **No work required of this Intermediate Contract Time may occur during the Autumn Leaf Season, as described in Intermediate Contract Time Number 2 & Intermediate Contract Time Number 3.**

The date of availability for this intermediate contract time is the date the Contractor elects to begin the work.

The completion date for this intermediate contract time is the date which is **five (5)** consecutive calendar days after and including the date the Contractor begins this work.

The liquidated damages are **Five Thousand Dollars (\$ 5,000.00)** per calendar day. **The liquidated damages associated with Intermediate Contract Time Number 2 & Intermediate Contract Time Number 3 will not apply to this work.**

PERMANENT VEGETATION ESTABLISHMENT:

(2-16-12) (Rev. 10-15-13)

104

SP1 G16

Establish a permanent stand of the vegetation mixture shown in the contract. During the period between initial vegetation planting and final project acceptance, perform all work necessary to establish permanent vegetation on all erodible areas within the project limits, as well as, in borrow and waste pits. This work shall include erosion control device maintenance and installation, repair seeding and mulching, supplemental seeding and mulching, mowing, and fertilizer topdressing, as directed. All work shall be performed in accordance with the applicable section of the *2018 Standard Specifications*. All work required for initial vegetation planting shall be performed as a part of the work necessary for the completion and acceptance of the Intermediate Contract Time (ICT). Between the time of ICT and Final Project acceptance, or otherwise referred to as the vegetation establishment period, the Department will be responsible for preparing the required National Pollutant Discharge Elimination System (NPDES) inspection records.

Once the Engineer has determined that the permanent vegetation establishment requirement has been achieved at an 80% vegetation density (the amount of established vegetation per given area to stabilize the soil) and no erodible areas exist within the project limits, the Contractor will be notified to remove the remaining erosion control devices that are no longer needed. The Contractor will be responsible for, and shall correct any areas disturbed by operations performed in permanent vegetation establishment and the removal of temporary erosion control measures, whether occurring prior to or after placing traffic on the project.

Payment for *Response for Erosion Control, Seeding and Mulching, Repair Seeding, Supplemental Seeding, Mowing, Fertilizer Topdressing, Silt Excavation, and Stone for Erosion Control* will be made at contract unit prices for the affected items. Work required that is not represented by contract line items will be paid in accordance with Articles 104-7 or 104-3 of the *2018 Standard Specifications*. No additional compensation will be made for maintenance and removal of temporary erosion control items.

CONSTRUCTION MORATORIUM (Trout):

(7-15-14)

SP1 G18A

No in-water work or land disturbance within the 25 feet wide buffer zone will be allowed from **October 15th** of any year through **April 15th** of the following year.

CONSTRUCTION MORATORIUM (Tree Cutting):

(1-19-16)

SP1 G18C

No tree cutting will be allowed from **April 1st** through **October 15th** of any year.

MAJOR CONTRACT ITEMS:

(2-19-02)

104

SP1 G28

The following listed items are the major contract items for this contract (see Article 104-5 of the 2018 Standard Specifications):

Line #	Description
6	— Borrow Excavation
40	— Asphalt Concrete Intermediate Course, Type I19.0 C
41	— Asphalt Concrete Surface Course, Type S9.5 B
136	— 10" Water Line

SPECIALTY ITEMS:

(7-1-95)(Rev. 7-20-21)

108-6

SP1 G37

Items listed below will be the specialty items for this contract (see Article 108-6 of the 2018 Standard Specifications).

Line #	Description
74-81	Guardrail
82	Fencing
86-99	Signing
115-120	Long-Life Pavement Markings
131	Permanent Pavement Markers
133-172	Utility Construction
173-201, 203-204	Erosion Control
202	Reforestation
205-266	Planting
267-308	Signals/ITS System

SPECIAL REQUIREMENTS FOR WORK IN NATIONAL FOREST:

(7-1-95)

107-13

SP1 G40

In addition to other requirements in this proposal with respect to clearing, erosion control, protection of environment, etc., comply with the following requirements:

- (A) Comply with the portions of these Special Requirements, entitled "Fire Plan," "Clearing Plan," and "Landscape and Erosion Control Plan." Note the fact that merchantable timber within Forest Service Property will become the property of the Contractor.
- (B) Comply with the following recommendations of the State Fish and Game Department and Forest Service for wildlife and fish management:
 - (1) Take all necessary precautions to avoid damage to fish habitat and exercise every reasonable precaution to prevent muddying or silting live streams.
 - (2) Do not deposit material removed from the roadway or channel changes in live streams or into the streams or stream channel where it would be washed away by high stream flows.

- (3) Do not haul materials, including logs, brush, and debris, by fording live streams. Instead, provide temporary bridges or other structures for this purpose.
- (C) Dispose of waste material resulting from slides during construction and surplus material at locations approved by the Forest Supervisor. Submit a plan showing the proposed method of disposal at the time approval is requested.
- (D) Treat sections of existing road to be abandoned as a result of the proposed new construction, as designated by the Forest Supervisor, to restore them to their natural state. The necessary treatment will be determined during a joint review between the Forest Service and the State and may include ripping of roadbed, removal of drainage structure, and opening drainage channels. Plans and specifications as mutually deemed appropriate to accomplish the objective will become a part of this stipulation.
- (E) Permanently monument the right of way prior to completion of construction in accordance with State requirements for such right of way, but in any event the minimum requirements will be to place permanent monuments at the intersection of right of way with all property lines, section lines, and at intervals of not more than 1,000 feet along the right-of-way limits.
- (F) Re-establish or restore public land monuments disturbed or destroyed by construction, reconstruction, or maintenance according to instructions of the Bureau of Land Management, Department of the Interior. Do not damage, destroy, or obliterate other land monuments and property corners or witness markers without the prior permission of the Regional Forester. Relocate or re-establish these land monuments, property corners, and witness markers in accordance with standards satisfactory to the Regional Forester.

Fire Protection Plan

During the period of construction, perform both independently and in cooperation with the Forest Service everything that is reasonable and practical to prevent and suppress forest fires on the easement area and in its immediate vicinity. Include provisions in all subcontracts for the construction of the road requiring subcontractors and their respective employees to do likewise. The contractors and subcontractors, shall conform to, but not be limited to, the following Fire Plan:

- (A) Take immediate independent or cooperative action to control and extinguish any fire, regardless of cause, within the easement area and its vicinity.
- (B) Maintain at readily available sites one or more boxes of firefighting tools to be furnished by the Forest Service for forest fire fighting purposes only.
- (C) Perform debris burning only in the center of the right of way, and only after a strip 20 feet wide around each pile is cleared to mineral soil.
- (D) Keep fires compact by throwing in the larger material as it burns. If piles are too close together or burn hot, light every second or third pile; allow these to cool down before firing

- the others. On slopes start burning at the top and work down. Confine fires to piles at all times.
- (E) Do not leave fires unattended.
 - (F) Discontinue burning upon notification by the District Forest Ranger or his representative that fire danger is such that there is abnormal risk.
 - (G) Whenever a fire escapes, notify the District Ranger immediately even if the fire is suppressed without Forest Service assistance.
 - (H) The contractor or subcontractor responsible will bear the costs, including Forest Service direct costs and value of resources damages, incurred by the Forest Service in controlling and extinguishing any fire on or threatening National Forest lands which they or their employees caused with or without negligence in connection with construction operations.
 - (I) Contact the District Ranger 24 hours in advance of burning.

Clearing Plan

Conform to the following clearing plan:

- (A) Dispose of unmerchantable materials including tops, branches, etc., by piling and burning as directed by the Forest Service or used in brush barriers. Alternate methods of disposal, including any of the following methods or combinations of methods (lop and scatter, chip, remove, pile only), shall be approved in advance by the Forest Service.
- (B) The maximum clearing and grubbing limits are to be as shown on the plans except that cutting of hazard trees outside these limits may be done with approval. Confine construction machinery within the clearing limits.

Landscape and Erosion Control Plan

The erosion control plan will be designed and implemented to prevent visible sediment, as defined by NC DEQ regulations, from reaching any defined stream channel.

Conform to, but not be limited to, the following Landscape and Erosion Control Plan.

- (A) Prevent visible sediment from entering any stream channel. If an erosion control practice must be sited in a channel, it shall stop further down-channel transport of visible sediment.
- (B) Bear responsibility for the prevention and control of soil erosion and gully on the right of way and lands adjacent thereto resulting from the construction or maintenance of the road. Revegetate with grass (not Love Grass) or herbaceous plants all ground where the soil has been exposed. Accomplish revegetation within 20 working days following final grading.
- (C) Round the ends of cut sections and the tops of back slopes.

- (D) Vegetate all front and back slopes by liming, fertilizing, mulching and seeding; including any waste area. Mulch critical areas if they are to be exposed greater than 5 working days of probable inclement weather during seasons when seeding is impracticable. Critical areas include all bare soils within 100 feet (slope distance) of perennial and intermittent streams. Mulch these as soon as practical and after final seeding.
- (E) Maintain all erosion control practices in a timely manner to prevent visible sediment from entering any stream channel, until such time that the final revegetation stabilizes the site and prevents erosion and off-site movement of sediment.

FUEL PRICE ADJUSTMENT:

(11-15-05) (Rev. 11-15-22)

109-8

SP1 G43

Revise the *2018 Standard Specifications* as follows:

Page 1-87, Article 109-8, Fuel Price Adjustments, add the following:

The base index price for DIESEL #2 FUEL is \$ **3.4209** per gallon. Where any of the following are included as pay items in the contract, they will be eligible for fuel price adjustment.

The pay items and the fuel factor used in calculating adjustments to be made will be as follows:

Description	Units	Fuel Usage Factor Diesel
Unclassified Excavation	Gal/CY	0.29
Borrow Excavation	Gal/CY	0.29
Class IV Subgrade Stabilization	Gal/Ton	0.55
Aggregate Base Course	Gal/Ton	0.55
Sub-Ballast	Gal/Ton	0.55
Erosion Control Stone	Gal/Ton	0.55
Rip Rap, Class _____	Gal/Ton	0.55
Asphalt Concrete Base Course, Type _____	Gal/Ton	0.90 or 2.90
Asphalt Concrete Intermediate Course, Type _____	Gal/Ton	0.90 or 2.90
Asphalt Concrete Surface Course, Type _____	Gal/Ton	0.90 or 2.90
Open-Graded Asphalt Friction Course	Gal/Ton	0.90 or 2.90
Permeable Asphalt Drainage Course, Type _____	Gal/Ton	0.90 or 2.90
Sand Asphalt Surface Course, Type _____	Gal/Ton	0.90 or 2.90
Ultra-thin Bonded Wearing Course	Gal/Ton	0.90 or 2.90
Aggregate for Cement Treated Base Course	Gal/Ton	0.55
Portland Cement for Cement Treated Base Course	Gal/Ton	0.55
> 11" Portland Cement Concrete Pavement	Gal/SY	0.327
Concrete Shoulders Adjacent to > 11" Pavement	Gal/SY	0.327
9" to 11" Portland Cement Concrete Pavement	Gal/SY	0.272
Concrete Shoulders Adjacent to 9" to 11" Pavement	Gal/SY	0.272
< 9" Portland Cement Concrete Pavement	Gal/SY	0.245
Concrete Shoulders Adjacent to < 9" Pavement	Gal/SY	0.245

For the asphalt items noted in the chart as eligible for fuel adjustments, the bidder may include the *Fuel Usage Factor Adjustment Form* with their bid submission if they elect to use the fuel usage factor. The *Fuel Usage Factor Adjustment Form* is found at the following link:

<https://connect.ncdot.gov/letting/LetCentral/Fuel%20Usage%20Factor%20Adjustment%20Form%20-%20Starting%20Nov%202022%20Lettings.pdf>

Select either 2.90 Gal/Ton fuel factor or 0.90 Gal/Ton fuel factor for each asphalt line item on the *Fuel Usage Factor Adjustment Form*. The selected fuel factor for each asphalt item will remain in effect for the duration of the contract.

Failure to complete the *Fuel Usage Factor Adjustment Form* will result in using 2.90 gallons per ton as the Fuel Usage Factor for Diesel for the asphalt items noted above. The contractor will not be permitted to change the Fuel Usage Factor after the bids are submitted.

STEEL PRICE ADJUSTMENT:

(4-19-22)(Rev. 11-21-23)

SP1 G47

Description and Purpose

Steel price adjustments will be made to the payments due the Contractor for items as defined herein that are permanently incorporated into the work, when the price of raw steel mill products utilized on the contract have fluctuated. The Department will adjust monthly progress payments up or down as appropriate for cost changes in steel according to this provision.

Eligible Items

The list of eligible bid items for steel price adjustment can be found on the Departments website at the following address:

<https://connect.ncdot.gov/letting/LetCentral/Eligible%20Bid%20Items%20for%20Steel%20Price%20Adjustment.xlsx>

Nuts, bolts, anchor bolts, rebar chairs, connecting bands and other miscellaneous hardware associated with these items shall not be included in the price adjustment.

Adjustments will only be made for fluctuations in the material cost of the steel used in the above products as specified in the Product Relationship Table below. The producing mill is defined as the source of steel product before any fabrication has occurred (e.g., coil, plate, rebar, hot rolled shapes, etc.). No adjustment will be made for changes in the cost of fabrication, coating, shipping, storage, etc.

No steel price adjustments will be made for any products manufactured from steel having an adjustment date, as defined by the Product Relationship Table below, prior to the letting date.

Bid Submittal Requirements

The successful bidder, within 14 calendar days after the notice of award is received by him, shall provide the completed Form SPA-1 to the Department (State Contract Officer or Division Contract Engineer) along with the payment bonds, performance bonds and contract execution signature sheets in a single submittal. If Form SPA-1 is not included in the same submittal as the payment bonds, performance bonds and contract execution signature sheets, the Contractor will not be eligible for any steel price adjustment for any item in the contract for the life of the contract. Form SPA-1 can be found on the Department's website at the following address:

<https://connect.ncdot.gov/letting/LetCentral/Form%20SPA-1.xlsm>

The Contractor shall provide Form SPA-1 listing the Contract Line Number, (with corresponding Item Number, Item Description, and Category) for the steel products they wish to have an adjustment calculated. Only the contract items corresponding to the list of eligible item numbers for steel price adjustment may be entered on Form SPA-1. The Contractor may choose to have steel price adjustment applied to any, all, or none of the eligible items. However, the Contractor's selection of items for steel price adjustment or non-selection (non-participation) may not be changed once Form SPA-1 has been received by the Department. Items the Bidder chooses for steel price adjustment must be designated by writing the word "Yes" in the column titled "Option" by each Pay Item chosen for adjustment. Should the bidder elect an eligible steel price item, the entire quantity of the line item will be subject to the price adjustment for the duration of the Contract. The Bidder's designations on Form SPA-1 must be written in ink or typed and signed by the Bidder (Prime Contractor) to be considered complete. Items not properly designated, designated with "No", or left blank on the Bidder's Form SPA-1 will automatically be removed from consideration for adjustment. No steel items will be eligible for steel price adjustment on this Project if the Bidder fails to return Form SPA-1 in accordance with this provision.

Establishing the Base Price

The Department will use a blend of monthly average prices as reported from the Fastmarkets platform to calculate the monthly adjustment indices (BI and MI). This data is typically available on the first day of the month for the preceding month. The indices will be calculated by the Department for the different categories found on the Product Relationship Table below. For item numbers that include multiple types of steel products, the category listed for that item number will be used for adjusting each steel component.

The bidding index for Category 1 Steel items is **\$ 42.25** per hundredweight.

The bidding index for Category 2 Steel items is **\$ 71.45** per hundredweight.

The bidding index for Category 3 Steel items is **\$ 62.50** per hundredweight.

The bidding index for Category 4 Steel items is **\$ 37.30** per hundredweight.

The bidding index for Category 5 Steel items is **\$ 53.94** per hundredweight.

The bidding index for Category 6 Steel items is **\$ 65.26** per hundredweight.

The bidding index for Category 7 Steel items is **\$ 43.68** per hundredweight.

The bidding index represents a selling price of steel based on Fastmarkets data for the month of **September 2023**.

MI = Monthly Index. – in Dollars (\$) per hundredweight (CWT). Use the adjustment indices from the month the steel was shipped from the

producing mill, received on the project, or member cast as defined in the Product Relationship Table.

BI = Bidding Index. - in Dollars (\$) per hundredweight (CWT). Use the adjustment indices as listed in the proposal.

<i>Steel Product (Title)</i>	BI, MI*	Adjustment Date for MI	Category
Reinforcing Steel, Bridge Deck, and SIP Forms	Based on one or more Fastmarkets indices	Delivery Date from Producing Mill	1
Structural Steel and Encasement Pipe	Based on one or more Fastmarkets indices	Delivery Date from Producing Mill	2
Steel H-Piles, Soldier Pile Walls	Based on one or more Fastmarkets indices	Delivery Date from Producing Mill	3
Guardrail Items and Pipe Piles	Based on one or more Fastmarkets indices	Material Received Date**	4
Fence Items	Based on one or more Fastmarkets indices	Material Received Date**	5
Overhead Sign Assembly, Signal Poles, High Mount Standards	Based on one or more Fastmarkets indices	Material Received Date**	6
Prestressed Concrete Members	Based on one or more Fastmarkets indices	Cast Date of Member	7

Submit documentation to the Engineer for all items listed in the Contract for which the Contractor is requesting a steel price adjustment.

Submittal Requirements

The items in categories 1,2, and 3, shall be specifically stored, labeled, or tagged, recognizable by color marking, and identifiable by Project for inspection and audit verification immediately upon arrival at the fabricator.

Furnish the following documentation for all steel products to be incorporated into the work and documented on Form SPA-2, found on the Departments website at the following address:

<https://connect.ncdot.gov/projects/construction/Construction%20Forms/Form%20SPA-2.xlsx>

Submit all documentation to the Engineer prior to incorporation of the steel into the completed work. The Department will withhold progress payments for the affected contract line item if the documentation is not provided and at the discretion of the Engineer the work is allowed to proceed. Progress payments will be made upon receipt of the delinquent documentation.

Step 1 (Form SPA -2)

Utilizing Form SPA-2, submit separate documentation packages for each line item from Form SPA-1 for which the Contractor opted for a steel price adjustment. For line items with multiple components of steel, each component should be listed separately. Label each SPA-2 documentation package with a unique number as described below.

- a. Documentation package number: (Insert the contract line-item) - (Insert sequential package number beginning with "1").
Example: 412 - 1,
 412 - 2,
 424 - 1,
 424 - 2,
 424 - 3, etc.
- b. The steel product quantity in pounds
 - i. The following sources should be used, in declining order of precedence, to determine the weight of steel/iron, based on the Engineers decision:
 1. Department established weights of steel/iron by contract pay item per pay unit;
 2. Approved Shop Drawings;
 3. Verified Shipping Documents;
 4. Contract Plans;
 5. Standard Drawing Sheets;
 6. Industry Standards (i.e., AISC Manual of Steel Construction, AWWA Standards, etc.); and
 7. Manufacture's data.
 - ii. Any item requiring approved shop drawings shall have the weights of steel calculated and shown on the shop drawings or submitted and certified separately by the fabricator.
- c. The date the steel product, subject to adjustment, was shipped from the producing mill (Categories 1-3), received on the project (Categories 4-6), or casting date (Category 7).

Step 2 (Monthly Calculator Spreadsheet)

For each month, upon the incorporation of the steel product into the work, provide the Engineer the following:

- 1) Completed NCDOT Steel Price Adjustment Calculator Spreadsheet, summarizing all the steel submittal packages (Form SPA-2) actually incorporated into the completed work in the given month.
 - a. Contract Number
 - b. Bidding Index Reference Month
 - c. Contract Completion Date or Revised Completion Date
 - d. County, Route, and Project TIP information
 - e. Item Number
 - f. Line-Item Description
 - g. Submittal Number from Form SPA-2
 - h. Adjustment date
 - i. Pounds of Steel
- 2) An affidavit signed by the Contractor stating the documentation provided in the NCDOT Steel Price Adjustment Calculator Spreadsheet is true and accurate.

Price Adjustment Conditions

Download the Monthly Steel Adjustment Spreadsheet with the most current reference data from the Department's website each month at the following address:

<https://connect.ncdot.gov/projects/construction/Construction%20Forms/Form%20SPA-3%20NCDOT%20Steel%20Price%20Adjustment%20Calculator.xlsx>

If the monthly Fastmarkets data is not available, the data for the most recent immediately preceding month will be used as the basis for adjustment.

Price Adjustment Calculations

The price adjustment will be determined by comparing the percentage of change in index value listed in the proposal (BI) to the monthly index value (MI). (See included sample examples). Weights and date of shipment must be documented as required herein. The final price adjustment dollar value will be determined by multiplying this percentage increase or decrease in the index by the represented quantity of steel incorporated into the work, and the established bidding index (BI) subject to the limitations herein.

Price increase/decrease will be computed as follows:

$$\text{SPA} = ((\text{MI} / \text{BI}) - 1) * \text{BI} * (\text{Q} / 100)$$

Where;

SPA = Steel price adjustment in dollars

MI = Monthly Shipping Index. – in Dollars (\$) per hundredweight (CWT). Use the adjustment indices from the month the steel was shipped from the producing mill, received on the project, or member cast as defined in the Product Relationship Table.

BI = Bidding Index. - in Dollars (\$) per hundredweight (CWT). Use the adjustment indices as listed in the proposal.

Q = Quantity of steel, product, pounds actually incorporated into the work as documented by the Contractor, or Design Build Team and verified by the Engineer.

Calculations for price adjustment shall be shown separate from the monthly progress estimate and will not be included in the total cost of work for determination of progress or for extension of Contract time in accordance with Subarticle 108-10(B)(1).

Any apparent attempt to unbalance bids in favor of items subject to price adjustment may result in rejection of the bid proposal.

Adjustments will be paid or charged to the Contractor only. Any Contractor receiving an adjustment under this provision shall distribute the proper proportional part of such adjustments to the subcontractor who performed the applicable work.

Delays to the work caused by steel shortages may be justification for a Contract time extension but will not constitute grounds for claims for standby equipment, extended office overhead, or other costs associated with such delays.

If an increase in the steel material price is anticipated to exceed 50% of the original quoted price, the contractor must notify the Department within 7 days prior to purchasing the material. Upon receipt of such notification, the Department will direct the Contractor to either (1) proceed with the work or (2) suspend the work and explore the use of alternate options.

If the decrease in the steel material exceeds 50% of the original quoted price, the contractor may submit to the Department additional market index information specific to the item in question to dispute the decrease. The Department will review this information and determine if the decrease is warranted.

When the steel product adjustment date, as defined in the Product Relationship Table, is after the approved contract completion date, the steel price adjustments will be based on the lesser value of either the MI for the month of the approved contract completion date or the MI for the actual adjustment date.

If the price adjustment is based on estimated material quantities for that time, and a revision to the total material quantity is made in a subsequent or final estimate, an appropriate adjustment will be made to the price adjustment previously calculated. The adjustment will be based on the same indices used to calculate the price adjustment which is being revised. If the adjustment date of the revised material quantity cannot be determined, the adjustment for the quantity in question, will be based on the indices utilized to calculate the steel price adjustment for the last initial documentation package submission, for the steel product subject to adjustment, that was incorporated into the particular item of work, for which quantities are being finalized.

Example: Structural steel for a particular bridge was provided for in three different shipments with each having a different mill shipping date. The quantity of structural steel actually used for the bridge was calculated and a steel price adjustment was made in a progress payment. At the conclusion of the work an error was found in the plans of the final quantity of structural steel used for the bridge. The quantity to be adjusted cannot be directly related to any one of the three mill shipping dates. The steel price adjustment for the quantity in question would be calculated using the indices that were utilized to calculate the steel price adjustment for the quantity of structural steel represented by the last initial structural steel documentation package submission. The package used will be the one with the greatest sequential number.

Extra Work/Force Account:

When steel products, as specified herein, are added to the contract as extra work, in accordance with the provisions of Article 104-7 or 104-3, the Engineer will determine and specify in the supplemental agreement, the need for application of steel price adjustments on a case-by-case basis. No steel price adjustments will be made for any products manufactured from steel having an adjustment date prior to the supplemental agreement execution date. Price adjustments will be made as provided herein, except the Bidding Index will be based on the month in which the supplemental agreement pricing was executed.

For work performed on force account basis, reimbursement of actual material costs, along with the specified overhead and profit markup, will be considered to include full compensation for the current cost of steel and no steel price adjustments will be made.

**Examples Form SPA-2
Steel Price Adjustment Submission Form**

Contract Number C203394 Bid Reference Month January 2019
 Submittal Date 8/31/2019
 Contract Line Item 237
 Line Item Description APPROX....LBS Structural Steel
 Sequential Submittal Number 2

Supplier	Description of material	Location information	Quantity in lbs.	Adjustment Date
XYZ mill	Structural Steel	Structure 3, Spans A-C	1,200,000	May 4, 2020
ABC distributing	Various channel & angle shapes	Structure 3 Spans A-C	35,000	July 14, 2020
		Total Pounds of Steel	1,235,000	

Note: Attach the following supporting documentation to this form.

- Bill of Lading to support the shipping dates
- Supporting information for weight documentation (e.g., Pay item reference, Shop drawings, shipping documents, Standards Sheets, industry standards, or manufacturer's data)

By providing this data under my signature, I attest to the accuracy of and validity of the data on this form and certify that no deliberate misrepresentation in any manner has occurred.

Printed Name _____ Signature _____

**Examples Form SPA-2
Steel Price Adjustment Submission Form**

Contract Number C203394 Bid Reference Month January 2019

Submittal Date August 31, 2019Contract Line Item 237Line Item Description SUPPORT, OVRHD SIGN STR -DFEB – STA 36+00Sequential Submittal
Number 2

Supplier	Description of material	Location information	Quantity in lbs.	Adjustment Date
XYZ mill	Tubular Steel (Vertical legs)	<u>-DFEB – STA 36+00</u>	12000	December 11, 2021
PDQ Mill	4" Tubular steel (Horizontal legs)	<u>-DFEB – STA 36+00</u>	5900	December 11, 2021
ABC distributing	Various channel & angle shapes (see quote)	<u>-DFEB – STA 36+00</u>	1300	December 11, 2021
	Catwalk assembly	<u>-DFEB – STA 36+00</u>	2000	December 11, 2021
Nucor	Flat plate	<u>-DFEB – STA 36+00</u>	650	December 11, 2021
		Total Pounds of Steel	21,850	

Note: Attach the following supporting documentation to this form.

- Bill of Lading to support the shipping dates
- Supporting information for weight documentation (e.g., Pay item reference, Shop drawings, shipping documents, Standards Sheets, industry standards, or manufacturer's data)

By providing this data under my signature, I attest to the accuracy of and validity of the data on this form and certify that no deliberate misrepresentation in any manner has occurred.

Printed Name

Signature

Price Adjustment Sample Calculation (increase)

Project bid on September 17, 2019

Line Item 635 "Structural Steel" has a plan quantity of 2,717,000 lbs.

Bidding Index for Structural Steel (Category 2) in the proposal was \$36.12/CWT = BI

450,000 lbs. of Structural Steel for Structure 2 at Station 44+08.60 were shipped to fabricator from the producing mill in same month, May 2021.

Monthly Index for Structural Steel (Category 2) for May 2021 was \$64.89/CWT = MI

The Steel Price Adjustment formula is as follows:

$$\text{SPA} = ((\text{MI} / \text{BI}) - 1) * \text{BI} * (\text{Q} / 100)$$

Where; SPA = Steel price adjustment in dollars

BI = Bidding Index – in dollars (\$) per hundredweight (CWT). Use the adjustment indices as listed in the proposal.

MI = Mill Shipping Index – in dollars (\$) per hundredweight (CWT). Use the adjustment indices from the month the steel was shipped from the producing mill, received on the project, or member cast as defined in the Product Relationship Table.

Q = Quantity of steel product, in pounds (lbs.) actually incorporated into the work as documented by the Contractor, or Design Build Team and verified by the Engineer.

$$\text{BI} = \$36.12 / \text{CWT}$$

$$\text{MI} = \$64.89 / \text{CWT}$$

$$\% \text{ change} = ((\text{MI} / \text{BI}) - 1) = (\$64.89 / \$36.12 - 1) = (1.79651 - 1) = 0.79651162791$$

$$\text{Q} = 450,000 \text{ lbs.}$$

$$\text{SPA} = 0.79651162791 \times \$36.12 \times (450,000 / 100)$$

$$\text{SPA} = 0.79651162791 * \$36.12 * 4,500$$

$$\text{SPA} = \$129,465 \text{ pay adjustment to Contractor for Structural Steel (Structure 2 at Station 44+08.60)}$$

Price Adjustment Sample Calculation (decrease)

Project bid on December 18, 2018

Line Item 635 Structural Steel has a plan quantity of 2,717,000 lbs.

Bidding Index for Structural Steel (Category 2) in the proposal was \$46.72/CWT = BI

600,000 lbs. of Structural Steel for Structure 1 at Station 22+57.68 were shipped to fabricator from the producing mill in same month, August 2020.

Monthly Index for Structural Steel (Category 2) for August 2020 was \$27.03/CWT = MI

The Steel Price Adjustment formula is as follows:

$$\text{SPA} = ((\text{MI} / \text{BI}) - 1) * \text{BI} * (\text{Q} / 100)$$

Where; SPA = Steel price adjustment in dollars

BI = Bidding Index – in dollars (\$) per hundredweight (CWT). Use the adjustment indices as listed in the proposal.

MI = Mill Shipping Index – in dollars (\$) per hundredweight (CWT). Use the adjustment indices from the month the steel was shipped from the producing mill, received on the project, or member cast as defined in the Product Relationship Table.

Q = Quantity of steel product, in pounds (lbs.) actually incorporated into the work as documented by the Contractor, or Design Build Team and verified by the Engineer.

$$\text{BI} = \$46.72 / \text{CWT}$$

$$\text{MI} = \$27.03 / \text{CWT}$$

$$\% \text{ change} = ((\text{MI} / \text{BI}) - 1) = (\$27.03 / \$46.72 - 1) = (0.57855 - 1) = -0.421446917808$$

$$\text{Q} = 600,000 \text{ lbs.}$$

$$\text{SPA} = -0.421446917808 * \$46.72 * (600,000 / 100)$$

$$\text{SPA} = -0.421446917808 * \$46.72 * 6,000$$

$$\text{SPA} = \$ 118,140.00 \text{ Credit to the Department for Structural Steel (Structure 1 at Station 22+57.68)}$$

Price Adjustment Sample Calculation (increase)

Project bid on July 16, 2020

Line Item 614 Reinforced Concrete Deck Slab has a plan quantity of 241974 lbs.

Bidding Index Reference Month was May 2020. Bidding Index for Reinforced Concrete Deck Slab (Category 1) in the proposal was \$29.21/CWT = BI

51,621 lbs. of reinforcing steel and 52,311 lbs. of epoxy coated reinforcing steel for Structure 2 at Station 107+45.55 -L- was shipped to fabricator from the producing mill in same month, May 2021.

Monthly Index for Reinforced Concrete Deck Slab (Category 1) for May 2021 was \$43.13/CWT = MI

The Steel Price Adjustment formula is as follows:

$$\text{SPA} = ((\text{MI} / \text{BI}) - 1) * \text{BI} * (\text{Q} / 100)$$

Where; SPA = Steel price adjustment in dollars

BI = Bidding Index – in dollars (\$) per hundredweight (CWT). Use the adjustment indices as listed in the proposal.

MI = Mill Shipping Index – in dollars (\$) per hundredweight (CWT). Use the adjustment indices from the month the steel was shipped from the producing mill, received on the project, or member cast as defined in the Product Relationship Table.

Q = Quantity of steel product, in pounds (lbs.) actually incorporated into the work as documented by the Contractor, or Design Build Team and verified by the Engineer.

$$\text{BI} = \$29.21 / \text{CWT}$$

$$\text{MI} = \$43.13 / \text{CWT}$$

$$\% \text{ change} = ((\text{MI} / \text{BI}) - 1) = (\$43.13 / \$29.21 - 1) = (1.47655 - 1) = 0.47654912701$$

$$\text{Q} = 103932 \text{ lbs.}$$

$$\text{SPA} = 0.47654912701 * \$29.21 * (103,932 / 100)$$

$$\text{SPA} = 0.47654912701 * \$29.21 * 1,039.32$$

SPA = \$14,467.33 Pay Adjustment to Contractor for Reinforced Concrete Deck Slab (Category 1) at Station 107+45.55 -L-

SCHEDULE OF ESTIMATED COMPLETION PROGRESS:

(7-15-08) (Rev. 6-20-23)

108-2

SP1 G58

The Contractor's attention is directed to the Standard Special Provision entitled *Availability of Funds Termination of Contracts* included elsewhere in this proposal. The Department of Transportation's schedule of estimated completion progress for this project as required by that Standard Special Provision is as follows:

<u>Fiscal Year</u>	<u>Progress (% of Dollar Value)</u>
2024	(7/01/23 - 6/30/24) 25% of Total Amount Bid
2025	(7/01/24 - 6/30/25) 40% of Total Amount Bid
2026	(7/01/25 - 6/30/26) 31% of Total Amount Bid
2027	(7/01/26 - 6/30/27) 4% of Total Amount Bid

The Contractor shall also furnish his own progress schedule in accordance with Article 108-2 of the *2018 Standard Specifications*. Any acceleration of the progress as shown by the Contractor's progress schedule over the progress as shown above shall be subject to the approval of the Engineer.

MINORITY BUSINESS ENTERPRISE AND WOMEN BUSINESS ENTERPRISE:

(10-16-07)(Rev. 8-17-21)

102-15(J)

SP1 G66

Description

The purpose of this Special Provision is to carry out the North Carolina Department of Transportation's policy of ensuring nondiscrimination in the award and administration of contracts financed in whole or in part with State funds.

Definitions

Additional MBE/WBE Subcontractors - Any MBE/WBE submitted at the time of bid that will not be used to meet the Combined MBE /WBE Goal. No submittal of a Letter of Intent is required.

Combined MBE/WBE Goal: A portion of the total contract, expressed as a percentage that is to be performed by committed MBE/WBE subcontractors.

Committed MBE/WBE Subcontractor - Any MBE/WBE submitted at the time of bid that is being used to meet the Combined MBE /WBE goal by submission of a Letter of Intent. Or any MBE or WBE used as a replacement for a previously committed MBE or WBE firm.

Contract Goal Requirement - The approved participation at time of award, but not greater than the advertised Combined MBE/WBE contract goal.

Goal Confirmation Letter - Written documentation from the Department to the bidder confirming the Contractor's approved, committed participation along with a listing of the committed MBE and WBE firms.

Manufacturer - A firm that operates or maintains a factory or establishment that produces on the premises, the materials or supplies obtained by the Contractor.

MBE Participation (Anticipated) - A portion of the total contract, expressed as a percentage that is anticipated to be performed by committed MBE subcontractor(s).

Minority Business Enterprise (MBE) - A firm certified as a Disadvantaged Minority-Owned Business Enterprise through the North Carolina Unified Certification Program.

Regular Dealer - A firm that owns, operates, or maintains a store, warehouse, or other establishment in which the materials or supplies required for the performance of the contract are bought, kept in stock, and regularly sold to the public in the usual course of business. A regular dealer engages in, as its principal business and in its own name, the purchase and sale or lease of the products in question. A regular dealer in such bulk items as steel, cement, gravel, stone, and petroleum products need not keep such products in stock, if it owns and operates distribution equipment for the products. Brokers and packagers are not regarded as manufacturers or regular dealers within the meaning of this section.

Replacement / Substitution – A full or partial reduction in the amount of work subcontracted to a committed (or an approved substitute) MBE/WBE firm.

North Carolina Unified Certification Program (NCUCP) - A program that provides comprehensive services and information to applicants for MBE/WBE certification. The MBE/WBE program follows the same regulations as the federal Disadvantaged Business Enterprise (DBE) program in accordance with 49 CFR Part 26.

United States Department of Transportation (USDOT) - Federal agency responsible for issuing regulations (49 CFR Part 26) and official guidance for the DBE program.

WBE Participation (Anticipated) - A portion of the total contract, expressed as a percentage, that is anticipated to be performed by committed WBE subcontractor(s).

Women Business Enterprise (WBE) - A firm certified as a Disadvantaged Women-Owned Business Enterprise through the North Carolina Unified Certification Program.

Forms and Websites Referenced in this Provision

Payment Tracking System - On-line system in which the Contractor enters the payments made to MBE and WBE subcontractors who have performed work on the project.
<https://apps.dot.state.nc.us/Vendor/PaymentTracking/>

DBE-IS Subcontractor Payment Information - Form for reporting the payments made to all MBE/WBE firms working on the project. This form is for paper bid projects only.
<https://connect.ncdot.gov/business/Turnpike/Documents/Form%20DBE-IS%20Subcontractor%20Payment%20Information.pdf>

RF-1 MBE/WBE Replacement Request Form - Form for replacing a committed MBE or WBE.

<http://connect.ncdot.gov/projects/construction/Construction%20Forms/DBE%20MBE%20WBE%20Replacement%20Request%20Form.pdf>

SAF Subcontract Approval Form - Form required for approval to sublet the contract.

<http://connect.ncdot.gov/projects/construction/Construction%20Forms/Subcontract%20Approval%20Form%20Rev.%202012.zip>

JC-1 Joint Check Notification Form - Form and procedures for joint check notification. The form acts as a written joint check agreement among the parties providing full and prompt disclosure of the expected use of joint checks.

<http://connect.ncdot.gov/projects/construction/Construction%20Forms/Joint%20Check%20Notification%20Form.pdf>

Letter of Intent - Form signed by the Contractor and the MBE/WBE subcontractor, manufacturer or regular dealer that affirms that a portion of said contract is going to be performed by the signed MBE/WBE for the estimated amount (based on quantities and unit prices) listed at the time of bid.

<http://connect.ncdot.gov/letting/LetCentral/Letter%20of%20Intent%20to%20Perform%20as%20a%20Subcontractor.pdf>

Listing of MBE and WBE Subcontractors Form - Form for entering MBE/WBE subcontractors on a project that will meet the Combined MBE/WBE goal. This form is for paper bids only.

[http://connect.ncdot.gov/municipalities/Bid%20Proposals%20for%20LGA%20Content/09%20MBE-WBE%20Subcontractors%20\(State\).docx](http://connect.ncdot.gov/municipalities/Bid%20Proposals%20for%20LGA%20Content/09%20MBE-WBE%20Subcontractors%20(State).docx)

Subcontractor Quote Comparison Sheet - Spreadsheet for showing all subcontractor quotes in the work areas where MBEs and WBEs quoted on the project. This sheet is submitted with good faith effort packages.

<http://connect.ncdot.gov/business/SmallBusiness/Documents/DBE%20Subcontractor%20Quote%20Comparison%20Example.xls>

Combined MBE/WBE Goal

The Combined MBE/WBE Goal for this project is **6.0 %**

The Combined Goal was established utilizing the following anticipated participation for Minority Business Enterprises and Women Business Enterprises:

(A) Minority Business Enterprises **3.0 %**

- (1) *If the anticipated MBE participation is more than zero*, the Contractor shall exercise all necessary and reasonable steps to ensure that MBEs participate in at least the percent of the contract as set forth above.
- (2) *If the anticipated MBE participation is zero*, the Contractor shall make an effort to recruit and use MBEs during the performance of the contract. Any MBE participation obtained shall be reported to the Department.

(B) Women Business Enterprises **3.0 %**

- (1) *If the anticipated WBE participation is more than zero*, the Contractor shall exercise all necessary and reasonable steps to ensure that WBEs participate in at least the percent of the contract as set forth above.
- (2) *If the anticipated WBE participation is zero*, the Contractor shall make an effort to recruit and use WBEs during the performance of the contract. Any WBE participation obtained shall be reported to the Department.

The Bidder is required to submit only participation to meet the Combined MBE/WBE Goal. The Combined Goal may be met by submitting all MBE participation, all WBE participation, or a combination of MBE and WBE participation.

Directory of Transportation Firms (Directory)

Real-time information is available about firms doing business with the Department and firms that are certified through NCUCP in the Directory of Transportation Firms. Only firms identified in the Directory as MBE and WBE certified shall be used to meet the Combined MBE/WBE Goal. The Directory can be found at the following link.

<https://www.ebs.nc.gov/VendorDirectory/default.html>

The listing of an individual firm in the directory shall not be construed as an endorsement of the firm's capability to perform certain work.

Listing of MBE/WBE Subcontractors

At the time of bid, bidders shall submit all MBE and WBE participation that they anticipate to use during the life of the contract. Only those identified to meet the Combined MBE/WBE Goal will be considered committed, even though the listing shall include both committed MBE/WBE subcontractors and additional MBE/WBE subcontractors. Any additional MBE/WBE subcontractor participation above the goal will follow the banking guidelines found elsewhere in this provision. All other additional MBE/WBE subcontractor participation submitted at the time of bid will be used toward the Department's overall race-neutral goals. Only those firms with current MBE and WBE certification at the time of bid opening will be acceptable for listing in the bidder's submittal of MBE and WBE participation. The Contractor shall indicate the following required information:

(A) Electronic Bids

Bidders shall submit a listing of MBE and WBE participation in the appropriate section of the electronic submittal file.

- (1) Submit the names and addresses of MBE and WBE firms identified to participate in the contract. If the bidder uses the updated listing of MBE and WBE firms shown in the electronic submittal file, the bidder may use the dropdown menu to access the name and address of the firms.

- (2) Submit the contract line numbers of work to be performed by each MBE and WBE firm. When no figures or firms are entered, the bidder will be considered to have no MBE or WBE participation.
- (3) The bidder shall be responsible for ensuring that the MBE and WBE are certified at the time of bid by checking the Directory of Transportation Firms. If the firm is not certified at the time of the bid-letting, that MBE's or WBE's participation will not count towards achieving the Combined MBE/WBE goal.

(B) Paper Bids

- (1) *If the Combined MBE/WBE Goal is more than zero,*
 - (a) Bidders, at the time the bid proposal is submitted, shall submit a listing of MBE/WBE participation, including the names and addresses on *Listing of MBE and WBE Subcontractors* contained elsewhere in the contract documents in order for the bid to be considered responsive. Bidders shall indicate the total dollar value of the MBE and WBE participation for the contract.
 - (b) If bidders have no MBE or WBE participation, they shall indicate this on the *Listing of MBE and WBE Subcontractors* by entering the word "None" or the number "0." This form shall be completed in its entirety. **Blank forms will not be deemed to represent zero participation.** Bids submitted that do not have MBE and WBE participation indicated on the appropriate form will not be read publicly during the opening of bids. The Department will not consider these bids for award and the proposal will be rejected.
 - (c) The bidder shall be responsible for ensuring that the MBE/WBE is certified at the time of bid by checking the Directory of Transportation Firms. If the firm is not certified at the time of the bid-letting, that MBE's or WBE's participation will not count towards achieving the Combined MBE/WBE Goal.
- (2) *If the Combined MBE/WBE Goal is zero,* entries on the *Listing of MBE and WBE Subcontractors* are not required for the zero goal, however any MBE or WBE participation that is achieved during the project shall be reported in accordance with requirements contained elsewhere in the special provision.

MBE or WBE Prime Contractor

When a certified MBE or WBE firm bids on a contract that contains a Combined MBE/WBE goal, the firm is responsible for meeting the goal or making good faith efforts to meet the goal, just like any other bidder. In most cases, a MBE or WBE bidder on a contract will meet the Combined MBE/WBE Goal by virtue of the work it performs on the contract with its own forces. However, all the work that is performed by the MBE or WBE bidder and any other similarly certified

subcontractors will count toward the goal. The MBE or WBE bidder shall list itself along with any MBE or WBE subcontractors, if any, in order to receive credit toward the goal.

MBE/WBE prime contractors shall also follow Sections A and B listed under *Listing of MBE/WBE Subcontractor* just as a non-MBE/WBE bidder would.

Written Documentation – Letter of Intent

The bidder shall submit written documentation for each MBE/WBE that will be used to meet the Combined MBE/WBE Goal of the contract, indicating the bidder's commitment to use the MBE/WBE in the contract. This documentation shall be submitted on the Department's form titled *Letter of Intent*.

The documentation shall be received in the office of the State Contractor Utilization Engineer or at DBE@ncdot.gov no later than 10:00 a.m. of the sixth calendar day following opening of bids, unless the sixth day falls on an official state holiday. In that situation, it is due in the office of the State Contractor Utilization Engineer no later than 10:00 a.m. on the next official state business day.

If the bidder fails to submit the Letter of Intent from each committed MBE and WBE to be used toward the Combined MBE/WBE Goal, or if the form is incomplete (i.e. both signatures are not present), the MBE/WBE participation will not count toward meeting the Combined MBE/WBE Goal. If the lack of this participation drops the commitment below the Combined MBE/WBE Goal, the Contractor shall submit evidence of good faith efforts for the goal, completed in its entirety, to the State Contractor Utilization Engineer or DBE@ncdot.gov no later than 10:00 a.m. on the eighth calendar day following opening of bids, unless the eighth day falls on an official state holiday. In that situation, it is due in the office of the State Contractor Utilization Engineer no later than 10:00 a.m. on the next official state business day.

Banking MBE/WBE Credit

If the bid of the lowest responsive bidder exceeds \$500,000 and if the committed MBE/WBE participation submitted exceeds the algebraic sum of the Combined MBE /WBE Goal by \$1,000 or more, the excess will be placed on deposit by the Department for future use by the bidder. Separate accounts will be maintained for MBE and WBE participation and these may accumulate for a period not to exceed 24 months.

When the apparent lowest responsive bidder fails to submit sufficient participation by MBE and WBE firms to meet the advertised goal, as part of the good faith effort, the Department will consider allowing the bidder to withdraw funds to meet the Combined MBE/WBE Goal as long as there are adequate funds available from the bidder's MBE and WBE bank accounts.

Submission of Good Faith Effort

If the bidder fails to meet or exceed the Combined MBE/WBE Goal, the apparent lowest responsive bidder shall submit to the Department documentation of adequate good faith efforts made to reach that specific goal.

A hard copy and an electronic copy of this information shall be received in the office of the State Contractor Utilization Engineer or at DBE@ncdot.gov no later than 10:00 a.m. on the sixth calendar day following opening of bids unless the sixth day falls on an official state holiday. In that situation, it would be due in the office of the State Contractor Utilization Engineer no later than 10:00 a.m. on the next official state business day. If the contractor cannot send the information electronically, then one complete set and 5 copies of this information shall be received under the same time constraints above.

Note: Where the information submitted includes repetitious solicitation letters, it will be acceptable to submit a representative letter along with a distribution list of the firms that were solicited. Documentation of MBE/WBE quotations shall be a part of the good faith effort submittal. This documentation may include written subcontractor quotations, telephone log notations of verbal quotations, or other types of quotation documentation.

Consideration of Good Faith Effort for Projects with a Combined MBE/WBE Goal More Than Zero

Adequate good faith efforts mean that the bidder took all necessary and reasonable steps to achieve the goal which, by their scope, intensity, and appropriateness, could reasonably be expected to obtain sufficient MBE/WBE participation. Adequate good faith efforts also mean that the bidder actively and aggressively sought MBE/WBE participation. Mere *pro forma* efforts are not considered good faith efforts.

The Department will consider the quality, quantity, and intensity of the different kinds of efforts a bidder has made. Listed below are examples of the types of actions a bidder will take in making a good faith effort to meet the goals and are not intended to be exclusive or exhaustive, nor is it intended to be a mandatory checklist.

- (A) Soliciting through all reasonable and available means (e.g. attendance at pre-bid meetings, advertising, written notices, use of verifiable electronic means through the use of the NCDOT Directory of Transportation Firms) the interest of all certified MBEs/WBEs that are also prequalified subcontractors. The bidder must solicit this interest within at least 10 days prior to bid opening to allow the MBEs/WBEs to respond to the solicitation. Solicitation shall provide the opportunity to MBEs/WBEs within the Division and surrounding Divisions where the project is located. The bidder must determine with certainty if the MBEs/WBEs are interested by taking appropriate steps to follow up initial solicitations.
- (B) Selecting portions of the work to be performed by MBEs/WBEs in order to increase the likelihood that the Combined MBE/WBE Goal will be achieved.
 - (1) Where appropriate, break out contract work items into economically feasible units to facilitate MBE/WBE participation, even when the prime contractor might otherwise prefer to perform these work items with its own forces.
 - (2) Negotiate with subcontractors to assume part of the responsibility to meet the advertised goal when the work to be sublet includes potential for MBE/WBE participation (2nd and 3rd tier subcontractors).

- (C) Providing interested certified MBEs/WBEs that are also prequalified subcontractors with adequate information about the plans, specifications, and requirements of the contract in a timely manner to assist them in responding to a solicitation.
- (D)
 - (1) Negotiating in good faith with interested MBEs/WBEs. It is the bidder's responsibility to make a portion of the work available to MBE/WBE subcontractors and suppliers and to select those portions of the work or material needs consistent with the available MBE/WBE subcontractors and suppliers, so as to facilitate MBE/WBE participation. Evidence of such negotiation includes the names, addresses, and telephone numbers of MBEs/WBEs that were considered; a description of the information provided regarding the plans and specifications for the work selected for subcontracting; and evidence as to why additional agreements could not be reached for MBEs/WBEs to perform the work.
 - (2) A bidder using good business judgment would consider a number of factors in negotiating with subcontractors, including MBE/WBE subcontractors, and would take a firm's price and capabilities as well as the advertised goal into consideration. However, the fact that there may be some additional costs involved in finding and using MBEs/WBEs is not in itself sufficient reason for a bidder's failure to meet the contract goal, as long as such costs are reasonable. Also, the ability or desire of a prime contractor to perform the work of a contract with its own organization does not relieve the bidder of the responsibility to make good faith efforts. Bidding contractors are not, however, required to accept higher quotes from MBEs/WBEs if the price difference is excessive or unreasonable.
- (E) Not rejecting MBEs/WBEs as being unqualified without sound reasons based on a thorough investigation of their capabilities. The bidder's standing within its industry, membership in specific groups, organizations, or associates and political or social affiliations (for example, union vs. non-union employee status) are not legitimate causes for the rejection or non-solicitation of bids in the bidder's efforts to meet the project goal.
- (F) Making efforts to assist interested MBEs/WBEs in obtaining bonding, lines of credit, or insurance as required by the recipient or bidder.
- (G) Making efforts to assist interested MBEs/WBEs in obtaining necessary equipment, supplies, materials, or related assistance or services.
- (H) Effectively using the services of available minority/women community organizations; minority/women contractors' groups; Federal, State, and local minority/women business assistance offices; and other organizations as allowed on a case-by-case basis to provide assistance in the recruitment and placement of MBEs/WBEs. Contact within 7 days from the bid opening the Business Opportunity and Work Force Development Unit at BOWD@ncdot.gov to give notification of the bidder's inability to get MBE or WBE quotes.
- (I) Any other evidence that the bidder submits which shows that the bidder has made reasonable good faith efforts to meet the advertised goal.

In addition, the Department may take into account the following:

- (1) Whether the bidder's documentation reflects a clear and realistic plan for achieving the Combined MBE/WBE Goal.
- (2) The bidders' past performance in meeting the contract goal.
- (3) The performance of other bidders in meeting the advertised goal. For example, when the apparent successful bidder fails to meet the goal, but others meet it, you may reasonably raise the question of whether, with additional reasonable efforts the apparent successful bidder could have met the goal. If the apparent successful bidder fails to meet the advertised goal, but meets or exceeds the average MBE and WBE participation obtained by other bidders, the Department may view this, in conjunction with other factors, as evidence of the apparent successful bidder having made a good faith effort.

If the Department does not award the contract to the apparent lowest responsive bidder, the Department reserves the right to award the contract to the next lowest responsive bidder that can satisfy to the Department that the Combined MBE/WBE Goal can be met or that an adequate good faith effort has been made to meet the advertised goal.

Non-Good Faith Appeal

The State Prequalification Engineer will notify the contractor verbally and in writing of non-good faith. A contractor may appeal a determination of non-good faith made by the Goal Compliance Committee. If a contractor wishes to appeal the determination made by the Committee, they shall provide written notification to the State Prequalification Engineer or at DBE@ncdot.gov. The appeal shall be made within 2 business days of notification of the determination of non-good faith.

Counting MBE/WBE Participation Toward Meeting the Combined MBE/WBE Goal

(A) Participation

The total dollar value of the participation by a committed MBE/WBE will be counted toward the contract goal requirements. The total dollar value of participation by a committed MBE/WBE will be based upon the value of work actually performed by the MBE/WBE and the actual payments to MBE/WBE firms by the Contractor.

(B) Joint Checks

Prior notification of joint check use shall be required when counting MBE/WBE participation for services or purchases that involves the use of a joint check. Notification shall be through submission of Form JC-1 (*Joint Check Notification Form*) and the use of joint checks shall be in accordance with the Department's Joint Check Procedures.

(C) Subcontracts (Non-Trucking)

A MBE/WBE may enter into subcontracts. Work that a MBE subcontracts to another MBE firm may be counted toward the anticipated MBE participation. The same holds true for work that a WBE subcontracts to another WBE firm. Work that a MBE/WBE subcontracts to a non-MBE/WBE firm does not count toward the contract goal requirement. It should be noted that every effort shall be made by MBE and WBE contractors to subcontract to the same certification (i.e., MBEs to MBEs and WBEs to WBEs), in order to fulfill the MBE or WBE participation breakdown. This, however, may not always be possible due to the limitation of firms in the area. If the MBE or WBE firm shows a good faith effort has been made to reach out to similarly certified firms and there is no interest or availability, and they can get assistance from other certified firms, the Engineer will not hold the prime responsible for meeting the individual MBE or WBE breakdown. If a MBE or WBE contractor or subcontractor subcontracts a significantly greater portion of the work of the contract than would be expected on the basis of standard industry practices, it shall be presumed that the MBE or WBE is not performing a commercially useful function.

(D) Joint Venture

When a MBE or WBE performs as a participant in a joint venture, the Contractor may count toward its contract goal requirement a portion of the total value of participation with the MBE or WBE in the joint venture, that portion of the total dollar value being a distinct clearly defined portion of work that the MBE or WBE performs with its forces.

(E) Suppliers

A contractor may count toward its MBE/ WBE requirement 60 percent of its expenditures for materials and supplies required to complete the contract and obtained from a MBE or WBE regular dealer and 100 percent of such expenditures from a MBE or WBE manufacturer.

(F) Manufacturers and Regular Dealers

A contractor may count toward its MBE/ WBE requirement the following expenditures to MBE/WBE firms that are not manufacturers or regular dealers:

- (1) The fees or commissions charged by a MBE/WBE firm for providing a *bona fide* service, such as professional, technical, consultant, or managerial services, or for providing bonds or insurance specifically required for the performance of a DOT-assisted contract, provided the fees or commissions are determined to be reasonable and not excessive as compared with fees and commissions customarily allowed for similar services.
- (2) With respect to materials or supplies purchased from a MBE/WBE, which is neither a manufacturer nor a regular dealer, count the entire amount of fees or commissions charged for assistance in the procurement of the materials and supplies, or fees or transportation charges for the delivery of materials or supplies required on a job site (but not the cost of the materials and supplies themselves), provided the fees are

determined to be reasonable and not excessive as compared with fees customarily allowed for similar services.

Commercially Useful Function

(A) MBE/WBE Utilization

The Contractor may count toward its contract goal requirement only expenditures to MBEs and WBEs that perform a commercially useful function in the work of a contract. A MBE/WBE performs a commercially useful function when it is responsible for execution of the work of the contract and is carrying out its responsibilities by actually performing, managing, and supervising the work involved. To perform a commercially useful function, the MBE/WBE shall also be responsible with respect to materials and supplies used on the contract, for negotiating price, determining quality and quantity, ordering the material and installing (where applicable) and paying for the material itself. To determine whether a MBE/WBE is performing a commercially useful function, the Department will evaluate the amount of work subcontracted, industry practices, whether the amount the firm is to be paid under the contract is commensurate with the work it is actually performing and the MBE/WBE credit claimed for its performance of the work, and any other relevant factors. If it is determined that a MBE or WBE is not performing a Commercially Useful Function, the contractor may present evidence to rebut this presumption to the Department.

(B) MBE/WBE Utilization in Trucking

The following factors will be used to determine if a MBE or WBE trucking firm is performing a commercially useful function:

- (1) The MBE/WBE shall be responsible for the management and supervision of the entire trucking operation for which it is responsible on a particular contract, and there shall not be a contrived arrangement for the purpose of meeting the Combined MBE/WBE Goal.
- (2) The MBE/WBE shall itself own and operate at least one fully licensed, insured, and operational truck used on the contract.
- (3) The MBE/WBE receives credit for the total value of the transportation services it provides on the contract using trucks it owns, insures, and operates using drivers it employs.
- (4) The MBE may subcontract the work to another MBE firm, including an owner-operator who is certified as a MBE. The same holds true that a WBE may subcontract the work to another WBE firm, including an owner-operator who is certified as a WBE. When this occurs, the MBE or WBE who subcontracts work receives credit for the total value of the transportation services the subcontracted MBE or WBE provides on the contract. It should be noted that every effort shall be made by MBE and WBE contractors to subcontract to the same certification (i.e.,

MBEs to MBEs and WBEs to WBEs), in order to fulfill the participation breakdown. This, however, may not always be possible due to the limitation of firms in the area. If the MBE or WBE firm shows a good faith effort has been made to reach out to similarly certified transportation service providers and there is no interest or availability, and they can get assistance from other certified providers, the Engineer will not hold the prime responsible for meeting the individual MBE or WBE participation breakdown.

- (5) The MBE/WBE may also subcontract the work to a non-MBE/WBE firm, including from an owner-operator. The MBE/WBE who subcontracts the work to a non-MBE/WBE is entitled to credit for the total value of transportation services provided by the non-MBE/WBE subcontractor not to exceed the value of transportation services provided by MBE/WBE-owned trucks on the contract. Additional participation by non-MBE/WBE subcontractors receives credit only for the fee or commission it receives as a result of the subcontract arrangement. The value of services performed under subcontract agreements between the MBE/WBE and the Contractor will not count towards the MBE/WBE contract requirement.
- (6) A MBE/WBE may lease truck(s) from an established equipment leasing business open to the general public. The lease must indicate that the MBE/WBE has exclusive use of and control over the truck. This requirement does not preclude the leased truck from working for others during the term of the lease with the consent of the MBE/WBE, so long as the lease gives the MBE/WBE absolute priority for use of the leased truck. This type of lease may count toward the MBE/WBE's credit as long as the driver is under the MBE/WBE's payroll.
- (7) Subcontracted/leased trucks shall display clearly on the dashboard the name of the MBE/WBE that they are subcontracted/leased to and their own company name if it is not identified on the truck itself. Magnetic door signs are not permitted.

MBE/WBE Replacement

When a Contractor has relied on a commitment to a MBE or WBE subcontractor (or an approved substitute MBE or WBE subcontractor) to meet all or part of a contract goal requirement, the contractor shall not terminate the MBE/WBE subcontractor for convenience. This includes, but is not limited to, instances in which the Contractor seeks to perform the work of the terminated subcontractor with another MBE/WBE subcontractor, a non-MBE/WBE subcontractor, or with the Contractor's own forces or those of an affiliate.

The Contractor must give notice in writing both by certified mail and email to the MBE/WBE subcontractor, with a copy to the Engineer of its intent to request to terminate and/or substitute, and the reason for the request. The Contractor must give the MBE/WBE subcontractor five (5) business days to respond to the Contractor's Notice of Intent to Request Termination and/or Substitution. If the MBE/WBE subcontractor objects to the intended termination/substitution, the MBE/WBE, within five (5) business days must advise the Contractor and the Department of the reasons why the action should not be approved. The five-day notice period shall begin on the next business day after written notice is provided to the MBE/WBE subcontractor.

A committed MBE/WBE subcontractor may only be terminated after receiving the Department's written approval based upon a finding of good cause for the proposed termination and/or substitution. For purposes of this section, good cause shall include the following circumstances:

- (a) The listed MBE/WBE subcontractor fails or refuses to execute a written contract;
- (b) The listed MBE/WBE subcontractor fails or refuses to perform the work of its subcontract in a way consistent with normal industry standards. Provided, however, that good cause does not exist if the failure or refusal of the MBE/WBE subcontractor to perform its work on the subcontract results from the bad faith or discriminatory action of the prime contractor;
- (c) The listed MBE/WBE subcontractor fails or refuses to meet the prime contractor's reasonable, nondiscriminatory bond requirements;
- (d) The listed MBE/WBE subcontractor becomes bankrupt, insolvent, or exhibits credit unworthiness;
- (e) The listed MBE/WBE subcontractor is ineligible to work on public works projects because of suspension and debarment proceedings pursuant to 2 CFR Parts 180, 215 and 1,200 or applicable state law;
- (f) The listed MBE/WBE subcontractor is not a responsible contractor;
- (g) The listed MBE/WBE voluntarily withdraws from the project and provides written notice of withdrawal;
- (h) The listed MBE/WBE is ineligible to receive MBE/WBE credit for the type of work required;
- (i) A MBE/WBE owner dies or becomes disabled with the result that the listed MBE/WBE contractor is unable to complete its work on the contract;
- (j) Other documented good cause that compels the termination of the MBE/WBE subcontractor. Provided, that good cause does not exist if the prime contractor seeks to terminate a MBE/WBE it relied upon to obtain the contract so that the prime contractor can self-perform the work for which the MBE/WBE contractor was engaged or so that the prime contractor can substitute another MBE/WBE or non-MBE/WBE contractor after contract award.

The Contractor shall comply with the following for replacement of a committed MBE/WBE:

(A) Performance Related Replacement

When a committed MBE/WBE is terminated for good cause as stated above, an additional MBE/WBE that was submitted at the time of bid may be used to fulfill the MBE/WBE commitment to meet the Combined MBE/WBE Goal. A good faith effort will only be required for removing a committed MBE/WBE if there were no additional MBE/WBEs submitted at the time of bid to cover the same amount of work as the MBE/WBE that was terminated.

If a replacement MBE/WBE is not found that can perform at least the same amount of work as the terminated MBE/WBE, the Contractor shall submit a good faith effort documenting the steps taken. Such documentation shall include, but not be limited to, the following:

- (1) Copies of written notification to MBE/WBEs that their interest is solicited in contracting the work defaulted by the previous MBE/WBE or in subcontracting other items of work in the contract.
- (2) Efforts to negotiate with MBE/WBEs for specific subbids including, at a minimum:

- (a) The names, addresses, and telephone numbers of MBE/WBEs who were contacted.
 - (b) A description of the information provided to MBE/WBEs regarding the plans and specifications for portions of the work to be performed.
- (3) A list of reasons why MBE/WBE quotes were not accepted.
 - (4) Efforts made to assist the MBE/WBEs contacted, if needed, in obtaining bonding or insurance required by the Contractor.
- (B) Decertification Replacement
- (1) When a committed MBE/WBE is decertified by the Department after the SAF (*Subcontract Approval Form*) has been received by the Department, the Department will not require the Contractor to solicit replacement MBE/WBE participation equal to the remaining work to be performed by the decertified firm. The participation equal to the remaining work performed by the decertified firm will count toward the contract goal requirement.
 - (2) When a committed MBE/WBE is decertified prior to the Department receiving the SAF (*Subcontract Approval Form*) for the named MBE/WBE firm, the Contractor shall take all necessary and reasonable steps to replace the MBE/WBE subcontractor with another MBE/WBE subcontractor to perform at least the same amount of work to meet the Combined MBE/WBE goal requirement. If a MBE/WBE firm is not found to do the same amount of work, a good faith effort must be submitted to NCDOT (see A herein for required documentation).
 - (3) Exception: If the MBE/WBE's ineligibility is caused solely by its having exceeded the size standard during the performance of the contract, the Department will not require the Contractor to solicit replacement MBE/WBE participation equal to the remaining work to be performed by the decertified firm. The participation equal to the remaining work performed by the decertified firm will count toward the contract goal requirement and overall goal.

All requests for replacement of a committed MBE/WBE firm shall be submitted to the Engineer for approval on Form RF-1 (*DBE Replacement Request*). If the Contractor fails to follow this procedure, the Contractor may be disqualified from further bidding for a period of up to 6 months.

Changes in the Work

When the Engineer makes changes that result in the reduction or elimination of work to be performed by a committed MBE/WBE, the Contractor will not be required to seek additional participation. When the Engineer makes changes that result in additional work to be performed by a MBE/WBE based upon the Contractor's commitment, the MBE/WBE shall participate in additional work to the same extent as the MBE/WBE participated in the original contract work.

When the Engineer makes changes that result in extra work, which has more than a minimal impact on the contract amount, the Contractor shall seek additional participation by MBEs/WBEs unless otherwise approved by the Engineer.

When the Engineer makes changes that result in an alteration of plans or details of construction, and a portion or all of the work had been expected to be performed by a committed MBE/WBE, the Contractor shall seek participation by MBEs/WBEs unless otherwise approved by the Engineer.

When the Contractor requests changes in the work that result in the reduction or elimination of work that the Contractor committed to be performed by a MBE/WBE, the Contractor shall seek additional participation by MBEs/WBEs equal to the reduced MBE/WBE participation caused by the changes.

Reports and Documentation

A SAF (*Subcontract Approval Form*) shall be submitted for all work which is to be performed by a MBE/WBE subcontractor. The Department reserves the right to require copies of actual subcontract agreements involving MBE/WBE subcontractors.

When using transportation services to meet the contract commitment, the Contractor shall submit a proposed trucking plan in addition to the SAF. The plan shall be submitted prior to beginning construction on the project. The plan shall include the names of all trucking firms proposed for use, their certification type(s), the number of trucks owned by the firm, as well as the individual truck identification numbers, and the line item(s) being performed.

Within 30 calendar days of entering into an agreement with a MBE/WBE for materials, supplies or services, not otherwise documented by the SAF as specified above, the Contractor shall furnish the Engineer a copy of the agreement. The documentation shall also indicate the percentage (60% or 100%) of expenditures claimed for MBE/WBE credit.

Reporting Minority and Women Business Enterprise Participation

The Contractor shall provide the Engineer with an accounting of payments made to all MBE/WBE firms, including material suppliers and contractors at all levels (prime, subcontractor, or second tier subcontractor). This accounting shall be furnished to the Engineer for any given month by the end of the following month. Failure to submit this information accordingly may result in the following action:

- (A) Withholding of money due in the next partial pay estimate; or
- (B) Removal of an approved contractor from the prequalified bidders' list or the removal of other entities from the approved subcontractors list.

While each contractor (prime, subcontractor, 2nd tier subcontractor) is responsible for accurate accounting of payments to MBEs/WBEs, it shall be the prime contractor's responsibility to report all monthly and final payment information in the correct reporting manner.

Failure on the part of the Contractor to submit the required information in the time frame specified may result in the disqualification of that contractor and any affiliate companies from further bidding until the required information is submitted.

Failure on the part of any subcontractor to submit the required information in the time frame specified may result in the disqualification of that contractor and any affiliate companies from being approved for work on future DOT projects until the required information is submitted.

Contractors reporting transportation services provided by non-MBE/WBE lessees shall evaluate the value of services provided during the month of the reporting period only.

At any time, the Engineer can request written verification of subcontractor payments.

The Contractor shall report the accounting of payments through the Department's Payment Tracking System.

Failure to Meet Contract Requirements

Failure to meet contract requirements in accordance with Subarticle 102-15(J) of the *2018 Standard Specifications* may be cause to disqualify the Contractor.

CONTRACTOR'S LICENSE REQUIREMENTS:

(7-1-95)

102-14

SP1 G88

If the successful bidder does not hold the proper license to perform any plumbing, heating, air conditioning, or electrical work in this contract, he will be required to sublet such work to a contractor properly licensed in accordance with *Article 2 of Chapter 87 of the General Statutes* (licensing of heating, plumbing, and air conditioning contractors) and *Article 4 of Chapter 87 of the General Statutes* (licensing of electrical contractors).

RESTRICTIONS ON ITS EQUIPMENT AND SERVICES:

(11-17-20)

SP01 G090

All telecommunications, video or other ITS equipment or services installed or utilized on this project must be in conformance with UNIFORM ADMINISTRATIVE REQUIREMENTS, COST PRINCIPLES, AND AUDIT REQUIREMENTS FOR FEDERAL AWARDS **2 CFR, § 200.216**
Prohibition on certain telecommunications and video surveillance services or equipment.

USE OF UNMANNED AIRCRAFT SYSTEM (UAS):

(8-20-19)

SP1 G092

The Contractor shall adhere to all Federal, State and Local regulations and guidelines for the use of Unmanned Aircraft Systems (UAS). This includes but is not limited to US 14 CFR Part 107 *Small UAS Rule*, NC GS 15A-300.2 *Regulation of launch and recovery sites*, NC GS 63-95 *Training required for the operation of unmanned aircraft systems*, NC GS 63-96 *Permit required for commercial operation of unmanned aircraft system*, and NCDOT UAS Policy. The required operator certifications include possessing a current Federal Aviation Administration (FAA) Remote Pilot Certificate, a NC UAS Operator Permit as well as operating a UAS registered with the FAA.

Prior to beginning operations, the Contractor shall complete the NCDOT UAS – Flight Operation Approval Form and submit it to the Engineer for approval. All UAS operations shall be approved by the Engineer prior to beginning the operations.

All contractors or subcontractors operating UAS shall have UAS specific general liability insurance to cover all operations under this contract.

The use of UAS is at the Contractor's discretion. No measurement or payment will be made for the use of UAS. In the event that the Department directs the Contractor to utilize UAS, payment will be in accordance with Article 104-7 Extra Work.

EQUIPMENT IDLING GUIDELINES:

(1-19-21)

107

SP1 G096

Exercise reduced fuel consumption and reduced equipment emissions during the construction of all work associated with this contract. Employees engaged in the construction of this project should turn off vehicles when stopped for more than thirty (30) minutes and off-highway equipment should idle no longer than fifteen (15) consecutive minutes.

These guidelines for turning off vehicles and equipment when idling do not apply to:

1. Idling when queuing.
2. Idling to verify the vehicle is in safe operating condition.
3. Idling for testing, servicing, repairing or diagnostic purposes.
4. Idling necessary to accomplish work for which the vehicle was designed (such as operating a crane, mixing concrete, etc.).
5. Idling required to bring the machine system to operating temperature.
6. Emergency vehicles, utility company, construction, and maintenance vehicles where the engines must run to perform needed work.
7. Idling to ensure safe operation of the vehicle.
8. Idling when the propulsion engine is providing auxiliary power for other than heating or air conditioning. (such as hydraulic systems for pavers)
9. When specific traffic, safety, or emergency situations arise.
10. If the ambient temperature is less than 32 degrees Fahrenheit. Limited idling to provide for the safety of vehicle occupants (e.g. to run the heater).
11. If the ambient temperature is greater than 90 degrees Fahrenheit. Limited idling to provide for the safety of vehicle occupants of off-highway equipment (e.g. to run the air conditioning) no more than 30 minutes.
12. Diesel powered vehicles may idle for up to 30 minutes to minimize restart problems.

Any vehicle, truck, or equipment in which the primary source of fuel is natural gas or electricity is exempt from the idling limitations set forth in this special provision.

SUBSURFACE INFORMATION:

(7-1-95)

450

SP1 G112 C

Subsurface information is available on the roadway and structure portions of this project.

MAINTENANCE OF THE PROJECT:

(11-20-07) (Rev. 1-17-12)

104-10

SP1 G125

Revise the *2018 Standard Specifications* as follows:

Page 1-39, Article 104-10 Maintenance of the Project, line 25, add the following after the first sentence of the first paragraph:

All guardrail/guiderail within the project limits shall be included in this maintenance.

Page 1-39, Article 104-10 Maintenance of the Project, line 30, add the following as the last sentence of the first paragraph:

The Contractor shall perform weekly inspections of guardrail and guiderail and shall report damages to the Engineer on the same day of the weekly inspection. *Where damaged guardrail or guiderail is repaired or replaced as a result of maintaining the project in accordance with this article, such repair or replacement shall be performed within 7 consecutive calendar days of such inspection report.*

Page 1-39, Article 104-10 Maintenance of the Project, lines 42-44, replace the last sentence of the last paragraph with the following:

The Contractor will not be directly compensated for any maintenance operations necessary, except for maintenance of guardrail/guiderail, as this work will be considered incidental to the work covered by the various contract items. The provisions of Article 104-7, Extra Work, and Article 104-8, Compensation and Record Keeping will apply to authorized maintenance of guardrail/guiderail. Performance of weekly inspections of guardrail/guiderail, and the damage reports required as described above, will be considered to be an incidental part of the work being paid for by the various contract items.

ELECTRONIC BIDDING:

(2-19-19)

101, 102, 103

SP1 G140

Revise the *2018 Standard Specifications* as follows:

Page 1-4, Article 101-3, DEFINITIONS, BID (OR PROPOSAL) *Electronic Bid*, line 1, replace “Bid Express®” with “the approved electronic bidding provider”.

Page 1-15, Subarticle 102-8(B), Electronic Bids, lines 39-40, replace “to Bid Express®” with “via the approved electronic bidding provider”.

Page 1-15, Subarticle 102-8(B)(1), Electronic Bids, line 41, delete “from Bid Express®”

Page 1-17, Subarticle 102-9(C)(2), Electronic Bids, line 21, replace “Bid Express® miscellaneous folder within the .ebs” with “electronic submittal”.

Page 1-29, Subarticle 103-4(C)(2), Electronic Bids, line 32, replace “.ebs miscellaneous data file of Expedite” with “electronic submittal file”

AWARD LIMITS:

(4-19-22)

103

SP1 G141

Revise the *2018 Standard Specifications* as follows:

Page 1-29, Subarticle 103-4(C), Award Limits, line 4-8, delete and replace the first sentence in the first paragraph with the following:

A bidder who desires to bid on more than one project on which bids are to be opened in the same letting and who desires to avoid receiving an award of more projects than he is equipped to handle, may bid on any number of projects but may limit the total amount of work awarded to him on selected projects by completing the form Award Limits on Multiple Projects for each project subject to the award limit.

TWELVE MONTH GUARANTEE:

(7-15-03)

108

SP1 G145

- (A) The Contractor shall guarantee materials and workmanship against latent and patent defects arising from faulty materials, faulty workmanship or negligence for a period of twelve months following the date of final acceptance of the work for maintenance and shall replace such defective materials and workmanship without cost to the Department. The Contractor will not be responsible for damage due to faulty design, normal wear and tear, for negligence on the part of the Department, and/or for use in excess of the design.
- (B) Where items of equipment or material carry a manufacturer's guarantee for any period in excess of twelve months, then the manufacturer's guarantee shall apply for that particular piece of equipment or material. The Department's first remedy shall be through the manufacturer although the Contractor is responsible for invoking the warranted repair work with the manufacturer. The Contractor's responsibility shall be limited to the term of the manufacturer's guarantee. NCDOT would be afforded the same warranty as provided by the Manufacturer.

This guarantee provision shall be invoked only for major components of work in which the Contractor would be wholly responsible for under the terms of the contract. Examples would include pavement structures, bridge components, and sign structures. This provision will not be used as a mechanism to force the Contractor to return to the project to make repairs or perform additional work that the Department would normally compensate the Contractor for. In addition, routine maintenance activities (i.e. mowing grass, debris removal, ruts in earth shoulders,) are not parts of this guarantee.

Appropriate provisions of the payment and/or performance bonds shall cover this guarantee for the project.

To ensure uniform application statewide the Division Engineer will forward details regarding the circumstances surrounding any proposed guarantee repairs to the Chief Engineer for review and approval prior to the work being performed.

OUTSOURCING OUTSIDE THE USA:

(9-21-04) (Rev. 5-16-06)

SP1 G150

All work on consultant contracts, services contracts, and construction contracts shall be performed in the United States of America. No work shall be outsourced outside of the United States of America.

Outsourcing for the purpose of this provision is defined as the practice of subcontracting labor, work, services, staffing, or personnel to entities located outside of the United States.

The North Carolina Secretary of Transportation shall approve exceptions to this provision in writing.

EROSION AND SEDIMENT CONTROL/STORMWATER CERTIFICATION:

(1-16-07) (Rev 12-15-20)

105-16, 225-2, 16

SP1 G180

General

Schedule and conduct construction activities in a manner that will minimize soil erosion and the resulting sedimentation and turbidity of surface waters. Comply with the requirements herein regardless of whether or not a National Pollution discharge Elimination System (NPDES) permit for the work is required.

Establish a chain of responsibility for operations and subcontractors' operations to ensure that the *Erosion and Sediment Control/Stormwater Pollution Prevention Plan* is implemented and maintained over the life of the contract.

- (A) *Certified Supervisor* - Provide a certified Erosion and Sediment Control/Stormwater Supervisor to manage the Contractor and subcontractor operations, insure compliance with Federal, State and Local ordinances and regulations, and manage the Quality Control Program.
- (B) *Certified Foreman* - Provide a certified, trained foreman for each construction operation that increases the potential for soil erosion or the possible sedimentation and turbidity of surface waters.
- (C) *Certified Installer* - Provide a certified installer to install or direct the installation for erosion or sediment/stormwater control practices.
- (D) *Certified Designer* - Provide a certified designer for the design of the erosion and sediment control/stormwater component of reclamation plans and, if applicable, for the design of the project erosion and sediment control/stormwater plan.

Roles and Responsibilities

- (A) *Certified Erosion and Sediment Control/Stormwater Supervisor* - The Certified Supervisor shall be Level II and responsible for ensuring the erosion and sediment control/stormwater plan is adequately implemented and maintained on the project and for conducting the quality control program. The Certified Supervisor shall be on the project within 24 hours

notice from initial exposure of an erodible surface to the project's final acceptance. Perform the following duties:

- (1) Manage Operations - Coordinate and schedule the work of subcontractors so that erosion and sediment control/stormwater measures are fully executed for each operation and in a timely manner over the duration of the contract.
 - (a) Oversee the work of subcontractors so that appropriate erosion and sediment control/stormwater preventive measures are conformed to at each stage of the work.
 - (b) Prepare the required National Pollutant Discharge Elimination System (NPDES) Inspection Record and submit to the Engineer.
 - (c) Attend all weekly or monthly construction meetings to discuss the findings of the NPDES inspection and other related issues.
 - (d) Implement the erosion and sediment control/stormwater site plans requested.
 - (e) Provide any needed erosion and sediment control/stormwater practices for the Contractor's temporary work not shown on the plans, such as, but not limited to work platforms, temporary construction, pumping operations, plant and storage yards, and cofferdams.
 - (f) Acquire applicable permits and comply with requirements for borrow pits, dewatering, and any temporary work conducted by the Contractor in jurisdictional areas.
 - (g) Conduct all erosion and sediment control/stormwater work in a timely and workmanlike manner.
 - (h) Fully perform and install erosion and sediment control/stormwater work prior to any suspension of the work.
 - (i) Coordinate with Department, Federal, State and Local Regulatory agencies on resolution of erosion and sediment control/stormwater issues due to the Contractor's operations.
 - (j) Ensure that proper cleanup occurs from vehicle tracking on paved surfaces or any location where sediment leaves the Right-of-Way.
 - (k) Have available a set of erosion and sediment control/stormwater plans that are initialed and include the installation date of Best Management Practices. These practices shall include temporary and permanent groundcover and be properly updated to reflect necessary plan and field changes for use and review by Department personnel as well as regulatory agencies.

- (2) Requirements set forth under the NPDES Permit - The Department's NPDES Stormwater permit (NCS000250) outlines certain objectives and management measures pertaining to construction activities. The permit references *NCG010000, General Permit to Discharge Stormwater* under the NPDES, and states that the Department shall incorporate the applicable requirements into its delegated Erosion and Sediment Control Program for construction activities disturbing one or more acres of land. The Department further incorporates these requirements on all contracted bridge and culvert work at jurisdictional waters, regardless of size. Some of the requirements are, but are not limited to:

- (a) Control project site waste to prevent contamination of surface or ground waters of the state, i.e. from equipment operation/maintenance, construction materials, concrete washout, chemicals, litter, fuels, lubricants, coolants, hydraulic fluids, any other petroleum products, and sanitary waste.
 - (b) Inspect erosion and sediment control/stormwater devices and stormwater discharge outfalls at least once every 7 calendar days and within 24 hours after a rainfall event equal to or greater than 1.0 inch that occurs within a 24 hour period. Additional monitoring may be required at the discretion of Division of Water Resources personnel if the receiving stream is 303(d) listed for turbidity and the project has had documented problems managing turbidity.
 - (c) Maintain an onsite rain gauge or use the Department's Multi-Sensor Precipitation Estimate website to maintain a daily record of rainfall amounts and dates.
 - (d) Maintain erosion and sediment control/stormwater inspection records for review by Department and Regulatory personnel upon request.
 - (e) Implement approved reclamation plans on all borrow pits, waste sites and staging areas.
 - (f) Maintain a log of turbidity test results as outlined in the Department's Procedure for Monitoring Borrow Pit Discharge.
 - (g) Provide secondary containment for bulk storage of liquid materials.
 - (h) Provide training for employees concerning general erosion and sediment control/stormwater awareness, the Department's NPDES Stormwater Permit NCS000250 requirements, and the applicable requirements of the *General Permit, NCG010000*.
 - (i) Report violations of the NPDES permit to the Engineer immediately who will notify the Division of Water Quality Regional Office within 24 hours of becoming aware of the violation.
- (3) Quality Control Program - Maintain a quality control program to control erosion, prevent sedimentation and follow provisions/conditions of permits. The quality control program shall:
- (a) Follow permit requirements related to the Contractor and subcontractors' construction activities.
 - (b) Ensure that all operators and subcontractors on site have the proper erosion and sediment control/stormwater certification.
 - (c) Notify the Engineer when the required certified erosion and sediment control/stormwater personnel are not available on the job site when needed.
 - (d) Conduct the inspections required by the NPDES permit.
 - (e) Take corrective actions in the proper timeframe as required by the NPDES permit for problem areas identified during the NPDES inspections.
 - (f) Incorporate erosion control into the work in a timely manner and stabilize disturbed areas with mulch/seed or vegetative cover on a section-by-section basis.
 - (g) Use flocculants approved by state regulatory authorities where appropriate and where required for turbidity and sedimentation reduction.

- (h) Ensure proper installation and maintenance of temporary erosion and sediment control devices.
- (i) Remove temporary erosion or sediment control devices when they are no longer necessary as agreed upon by the Engineer.
- (j) The Contractor's quality control and inspection procedures shall be subject to review by the Engineer. Maintain NPDES inspection records and make records available at all times for verification by the Engineer.

(B) *Certified Foreman* - At least one Certified Foreman shall be onsite for each type of work listed herein during the respective construction activities to control erosion, prevent sedimentation and follow permit provisions:

- (1) Foreman in charge of grading activities
- (2) Foreman in charge of bridge or culvert construction over jurisdictional areas
- (3) Foreman in charge of utility activities

The Contractor may request to use the same person as the Level II Supervisor and Level II Foreman. This person shall be onsite whenever construction activities as described above are taking place. This request shall be approved by the Engineer prior to work beginning.

The Contractor may request to name a single Level II Foreman to oversee multiple construction activities on small bridge or culvert replacement projects. This request shall be approved by the Engineer prior to work beginning.

(C) *Certified Installers* - Provide at least one onsite, Level I Certified Installer for each of the following erosion and sediment control/stormwater crew:

- (1) Seeding and Mulching
- (2) Temporary Seeding
- (3) Temporary Mulching
- (4) Sodding
- (5) Silt fence or other perimeter erosion/sediment control device installations
- (6) Erosion control blanket installation
- (7) Hydraulic tackifier installation
- (8) Turbidity curtain installation
- (9) Rock ditch check/sediment dam installation
- (10) Ditch liner/matting installation
- (11) Inlet protection
- (12) Riprap placement
- (13) Stormwater BMP installations (such as but not limited to level spreaders, retention/detention devices)
- (14) Pipe installations within jurisdictional areas

If a Level I *Certified Installer* is not onsite, the Contractor may substitute a Level II Foreman for a Level I Installer, provided the Level II Foreman is not tasked to another crew requiring Level II Foreman oversight.

- (D) *Certified Designer* - Include the certification number of the Level III Certified Designer on the erosion and sediment control/stormwater component of all reclamation plans and if applicable, the certification number of the Level III Certified Designer on the design of the project erosion and sediment control/stormwater plan.

Preconstruction Meeting

Furnish the names of the *Certified Erosion and Sediment Control/Stormwater Supervisor*, *Certified Foremen*, *Certified Installers* and *Certified Designer* and notify the Engineer of changes in certified personnel over the life of the contract within 2 days of change.

Ethical Responsibility

Any company performing work for the North Carolina Department of Transportation has the ethical responsibility to fully disclose any reprimand or dismissal of an employee resulting from improper testing or falsification of records.

Revocation or Suspension of Certification

Upon recommendation of the Chief Engineer to the certification entity, certification for *Supervisor*, *Certified Foremen*, *Certified Installers* and *Certified Designer* may be revoked or suspended with the issuance of an *Immediate Corrective Action (ICA)*, *Notice of Violation (NOV)*, or *Cease and Desist Order* for erosion and sediment control/stormwater related issues.

The Chief Engineer may recommend suspension or permanent revocation of certification due to the following:

- (A) Failure to adequately perform the duties as defined within this certification provision.
- (B) Issuance of an ICA, NOV, or Cease and Desist Order.
- (C) Failure to fully perform environmental commitments as detailed within the permit conditions and specifications.
- (D) Demonstration of erroneous documentation or reporting techniques.
- (E) Cheating or copying another candidate's work on an examination.
- (F) Intentional falsification of records.
- (G) Directing a subordinate under direct or indirect supervision to perform any of the above actions.
- (H) Dismissal from a company for any of the above reasons.
- (I) Suspension or revocation of one's certification by another entity.

Suspension or revocation of a certification will be sent by certified mail to the certificant and the Corporate Head of the company that employs the certificant.

A certificant has the right to appeal any adverse action which results in suspension or permanent revocation of certification by responding, in writing, to the Chief Engineer within 10 calendar days after receiving notice of the proposed adverse action.

Chief Engineer
1536 Mail Service Center
Raleigh, NC 27699-1536

Failure to appeal within 10 calendar days will result in the proposed adverse action becoming effective on the date specified on the certified notice. Failure to appeal within the time specified will result in a waiver of all future appeal rights regarding the adverse action taken. The certificant will not be allowed to perform duties associated with the certification during the appeal process.

The Chief Engineer will hear the appeal and make a decision within 7 days of hearing the appeal. Decision of the Chief Engineer will be final and will be made in writing to the certificant.

If a certification is temporarily suspended, the certificant shall pass any applicable written examination and any proficiency examination, at the conclusion of the specified suspension period, prior to having the certification reinstated.

Measurement and Payment

Certified Erosion and Sediment Control/Stormwater Supervisor, Certified Foremen, Certified Installers and Certified Designer will be incidental to the project for which no direct compensation will be made.

NOTE TO CONTRACTOR (MATERIAL ACQUISITION):

Material acquisition may commence upon execution of the Contract and any associated payments shall be completed in accordance with Section 109-5 of the Standard Specifications. Material acquisition has been considered during establishment of the date of availability listed in the Contract Time and Liquidated Damages provision.

PROCEDURE FOR MONITORING BORROW PIT DISCHARGE:

(2-20-07) (Rev. 4-5-19)

105-16, 230, 801

SP1 G181

Water discharge from borrow pit sites shall not cause surface waters to exceed 50 NTUs (nephelometric turbidity unit) in streams not designated as trout waters and 10 NTUs in streams, lakes or reservoirs designated as trout waters. For lakes and reservoirs not designated as trout waters, the turbidity shall not exceed 25 NTUs. If the turbidity exceeds these levels due to natural background conditions, the existing turbidity level shall not be increased.

If during any operating day, the downstream water quality exceeds the standard, the Contractor shall do all of the following:

- (A) Either cease discharge or modify the discharge volume or turbidity levels to bring the downstream turbidity levels into compliance, or
- (B) Evaluate the upstream conditions to determine if the exceedance of the standard is due to natural background conditions. If the background turbidity measurements exceed the standard, operation of the pit and discharge can continue as long as the stream turbidity levels are not increased due to the discharge.

- (C) Measure and record the turbidity test results (time, date and sampler) at all defined sampling locations 30 minutes after startup and at a minimum, one additional sampling of all sampling locations during that 24-hour period in which the borrow pit is discharging.
- (D) Notify DWQ within 24 hours of any stream turbidity standard exceedances that are not brought into compliance.

During the Environmental Assessment required by Article 230-4 of the *2018 Standard Specifications*, the Contractor shall define the point at which the discharge enters into the State's surface waters and the appropriate sampling locations. Sampling locations shall include points upstream and downstream from the point at which the discharge enters these waters. Upstream sampling location shall be located so that it is not influenced by backwater conditions and represents natural background conditions. Downstream sampling location shall be located at the point where complete mixing of the discharge and receiving water has occurred.

The discharge shall be closely monitored when water from the dewatering activities is introduced into jurisdictional wetlands. Any time visible sedimentation (deposition of sediment) on the wetland surface is observed, the dewatering activity will be suspended until turbidity levels in the stilling basin can be reduced to a level where sediment deposition does not occur. Staining of wetland surfaces from suspended clay particles, occurring after evaporation or infiltration, does not constitute sedimentation. No activities shall occur in wetlands that adversely affect the functioning of a wetland. Visible sedimentation will be considered an indication of possible adverse impacts on wetland use.

The Engineer will perform independent turbidity tests on a random basis. These results will be maintained in a log within the project records. Records will include, at a minimum, turbidity test results, time, date and name of sampler. Should the Department's test results exceed those of the Contractor's test results, an immediate test shall be performed jointly with the results superseding the previous test results of both the Department and the Contractor.

The Contractor shall use the *NCDOT Turbidity Reduction Options for Borrow Pits Matrix*, available at <https://connect.ncdot.gov/resources/roadside/FieldOperationsDocuments/TurbidityReductionOptionSheet.pdf> to plan, design, construct, and maintain BMPs to address water quality standards. Tier I Methods include stilling basins which are standard compensatory BMPs. Other Tier I methods are noncompensatory and shall be used when needed to meet the stream turbidity standards. Tier II Methods are also noncompensatory and are options that may be needed for protection of rare or unique resources or where special environmental conditions exist at the site which have led to additional requirements being placed in the DWQ's 401 Certifications and approval letters, Isolated Wetland Permits, Riparian Buffer Authorization or a DOT Reclamation Plan's Environmental Assessment for the specific site. Should the Contractor exhaust all Tier I Methods on a site exclusive of rare or unique resources or special environmental conditions, Tier II Methods may be required by regulators on a case by case basis per supplemental agreement.

The Contractor may use cation exchange capacity (CEC) values from proposed site borings to plan and develop the bid for the project. CEC values exceeding 15 milliequivalents per 100 grams of soil may indicate a high potential for turbidity and should be avoided when dewatering into surface water is proposed.

No additional compensation for monitoring borrow pit discharge will be paid.

PROJECT SPECIAL PROVISIONS**ROADWAY****CLEARING AND GRUBBING - METHOD II:**

(9-17-02) (Rev.8-18-15)

200

SP2 R02A

Perform clearing on this project to the limits established by Method "II" shown on Standard Drawing No. 200.02 of the *2018 Roadway Standard Drawings*. Conventional clearing methods may be used except where permit drawings or conditions have been included in the proposal which require certain areas to be cleared by hand methods.

LUMP SUM GRADING:

(8-17-10)(Rev. 12-20-22)

226

SP2 R16

Lump sum grading shall be performed in accordance with Section 226 Comprehensive Grading of the *2018 Standard Specifications* except as follows:

Delete all references to **Section 230 Borrow Excavation (Item 0106)**.

TEMPORARY PAVEMENT:

(8-15-00) (Rev. 4-21-15)

1101

SP2 R30A(Rev)

Construct the temporary pavement required on this project in accordance with the typical sections in the plans or as directed by the Engineer.

After the temporary pavement has served its purpose, remove the portions deemed unsuitable for use as a permanent part of the project as directed by the Engineer. Salvage and stockpile the aggregate base course removed from the temporary pavement locations within the right of way, as directed by the Engineer, for removal by State Forces. Place pavement and earth material removed from the temporary pavement locations in embankments or dispose of in waste areas furnished by the Contractor.

Pipe culverts removed from the temporary pavement locations remain the property of the Contractor. Pipe culverts that are removed will be measured and will be paid at the contract unit price per linear foot for *Pipe Removal*. Payment for the construction of the temporary pavement will be made at the contract unit prices for the various items involved.

No direct payment will be made for removing the aggregate base course, earth material and pavement, as the cost of same shall be included in the lump sum price bid for *Grading*. Such prices and payments will be full compensation for the work of removing, salvaging, and stockpiling aggregate base course; and for placing earth material and pavement in embankments or disposing of earth material and pavement in waste areas.

SHOULDER AND FILL SLOPE MATERIAL:

(5-21-02)

235, 560

SP2 R45 A

Description

Perform the required shoulder and slope construction for this project in accordance with the applicable requirements of Section 560 and Section 235 of the *2018 Standard Specifications*.

Measurement and Payment

Where the material has been obtained from an authorized stockpile or from a borrow source and *Borrow Excavation* is not included in the contract, no direct payment will be made for this work, as the cost of this work will be part of the work being paid at the contract lump sum price for *Grading*. If *Borrow Excavation* is included in this contract and the material has been obtained from an authorized stockpile or from a borrow source, measurement and payment will be as provided in Section 230 of the *2018 Standard Specifications* for *Borrow Excavation*.

MANUFACTURED QUARRY FINES IN EMBANKMENTS:

(01-17-17)(Rev. 7-18-23)

235

SP02 R72

Description

This specification addresses the use of manufactured quarry fines that are not classified as select materials. The specification allows the Contractor an option, with the approval of the Engineer, to use manufactured quarry fines (MQFs) in embankments as a substitute for conventional borrow material. Furnish and place geotextile for subgrade stabilization in accordance with the contract. Geotextile for subgrade stabilization is required to prevent pavement cracking and provide separation between the subgrade and pavement section at embankment locations where manufactured quarry fines are utilized and as directed by the Engineer.

Materials

Manufactured Quarry Fines.

Site specific approval of MQFs material will be required prior to beginning construction as detailed in the preconstruction requirements of this provision.

The following MQFs are unacceptable:

- (A) Frozen material,
- (B) Material with a maximum dry unit weight of less than 90 pounds per cubic foot when tested in accordance with AASHTO T-99 Method A or C.
- (C) Material with greater than 80% by weight Passing the #200 sieve

Collect and transport MQFs in a manner that will prevent nuisances and hazards to public health and safety. Moisture condition the MQFs as needed and transport in covered trucks to prevent dusting. If MQFs are blended with natural earth material, follow Borrow Criteria in Section 1018 of the *Standard Specifications*.

Geotextiles

Areas of embankment where MQFs are incorporated, Geotextile for Subgrade Stabilization shall be used. If the Geotextile for Subgrade Stabilization special provision is not included elsewhere in this contract, then it along with a detail will be incorporated as part of the contractors request to use.

Preconstruction Requirements

When MQFs are to be used as a substitute for earth borrow material, request written approval from the Engineer at least ninety (90) days in advance of the intent to use MQFs and include the following details:

- (A) Description, purpose and location of project.
- (B) Estimated start and completion dates of project.
- (C) Estimated volume of MQFs to be used on project with specific locations and construction details of the placement.
- (D) The names, address, and contact information for the generator of the MQFs.
- (E) Physical location of the site at which the MQFs were generated.

The Engineer will forward this information to the State Materials Engineer for review and material approval.

Construction Methods

Place MQFs in the core of the embankment section with at least 4 feet of earth cover to the outside limits of the embankments or subgrade.

Construct embankments by placing MQFs in level uniform lifts with no more than a lift of 10 inches and compacted to at least a density of 95 percent as determined by test methods in AASHTO T-99, Determination of Maximum Dry Density and Optimum Moisture Content, Method A or C depending upon particle size of the product. Provide a moisture content at the time of compaction of within 4 percent of optimum but not greater than one percent above optimum as determined by AASHTO T-99, Method A or C.

Areas of embankment where MQFs are incorporated, Geotextile for Subgrade Stabilization shall be used. See the contract for geotextile type and construction method for Geotextile for Subgrade Stabilization.

Measurement and Payment

Borrow Excavation will be measured by truck volume and paid in cubic yards in accordance with Article 230-5 of the *2018 Standard Specifications*. As an alternate weigh tickets can be provided and payment made by converting weight to cubic yards based on the verifiable unit weight.

When the pay item for *Geotextile for Subgrade Stabilization* is included in the original contract the material will be measured and paid in accordance with the contract. When the pay item for *Geotextile for Subgrade Stabilization* is not included in the original contract then no payment will be made for this item and will be considered incidental to the use of MQFs in embankment.

FLOWABLE FILL:

(9-17-02) (Rev 1-17-12)

300, 340, 1000, 1530, 1540, 1550

SP3 R30

Description

This work consists of all work necessary to place flowable fill in accordance with these provisions, the plans, and as directed.

Materials

Refer to Division 10 of the *2018 Standard Specifications*.

Item	Section
Flowable Fill	1000-6

Construction Methods

Discharge flowable fill material directly from the truck into the space to be filled, or by other approved methods. The mix may be placed full depth or in lifts as site conditions dictate. The Contractor shall provide a method to plug the ends of the existing pipe in order to contain the flowable fill.

Measurement and Payment

At locations where flowable fill is called for on the plans and a pay item for flowable fill is included in the contract, *Flowable Fill* will be measured in cubic yards and paid as the actual number of cubic yards that have been satisfactorily placed and accepted. Such price and payment will be full compensation for all work covered by this provision including, but not limited to, the mix design, furnishing, hauling, placing and containing the flowable fill.

Payment will be made under:

Pay Item	Pay Unit
Flowable Fill	Cubic Yard

CORRUGATED ALUMINUM ALLOY CULVERT PIPE:

(9-21-21)

305, 310

SP3 R34

Revise the *Standard Specifications* as follows:

Page 3-5, Article 305-2, MATERIALS, add the following after line 16:

Item	Section
Waterborne Paint	1080-9
Hot Bitumen	1081-3

Page 3-5, Article 305-3, CONSTRUCTION METHODS, add the following after line 24:

Coating must be applied to the aluminum when in contact with concrete. Immediately prior to coating, aluminum surfaces to be coated shall be cleaned by a method that will remove all dirt, oil,

grease, chips, and other foreign substances. Aluminum to be coated shall be given one coat of suitable quality coating such as:

Approved waterborne paint (Section 1080-9)

Approved Hot Bitumen (Section 1081-3)

Other coating materials may be submitted to the Engineer for approval.

Page 3-7, Article 310-6, MEASUREMENT AND PAYMENT, lines 6-11, delete the fourth sentence and replace with the following:

Select bedding and backfill material and coating will be included in the cost of the installed pipe. Such price and payment will be full compensation for all materials, labor, equipment, and other incidentals necessary to complete the work.

CULVERT PIPE:

(8-20-19)(Rev. 5-17-22)

305,310

SP3 R35

Revise the *2018 Standard Specifications* as follows:

Page 3-5, Article 305-1 DESCRIPTION, lines 12-14, replace with the following:

Where shown in the plans, the Contractor may use reinforced concrete pipe, aluminum alloy pipe, aluminized corrugated steel pipe, galvanized corrugated steel pipe, HDPE pipe, Polypropylene pipe or PVC pipe in accordance with the following requirements.

Page 3-5, Article 305-2 MATERIALS, add the following after line 16:

Item	Section
Polypropylene Pipe	1032-9
Galvanized Corrugated Steel Pipe	1032-3

Page 3-6, Article 310-2 MATERIALS, add the following after line 9:

Item	Section
Polypropylene Pipe	1032-9
Galvanized Corrugated Steel Pipe	1032-3

Page 3-6, Article 310-4 SIDE DRAIN PIPE, lines 24-25, replace the first sentence of the second paragraph with the following:

Where shown in the plans, side drain pipe may be Class II reinforced concrete pipe, aluminized corrugated steel pipe, galvanized corrugated steel pipe, corrugated aluminum alloy pipe, Polypropylene pipe, HDPE pipe or PVC pipe.

Page 3-7, Article 310-5 PIPE END SECTIONS, lines 2-4, replace the second sentence with the following:

Both corrugated steel and concrete pipe end sections will work on concrete pipe, corrugated steel

pipe, Polypropylene pipe and HDPE smooth lined corrugated plastic pipe.

Page 3-7, Article 310-6 MEASUREMENT AND PAYMENT, add the following after line 14:

Pay Item	Pay Unit
___" Polypropylene Pipe	Linear Foot

Page 10-60, add Article 1032-9:

(A) General

Use polypropylene pipe from sources participating in the Department's Polypropylene Pipe QA/QC Program. A list of participating sources is available from the Materials and Tests Unit. The Department will remove a manufacturer of polypropylene pipe from this program if the monitoring efforts indicated that non-specification material is being provided or test procedures are not being followed.

Use polypropylene culvert pipe that meets AASHTO M 330 for Type S or Type D, or ASTM F2881 or ASTM F2764 Double or Triple wall; and has been evaluated by NTPEP.

(B) End Treatments, Pipe Tees and Elbows

End treatments, pipe tees and elbows shall meet AASHTO M 330, Section 7.7, or ASTM F2764, Section 6.6.

(C) Marking

Clearly mark each section of pipe, end section, tee and elbow and other accessories according to the Department's Polypropylene Pipe QC/QA Program:

- (1) AASHTO or ASTM Designation
- (2) The date of manufacture
- (3) Name or trademark of the manufacturer

When polypropylene pipe, end sections, tees and elbows have been inspected and accepted a sticker will be applied to the inside of the pipe. Do not use pipe sections, flared end sections, tees or elbows which do not have this seal of approval.

INCIDENTAL MILLING:

(11-15-22)(Rev. 1-17-23)

607

SP6 R02R

Revise the *2018 Standard Specifications* as follows:

Page 6-5, Article 607-3 CONSTRUCTION METHODS, add the following paragraph after line 45:

Variable depth milling is intended to improve the cross-sectional slope of the pavement.

Page 6-6, Article 607-3 CONSTRUCTION METHODS, line 9, delete and replace the first

sentence in the sixth paragraph with the following:

The Engineer may require re-milling of any area exhibiting pavement laminations, scabbing or other defects.

Page 6-6, Article 607-4 TOLERANCE, lines 17-18, delete and replace the second sentence with the following:

The Engineer may vary the depth of milling by not more than one inch. In the event the directed depth of milling cut is altered by the Engineer more than one inch, either the Department or the Contractor may request an adjustment in unit price in accordance with Article 104-3. In administering Article 104-3, the Department will give no consideration to value given to RAP due to the deletion or reduction in quantity of milling. Article 104-3 will not apply to the item of *Incidental Milling*.

Page 6-6, Subarticle 607-5(A) Milled Asphalt Pavement, lines 21-23, delete and replace the first sentence with the following:

Milled Asphalt Pavement, __" Depth will be measured and paid as the actual number of square yards of pavement surface milled in accordance with this specification.

Page 6-6, Subarticle 607-5(A) Milled Asphalt Pavement, lines 24-28, delete and replace the third and fourth sentence with the following:

The width will be the width required by the plans or directed by the Engineer, measured along the pavement surface. Areas to be paid under this item include mainline travel lanes, full width turn lanes greater than 500 feet in length, collector lanes, shoulders, and any additional equipment necessary to remove pavement in the area of manholes, water valves, curb, gutter and other obstructions.

Page 6-6, Subarticle 607-5(B) Milled Asphalt Pavement Depth Varies from Required Depth, lines 29-37, delete and replace the title and first paragraph with the following:

(B) Variable Depth Milled Asphalt Pavement

Milling Asphalt Pavement, __" to __" will be measured and paid as the actual number of square yards of pavement surface milled in accordance with this specification. In measuring this quantity, the length will be the actual length milled, measured along the pavement surface. The width will be the width required by the plans or directed by the Engineer, measured along the pavement surface. Areas to be paid under this item include mainline travel lanes, full width turn lanes greater than 500 feet in length, collector lanes, shoulders, and any additional equipment necessary to remove pavement in the area of manholes, water valves, curb, gutter and other obstructions.

Page 6-6, Subarticle 607-5(C) Incidental Milling, lines 45-49, delete and replace the first and second sentence with the following:

Incidental Milling will be measured and paid as the actual number of square yards of surface milled where the Contractor is required to mill butt joints, irregular areas, full width turn lanes

500 feet or less, intersections and re-mill areas that are not due to the Contractor's negligence. In measuring this quantity, the length will be the actual length milled, measured along the pavement surface. The width will be the width required by the plans or directed by the Engineer, measured along the pavement surface.

Page 6-7, Subarticle 607-5(D) Milling of Defects, lines 6-10, delete and replace the second sentence with the following:

If the Engineer directs re-milling of an area and is not due to the Contractor's negligence, the re-milled area will be measured as provided in Subarticle 607-5(C) and paid at the contract unit price per square yard for *Incidental Milling*.

PRICE ADJUSTMENT - ASPHALT BINDER FOR PLANT MIX:

(11-21-00)

620

SP6 R25

Price adjustments for asphalt binder for plant mix will be made in accordance with Section 620 of the *2018 Standard Specifications*.

The base price index for asphalt binder for plant mix is **\$ 612.50** per ton.

This base price index represents an average of F.O.B. selling prices of asphalt binder at supplier's terminals on **October 1, 2023**.

FINAL SURFACE TESTING NOT REQUIRED:

(5-18-04) (Rev. 2-16-16)

610

SP6 R45

Final surface testing is not required on this project in accordance with Section 610-13, *Final Surface Testing and Acceptance*.

MILLING ASPHALT PAVEMENT:

(1-15-19)

607

SP6 R59

Revise the *2018 Standard Specifications* as follows:

Page 6-5, Article 607-2, EQUIPMENT, lines 14-16, delete the seventh sentence of this Article and replace with the following:

Use either a non-contacting laser or sonar type ski system with a minimum of three referencing stations mounted on the milling machine at a length of at least 24 feet.

7" JOINTED CONCRETE TRUCK APRON WITH WIRE MESH:

Description

Construct 7" Jointed Concrete Truck Apron in accordance with the plans and as directed by the Engineer.

Materials

Concrete shall be Class AA Concrete meeting the requirements of Section 1000 of the *Standard*

Specifications.

Wire mesh reinforcement shall be W3.5xW3.5 or W4xW4 welded wire fabric meeting the requirements of Section 1070 of the *2018 Standard Specifications*. The wire mesh reinforcement shall be centered in the 7" slab.

Construction Methods

Construct joints as directed by the Engineer.

Measurement and Payment

7" *Jointed Concrete Truck Apron With Wire Mesh* will be measured and paid for in square yards of truck apron that has been completed and accepted. Such price and payment will be full compensation for all work of constructing the jointed concrete truck apron, including but not limited to excavating and backfilling, furnishing and placing concrete and wire mesh., constructing joints, and sealing the concrete.

Pay Item

7" Jointed Concrete Truck Apron With Wire Mesh

Pay Unit

Square Yard

ASPHALT CONCRETE PLANT MIX PAVEMENTS:

(2-20-18) (Rev. 7-18-23)

610, 1012

SP6 R65

Revise the *2018 Standard Specifications* as follows:

Page 6-14, Table 609-3, LIMITS OF PRECISION FOR TEST RESULTS, replace with the following:

Mix Property	Limits of Precision
25.0 mm sieve (Base Mix)	± 10.0%
19.0 mm sieve (Base Mix)	± 10.0%
12.5 mm sieve (Intermediate & Type P-57)	± 6.0%
9.5 mm sieve (Surface Mix)	± 5.0%
4.75 mm sieve (Surface Mix)	± 5.0%
2.36 mm sieve (All Mixes, except S4.75A)	± 5.0%
1.18 mm sieve (S4.75A)	± 5.0%
0.075 mm sieve (All Mixes)	± 2.0%
Asphalt Binder Content	± 0.5%
Maximum Specific Gravity (G_{mm})	± 0.020
Bulk Specific Gravity (G_{mb})	± 0.030
TSR	± 15.0%
QA retest of prepared QC Gyratory Compacted Volumetric Specimens	± 0.015
Retest of QC Core Sample	± 1.2% (% Compaction)
Comparison QA Core Sample	± 2.0% (% Compaction)

QA Verification Core Sample	± 2.0% (% Compaction)
Density Gauge Comparison of QC Test	± 2.0% (% Compaction)
QA Density Gauge Verification Test	± 2.0% (% Compaction)

Page 6-17, Table 610-1, MIXING TEMPERATURE AT THE ASPHALT PLANT, replace with the following:

Binder Grade	JMF Temperature
PG 58-28; PG 64-22	250 - 290°F
PG 76-22	300 - 325°F

Page 6-17, Subarticle 610-3(C), Job Mix Formula (JMF), lines 38-39, delete the fourth paragraph.

Page 6-18, Subarticle 610-3(C), Job Mix Formula (JMF), line 12, replace “SF9.5A” with “S9.5B”.

Page 6-18, Table 610-3, MIX DESIGN CRITERIA, replace with the following:

Mix Type	Design ESALs millions ^A	Binder PG Grade	Compaction Levels		Max. Rut Depth (mm)	Volumetric Properties ^B			
			G _{mm} @			VMA % Min.	VTM %	VFA Min.-Max.	%G _{mm} @ N _{ini}
			N _{ini}	N _{des}					
S4.75A	< 1	64 - 22	6	50	11.5	16.0	4.0 - 6.0	65 - 80	≤ 91.5
S9.5B	0 - 3	64 - 22	6	50	9.5	16.0	3.0 - 5.0	70 - 80	≤ 91.5
S9.5C	3 - 30	64 - 22	7	65	6.5	15.5	3.0 - 5.0	65 - 78	≤ 90.5
S9.5D	> 30	76 - 22	8	100	4.5	15.5	3.0 - 5.0	65 - 78	≤ 90.0
I19.0C	ALL	64 - 22	7	65	-	13.5	3.0 - 5.0	65 - 78	≤ 90.5
B25.0C	ALL	64 - 22	7	65	-	12.5	3.0 - 5.0	65 - 78	≤ 90.5
Design Parameter						Design Criteria			
All Mix Types	Dust to Binder Ratio (P _{0.075} / P _{be})					0.6 - 1.4 ^C			
	Tensile Strength Ratio (TSR) ^D					85% Min. ^E			

A. Based on 20 year design traffic.

B. Volumetric Properties based on specimens compacted to N_{des} as modified by the Department.

C. Dust to Binder Ratio (P_{0.075} / P_{be}) for Type S4.75A is 1.0 - 2.0.

D. NCDOT-T-283 (No Freeze-Thaw cycle required).

E. TSR for Type S4.75A & B25.0C mixes is 80% minimum.

Page 6-19, Table 610-5, BINDER GRADE REQUIREMENTS (BASED ON RBR%), replace with the following:

Mix Type	%RBR ≤ 20%	21% ≤ %RBR ≤ 30%	%RBR > 30%
S4.75A, S9.5B, S9.5C, I19.0C, B25.0C	PG 64-22	PG 64-22 ^A	PG-58-28
S9.5D, OGFC	PG 76-22 ^B	n/a	n/a

A. If the mix contains any amount of RAS, the virgin binder shall be PG 58-28.

- B. Maximum Recycled Binder Replacement (%RBR) is 18% for mixes using PG 76-22 binder.

Page 6-20, Table 610-6, PLACEMENT TEMPERATURES FOR ASPHALT, replace with the following:

Asphalt Concrete Mix Type	Minimum Surface and Air Temperature
B25.0C	35°F
I19.0C	35°F
S4.75A, S9.5B, S9.5C	40°F ^A
S9.5D	50°F

- A. For the final layer of surface mixes containing recycled asphalt shingles (RAS), the minimum surface and air temperature shall be 50°F.

Page 6-21, Article 610-8, SPREADING AND FINISHING, lines 34-35, delete the second sentence and replace with the following:

Use an MTV for all surface mix regardless of binder grade on Interstates, US Routes, and NC Routes (primary routes) that have 4 or more lanes and are median divided.

Page 6-21, Article 610-8, SPREADING AND FINISHING, lines 36-38, delete the fourth sentence and replace with the following:

Use MTV for all ramps, loops, and Y-lines that have 4 or more lanes and are median divided, and all full width acceleration lanes, full width deceleration lanes, and full width turn lanes that are greater than 1000 feet in length.

Page 6-23, Table 610-7, DENSITY REQUIREMENTS, replace with the following:

Mix Type	Minimum % G _{mm} (Maximum Specific Gravity)
S4.75A	85.0 ^A
S9.5B	90.0
S9.5C, S9.5D, I19.0C, B25.0C	92.0

- A. Compaction to the above specified density shall be required when the S4.75A mix is applied at a rate of 100 lbs/sy or higher.

Page 6-24, Article 610-13, FINAL SURFACE TESTING, lines 35-36, delete the second sentence and replace with the following:

Final surface testing is not required on ramps, loops and turn lanes.

Page 6-26, Subarticle 610-13(A)(1), Acceptance for New Construction, lines 29-30, delete the second sentence and replace with the following:

Areas excluded from testing by the profiler may be tested using a 10-foot straightedge in accordance with Article 610-12.

Page 6-27, Subarticle 610-13(B), Option 2- North Carolina Hearne Straightedge, lines 41-46, delete the eighth and ninth sentence of this paragraph and replace with the following:

Take profiles over the entire length of the final surface travel lane pavement exclusive of structures, approach slabs, paved shoulders, tapers, or other irregular shaped areas of pavement, unless otherwise approved by the Engineer. Test in accordance with this provision all mainline travel lanes, full width acceleration or deceleration lanes and collector lanes.

Page 6-28, Subarticle 610-13(B), Option 2- North Carolina Hearne Straightedge, lines 1-2, delete these two lines.

Page 6-32, Article 610-16 MEASUREMENT AND PAYMENT, replace with the following:

Pay Item	Pay Unit
Asphalt Concrete Base Course, Type B25.0C	Ton
Asphalt Concrete Intermediate Course, Type I19.0C	Ton
Asphalt Concrete Surface Course, Type S4.75A	Ton
Asphalt Concrete Surface Course, Type S9.5B	Ton
Asphalt Concrete Surface Course, Type S9.5C	Ton
Asphalt Concrete Surface Course, Type S9.5D	Ton

Page 10-30, Table 1012-1, AGGREGATE CONSENSUS PROPERTIES, replace with the following:

**TABLE 1012-1
AGGREGATE CONSENSUS PROPERTIES^A**

Mix Type	Coarse Aggregate Angularity^B	Fine Aggregate Angularity % Minimum	Sand Equivalent % Minimum	Flat and Elongated 5 : 1 Ratio % Maximum
<i>Test Method</i>	<i>ASTM D5821</i>	<i>AASHTO T 304</i>	<i>AASHTO T 176</i>	<i>ASTM D4791</i>
S4.75A; S9.5B	75 / -	40	40	-
S9.5C; I19.0C; B25.0C	95 / 90	45	45	10
S9.5D	100 / 100	45	50	10
OGFC	100 / 100	45	45	10
UBWC	100 / 85	45	45	10

A. Requirements apply to the design aggregate blend.

B. 95 / 90 denotes that 95% of the coarse aggregate has one fractured face and 90% has 2 or more fractured faces.

Page 10-30, Subarticle 1012-1(B)(6), Toughness (Resistance to Abrasion), line 12, replace “OGAFC” with “OGFC”.

SUPPLEMENTAL SURVEYING:

(4-20-21)

801

SP8 R03

Revise the *2018 Standard Specifications* as follows:

Page 8-7, Article 801-3 MEASUREMENT AND PAYMENT, lines 10-11, replace with the following:

Supplemental Surveying Office Calculations will be paid at the stated price of \$85.00 per hour. *Supplemental Field Surveying* will be paid at the stated price of \$145.00 per hour. The

GUARDRAIL END UNITS & TEMPORARY GUARDRAIL END UNITS, TYPE - TL-2:

(10-21-08) (Rev. 5-16-23)

862

SP8 R64

Description

Furnish and install guardrail end units in accordance with the details in the plans, the applicable requirements of Section 862 of the *Standard Specifications*, and at locations shown in the plans.

Materials

Furnish guardrail end units listed on the NCDOT APL. Units shall not be modified by the manufacturer and installer once approved and on the NCDOT APL.

Prior to installation the Contractor shall submit to the Engineer certified working drawings and assembling instructions from the manufacturer for each guardrail end unit in accordance with Article 105-2 of the *Standard Specifications*.

Perform installation in accordance with the details in the plans, and details and assembling instructions furnished by the manufacturer.

Construction Methods

Guardrail end delineation is required on all approach and trailing end sections for both temporary and permanent installations. Guardrail end delineation consists of yellow reflective sheeting applied to the entire end section of the guardrail in accordance with Article 1088-3 of the *Standard Specifications* and is incidental to the cost of the guardrail end unit.

Measurement and Payment

Measurement and payment will be made in accordance with Article 862-6 of the *Standard Specifications*.

Payment will be made under:

Pay Item

Guardrail End Units, Type TL-2
Temporary Guardrail End Units, Type TL-2

Pay Unit

Each
Each

GUARDRAIL END UNITS & TEMPORARY GUARDRAIL END UNITS, TYPE - TL-3:

(4-20-04) (Rev. 5-16-23)

862

SP8 R65

Description

Furnish and install guardrail end units in accordance with the details in the plans, the applicable requirements of Section 862 of the *Standard Specifications*, and at locations shown in the plans.

Materials

Furnish guardrail end units listed on the NCDOT APL. Units shall not be modified by the manufacturer and installer once approved and on the NCDOT APL.

Prior to installation the Contractor shall submit to the Engineer certified working drawings and assembling instructions from the manufacturer for each guardrail end unit in accordance with Article 105-2 of the *Standard Specifications*.

Perform installation in accordance with the details in the plans, and details and assembling instructions furnished by the manufacturer.

Construction Methods

Guardrail end delineation is required on all approach and trailing end sections for both temporary and permanent installations. Guardrail end delineation consists of yellow reflective sheeting applied to the entire end section of the guardrail in accordance with Article 1088-3 of the *Standard Specifications* and is incidental to the cost of the guardrail end unit.

Measurement and Payment

Measurement and payment will be made in accordance with Article 862-6 of the *Standard Specifications*.

Payment will be made under:

Pay Item	Pay Unit
Guardrail End Units, Type TL-3	Each
Temporary Guardrail End Units, Type TL-3	Each

GUARDRAIL ANCHOR UNITS AND TEMPORARY GUARDRAIL ANCHOR UNITS:

(1-16-2018)

862

SP8 R70

Guardrail anchor units will be in accordance with the details in the plans and the applicable requirements of Section 862 of the *2018 Standard Specifications*.

Revise the *2018 Standard Specifications* as follows:

Page 8-42, Article 862-6 MEASUREMENT AND PAYMENT, add the following:

Guardrail Anchor Units, Type ___ and Temporary Guardrail Anchor Units Type ___ will be measured and paid as units of each completed and accepted. No separate measurement will be

made of any rail, terminal sections, posts, offset blocks, concrete, hardware or any other components of the completed unit that are within the pay limits shown in the plans for the unit as all such components will be considered to be part of the unit.

Payment will be made under:

Pay Item	Pay Unit
Guardrail Anchor Units, Type ____	Each
Temporary Guardrail Anchor Units, Type ____	Each

HANDRAIL (ORNAMENTAL METAL FENCE):

Install handrail to match State Project Number U-5104 closest to the intersection of South Caldwell Street and West Jordan Street in Brevard, NC as directed by the engineer.

Payment will be made under:

Pay Item	Pay Unit
Handrail	Linear Foot

ADJUSTMENT OF CATCH BASINS, MANHOLES, DROP INLETS, METER BOXES AND VALVE BOXES:

(11-15-22)

858

SP8 R98R

Revise the *2018 Standard Specifications* as follows:

Page 8-38, Article 858-4 MEASUREMENT AND PAYMENT, lines 10-11, delete and replace the fifth paragraph with the following:

Where any catch basin, drop inlet, manhole, meter box or valve box is adjusted more than once because of milling operations, each adjustment will be measured and paid.

END OF MEDIAN MARKER:

(01-04-18)

Description

Furnish and install end of median markers with all associated material and labor necessary for the installation of each marker in accordance with the manufacturer's requirements and the details in the plans, at locations shown in the plans. End of median markers shall be used on the approach ends of medians to increase visibility.

Materials

The end of median markers shall consist of a high target value channelizer with mounting plate and mounting hardware. The end of median markers shall be installed on a hard structural surface such as concrete or asphalt.

Furnish end of median markers listed on the Approved Products List at <https://apps.dot.state.nc.us/vendor/approvedproducts/> or approved equal.

- (A) High Target Value Channelizers:** High target value channelizers shall be affixed to a detachable flexible rubber boot that supports the channelizer in a vertical position, and is capable of restoring the channelizer to the vertical position if struck by a vehicle. The channelizers shall be composed of high impact plastic and accommodate Type IV Prismatic High-Intensity retro-reflective sheeting.

Elliptical channelizers shall be used when traffic is moving generally parallel to the traffic separator. Elliptical channelizers shall have a mounting height of 40 to 44 inches above the roadway and be between 8 to 10 inches wide. Elliptical channelizers shall accommodate Type IV retro-reflective sheeting between 28 and 30 inches in height and between 7 ¾ and 8 inches in width providing a reflective area of 220 to 240 square inches facing the traffic.

Side one of the panel shall have Type IV yellow reflective sheeting material and shall include a scaled down version of the R1-2 Yield sign. Minimum overall size of the R1-2 sign shall be 12" by 12".

Install the R1-2 decal ½" below the top of the recess for the panel on side one.

- (B) Mounting Plate:** The channelizer mounting plate shall consist of a plastic plate capable of being installed onto a hard surface such a concrete or asphalt without being dislodged if impacted by a vehicle.

The plate should generally be square with no dimension exceeding 12". Each individual plate unit will have a receptacle for the installation of a channelizer with a flexible rubber boot. The plate shall be designed such that once the channelizer is installed in the plate, it is held firmly in place so that when a vehicle impacts the channelizer, it will rebound to its upright position. Base plates shall be yellow in color.

Construction Methods

- (A) High Target Value Channelizers:** Install per manufacturer's instructions.

- (B) Mounting Plate:** Anchor mounting plate in accordance with manufacturer's recommendations and with anchoring system supplied by the manufacturer. In some cases, the median may be grass, in which case a concrete pad will need to be installed to install the Bullnose marker on. If the median or traffic separator is asphalt or concrete, the mounting plate should be installed on top of the existing surface.

Measurement and Payment

End of Median Marker will be measured and paid at the contract unit price per each. Such prices and payment will be full compensation for all work covered by this provision including, but not limited to, furnishing, installing and all incidentals necessary to complete the work.

Payment will be made under:

Pay Item

End of Median Marker

Pay Unit

Each

FOUNDATIONS AND ANCHOR ROD ASSEMBLIES FOR METAL POLES:

(1-17-12) (Rev. 1-16-18)

9, 14, 17

SP9 R05

Description

Foundations for metal poles include foundations for signals, cameras, overhead and dynamic message signs (DMS) and high mount and light standards supported by metal poles or upright trusses. Foundations consist of footings with pedestals and drilled piers with or without grade beams or wings. Anchor rod assemblies consist of anchor rods (also called anchor bolts) with nuts and washers on the exposed ends of rods and nuts and a plate or washers on the other ends of rods embedded in the foundation.

Construct concrete foundations with the required resistances and dimensions and install anchor rod assemblies in accordance with the contract and accepted submittals. Construct drilled piers consisting of cast-in-place reinforced concrete cylindrical sections in excavated holes. Provide temporary casings or polymer slurry as needed to stabilize drilled pier excavations. Use a prequalified Drilled Pier Contractor to construct drilled piers for metal poles. Define "excavation" and "hole" as a drilled pier excavation and "pier" as a drilled pier.

This provision does not apply to foundations for signal pedestals; see Section 1743 of the *2018 Standard Specifications* and 2018 Roadway Standard Drawing No. 1743.01.

Materials

Refer to the *2018 Standard Specifications*.

Item	Section
Conduit	1091-3
Grout, Type 2	1003
Polymer Slurry	411-2(B)(2)
Portland Cement Concrete	1000
Reinforcing Steel	1070
Rollers and Chairs	411-2(C)
Temporary Casings	411-2(A)

Provide Type 3 material certifications in accordance with Article 106-3 of the *2018 Standard Specifications* for conduit, rollers, chairs and anchor rod assemblies. Store steel materials on blocking at least 12" above the ground and protect it at all times from damage; and when placing in the work make sure it is free from dirt, dust, loose mill scale, loose rust, paint, oil or other foreign materials. Load, transport, unload and store foundation and anchor rod assembly materials so materials are kept clean and free of damage. Bent, damaged or defective materials will be rejected.

Use conduit type in accordance with the contract. Use Class A concrete for footings and pedestals, Class Drilled Pier concrete for drilled piers and Class AA concrete for grade beams and wings

including portions of drilled piers above bottom of wings elevations. Corrugated temporary casings may be accepted at the discretion of the Engineer. A list of approved polymer slurry products is available from:

connect.ncdot.gov/resources/Geological/Pages/Products.aspx

Provide anchor rod assemblies in accordance with the contract consisting of the following:

- (A) Straight anchor rods,
- (B) Heavy hex top and leveling nuts and flat washers on exposed ends of rods, and
- (C) Nuts and either flat plates or washers on the other ends of anchor rods embedded in foundations.

Do not use lock washers. Use steel anchor rods, nuts and washers that meet ASTM F1554 for Grade 55 rods and Grade A nuts. Use steel plates and washers embedded in concrete with a thickness of at least 1/4". Galvanize anchor rods and exposed nuts and washers in accordance with Article 1076-4 of the *2018 Standard Specifications*. It is not necessary to galvanize nuts, plates and washers embedded in concrete.

Construction Methods

Install the required size and number of conduits in foundations in accordance with the plans and accepted submittals. Construct top of piers, footings, pedestals, grade beams and wings flat, level and within 1" of elevations shown in the plans or approved by the Engineer. Provide an Ordinary Surface finish in accordance with Subarticle 825-6(B) of the *2018 Standard Specifications* for portions of foundations exposed above finished grade. Do not remove anchor bolt templates or pedestal or grade beam forms or erect metal poles or upright trusses onto foundations until concrete attains a compressive strength of at least 3,000 psi.

(A) Drilled Piers

Before starting drilled pier construction, hold a predrill meeting to discuss the installation, monitoring and inspection of the drilled piers. Schedule this meeting after the Drilled Pier Contractor has mobilized to the site. The Resident or Division Traffic Engineer, Contractor and Drilled Pier Contractor Superintendent will attend this predrill meeting.

Do not excavate holes, install piles or allow equipment wheel loads or vibrations within 20 ft of completed piers until 16 hours after Drilled Pier concrete reaches initial set.

Check for correct drilled pier alignment and location before beginning drilling. Check plumbness of holes frequently during drilling.

Construct drilled piers with the minimum required diameters shown in the plans. Install piers with tip elevations no higher than shown in the plans or approved by the Engineer.

Excavate holes with equipment of the sizes required to construct drilled piers. Depending on the subsurface conditions encountered, drilling through rock and boulders may be required. Do not use blasting for drilled pier excavations.

Contain and dispose of drilling spoils and waste concrete as directed and in accordance with Section 802 of the *2018 Standard Specifications*. Drilling spoils consist of all materials and fluids removed from excavations.

If unstable, caving or sloughing materials are anticipated or encountered, stabilize holes with temporary casings and/or polymer slurry. Do not use telescoping temporary casings. If it becomes necessary to replace a temporary casing during drilling, backfill the excavation, insert a larger casing around the casing to be replaced or stabilize the excavation with polymer slurry before removing the temporary casing.

If temporary casings become stuck or the Contractor proposes leaving casings in place, temporary casings should be installed against undisturbed material. Unless otherwise approved, do not leave temporary casings in place for mast arm poles and cantilever signs. The Engineer will determine if casings may remain in place. If the Contractor proposes leaving temporary casings in place, do not begin drilling until a casing installation method is approved.

Use polymer slurry and additives to stabilize holes in accordance with the slurry manufacturer's recommendations. Provide mixing water and equipment suitable for polymer slurry. Maintain the required slurry properties at all times except for sand content.

Define a "sample set" as slurry samples collected from mid-height and within 2 ft of the bottom of holes. Take sample sets from excavations to test polymer slurry immediately after filling holes with slurry, at least every 4 hours thereafter and immediately before placing concrete. Do not place Drilled Pier concrete until both slurry samples from an excavation meet the required polymer slurry properties. If any slurry test results do not meet the requirements, the Engineer may suspend drilling until both samples from a sample set meet the required polymer slurry properties.

Remove soft and loose material from bottom of holes using augers to the satisfaction of the Engineer. Assemble rebar cages and place cages and Drilled Pier concrete in accordance with Subarticle 411-4(E) of the *2018 Standard Specifications* except for the following:

- (1) Inspections for tip resistance and bottom cleanliness are not required,
- (2) Temporary casings may remain in place if approved, and
- (3) Concrete placement may be paused near the top of pier elevations for anchor rod assembly installation and conduit placement or
- (4) If applicable, concrete placement may be stopped at bottom of grade beam or wings elevations for grade beam or wing construction.

If wet placement of concrete is anticipated or encountered, do not place Drilled Pier concrete until a concrete placement procedure is approved. If applicable, temporary casings and fluids may be removed when concrete placement is paused or stopped in

accordance with the exceptions above provided holes are stable. Remove contaminated concrete from exposed Drilled Pier concrete after removing casings and fluids. If holes are unstable, do not remove temporary casings until a procedure for placing anchor rod assemblies and conduit or constructing grade beams or wings is approved.

Use collars to extend drilled piers above finished grade. Remove collars after Drilled Pier concrete sets and round top edges of piers.

If drilled piers are questionable, pile integrity testing (PIT) and further investigation may be required in accordance with Article 411-5 of the *2018 Standard Specifications*. A drilled pier will be considered defective in accordance with Subarticle 411-5(D) of the *2018 Standard Specifications* and drilled pier acceptance is based in part on the criteria in Article 411-6 of the *2018 Standard Specifications* except for the top of pier tolerances in Subarticle 411-6(C) of the *2018 Standard Specifications*.

If a drilled pier is under further investigation, do not grout core holes, backfill around the pier or perform any work on the drilled pier until the Engineer accepts the pier. If the drilled pier is accepted, dewater and grout core holes and backfill around the pier with approved material to finished grade. If the Engineer determines a pier is unacceptable, remediation is required in accordance with Article 411-6 of the *2018 Standard Specifications*. No extension of completion date or time will be allowed for remediation of unacceptable drilled piers or post repair testing.

Permanently embed a plate in or mark top of piers with the pier diameter and depth, size and number of vertical reinforcing bars and the minimum compressive strength of the concrete mix at 28 days.

(B) Footings, Pedestals, Grade Beams and Wings

Excavate as necessary for footings, grade beams and wings in accordance with the plans, accepted submittals and Section 410 of the *2018 Standard Specifications*. If unstable, caving or sloughing materials are anticipated or encountered, shore foundation excavations as needed with an approved method. Notify the Engineer when foundation excavation is complete. Do not place concrete or reinforcing steel until excavation dimensions and foundation material are approved.

Construct cast-in-place reinforced concrete footings, pedestals, grade beams and wings with the dimensions shown in the plans and in accordance with Section 825 of the *2018 Standard Specifications*. Use forms to construct portions of pedestals and grade beams protruding above finished grade. Provide a chamfer with a 3/4" horizontal width for pedestal and grade beam edges exposed above finished grade. Place concrete against undisturbed soil or backfill and fill in accordance with Article 410-8 of the *2018 Standard Specifications*. Proper compaction around footings and wings is critical for foundations to resist uplift and torsion forces.

(C) Anchor Rod Assemblies

Size anchor rods for design and the required projection above top of foundations. Determine required anchor rod projections from nut, washer and base plate thicknesses, the protrusion of 3 to 5 anchor rod threads above top nuts after tightening and the distance of one nut thickness between top of foundations and bottom of leveling nuts.

Protect anchor rod threads from damage during storage and installation of anchor rod assemblies. Before placing anchor rods in foundations, turn nuts onto and off rods past leveling nut locations. Turn nuts with the effort of one workman using an ordinary wrench without a cheater bar. Report any thread damage to the Engineer that requires extra effort to turn nuts.

Arrange anchor rods symmetrically about center of base plate locations as shown in the plans. Set anchor rod elevations based on required projections above top of foundations. Securely brace and hold rods in the correct position, orientation and alignment with a steel template. Do not weld to reinforcing steel, temporary casings or anchor rods.

Install top and leveling (bottom) nuts, washers and the base plate for each anchor rod assembly in accordance with the following procedure:

- (1) Turn leveling nuts onto anchor rods to a distance of one nut thickness between the top of foundation and bottom of leveling nuts. Place washers over anchor rods on top of leveling nuts.
- (2) Determine if nuts are level using a flat rigid template on top of washers. If necessary, lower leveling nuts to level the template in all directions or if applicable, lower nuts to tilt the template so the metal pole or upright truss will lean as shown in the plans. If leveling nuts and washers are not in full contact with the template, replace washers with galvanized beveled washers.
- (3) Verify the distance between the foundation and leveling nuts is no more than one nut thickness.
- (4) Place base plate with metal pole or upright truss over anchor rods on top of washers. High mount luminaires may be attached before erecting metal poles but do not attach cables, mast arms or trusses to metal poles or upright trusses at this time.
- (5) Place washers over anchor rods on top of base plate. Lubricate top nut bearing surfaces and exposed anchor rod threads above washers with beeswax, paraffin or other approved lubricant.
- (6) Turn top nuts onto anchor rods. If nuts are not in full contact with washers or washers are not in full contact with the base plate, replace washers with galvanized beveled washers.
- (7) Tighten top nuts to snug-tight with the full effort of one workman using a 12" wrench. Do not tighten any nut all at once. Turn top nuts in increments. Follow a star pattern cycling through each nut at least twice.
- (8) Repeat (7) for leveling nuts.
- (9) Replace washers above and below the base plate with galvanized beveled washers if the slope of any base plate face exceeds 1:20 (5%), any washer is not in firm contact with the base plate or any nut is not in firm contact with a washer. If any washers are replaced, repeat (7) and (8).

- (10) With top and leveling nuts snug-tight, mark each top nut on a corner at the intersection of 2 flats and a corresponding reference mark on the base plate. Mark top nuts and base plate with ink or paint that is not water-soluble. Use the turn-of-nut method for pretensioning. Do not pretension any nut all at once. Turn top nuts in increments for a total turn that meets the following nut rotation requirements:

NUT ROTATION REQUIREMENTS (Turn-of-Nut Pretensioning Method)	
Anchor Rod Diameter, inch	Requirement
$\leq 1 \frac{1}{2}$	1/3 turn (2 flats)
$> 1 \frac{1}{2}$	1/6 turn (1 flat)

Follow a star pattern cycling through each top nut at least twice.

- (11) Ensure nuts, washers and base plate are in firm contact with each other for each anchor rod. Cables, mast arms and trusses may now be attached to metal poles and upright trusses.
- (12) Between 4 and 14 days after pretensioning top nuts, use a torque wrench calibrated within the last 12 months to check nuts in the presence of the Engineer. Completely erect mast arm poles and cantilever signs and attach any hardware before checking top nuts for these structures. Check that top nuts meet the following torque requirements:

TORQUE REQUIREMENTS	
Anchor Rod Diameter, inch	Requirement, ft-lb
7/8	180
1	270
1 1/8	380
1 1/4	420
$\geq 1 \frac{1}{2}$	600

If necessary, retighten top nuts in the presence of the Engineer with a calibrated torque wrench to within ± 10 ft-lb of the required torque. Do not overtighten top nuts.

- (13) Do not grout under base plate.

Measurement and Payment

Foundations and anchor rod assemblies for metal poles and upright trusses will be measured and paid for elsewhere in the contract.

No payment will be made for temporary casings that remain in drilled pier excavations. No payment will be made for PIT. No payment will be made for further investigation of defective piers. Further investigation of piers that are not defective will be paid as extra work in accordance with Article 104-7 of the *2018 Standard Specifications*. No payment will be made for remediation of unacceptable drilled piers or post repair testing.

PORTLAND CEMENT CONCRETE PRODUCTION AND DELIVERY:

(9-15-20)

1000, 1014, 1024

SP10 R01

Revise the *2018 Standard Specifications* as follows:

Page 10-6, Table 1000-1, REQUIREMENTS FOR CONCRETE, replace with the following:

TABLE 1000-1 REQUIREMENTS FOR CONCRETE											
Class of Concrete	Min. Compressive Strength at 28 days	Maximum Water-Cement Ratio				Consistency Maximum Slump		Cement Content			
		Air-Entrained Concrete		Non-Air- Entrained Concrete		Vibrated	Non- Vibrated	Vibrated		Non-Vibrated	
		Rounded Aggregate	Angular Aggregate	Rounded Aggregate	Angular Aggregate			Min.	Max.	Min.	Max.
		Units	psi					inch	inch	lb/cy	lb/cy
AA	4500	0.381	0.426	---	---	3.5 ^A	---	639	715	---	---
AA Slip Form	4500	0.381	0.426	---	---	1.5	---	639	715	---	---
Drilled Pier	4500	---	---	0.450	0.450	---	5 - 7 dry 7 - 9 wet	---	---	640	800
A	3000	0.488	0.532	0.550	0.594	3.5 ^A	4.0	564	---	602	---
B	2500	0.488	0.567	0.559	0.630	1.5 machine placed 2.5 ^A hand placed	4.0	508	---	545	---
Sand Light- weight	4500	---	0.420	---	---	4.0 ^A	---	715	---	---	---
Latex Modified	3000 (at 7 days)	0.400	0.400	---	---	6.0	---	658	---	---	---
Flowable Fill excavatable	150 max. (at 56 days)	as needed	as needed	as needed	as needed	---	Flowable	---	---	40	100
Flowable Fill non- excavatable	125	as needed	as needed	as needed	as needed	---	Flowable	---	---	100	as needed
Pavement	4500 Design, field 650 flexural, design only	0.559	0.559	---	---	1.5 slip form 3.0 hand placed	---	526	---	---	---
Precast	See Table 1077-1	as needed	as needed	---	---	6.0	as needed	as needed	as needed	as needed	as needed
Prestressed	per contract	See Table 1078-1	See Table 1078-1	---	---	8.0	---	564	as needed	---	---

- A. The slump may be increased to 6 inches, provided the increase in slump is achieved by adding a chemical admixture conforming to Section 1024-3. In no case shall the water-cement ratio on the approved design be exceeded. Concrete exhibiting segregation and/or excessive bleeding will be rejected. Utilizing an Admixture to modify slump does not relinquish the contractor's responsibility to ensure the final product quality and overall configuration meets design specifications. Caution should be taken when placing these modified mixes on steep grades to prevent unintended changes to the set slope.

THERMOPLASTIC INTERMIXED BEAD TESTING:

7-19-22

1087

SP10 R04

Revise the *2018 Standard Specifications* as follows:

Page 10-183, Subarticle 1087-7(B) Thermoplastic Pavement Marking Material Composition, delete line 34 and 35.

Page 10-184, Article 1087-8 MATERIAL CERTIFICATION, delete and replace with the following after line 34:

Drop-on Glass Beads	Type 3 Material Certification and Type 4 Material Certification
Intermix Glass Beads	Type 2 Material Certification and Type 3 Material Certification
Paint	Type 3 Material Certification
Removable Tape	Type 3 Material Certification
Thermoplastic	Type 3 Material Certification and Type 4 Material Certification
Cold Applied Plastic	Type 2 Material Certification and Type 3 Material Certification
Polyurea	Type 2 Material Certification and Type 3 Material Certification

THERMOPLASTIC PAVEMENT MARKING MATERIAL – COLOR TESTING:

3-19-19

1087

SP10 R05

Revise the *2018 Standard Specifications* as follows:

Pages 10-183 and 10-184, Subarticle 1087-7(D)(1)(b) Yellow, lines 9-11, delete and replace with the following:

Obtain Color Values Y,x,y per ASTM E1349 using C/2° illuminant/observer.
Results shall be $Y \geq 45\%$, and x,y shall fall within PR#1 chart chromaticity limits.

NON-CAST IRON SNOWPLOWABLE PAVEMENT MARKERS:

10-19-21 (Rev. 11-16-21)

1086, 1250, 1253

SP10 R08

Revise the *2018 Standard Specifications* as follows:

Pages 10-177 and 10-178, Subarticle 1086-3 SNOWPLOWABLE PAVEMENT MARKERS, delete items (A), (B) and (C)(1) and replace with the following:

(A) General

Use non-cast iron snowplowable pavement markers evaluated by NTPEP. The non-cast iron snowplowable pavement marker shall consist of a housing with one or more glass or plastic face lens type reflective lenses to provide the required color designation. The marker shall be designed or installed in a manner that minimizes damage from snowplow blades. Plastic lens faces shall use an abrasion resistant coating.

(B) Housings**(1) Dimensions**

The dimension, slope and minimum area of reflecting surface shall conform to dimensions as shown in the plans. The minimum area of each reflecting surface shall be 1.44 sq.in.

(2) Materials

Use non-cast iron snowplowable pavement markers that are on the NCDOT Approved Products List.

(3) Surface

The surface of the housing shall be free of scale, dirt, rust, oil, grease or any other contaminant which might reduce its bond to the epoxy adhesive.

(4) Identification

Mark the housing with the manufacturer's name and model number of marker.

(C) Reflectors**(1) General**

Laminate the reflector to an elastomeric pad and attach with adhesive to the housing. The thickness of the elastomeric pad shall be 0.04".

Pages 12-14, Subarticle 1250-3(C) Removal of Existing Pavement Markers, lines 19-29, delete and replace with the following:

Remove the existing raised pavement markers or the snowplowable pavement markers including the housings, before overlaying an existing roadway with pavement. Repair the pavement by filling holes as directed by the Engineer.

When traffic patterns are changed in work zones due to construction or reconstruction, remove all raised pavement markers or snowplowable markers including housings that conflict with the new traffic pattern before switching traffic to the new traffic pattern. Lens removal in lieu of total housing removal is not an acceptable practice for snowplowable markers.

Properly dispose of the removed pavement markers. No direct payment will be made for removal or disposal of existing pavement markers or repair of pavement, as such work will be incidental to other items in the contract.

Pages 12-16, Subarticle 1253-1 DESCRIPTION, lines 4-5, delete and replace with the following:

Furnish, install and maintain non-cast iron snowplowable pavement markers in accordance with the contract.

Pages 12-16 and 12-17, Subarticle 1253-3 CONSTRUCTION METHODS, delete items (A), (B) and (C) and replace with the following:

(A) General

Bond marker housings to the pavement with epoxy adhesive. Mechanically mix and dispense epoxy adhesives as required by the manufacturer's specifications. Place the markers immediately after the adhesive has been mixed and dispensed.

If saw cutting, milling, or grooving operations are used, promptly remove all resulting debris from the pavement surface. Install the marker housings within 7 calendar days after saw cutting, milling, or grooving the pavement. Remove and dispose of loose material from the slots by brushing, blow cleaning, or vacuuming. Dry the slots before applying the epoxy adhesive. Install non-cast iron snowplowable pavement markers according to the manufacturer's recommendations.

Protect the non-cast iron snowplowable pavement markers until the epoxy has initially cured and is track free.

(B) Reflector Replacement

In the event that a reflector is damaged, replace the damaged reflector by using adhesives and methods recommended by the manufacturer of the markers and approved by the Engineer. This work is considered incidental if damage occurs during the initial installation of the marker housings and maintenance of initial non-cast iron snowplowable markers specified in this section. This work will be paid for under the pay item for the type of reflector replacement if the damage occurred after the initial installation of the non-cast iron snowplowable pavement marker.

Missing housings shall be replaced. Broken housings shall be removed and replaced. In both cases the slot for the housings shall be properly prepared prior to installing the new housing; patch the existing marker slots as directed by the Engineer and install the new marker approximately one foot before or after the patch. Removal of broken housings and preparation of slots will be considered incidental to the work of replacing housings.

Pages 12-17, Subarticle 1253-4 MAINTENANCE, lines 5, delete and replace with the following:

Maintain all installed non-cast iron snowplowable pavement markers until acceptance.

Pages 12-17, Subarticle 1253-5 MEASUREMENT AND PAYMENT, lines 7-8, delete and replace with the following:

Non-Cast Iron Snowplowable Pavement Markers will be measured and paid as the actual number of non-cast iron snowplowable pavement markers satisfactorily placed and accepted by the Engineer.

Pages 12-17, Subarticle 1253-5 MEASUREMENT AND PAYMENT, lines 11, delete and replace with the following:

Payment will be made under:

Pay Item

Non-Cast Iron Snowplowable Pavement Marker
 Replace Snowplowable Pavement Marker Reflector

Pay Unit

Each
 Each

MATERIALS FOR PORTLAND CEMENT CONCRETE:

(9-15-20)

1000, 1024

SP10 R24

Revise the *2018 Standard Specifications* as follows:

Page 10-52, Article 1024-4, WATER, lines 3-6, delete and replace with the following:

Test water from wells at all locations. Test public water supplies from all out of state locations and in the following counties: Beaufort, Bertie, Brunswick, Camden, Carteret, Chowan, Craven, Currituck, Dare, Gates, Hyde, New Hanover, Onslow, Pamlico, Pasquotank, Pender, Perquimans, Tyrell and Washington unless the Engineer waives the testing requirements.

Page 10-52, Table 1024-2, PHYSICAL PROPERTIES OF WATER, replace with the following:

Property	Requirement	Test Method
Compression Strength, minimum percent of control at 3 and 7 days	90%	ASTM C1602
Time of set, deviation from control	From 1:00 hr. earlier to 1:30 hr. later	ASTM C1602
pH	4.5 to 8.5	ASTM D1293 *
Chloride Ion Content, Max.	250 ppm	ASTM D512 *
Total Solids Content (Residue), Max.	1,000 ppm	SM 2540B *
Resistivity, Min.	0.500 kohm-cm	ASTM D1125 *

*Denotes an alternate method is acceptable. Test method used shall be referenced in the test report.

GEOSYNTHETICS:

(03-21-23)(Rev. 4-18-23)

1056

SP10 R56

Revise the *Standard Specifications* as follows:

Page 10-77, Article 1056-1 DESCRIPTION, lines 13-16, delete and replace the second sentence in the second paragraph with the following:

Steel anchor pins shall have a diameter of at least 3/16 inch, a length of at least 18 inches, a point at one end and a head at the other end that will retain a steel washer with an outside diameter of at least 1.5 inches.

Page 10-77, Article 1056-2 HANDLING AND STORING, lines 20-21, delete and replace the third sentence in the first paragraph with the following:

Geosynthetics with defects, flaws, deterioration or damage will be rejected by the Engineer.

Page 10-77, Article 1056-3 CERTIFICATIONS AND IDENTIFICATION, lines 25-27, delete and replace the first sentence in the first paragraph with the following:

Provide Type 1, Type 2 or Type 4 material certifications in accordance with Article 106-3 for geosynthetics except certifications are not required for Type 1 through Type 5 geotextiles.

Page 10-77, Article 1056-3 CERTIFICATIONS AND IDENTIFICATION, lines 32-35, delete the second paragraph.

Page 10-77, Article 1056-3 CERTIFICATIONS AND IDENTIFICATION, lines 36-41, delete and replace the third paragraph with the following:

Allow the Engineer to visually identify geosynthetic products before installation. Open packaged geosynthetics just before use in the presence of the Engineer to verify the correct product. Geosynthetics that are missing original packaging or product labels or that have been unwrapped or previously opened will be rejected unless otherwise approved by the Engineer.

Page 10-77, Article 1056-4 GEOTEXTILES, lines 43-45, delete the first paragraph.

Page 10-78, Article 1056-4 GEOTEXTILES, before line 1 and lines 1-5, delete Table 1056-1 and lines 1-5 and replace with the following:

TABLE 1056-1 GEOTEXTILE REQUIREMENTS						
Property ^A	Requirement (MARV ^A)					Test Method
	Type 1	Type 2	Type 3 ^B	Type 4	Type 5 ^C	
<i>Typical Application</i>	<i>Shoulder Drains</i>	<i>Under Rip Rap</i>	<i>Silt Fence Fabric</i>	<i>Soil Stabilization</i>	<i>Subgrade Stabilization</i>	
Elongation (MD & CD)	≥ 50%	≥ 50%	≤ 25%	< 50%	< 50%	ASTM D4632
Grab Strength (MD & CD) ^A	Table 1 ^D , Class 3	Table 1 ^D , Class 1	100 lb	Table 1 ^D , Class 3	–	ASTM D4632
Tear Strength (MD & CD) ^A			–			ASTM D4533
Puncture Strength			–			ASTM D6241
Ultimate Tensile Strength (MD & CD) ^A	–	–	–	–	Table 12 ^D , Class 4A	ASTM D4595
Permittivity	Table 2 ^D , 15% to 50% <i>in Situ</i> Soil Passing 0.075 mm	Table 6 ^D , 15% to 50% <i>in Situ</i> Soil Passing 0.075 mm	Table 7 ^D	Table 5 ^D	Table 12 ^D , Class 4A	ASTM D4491
Apparent Opening Size						ASTM D4751
UV Stability (Retained Strength)						ASTM D4355

A. MD, CD and MARV per Article 1056-3.

B. Minimum roll width of 36 inches required.

C. Minimum roll width of 13 feet required unless otherwise approved by the Engineer for the application.

D. Per AASHTO M 288.

Page 10-78, Article 1056-5 GEOCOMPOSITE DRAINS, before line 9 and lines 9-10, delete Table 1056-2 and lines 9-10 and replace with the following:

TABLE 1056-2 GEOCOMPOSITE DRAIN REQUIREMENTS				
Property	Requirement			Test Method
	Sheet Drain	Strip Drain	Wick Drain	
Width	≥ 12"	12" ±1/4"	4" ±1/4"	N/A
In-Plane Flow Rate ^A (with gradient of 1.0 and 24-hour seating period)	6 gpm/ft @ applied normal compressive stress of 10 psi	15 gpm/ft @ applied normal compressive stress of 7.26 psi	1.5 gpm ^B @ applied normal compressive stress of 1.45 psi	ASTM D4716

A. MARV per Article 1056-3.

B. Per foot of width tested.

Page 10-79, Article 1056-5 GEOCOMPOSITE DRAINS, before line 3, delete Table 1056-3 and replace with the following:

TABLE 1056-3 DRAINAGE CORE REQUIREMENTS			
Property	Requirement		Test Method
	Sheet Drain	Strip Drain	
Thickness	1/4"	1"	ASTM D1777 or D5199
Compressive Strength ^A	40 psi	30 psi	ASTM D6364

A. MARV per Article 1056-3.

Page 10-79, Article 1056-5 GEOCOMPOSITE DRAINS, before line 6 and lines 6-11, delete Table 1056-4, lines 6-7 and the last paragraph and replace with the following:

TABLE 1056-4 WICK DRAIN GEOTEXTILE REQUIREMENTS		
Property	Requirement	Test Method
Elongation	≥ 50%	ASTM D4632
Grab Strength	Table 1 ^A , Class 3	ASTM D4632
Tear Strength		ASTM D4533
Puncture Strength		ASTM D6241
Permittivity ^B	0.7 sec ⁻¹	ASTM D4491
Apparent Opening Size (AOS)	Table 2 ^A , > 50% <i>in Situ</i> Soil Passing 0.075 mm	ASTM D4751
UV Stability (Retained Strength)		ASTM D4355

A. Per AASHTO M 288.

B. MARV per Article 1056-3.

For wick drains with a geotextile fused to both faces of a corrugated drainage core along the peaks of the corrugations, use wick drains with an ultimate tensile strength of at least 1,650 lbs. per 4 inch width in accordance with ASTM D4595 and geotextiles with a permittivity, AOS and UV stability that meet Table 1056-4.

Page 10-80, Article 1056-6 GEOCELLS, before line 1 and lines 1-4, delete Table 1056-5 and lines 1-4 and replace with the following:

TABLE 1056-5 GEOCELL REQUIREMENTS		
Property	Requirement	Test Method
Cell Depth	4"	N/A
Fully Expanded Cell Area	100 sq.in. max	N/A
Sheet Thickness	50 mil -5%, +10%	ASTM D5199
Density	58.4 pcf min	ASTM D1505
Carbon Black Content	1.5% min	ASTM D1603 or D4218
ESCR ^A	5000 hr min	ASTM D1693
Coefficient of Direct Sliding (with material that meets AASHTO M 145 for soil classification A-2)	0.85 min	ASTM D5321
Short-Term Seam (Peel) Strength (for 4" seam)	320 lb min	USACE ^C Technical Report GL-86-19, Appendix A
Long-Term Seam (Hang) Strength ^B (for 4" seam)	160 lb min	

A. Environmental Stress Crack Resistance.

B. Minimum test period of 168 hours with a temperature change from 74°F to 130°F in 1-hour cycles.

C. US Army Corps of Engineers (USACE).

TEMPORARY SHORING:

(2-20-07) (Rev. 10-19-21)

SP11 R02

Description

Temporary shoring includes cantilever, braced and anchored shoring and temporary mechanically stabilized earth (MSE) walls. Temporary shoring does not include trench boxes. At the Contractor's option, use any type of temporary shoring unless noted otherwise in the plans or as directed. Design and construct temporary shoring based on actual elevations and shoring dimensions in accordance with the contract and accepted submittals. Construct temporary shoring at locations shown in the plans and as directed. Temporary shoring is required to maintain traffic when a 2:1 (H:V) slope from the top of an embankment or bottom of an excavation will intersect the existing ground line less than 5 feet from the edge of pavement of an open travelway. This provision does not apply to pipe, inlet or utility installation unless noted otherwise in the plans.

Positive protection includes concrete barrier and temporary guardrail. Provide positive protection for temporary shoring at locations shown in the plans and as directed. Positive protection is required if temporary shoring is located in the clear zone in accordance with the *AASHTO Roadside Design Guide*.

(A) Cantilever and Braced Shoring

Cantilever shoring consists of steel sheet piles or H-piles with timber lagging. Braced shoring consists of sheet piles or H-piles with timber lagging and bracing such as beams, plates, walers, struts, rakers, etc. Define "piles" as sheet piles or H-piles.

(B) Anchored Shoring

Anchored shoring consists of sheet piles with walers or H-piles with timber lagging anchored with ground or helical anchors. Driven anchors may be accepted at the discretion of the Engineer. A ground anchor consists of a grouted steel bar or multi-strand tendon with an anchorage. A helical anchor consists of a lead section with a central steel shaft and at least one helix steel plate followed by extensions with only central shafts (no helixes) and an anchorage. Anchorages consist of steel bearing plates with washers and hex nuts for bars or steel wedge plates and wedges for strands. Use a prequalified Anchored Wall Contractor to install ground anchors. Define “anchors” as ground, helical or driven anchors.

(C) Temporary MSE Walls

Temporary MSE walls include temporary geosynthetic and wire walls. Define “temporary wall” as a temporary MSE wall and “Temporary Wall Vendor” as the vendor supplying the temporary MSE wall. Define “reinforcement” as geotextile, geogrid, geostrip, welded wire grid or metallic strip reinforcement.

Temporary geosynthetic walls consist of geotextiles or geogrids wrapped behind welded wire facing or geostrips connected to welded wire facing. Define “temporary geotextile wall” as a temporary geosynthetic wall with geotextile reinforcement, “temporary geogrid wall” as a temporary geosynthetic wall with geogrid reinforcement and “temporary geostrip wall” as a temporary geosynthetic wall with geostrip reinforcement.

Temporary wire walls consist of welded wire grid or metallic strip reinforcement connected to welded wire facing. Define “Wire Wall Vendor” as the vendor supplying the temporary wire wall.

(D) Embedment

Define “embedment” for cantilever, braced and anchored shoring as the pile depth below the grade in front of shoring. Define “embedment” for temporary walls as the wall embedment below the grade at the wall face.

(E) Positive Protection

Define “unanchored or anchored portable concrete barrier” as portable concrete barrier (PCB) that meets 2018 Roadway Standard Drawing No. 1170.01. Define “concrete barrier” as unanchored or anchored PCB or an approved equal. Define “temporary guardrail” as temporary steel beam guardrail that meets 2018 Roadway Standard Drawing No. 862.02.

Materials

Refer to the *2018 Standard Specifications*.

Item	Section
Concrete Barrier Materials	1170-2
Flowable Fill, Excavatable	1000-6
Geosynthetics	1056
Grout, Type 1	1003
Portland Cement	1024-1
Portland Cement Concrete	1000
Select Materials	1016
Steel Beam Guardrail Materials	862-2
Steel Plates	1072-2
Steel Sheet Piles and H-Piles	1084
Untreated Timber	1082-2
Water	1024-4
Welded Wire Reinforcement	1070-3

Provide Type 6 material certifications for shoring materials in accordance with Article 106-3 of the *2018 Standard Specifications*. Use Class IV select material for temporary guardrail and Class A concrete that meets Article 450-2 of the *2018 Standard Specifications* or Type 1 grout for drilled-in piles. Provide untreated timber with a thickness of at least 3 inches and a bending stress of at least 1,000 pounds per square inch for timber lagging. Provide steel bracing that meets ASTM A36.

(A) Shoring Backfill

Use Class II, Type 1, Class III, Class V or Class VI select material or material that meets AASHTO M 145 for soil classification A-2-4 with a maximum PI of 6 for shoring backfill except do not use A-2-4 soil for backfill around culverts.

(B) Anchors

Store anchor materials on blocking a minimum of 12 inches above the ground and protect it at all times from damage; and when placing in the work make sure it is free from dirt, dust, loose mill scale, loose rust, paint, oil or other foreign materials. Load, transport, unload and store anchor materials so materials are kept clean and free of damage. Bent, damaged or defective materials will be rejected.

(1) Ground Anchors

Use high-strength deformed steel bars that meet AASHTO M 275 or seven-wire strands that meet ASTM A886 or Article 1070-5 of the *2018 Standard Specifications*. Splice bars in accordance with Article 1070-9 of the *2018 Standard Specifications*. Do not splice strands. Use bondbreakers, spacers and centralizers that meet Article 6.3.5 of the *AASHTO LRFD Bridge Construction Specifications*.

Use neat cement grout that only contains cement and water with a water cement ratio of 0.4 to 0.5 which is approximately 5.5 gallons of water per 94 pounds of Portland cement. Provide grout with a compressive strength at 3 and 28 days of at

least 1,500 and 4,000 psi, respectively.

(2) Helical Anchors

Use helical anchors with an ICC Evaluation Service, Inc. (ICC-ES) report. Provide couplers, thread bar adapters and bolts recommended by the Anchor Manufacturer to connect helical anchors together and to piles.

(3) Anchorages

Provide steel plates for bearing plates and steel washers, hex nuts, wedge plates and wedges recommended by the Anchor Manufacturer.

(C) Temporary Walls

(1) Welded Wire Facing

Use welded wire reinforcement for welded wire facing, struts and wires. For temporary wire walls, provide welded wire facing supplied by the Wire Wall Vendor or a manufacturer approved or licensed by the vendor. For temporary wire walls with separate reinforcement and facing components, provide connectors (e.g., bars, clamps, plates, etc.) and fasteners (e.g., bolts, nuts, washers, etc.) required by the Wire Wall Vendor.

(2) Geotextiles

Provide Type 2 geotextile for separation and retention geotextiles. Provide Type 5 geotextile for geotextile reinforcement with ultimate tensile strengths in accordance with the accepted submittals.

(3) Geogrid and Geostrip Reinforcement

Use geogrids with a roll width of at least 4 feet. Use geogrids for geogrid reinforcement and geostrips for geostrip reinforcement with an “approved” status code in accordance with the NCDOT Geosynthetic Reinforcement Evaluation Program. The list of approved geogrids and geostrips is available from: connect.ncdot.gov/resources/Geological/Pages/Products.aspx

Provide geogrids and geostrips with design strengths in accordance with the accepted submittals. Geogrids and geostrips are approved for short-term design strengths (3-year design life) in the machine direction (MD) and cross-machine direction (CD) based on material type. Define material type from the website above for shoring backfill as follows:

Material Type	Shoring Backfill
Borrow	A-2-4 Soil
Fine Aggregate	Class II, Type 1 or Class III Select Material
Coarse Aggregate	Class V or VI Select Material

(4) Welded Wire Grid and Metallic Strip Reinforcement

Provide welded wire grid and metallic strip reinforcement supplied by the Wire Wall Vendor or a manufacturer approved or licensed by the vendor. Use welded wire grid reinforcement (“mesh”, “mats” and “ladders”) that meet Article 1070-3 of the *2018 Standard Specifications* and metallic strip reinforcement (“straps”) that meet ASTM A572 or A1011.

Preconstruction Requirements

(A) Concrete Barrier

Define “clear distance” behind concrete barrier as the horizontal distance between the barrier and edge of pavement. The minimum required clear distance for concrete barrier is shown in the plans. At the Contractor’s option or if the minimum required clear distance is not available, set concrete barrier next to and up against traffic side of temporary shoring except for barrier above temporary walls. Concrete barrier with the minimum required clear distance is required above temporary walls.

(B) Temporary Guardrail

Define “clear distance” behind temporary guardrail as the horizontal distance between guardrail posts and temporary shoring. At the Contractor’s option or if clear distance for cantilever, braced and anchored shoring is less than 4 feet, attach guardrail to traffic side of shoring as shown in the plans. Place ABC in clear distance and around guardrail posts instead of pavement. Do not use temporary guardrail above temporary walls.

(C) Temporary Shoring Designs

Before beginning temporary shoring design, survey existing ground elevations in the vicinity of shoring locations to determine actual design heights (H). Submit PDF files of working drawings and design calculations for temporary shoring designs in accordance with Article 105-2 of the *2018 Standard Specifications*. Submit working drawings showing plan views, shoring profiles, typical sections and details of temporary shoring design and construction sequence. Do not begin shoring construction until a design submittal is accepted.

Have cantilever and braced shoring designed, detailed and sealed by an engineer licensed in the state of North Carolina. Use a prequalified Anchored Wall Design Consultant to design anchored shoring. Provide anchored shoring designs sealed by a Design Engineer approved as a Geotechnical Engineer (key person) for an Anchored Wall Design Consultant. Include details in anchored shoring working drawings of anchor locations and lock-off loads, unit grout/ground bond strengths for ground anchors or minimum installation torque and torsional strength rating for helical anchors and if necessary, obstructions extending through shoring or interfering with anchors. Include details in the anchored shoring construction sequence of pile and anchor installation, excavation and anchor testing.

Provide temporary wall designs sealed by a Design Engineer licensed in the state of North Carolina and employed or contracted by the Temporary Wall Vendor. Include details in temporary wall working drawings of geotextile and reinforcement types, locations and directions and obstructions extending through walls or interfering with reinforcement.

(1) Soil Parameters

Design temporary shoring for the assumed soil parameters and groundwater or flood elevations shown in the plans. Assume the following soil parameters for shoring backfill:

(a) Unit weight (γ) = 120 pcf,

(b)	Friction Angle (ϕ)	Shoring Backfill
	30°	A-2-4 Soil
	34°	Class II, Type 1 or Class III Select Material
	38°	Class V or VI Select Material

(c) Cohesion (c) = 0 psf.

(2) Traffic Surcharge

Design temporary shoring for a traffic surcharge of 250 pounds per square foot if traffic will be above and within H of shoring. This traffic surcharge does not apply to construction traffic. Design temporary shoring for any construction surcharge if construction traffic will be above and within H of shoring. Design temporary shoring for a traffic (live load) surcharge in accordance with Article 11.5.6 of the *AASHTO LRFD Bridge Design Specifications*.

(3) Cantilever, Braced and Anchored Shoring Designs

Use shoring backfill for fill sections and voids between cantilever, braced and anchored shoring and the critical failure surface. Use concrete or Type 1 grout for embedded portions of drilled-in H-piles. Do not use drilled-in sheet piles.

Define “top of shoring” for cantilever, braced and anchored shoring as where the grade intersects the back of sheet piles or H-piles and timber lagging. Design cantilever, braced and anchored shoring for a traffic impact load of 2,000 pounds per foot applied 18 inches above top of shoring if concrete barrier is above and next to shoring or temporary guardrail is above and attached to shoring. Extend cantilever, braced and anchored shoring at least 32 inches above top of shoring if shoring is designed for traffic impact. Otherwise, extend shoring at least 6 inches above top of shoring.

Design cantilever, braced and anchored shoring for a maximum deflection of 3 inches if the horizontal distance to the closest edge of pavement or structure is less than H. Otherwise, design shoring for a maximum deflection of 6 inches. Design

cantilever and braced shoring in accordance with the plans and *AASHTO Guide Design Specifications for Bridge Temporary Works*.

Design anchored shoring in accordance with the plans and Article 11.9 of the *AASHTO LRFD Bridge Design Specifications*. Use a resistance factor of 0.80 for tensile resistance of anchors with bars, strands or shafts. Extend the unbonded length for ground anchors and the shallowest helix for helical anchors at least 5 feet behind the critical failure surface. Do not extend anchors beyond right-of-way or easement limits. If existing or future obstructions such as foundations, guardrail posts, pavements, pipes, inlets or utilities will interfere with anchors, maintain a clearance of at least 6 inches between obstructions and anchors.

(4) Temporary Wall Designs

Use shoring backfill in the reinforced zone of temporary walls. Separation geotextiles are required between shoring backfill and backfill, natural ground or culverts along the sides of the reinforced zone perpendicular to the wall face. For Class V or VI select material in the reinforced zone, separation geotextiles are also required between shoring backfill and backfill or natural ground on top of and at the back of the reinforced zone.

Design temporary walls in accordance with the plans and Article 11.10 of the *AASHTO LRFD Bridge Design Specifications*. Embed temporary walls at least 18 inches except for walls on structures or rock as determined by the Engineer. Use a uniform reinforcement length throughout the wall height of at least 0.7H or 6 feet, whichever is longer. Extend the reinforced zone at least 6 inches beyond end of reinforcement. Do not locate the reinforced zone outside right-of-way or easement limits.

Use the simplified method for determining maximum reinforcement loads in accordance with the AASHTO LRFD specifications. For geotextile reinforcement, use geotextile properties approved by the Department or default values in accordance with the AASHTO LRFD specifications. For geogrid and geostrip reinforcement, use approved geosynthetic reinforcement properties available from the website shown elsewhere in this provision. Use geosynthetic properties for the direction reinforcement will be installed, a 3-year design life and shoring backfill to be used in the reinforced zone.

Do not use more than 4 different reinforcement strengths for each temporary geosynthetic wall. Design temporary geotextile walls for a reinforcement coverage ratio (R_c) of 1.0. For temporary geogrid walls with an R_c of less than 1.0, use a maximum horizontal clearance between geogrids of 3 feet and stagger reinforcement so geogrids are centered over gaps in the reinforcement layer below.

For temporary geosynthetic walls, use “L” shaped welded wire facing with 18 to 24 inch long legs. Locate geosynthetic reinforcement so reinforcement layers are at the same level as the horizontal legs of welded wire facing. Use vertical reinforcement spacing equal to facing height. Wrap geotextile or geogrid

reinforcement behind welded wire facing and extend reinforcement at least 3 feet back behind facing into shoring backfill. Attach geostrip reinforcement to welded wire facing with a connection approved by the Department.

For temporary wire walls with separate reinforcement and facing components, attach welded wire grid or metallic strip reinforcement to welded wire facing with a connection approved by the Department. For temporary geogrid, geostrip and wire walls, retain shoring backfill at welded wire facing with retention geotextiles and extend geotextiles at least 3 feet back behind facing into backfill.

(D) Preconstruction Meeting

The Engineer may require a shoring preconstruction meeting to discuss the construction, inspection and testing of the temporary shoring. If required and if this meeting occurs before all shoring submittals have been accepted, additional preconstruction meetings may be required before beginning construction of temporary shoring without accepted submittals. The Resident, District or Bridge Maintenance Engineer, Area Construction Engineer, Geotechnical Operations Engineer, Contractor and Shoring Contractor Superintendent will attend preconstruction meetings.

Construction Methods

Control drainage during construction in the vicinity of shoring. Direct run off away from shoring and shoring backfill. Contain and maintain backfill and protect material from erosion.

Install positive protection in accordance with the contract and accepted submittals. Use PCB in accordance with Section 1170 of the *2018 Standard Specifications* and 2018 Roadway Standard Drawing No. 1170.01. Use temporary guardrail in accordance with Section 862 of the *2018 Standard Specifications* and 2018 Roadway Standard Drawing Nos. 862.01, 862.02 and 862.03.

(A) Tolerances

Construct shoring with the following tolerances:

- (1) Horizontal wires of welded wire facing are level in all directions,
- (2) Shoring location is within 6 inches of horizontal and vertical alignment shown in the accepted submittals, and
- (3) Shoring plumbness (batter) is not negative and within 2 degrees of vertical.

(B) Cantilever, Braced and Anchored Shoring Installation

If overexcavation behind cantilever, braced or anchored shoring is shown in the accepted submittals, excavate before installing piles. Otherwise, install piles before excavating for shoring. Install cantilever, braced or anchored shoring in accordance with the construction sequence shown in the accepted submittals. Remove piles and if applicable, timber lagging

when shoring is no longer needed.

(1) Pile Installation

Install piles with the minimum required embedment and extension in accordance with Subarticles 450-3(D) and 450-3(E) of the *2018 Standard Specifications* except that a pile driving equipment data form is not required. Piles may be installed with a vibratory hammer as approved by the Engineer.

Do not splice sheet piles. Use pile excavation to install drilled-in H-piles. After filling holes with concrete or Type 1 grout to the elevations shown in the accepted submittals, remove any fluids and fill remaining portions of holes with flowable fill. Cure concrete or grout at least 7 days before excavating.

Notify the Engineer if refusal is reached before pile excavation or driven piles attain the minimum required embedment. When this occurs, a revised design submittal may be required.

(2) Excavation

Excavate in front of piles from the top down in accordance with the accepted submittals. For H-piles with timber lagging and braced and anchored shoring, excavate in staged horizontal lifts with a maximum height of 5 feet. Remove flowable fill and material in between H-piles as needed to install timber lagging. Position lagging with at least 3 inches of contact in the horizontal direction between the lagging and pile flanges. Do not excavate the next lift until timber lagging for the current lift is installed and if applicable, bracing and anchors for the current lift are accepted. Backfill behind cantilever, braced or anchored shoring with shoring backfill.

(3) Anchor Installation

If applicable, install foundations located behind anchored shoring before installing anchors. Fabricate and install ground anchors in accordance with the accepted submittals, Articles 6.4 and 6.5 of the *AASHTO LRFD Bridge Construction Specifications* and the following unless otherwise approved:

- (a) Materials in accordance with this provision are required instead of materials conforming to Articles 6.4 and 6.5.3 of the AASHTO LRFD Specifications,
- (b) Encapsulation-protected ground anchors in accordance with Article 6.4.1.2 of the AASHTO LRFD specifications are not required, and
- (c) Corrosion protection for unbonded lengths of ground anchors and anchorage covers are not required.
- (d) Mix and place neat cement grout in accordance with Subarticles 1003-5, 1003-6 and 1003-7 of the *2018 Standard Specifications*. Measure grout

temperature, density and flow during grouting with at least the same frequency grout cubes are made for compressive strength. Perform density and flow field tests in the presence of the Engineer in accordance with American National Standards Institute/American Petroleum Institute Recommended Practice 13B-1 (Section 4, Mud Balance) and ASTM C939 (Flow Cone), respectively.

Install helical anchors in accordance with the accepted submittals and Anchor Manufacturer's instructions. Measure torque during installation and do not exceed the torsional strength rating of the helical anchor. Attain the minimum required installation torque and penetration before terminating anchor installation. When replacing a helical anchor, embed last helix of the replacement anchor at least 3 helix plate diameters past the location of the first helix of the previous anchor.

(4) Anchor Testing

Proof test and lock-off anchors in accordance with the accepted submittals and Article 6.5.5 of the *AASHTO LRFD Bridge Construction Specifications* except for the acceptance criteria in Article 6.5.5.5. For the AASHTO LRFD specifications, "ground anchor" refers to a ground or helical anchor and "tendon" refers to a bar, strand or shaft.

(a) Anchor Acceptance

Anchor acceptance is based in part on the following criteria.

- (i) For ground and helical anchors, total movement is less than 0.04 inches between the 1 and 10 minute readings or less than 0.08 inches between the 6 and 60 minute readings.
- (ii) For ground anchors, total movement at maximum test load exceeds 80% of the theoretical elastic elongation of the unbonded length.

(b) Anchor Test Results

Submit PDF files of anchor test records including movement versus load plots for each load increment within 24 hours of completing each row of anchors. The Engineer will review the test records to determine if the anchors are acceptable.

If the Engineer determines an anchor is unacceptable, revise the anchor design or installation methods. Submit a revised anchored shoring design for acceptance and provide an acceptable anchor with the revised design or installation methods. If required, replace the anchor or provide additional anchors with the revised design or installation methods.

(C) Temporary Wall Installation

Excavate as necessary for temporary walls in accordance with the plans and accepted

submittals. If applicable, install foundations located in the reinforced zone before placing shoring backfill or reinforcement unless otherwise approved. Notify the Engineer when foundation excavation is complete. Do not place shoring backfill or reinforcement until excavation dimensions and foundation material are approved.

Erect welded wire facing so the wall position is as shown in the plans and accepted submittals. Set welded wire facing adjacent to each other in the horizontal and vertical direction to completely cover the wall face with facing. Stagger welded wire facing to create a running bond by centering facing over joints in the row below.

Attach geostrip reinforcement to welded wire facing and wrap geotextile reinforcement and retention geotextiles behind welded wire facing as shown in the plans and accepted submittals. Cover geotextiles with at least 3" of shoring backfill. Overlap adjacent geotextile reinforcement and retention and separation geotextiles at least 18 inches with seams oriented perpendicular to the wall face. Hold geotextiles in place with wire staples or anchor pins as needed.

Place reinforcement within 3 inches of locations shown in the plans and accepted submittals. Before placing shoring backfill, pull geosynthetic reinforcement taut so it is in tension and free of kinks, folds, wrinkles or creases. Install reinforcement with the direction shown in the plans and accepted submittals. For temporary wire walls with separate reinforcement and facing components, attach welded wire grid or metallic strip reinforcement to welded wire facing as shown in the accepted submittals. Do not splice or overlap reinforcement so seams are parallel to the wall face. Contact the Engineer when unanticipated existing or future obstructions such as foundations, pavements, pipes, inlets or utilities will interfere with reinforcement.

Place shoring backfill in the reinforced zone in 8 to 10 inch thick lifts. Compact A-2-4 soil and Class II, Type 1 and Class III select material in accordance with Subarticle 235-3(C) of the *2018 Standard Specifications*. Use only hand operated compaction equipment to compact backfill within 3 feet of welded wire facing. At a distance greater than 3 feet, compact shoring backfill with at least 4 passes of an 8 to 10 ton vibratory roller in a direction parallel to the wall face. Smooth wheeled or rubber tired rollers are also acceptable for compacting backfill. Do not use sheepsfoot, grid rollers or other types of compaction equipment with feet. Do not displace or damage reinforcement when placing and compacting shoring backfill. End dumping directly on geosynthetics is not permitted. Do not operate heavy equipment on reinforcement until it is covered with at least 8 inches of shoring backfill. Replace any damaged reinforcement to the satisfaction of the Engineer.

Backfill for temporary walls outside the reinforced zone in accordance with Article 410-8 of the *2018 Standard Specifications*. Bench temporary walls into the sides of excavations where applicable. For temporary geosynthetic walls with top of wall within 5 feet of finished grade, remove top facing and incorporate top reinforcement layer into fill when placing fill in front of wall. Temporary walls remain in place permanently unless otherwise required.

Measurement and Payment

Temporary Shoring will be measured and paid in square feet. Temporary walls will be measured as the square feet of exposed wall face area. Cantilever, braced or anchored shoring will be measured as the square feet of exposed shoring face area with the shoring height equal to the difference between the top and bottom of shoring elevations. Define “top of shoring” as where the grade intersects the back of sheet piles or H-piles and timber lagging. Define “bottom of shoring” as where the grade intersects front of sheet piles or H-piles and timber lagging. No measurement will be made for any embedment, shoring extension above top of shoring or pavement thickness above temporary walls.

The contract unit price for *Temporary Shoring* will be full compensation for providing shoring designs, submittals and materials, excavating, backfilling, hauling and removing excavated materials and supplying all labor, tools, equipment and incidentals necessary to construct temporary shoring.

No payment will be made for temporary shoring not shown in the plans or required by the Engineer including shoring for OSHA reasons or the Contractor’s convenience. No value engineering proposals will be accepted based solely on revising or eliminating shoring locations shown in the plans or estimated quantities shown in the bid item sheets as a result of actual field measurements or site conditions.

PCB will be measured and paid in accordance with Section 1170 of the *2018 Standard Specifications*. No additional payment will be made for anchoring PCB for temporary shoring. Costs for anchoring PCB will be incidental to temporary shoring.

Temporary guardrail will be measured and paid for in accordance with Section 862 of the *2018 Standard Specifications*.

Payment will be made under:

Pay Item	Pay Unit
Temporary Shoring	Square Foot

MATERIAL AND EQUIPMENT STORAGE & PARKING OF PERSONAL VEHICLES:

11-17-21(Rev. 8-16-22)

1101

SP11 R03

Revise the *2018 Standard Specifications* as follows:

Page 11-2, Article 1101-8 MATERIAL AND EQUIPMENT STORAGE, line 35-38, delete and replace with the following:

When work is not in progress, keep all personnel, equipment, machinery, tools, construction debris, materials and supplies away from active travel lanes that meets Table 1101-1.

TABLE 1101-1 MATERIAL AND EQUIPMENT STORAGE FROM ACTIVE TRAVEL LANES	
Posted Speed Limit (mph)	Distance (ft)
40 or less	≥ 18
45-50	≥ 28
55	≥ 32
60 or higher	≥ 40

When vehicles, equipment and materials are protected by concrete barrier or guardrail, they shall be offset at least 5 feet from the barrier or guardrail.

Page 11-2, Article 1101-9 PARKING OF PERSONAL VEHICLES, line 40-41, delete and replace with the following:

Provide staging areas for personal vehicle parking in accordance with Article 1101-8 or as directed by the Engineer before use.

WORK ZONE INSTALLER:

(7-20-21)(Rev. 8-16-22)

1101, 1150

SP11 R04

Provide the service of at least one qualified work zone installer during the setup, installation, and removal of temporary traffic control within the highway right of way. The qualified work zone installer shall serve as crew leader and shall be on site and directing the installation and removal of temporary traffic control. If multiple temporary traffic control installations or removals are occurring simultaneously, then each shall have a qualified work zone installer.

The work zone installer shall be qualified by an NCDOT approved training agency or other NCDOT approved training provider in the safe and competent set up of temporary traffic control. For a complete listing of approved training agencies, see the Work Zone Safety Training webpage.

A work zone supervisor, in accordance with Article 1101-13 of the *Standard Specifications*, may fulfill the role of the work zone installer during the setup, installation, and removal of temporary traffic control within the highway right of way provided they are on site and directing the installation and removal of temporary traffic control.

All other individuals participating in the setup, installation, and removal of temporary traffic control within the highway right of way shall be certified as a qualified flagger in accordance with Article 1150-3 of the *Standard Specifications*, even if flagging is not being performed as part of the traffic control.

Provide the name and contact information of all qualified work zone installers to the Engineer prior to or at the preconstruction conference. Additionally, provide a qualification statement that all other individuals participating in the setup, installation, and removal of temporary traffic control are qualified flaggers that have been properly trained through an NCDOT approved training agency or other NCDOT approved training provider.

All certification records for qualified work zone installers and flaggers shall be uploaded by the approved training agency or other NCDOT approved training provider to the Department's Work Zone Education Verification App (WZ-EVA) prior to the qualified work zone installer or flagger performing any traffic control duties on the project. For more information about WZ-EVA, see the Work Zone Safety Training webpage.

PORTABLE CHANGEABLE MESSAGE SIGNS:

(9-20-22)(Rev. 11-15-22)

1089, 1120

SP11 R10

Revise the *2018 Standard Specifications* as follows:

Page 10-197, Subarticle 1089-7(D) Controller, line 16, add the following after the third sentence of the first paragraph:

Change the controller password from the factory default and periodically change the controller password to deter unauthorized programming of the controller.

Page 10-197, Subarticle 1089-7(D) Controller, lines 16-19, replace the fourth sentence of the first paragraph with the following:

The password system is recommended to include at least two levels of security such that operators at one level may only change message sequences displayed using preprogrammed sequences and operators at a higher level may create and store messages or message sequences.

Page 10-197, Subarticle 1089-7(D) Controller, line 24 replace the sentence with the following:

The controller shall be stored in a locked, weather and vandal resistant box when not in use and after changes to the messages are made.

Page 11-8, Article 1120-3 CONSTRUCTION METHODS, lines 26-32, replace the second paragraph with the following:

Provide an experienced operator for the portable changeable message sign during periods of operation to ensure that the messages displayed on the sign panel are in accordance with the plans and Subarticle 1089-7(D). Change the controller password from the factory default and periodically change the controller password to deter unauthorized programming of the controller. Using two levels of password security is recommended such that operators at one level may only change message sequences displayed using preprogrammed sequences and operators at a higher level may create and store messages or message sequences. Lock the controller in a weather and vandal resistant box when not in use and after changes to the messages are made.

LAW ENFORCEMENT:

(6-21-22)(Rev. 11-15-22)

1190

SP11 R30

Revise the *2018 Standard Specifications* as follows:

Page 11-19, Article 1190-1 DESCRIPTION, lines 4-5, replace the paragraph with the following:

Furnish Law Enforcement Officers and official Law Enforcement vehicles to direct traffic in accordance with the contract.

Page 11-19, Article 1190-2 CONSTRUCTION METHODS, lines 7-10, replace the first and second paragraph with the following:

Use off duty uniformed Law Enforcement Officers and official Law Enforcement vehicles equipped with blue lights to direct or control traffic as required by the plans or by the Engineer.

Law Enforcement vehicles shall not be parked within the buffer space on any roadway. Law Enforcement vehicles shall not be used to close or block an active travel lane on multilane roadways with a posted speed limit of 45 MPH or higher, except as allowed during rolling roadblock operations as shown in the *Roadway Standard Drawings* or while responding to an emergency.

Page 11-19, Article 1190-3 MEASUREMENT AND PAYMENT, lines 14-15, replace the second sentence of the first paragraph with the following:

There will be no direct payment for official Law Enforcement vehicles as they are considered incidental to the pay item.

EXTRUDED THERMOPLASTIC PAVEMENT MARKING THICKNESS:

3-19-19 (Rev. 6-21-22)

1205

SP12 R05

Revise the *2018 Standard Specifications* as follows:

Page 12-6, Subarticle 1205-4(A)(1) General, lines 5-8, delete the second sentence and replace with the following:

Use application equipment that provides multiple width settings ranging from 4 inches to 12 inches and multiple thickness settings to achieve the required thickness above the surface of the pavement as shown in Table 1205-3.

Page 12-7, Table 1205-3, THICKNESS REQUIREMENTS FOR THERMOPLASTIC, replace with the following:

TABLE 1205-3 MINIMUM THICKNESS REQUIREMENTS FOR THERMOPLASTIC	
Thickness	Location
240 mils	In-lane and shoulder-transverse pavement markings (rumble strips). May be placed in 2 passes.
90 mils	Center lines, skip lines, transverse bands, mini-skip lines, characters, bike lane symbols, crosswalk lines, edge lines, gore lines, diagonals, and arrow symbols

PORTABLE CONSTRUCTION LIGHTING:

4-19-22

1413

SP14 R13

Revise the *2018 Standard Specifications* as follows:

Page 14-24, Article 1413-3 TOWER LIGHT, lines 2-7, delete and replace the first and second sentence in the first paragraph with the following:

Use tower lights which consist of mercury vapor, metal halide, high pressure sodium, low pressure sodium or light emitting diode (with correlated color temperature of 4000 Kelvin or less) fixtures mounted on a tower approximately 30 feet in height. Use tower light fixtures which are heavy duty flood, area, or roadway style with wide beam spread, have sufficient output to provide the minimum illumination requirements for the Category of work, are weatherproof and supplied with attached waterproof power cord and plug.

Page 14-24, Article 1413-3 TOWER LIGHT, lines 11-12, delete and replace the second paragraph with the following:

Provide tower lights of sufficient wattage or quantity to provide the minimum average maintained horizontal illuminance over the work area based on the Category of work as shown in Table 1413-1. For any work not covered in Table 1413-1, provide a minimum average maintained horizontal illuminance of 20.0 footcandles over the work area.

Category	Description of Construction and Maintenance Task	Minimum Average Maintained Horizontal Illuminance
I	Excavation; Embankment, Fill and Compaction; Maintenance of Embankment; Asphalt Pavement Rolling; Subgrade, Stabilization and Construction; Base Course Rolling; Sweeping and Cleaning; Landscaping, Sod and Seeding; Reworking Shoulders.	5.0 footcandle
II	Barrier Wall and Traffic Separators; Milling, Removal of Pavement; Asphalt Paving and Resurfacing; Concrete Pavement; Base Course Grading and Shaping; Surface Treatment; Waterproofing and Sealing; Sidewalk Construction; Guardrails and Fencing; Striping and Pavement Marking; Highway Signs; Bridge Decks; Drainage Structures and Drainage Piping; Other Concrete Structures; Repair of Concrete Pavement; Pothole Filling; Repair of Guardrail and Fencing.	10.0 footcandle
III	Traffic Signals; Highway Lighting Systems; Crack Filling.	20.0 footcandle

Page 14-24, Article 1413-4 MACHINE LIGHTS, lines 18-21, delete and replace the first and second sentence in the first paragraph with the following:

Use machine lights which have mercury vapor, metal halide, high pressure sodium, low pressure sodium or light emitting diode (with correlated color temperature of 4000 Kelvin or less) fixtures mounted on supports attached to the construction machine at a height of approximately 13 feet.

Page 14-24, Article 1413-5 CONSTRUCTION METHODS, lines 33-34, delete and replace the third and fourth sentence in the first paragraph with the following:

Submit photometric calculations showing the minimum average maintained horizontal illuminance over the work area and the tower spacing to the Engineer for review and approval prior to installation.

STANDARD SPECIAL PROVISION
AVAILABILITY OF FUNDS – TERMINATION OF CONTRACTS

(5-20-08)

Z-2

General Statute 143C-6-11. (h) Highway Appropriation is hereby incorporated verbatim in this contract as follows:

(h) Amounts Encumbered. – Transportation project appropriations may be encumbered in the amount of allotments made to the Department of Transportation by the Director for the estimated payments for transportation project contract work to be performed in the appropriation fiscal year. The allotments shall be multiyear allotments and shall be based on estimated revenues and shall be subject to the maximum contract authority contained in *General Statute 143C-6-11(c)*. Payment for transportation project work performed pursuant to contract in any fiscal year other than the current fiscal year is subject to appropriations by the General Assembly. Transportation project contracts shall contain a schedule of estimated completion progress, and any acceleration of this progress shall be subject to the approval of the Department of Transportation provided funds are available. The State reserves the right to terminate or suspend any transportation project contract, and any transportation project contract shall be so terminated or suspended if funds will not be available for payment of the work to be performed during that fiscal year pursuant to the contract. In the event of termination of any contract, the contractor shall be given a written notice of termination at least 60 days before completion of scheduled work for which funds are available. In the event of termination, the contractor shall be paid for the work already performed in accordance with the contract specifications.

Payment will be made on any contract terminated pursuant to the special provision in accordance with Subarticle 108-13(D) of the *2018 Standard Specifications*.

STANDARD SPECIAL PROVISION
NCDOT GENERAL SEED SPECIFICATION FOR SEED QUALITY

(5-17-11)

Z-3

Seed shall be sampled and tested by the North Carolina Department of Agriculture and Consumer Services, Seed Testing Laboratory. When said samples are collected, the vendor shall supply an independent laboratory report for each lot to be tested. Results from seed so sampled shall be final. Seed not meeting the specifications shall be rejected by the Department of Transportation and shall not be delivered to North Carolina Department of Transportation warehouses. If seed has been delivered it shall be available for pickup and replacement at the supplier's expense.

Any re-labeling required by the North Carolina Department of Agriculture and Consumer Services, Seed Testing Laboratory, that would cause the label to reflect as otherwise specified herein shall be rejected by the North Carolina Department of Transportation.

Seed shall be free from seeds of the noxious weeds Johnsongrass, Balloonvine, Jimsonweed, Witchweed, Itchgrass, Serrated Tussock, Showy Crotalaria, Smooth Crotalaria, Sicklepod, Sandbur, Wild Onion, and Wild Garlic. Seed shall not be labeled with the above weed species on the seed analysis label. Tolerances as applied by the Association of Official Seed Analysts will NOT be allowed for the above noxious weeds except for Wild Onion and Wild Garlic.

Tolerances established by the Association of Official Seed Analysts will generally be recognized. However, for the purpose of figuring pure live seed, the found pure seed and found germination percentages as reported by the North Carolina Department of Agriculture and Consumer Services, Seed Testing Laboratory will be used. Allowances, as established by the NCDOT, will be recognized for minimum pure live seed as listed on the following pages.

The specifications for restricted noxious weed seed refers to the number per pound as follows:

<u>Restricted Noxious Weed</u>	<u>Limitations per Lb. Of Seed</u>	<u>Restricted Noxious Weed</u>	<u>Limitations per Lb. of Seed</u>
Blessed Thistle	4 seeds	Cornflower (Ragged Robin)	27 seeds
Cocklebur	4 seeds	Texas Panicum	27 seeds
Spurred Anoda	4 seeds	Bracted Plantain	54 seeds
Velvetleaf	4 seeds	Buckhorn Plantain	54 seeds
Morning-glory	8 seeds	Broadleaf Dock	54 seeds
Corn Cockle	10 seeds	Curly Dock	54 seeds
Wild Radish	12 seeds	Dodder	54 seeds
Purple Nutsedge	27 seeds	Giant Foxtail	54 seeds
Yellow Nutsedge	27 seeds	Horsenettle	54 seeds
Canada Thistle	27 seeds	Quackgrass	54 seeds
Field Bindweed	27 seeds	Wild Mustard	54 seeds
Hedge Bindweed	27 seeds		

Seed of Pensacola Bahiagrass shall not contain more than 7% inert matter, Kentucky Bluegrass, Centipede and Fine or Hard Fescue shall not contain more than 5% inert matter whereas a maximum of 2% inert matter will be allowed on all other kinds of seed. In addition, all seed shall

not contain more than 2% other crop seed nor more than 1% total weed seed. The germination rate as tested by the North Carolina Department of Agriculture shall not fall below 70%, which includes both dormant and hard seed. Seed shall be labeled with not more than 7%, 5% or 2% inert matter (according to above specifications), 2% other crop seed and 1% total weed seed.

Exceptions may be made for minimum pure live seed allowances when cases of seed variety shortages are verified. Pure live seed percentages will be applied in a verified shortage situation. Those purchase orders of deficient seed lots will be credited with the percentage that the seed is deficient.

FURTHER SPECIFICATIONS FOR EACH SEED GROUP ARE GIVEN BELOW:

Minimum 85% pure live seed; maximum 1% total weed seed; maximum 2% total other crop seed; maximum 144 restricted noxious weed seed per pound. Seed less than 83% pure live seed will not be approved.

Sericea Lespedeza
Oats (seeds)

Minimum 80% pure live seed; maximum 1% total weed seed; maximum 2% total other crop; maximum 144 restricted noxious weed seed per pound. Seed less than 78% pure live seed will not be approved.

Tall Fescue (all approved varieties)	Bermudagrass
Kobe Lespedeza	Browntop Millet
Korean Lespedeza	German Millet – Strain R
Weeping Lovegrass	Clover – Red/White/Crimson
Carpetgrass	

Minimum 78% pure live seed; maximum 1% total weed seed; maximum 2% total other crop seed; maximum 144 restricted noxious weed seed per pound. Seed less than 76% pure live seed will not be approved.

Common or Sweet Sundangrass

Minimum 76% pure live seed; maximum 1% total weed seed; maximum 2% total other crop seed; maximum 144 restricted noxious weed seed per pound. Seed less than 74% pure live seed will not be approved.

Rye (grain; all varieties)
Kentucky Bluegrass (all approved varieties)
Hard Fescue (all approved varieties)
Shrub (bicolor) Lespedeza

Minimum 70% pure live seed; maximum 1% total weed seed; maximum 2% total other crop seed; maximum 144 noxious weed seed per pound. Seed less than 70% pure live seed will not be approved.

Centipedegrass	Japanese Millet
Crownvetch	Reed Canary Grass
Pensacola Bahiagrass	Zoysia
Creeping Red Fescue	

Minimum 70% pure live seed; maximum 1% total weed seed; maximum 2% total other crop seed; maximum 5% inert matter; maximum 144 restricted noxious weed seed per pound.

Barnyard Grass
Big Bluestem
Little Bluestem
Bristly Locust
Birdsfoot Trefoil
Indiangrass
Orchardgrass
Switchgrass
Yellow Blossom Sweet Clover

STANDARD SPECIAL PROVISION**ERRATA**

(10-16-18) (Rev. 6-20-23)

Z-4

Revise the *2018 Standard Specifications* as follows:

Division 1

Page 1-1, Article 101-2 Abbreviations, line 13, replace " American National Standards Institute, Inc." with "American National Standards Institute".

Page 1-1, Article 101-2 Abbreviations, line 32, replace "Equivalent Single Axis Load" with "Equivalent Single Axle Load".

Page 1-16, Subarticle 102-9(A) General, line 26, replace "10 U.S.C. 2304(g)" with "10 U.S.C. 3205".

Page 1-43, Article 104-13 RECYCLED PRODUCTS OR SOLID WASTE MATERIALS, line 4, replace "104-13(B)(2)" with "104-13(B)".

Page 1-52, Article 106-1 RECYCLED PRODUCTS OR SOLID WASTE MATERIALS, line 25, replace "13 NCAC 7CF.0101(a)(99)" with "29 CFR 1910.1200".

Page 1-79, Article 109-1 MEASUREMENT AND PAYMENT, Test Method prior to line 34, replace "AASHTO M 32" with "AASHTO M 336".

Division 2

Page 2-5, Article 210-2 CONSTRUCTION METHODS, line 21, replace " NCGS §§ 130A-444 to -452" with "NCGS §§ 130A-444 to -453".

Page 2-13, Article 225-2 EROSION CONTROL REQUIREMENTS, line 17, replace "the Sedimentation and Pollution Control Act" with "Article 107-12".

Page 2-20, Subarticle 230-4(B)(3) Reclamation Plan, line 12, replace " Department's borrow and waste site reclamation procedures for contracted projects" with "Department's *Borrow Waste and Staging Site Reclamation Procedures for Contract Projects*".

Page 2-25, Subarticle 235-3(E) Surcharges and Waiting Periods, line 21 and 27, delete "Department's Materials and Tests Unit."

Page 2-27, Article 240-4 MEASUREMENT AND PAYMENT, line 23, replace "Section 225" with "Article 225-7".

Page 2-30, Article 275-4 MEASUREMENT AND PAYMENT, line 33, replace "Section 815" with "Article 815-4".

Division 4

Page 4-18, Subarticle 411-5(C)(3) Coring, line 11, replace "in accordance with ASTM D5079" with "with methods acceptable to the Engineer".

Page 4-50, Article 430-2 MATERIALS, prior to line 15, replace Section “1080-9” with “1080-7”.

Page 4-53, Article 440-2 MATERIALS, prior to line 6, replace Section “1080-9” with “1080-7”.

Page 4-58, Article 442-2 MATERIALS, prior to line 15, replace Section “1080-6” with “1080-12”.

Page 4-59, Subarticle 442-7(A) Blast Cleaning, line 36, replace Article “1080-6” with “1080-12”.

Page 4-76, Article 454-2 MATERIALS, prior to line 24, replace Section “815-2” with “1044”.

Page 4-79, Article 455-2 MATERIALS, prior to line 21, replace Section “815” with “1044”.

Page 4-80, Subarticle 455-3(B) Precast Gravity Wall Designs, line 23 and lines 25-26, replace “AASHTO LRFD specifications” with “*AASHTO LRFD Bridge Design Specifications*”.

Page 4-84, Article 458-5 MEASUREMENT AND PAYMENT, line 31, replace article number “454-1” with “458-1”.

Division 6

Page 6-7, Article 609-1 DESCRIPTION, line 29, replace article number “609-10” with “609-9”.

Page 6-10, Subarticle 609-6(C) Control Charts, line 17, replace Section number “7021” with “7.20.1”.

Page 6-13, Article 609-9 QUALITY ASSURANCE, line 31, replace Section number “7.60” with “7.6”.

Page 6-26, Subarticle 610-13(A)(1) Acceptance for New Construction, line 31, replace Table number “610-7” with “610-8”.

Page 6-29, Subarticle 610-13(B) North Carolina Hearne Straightedge, line 32, replace Table number “610-8” with “610-9”.

Page 6-31, Article 610-14 DENSITY ACCEPTANCE, Specified Density prior to line 30 and line 32, replace Table number “610-6” with “610-7”.

Page 6-37, Article 650-5 CONSTRUCTION METHODS, line 10, replace Section number “9.5(E)” with “9.5.1(E)”.

Page 6-44, Subarticle 660-8(B) Asphalt Mat and Seal, line 40, replace Subarticle number “660-8(A)” with “660-8(C)”.

Page 6-44, Subarticle 660-8(B) Asphalt Mat and Seal, line 42, replace Subarticle number “660-8(C)” with “660-8(A)”.

Division 7

Page 7-11, Subarticle 700-15(E) Compressive Strength, line 5, replace “AASHTO T 23” with “AASHTO R 100”.

Page 7-24, Article 723-4 Very High Early Strength Concrete for Concrete Pavement Repair, line 4, replace “AASHTO T126” with “AASHTO R 39”.

Page 7-24, Article 723-5 MEASUREMENT AND PAYMENT, line 34, replace "Section 225" with “Article 225-7”.

Page 7-24, Article 723-5 MEASUREMENT AND PAYMENT, line 36, replace "Section 270" with “Article 270-4”.

Page 7-27, Article 725-1 MEASUREMENT AND PAYMENT, line 4, replace article number “725-1” with “724-4”.

Page 7-28, Article 725-1 MEASUREMENT AND PAYMENT, line 10, replace article number “725-1” with “725-3”.

Division 8

Page 8-11, Article 815-1 MATERIALS, after line 35, replace “1080-12” with “1080-10”.

Page 8-13, Article 816-1 MATERIALS, after line 28, replace “1080-12” with “1080-10”.

Page 8-17, Article 825-1 Description, line 5, delete “853” and “855”.

Division 10

Page 10-2, Subarticle 1000-3(B) Air Entrainment, line 33, replace “Chase” with “Chace”.

Page 10-4, Subarticle 1000-4(A) Composition and Design, after line 17, replace “T23” with “R100”.

Page 10-4, Subarticle 1000-4(B) Air Entrainment, line 31 and 33, replace “Chase” with “Chace”.

Page 10-4, Subarticle 1000-4(C) Strength of Concrete, line 39 and 41, replace “T 23” with “R 100”.

Page 10-15, Subarticle 1000-11(B) Mixing Time for Central Mixed Concrete, after line 35, replace “T 23” with “R 100”.

Page 10-22, Article 1003-3 COMPOSITION AND DESIGN, line 9, replace “Engineer” with “engineer”.

Page 10-23, Article 1003-4 GROUT REQUIREMENTS, line 16 and 18, replace “T 23” with “R 100”.

Page 10-26, Article 1005-4 TESTING, after line 26, replace “1014-2€(6)” with “1014-2€(6)” in C. of Table 1005-1 footnote and replace “Lightweight^B” with “Lightweight^C”.

Page 10-29, Subarticle 1012-1(B)(4) Flat and Elongated Pieces, line 44, delete “SF9.5A”

Page 10-36, Subarticle 1012-2(E) Toughness (Resistance to Abrasion), line 31, replace “course” with “coarse”.

Page 10-37, Article 1012-4, LIGHTWEIGHT AGGREGATE, line 4, replace Table number “1012-8” with “1012-5”.

Page 10-48, Subarticle 1020-10(A) Mineral Fibers, line 27, replace “Table 1012-5” with “Table 1020-2”.

Page 10-52, Article 1024-5 FLY ASH, line 12, replace “Table 2” with “Table 3”.

Page 10-60, Subarticle 1032-6(F) Joint Materials, line 15, replace “AASHTO M 198” with “ASTM C990” and delete “Type B”.

Page 10-61, Article 1034-3 CONCRETE SEWER PIPE, line 33, replace “AASHTO M 198” with “ASTM C990” and delete “Type A or B”.

Page 10-64, Article 1040-1 BRICK, line 12, replace “ASTM C62” with “ASTM C62 or ASTM C216”.

Page 10-67, Article 1044-7 CORRUGATED PLASTIC PIPE AND FITTINGS, line 24, replace “AASHTO M 294 for heavy duty tubing” with “Article 1032-7 and AASHTO M 252”.

Page 10-68, Subarticle 1046-3(D) Offset Blocks, lines 30-32, delete “Before beginning the installation of recycled offset block, submit the FHWA acceptance letter for each type of block to the Engineer for approval.”

Page 10-69, Subarticle 1046-3(D) Offset Blocks, before line 1, replace “WIRE DIAMETER” with “COMPOSITE OFFSET BLOCKS” as the title of Table 1046-1, delete “Testing” property and associated requirement from Table 1046-1, and replace “Approval” requirement of “Approved for use by the FHWA” with “Approved for use on the NCDOT APL” in Table 1046-1.

Page 10-80, Article 1060-2 FERTILIZER, line 18, replace “North Carolina Fertilizer Law” with “North Carolina Commercial Fertilizer Law”.

Page 10-83, Article 1060-9 WATER, line 9, replace “15 NCAC 2B.0200” with “15A NCAC 02B.0200”.

Page 10-86, Article 1070-3 COLD DRAWN STEEL WIRE AND WIRE REINFORCEMENT, line 23 and 25, replace “M 32” and “M 55” with “M 336”.

Page 10-87, Article 1070-6 DOWELS AND TIE BARS FOR PORTLAND CEMENT CONCRETE PAVEMENT, line 17, replace “AASHTO M 32” with “AASHTO M 336”.

Page 10-88, Subarticle 1070-7(D) Handling, Storage and Transportation, line 40, replace “Section” with “Subarticle”.

Page 10-89, Article 1070-8 SPIRAL COLUMN REINFORCING STEEL, line 21, replace “AASHTO M 32” with “AASHTO M 336”.

Page 10-91, Article 1072-3 BEARING PLATE ASSEMBLIES, line 44, replace “Article 1080-9” with “Article 1080-7”.

Page 10-92, Subarticle 1072-5(A) General, after line 30, replace “SAMPLING REQUIREMENTS FOR HIGH STRENGTH BOLTS, NUTS AND WASHERS” with “SAMPLING REQUIREMENTS FOR HIGH STRENGTH BOLTS, NUTS AND WASHERS TO INCLUDE DIRECT TENSION INDICATORS” as the title of Table 1072-1.

Page 10-95, Subarticle 1072-5(D)(7)(a) Mill Test Report(s), line 18, replace title with “Mill Test Report(s) (MTR)”.

Page 10-95, Subarticle 1072-5(D)(7)(b) Manufacturer Certified Test Report(s), line 24, replace title with “Manufacturer Certified Test Report(s) (MCTR)”.

Page 10-96, Subarticle 1072-5(D)(7)(c) Distributor Certified Test Report(s), line 1, replace title with “Distributor Certified Test Report(s) (DCTR)”.

Page 10-98, Subarticle 1072-5(F) Galvanized High Strength Bolts, Nuts and Washers, line 11, replace “Article 1080-9” with “Article 1080-7”.

Page 10-111, Subarticle 1072-18(B) General, line 24, replace “Structural Welding Code-Reinforcing Steel” with “Structural Welding Code-Steel Reinforcing Bars”.

Page 10-117, Article 1074-1 WELDING, lines 21-22, replace “Structural Welding Code-Reinforcing Steel” with “Structural Welding Code-Steel Reinforcing Bars”.

Page 10-119, Article 1074-7(B) Gray Iron Castings, line 16, replace “M306” with “AASHTO M 306”.

Page 10-121, Article 1076-7, REPAIR OF GALVANIZING, line 8, replace article number “1080-9” with “1080-7”.

Page 10-125, Subarticle 1077-5(B) Testing, line 31, replace “T 23” with “R 100”.

Page 10-131, Subarticle 1078-4(A) Composition and Design, after line 23, in Table 1078-2 replace “T 23” with “R 100”.

Page 10-135, Subarticle 1078-4(J)(2) Mixing Time for Central Mixed Concrete, line 46, replace “Table 1078-2” with “Table 1078-3”

Page 10-136, Subarticle 1078-4(J)(2) Mixing Time for Central Mixed Concrete, after line 17, replace “T23” with “R100”.

Page 10-153, Subarticle 1079-1 PREFORMED BEARING PADS, line 8, replace “MIL-C882-D” with “MIL-C-882-E”.

Page 10-154, Subarticle 1079-2(A) General, line 6, delete “and 1079-2(E)”.

Page 10-156, Article 1080-5 SELF-CURING INORGANIC ZINC PAINT, line 8, replace “AASHTO M 252” with “AASHTO M 300”.

Page 10-156, Article 1080-5 SELF-CURING INORGANIC ZINC PAINT, line 20, replace “AASHTO M 253” with “AASHTO M 300”.

Page 10-156, Subarticle 1080-9(A) Composition, line 40, replace “Tables 1080-7 through 1080-14” with “Tables 1080-1 through 1080-3”.

Page 10-157, Subarticle 1080-9(B) Properties, line 5, replace “Tables 1080-7 through 1080-14” with “Tables 1080-1 through 1080-3”.

Page 10-157, Subarticle 1080-9(B) Properties, line 35, replace “Materials and Tests Standards CLS-P-1.0” with “*Structural Steel Shop Coatings Program*”.

Page 10-159, Subarticle 1080-9(E) Color Variation, Table 1080-1, replace “ASTM D1159” with “ASTM D1199”.

Page 10-159, Subarticle 1080-9(E) Color Variation, Table 1080-1, replace “NCDOT M&T P-10” with “ASTM D6280”.

Page 10-161, Subarticle 1080-9(E) Color Variation, Table 1080-3, replace “ASTM D13278” and “ASTM D3278”.

Page 10-161, Subarticle 1080-9(E) Color Variation, Table 1080-3, replace “NCDOT M&T P-10” and “Structural Steel Shop Coatings Program”.

Page 10-161, Subarticle 1080-9(E) Color Variation, Table 1080-3, add Test Method “ASTM D4400” for the Leneta Sag Test property in Table 1080-3.

Page 10-161, Subarticle 1080-9(E) Color Variation, Table 1080-3, add Test Method “ASTM D523” for the Gloss, Specular property in Table 1080-3.

Page 10-161, Subarticle 1080-9(E) Color Variation, Table 1080-3, replace Test Method “ASTM” with “ASTM E70” for the pH property in Table 1080-3.

Page 10-162, Article 1080-50 PAINT FOR VERTICAL MARKERS, line 1, replace article number “1080-50” with “1080-10”.

Page 10-162, Article 1080-61 EPOXY RESIN FOR REINFORCING STEEL, line 5, replace article number “1080-61” with “1080-11”.

Page 10-162, Article 1080-72 ABRASIVE MATERIALS FOR BLAST CLEANING STEEL, line 22, replace article number “1080-72” with “1080-12”.

Page 10-163, Article 1080-83 FIELD PERFORMANCE AND SERVICES, line 25, replace article number “1080-83” with “1080-13”.

Page 10-166, Subarticle 1081-1(E) Prequalification, line 24, replace “Value Management Unit” with “Product Evaluation Program”.

Page 10-168, Subarticle 1081-3(A) Physical Requirements, after line 25, replace “Subarticle 1081-4(B)” with “Subarticle 1081-3(B)” in Table 1081-2.

Page 10-168, Subarticle 1087-2(A) Paint Composition, lines 19-20, replace “Federal Specification TTP 1952F” with “Federal Specification TT-P-1952”.

Page 10-200, Subarticle 1090-1(C) Anchor Bolts, line 38, replace ASTM number “A325” with “F3125”.

Page 10-202, Subarticle 1091-3(F) Solid Wall HDPE Conduit, line 5, replace “, Table 1091-1, 1091-2 and 1091-3” with “and Table 1091-1”.

Page 10-208, Subarticle 1094-1(A) Breakaway or Simple Steel Beam Sign Supports, line 19, replace ASTM number “A325” with “F3125”.

Page 10-209, Subarticle 1094-1(D) Steel Square Tube Posts, line 10, replace ASTM number “A123” with “A653”.

Page 10-209, Subarticle 1094-1(E) Wood Supports, line 17, replace “Article 1082-2 and 1082-3” with “Section 1082”.

Page 10-212, Subarticle 1098-1(H) Electrical Service, line 21, replace “NEMA Type 3R” with “NEMA 3R”.

Page 10-212, Subarticle 1098-1(H) Electrical Service, line 36, replace “UL Standard 231” with “UL Standard UL-231”.

Page 10-212, Subarticle 1098-1(H) Electrical Service, line 37, replace “UL Standard 67” with “UL Standard UL-67”.

Page 10-224, Subarticle 1098-14(H)(1) Type I – Pedestrian Pushbutton Post, line 3, replace ASTM number “325” with “F3125”.

Page 10-224, Article 1098-16 CABINET BASE ADAPTER/EXTENDER, line 33, replace Section number “6.7” with “6.8”.

Division 14

Page 14-11, Subarticle 1401-2(B) Lowering Device, line 36, replace Military Specification “MIL-W-83420E” with “MIL-DTL-83420”.

Page 14-22, Article 1412-2 MATERIALS, line 29, replace UL Standard “1572” with “1598”.

Division 15

Page 15-6, Subarticle 1510-3(B) Testing and Sterilization, line 40, replace Section number “4.4.3” with “4.4”.

Page 15-14, Article 1525-2 MATERIALS, line 9, replace “AASHTO M 198” with “ASTM C990”.

Page 15-14, Article 1525-2 MATERIALS, lines 17-18, delete “in the Grout Production and Delivery provision”.

Page 15-19, Article 1550-2 MATERIALS, line 16, replace “*AASHTO LRFD Bridge Design Specifications*” with “*AASHTO LRFD Bridge Construction Specifications*”.

Division 16

Page 16-9, Article 1630-3 MEASUREMENT AND PAYMENT, line 7, replace "Section 225" with “Article 225-7”.

Page 16-9, Article 1630-3 MEASUREMENT AND PAYMENT, line 8, replace "Section 230" with “Article 230-5”.

Page 16-16, Article 1637-5 MEASUREMENT AND PAYMENT, line 17, replace "Section 310" with “Article 310-6”.

Division 17

Page 17-15, Article 1715-4 MEASUREMENT AND PAYMENT, lines 42-44, replace the second sentence with the following:

An example is an installation of a single 1.25 inch HDPE conduit would be paid as:

Directional Drill (1)(1.25") Linear Foot

Page 17-15, Subarticle 1715-3(E) Bore and Jack, line 5, replace article number “1540-4” with “1550-4”.

Page 17-15, Subarticle 1715-3(E) Bore and Jack, lines 10 & 11, replace "*NCDOT Policies and Procedures for Accommodating Utilities on Highway Rights of Way*" with “*NCDOT Utilities Accommodations Manual*”.

STANDARD SPECIAL PROVISION**PLANT AND PEST QUARANTINES****(Imported Fire Ant, Gypsy Moth, Witchweed, Emerald Ash Borer, Guava Root Knot Nematode, And Other Noxious Weeds)**

(3-18-03) (Rev. 5-21-19)

Z-04a

Within Quarantined Area

This project may be within a county regulated for plant and/or pests. If the project or any part of the Contractor's operations is located within a quarantined area, thoroughly clean all equipment prior to moving out of the quarantined area. Comply with federal/state regulations by obtaining a certificate or limited permit for any regulated article moving from the quarantined area.

Originating in a Quarantined County

Obtain a certificate or limited permit issued by the N.C. Department of Agriculture/United States Department of Agriculture. Have the certificate or limited permit accompany the article when it arrives at the project site.

Contact

Contact the N.C. Department of Agriculture/United States Department of Agriculture at 1-800-206-9333, 919-707-3730, or <https://www.ncagr.gov/plantindustry/Plant/quaran/table2.htm> to determine those specific project sites located in the quarantined area or for any regulated article used on this project originating in a quarantined county.

Regulated Articles Include

1. Soil, sand, gravel, compost, peat, humus, muck, and decomposed manure, separately or with other articles. This includes movement of articles listed above that may be associated with cut/waste, ditch pulling, and shoulder cutting.
2. Plants with roots including grass sod.
3. Plant crowns and roots.
4. Bulbs, corms, rhizomes, and tubers of ornamental plants.
5. Hay, straw, fodder, and plant litter of any kind.
6. Clearing and grubbing debris.
7. Used agricultural cultivating and harvesting equipment.
8. Used earth-moving equipment.
9. Any other products, articles, or means of conveyance, of any character, if determined by an inspector to present a hazard of spreading imported fire ant, gypsy moth, witchweed, emerald ash borer, guava root knot nematode, or other noxious weeds.

STANDARD SPECIAL PROVISION

MINIMUM WAGES

(7-21-09)

Z-5

FEDERAL: The Fair Labor Standards Act provides that with certain exceptions every employer shall pay wages at the rate of not less than SEVEN DOLLARS AND TWENTY FIVE CENTS (\$7.25) per hour.

STATE: The North Carolina Minimum Wage Act provides that every employer shall pay to each of his employees, wages at a rate of not less than SEVEN DOLLARS AND TWENTY FIVE CENTS (\$7.25) per hour.

The minimum wage paid to all skilled labor employed on this contract shall be SEVEN DOLLARS AND TWENTY FIVE CENTS (\$7.25) per hour.

The minimum wage paid to all intermediate labor employed on this contract shall be SEVEN DOLLARS AND TWENTY FIVE CENTS (\$7.25) per hour.

The minimum wage paid to all unskilled labor on this contract shall be SEVEN DOLLARS AND TWENTY FIVE CENTS (\$7.25) per hour.

This determination of the intent of the application of this act to the contract on this project is the responsibility of the Contractor.

The Contractor shall have no claim against the Department of Transportation for any changes in the minimum wage laws, Federal or State. It is the responsibility of the Contractor to keep fully informed of all Federal and State Laws affecting his contract.

STANDARD SPECIAL PROVISION**TITLE VI AND NONDISCRIMINATION:**

(6-28-77)(Rev 6/19/2018)

Z-6

Revise the *2018 Standard Specifications* as follows:

Replace Article 103-4(B) with the following:

The North Carolina Department of Transportation is committed to carrying out the U.S. Department of Transportation's policy of ensuring nondiscrimination in the award and administration of contracts.

The provisions of this section related to United States Department of Transportation (US DOT) Order 1050.2A, Title 49 Code of Federal Regulations (CFR) part 21, 23 United States Code (U.S.C.) 140 and 23 CFR part 200 (or 49 CFR 303, 49 U.S.C. 5332 or 49 U.S.C. 47123) are applicable to all North Carolina Department of Transportation (NCDOT) contracts and to all related subcontracts, material supply, engineering, architectural and other service contracts, regardless of dollar amount. Any Federal provision that is specifically required not specifically set forth is hereby incorporated by reference.

(1) **Title VI Assurances (USDOT Order 1050.2A, Appendix A)**

During the performance of this contract, the contractor, for itself, its assignees, and successors in interest (hereinafter referred to as the "contractor") agrees as follows:

(a) Compliance with Regulations

The contractor (hereinafter includes consultants) shall comply with the Acts and the Regulations relative to Nondiscrimination in Federally-assisted programs of the U.S. Department of Transportation, Federal Highway Administration (FHWA), as they may be amended from time to time, which are herein incorporated by reference and made a part of this contract.

(b) Nondiscrimination

The contractor, with regard to the work performed by it during the contract, shall not discriminate on the grounds of race, color, or national origin in the selection and retention of subcontractors, including procurements of materials and leases of equipment. The contractor shall not participate directly or indirectly in the discrimination prohibited by the Acts and the Regulations, including employment practices when the contract covers any activity, project, or program set forth in Appendix B of 49 CFR Part 21.

(c) Solicitations for Subcontractors, Including Procurements of Materials and Equipment

In all solicitations, either by competitive bidding, or negotiation made by the contractor for work to be performed under a subcontract, including procurements of materials, or leases of equipment, each potential subcontractor or supplier shall be notified by the contractor of the contractor's obligations under this contract and the Acts and the Regulations relative to Nondiscrimination on the grounds of race, color, or national origin.

(d) Information and Reports

The contractor shall provide all information and reports required by the Acts, the Regulations, and directives issued pursuant thereto and shall permit access to its books, records, accounts, other sources of information, and its facilities as may be determined by the Recipient or the FHWA to be pertinent to ascertain compliance with such Acts,

Regulations, and instructions. Where any information required of a contractor is in the exclusive possession of another who fails or refuses to furnish the information, the contractor shall so certify to the Recipient or the FHWA, as appropriate, and shall set forth what efforts it has made to obtain the information.

(e) Sanctions for Noncompliance:

In the event of a contractor's noncompliance with the Non-discrimination provisions of this contract, the Recipient will impose such contract sanctions as it and/or the FHWA may determine to be appropriate, including, but not limited to:

- (i) Withholding payments to the contractor under the contract until the contractor complies; and/or
- (ii) Cancelling, terminating, or suspending a contract, in whole or in part.

(f) Incorporation of Provisions

The contractor shall include the provisions of paragraphs (a) through (f) in every subcontract, including procurements of materials and leases of equipment, unless exempt by the Acts, the Regulations and directives issued pursuant thereto. The contractor shall take action with respect to any subcontract or procurement as the Recipient or the FHWA may direct as a means of enforcing such provisions including sanctions for noncompliance. Provided, that if the contractor becomes involved in, or is threatened with litigation by a subcontractor, or supplier because of such direction, the contractor may request the Recipient to enter into any litigation to protect the interests of the Recipient. In addition, the contractor may request the United States to enter into the litigation to protect the interests of the United States.

(2) **Title VI Nondiscrimination Program (23 CFR 200.5(p))**

The North Carolina Department of Transportation (NCDOT) has assured the USDOT that, as a condition to receiving federal financial assistance, NCDOT will comply with Title VI of the Civil Rights Act of 1964 and all requirements imposed by Title 49 CFR part 21 and related nondiscrimination authorities to ensure that no person shall, on the ground of race, color, national origin, limited English proficiency, sex, age, or disability (including religion/creed or income-level, where applicable), be excluded from participation in, be denied the benefits of, or be subjected to discrimination under any programs, activities, or services conducted or funded by NCDOT. Contractors and other organizations under contract or agreement with NCDOT must also comply with Title VI and related authorities, therefore:

(a) During the performance of this contract or agreement, contractors (e.g., subcontractors, consultants, vendors, prime contractors) are responsible for complying with NCDOT's Title VI Program. Contractors are not required to prepare or submit Title VI Programs. To comply with this section, the prime contractor shall:

1. Post NCDOT's Notice of Nondiscrimination and the Contractor's own Equal Employment Opportunity (EEO) Policy in conspicuous locations accessible to all employees, applicants and subcontractors on the jobsite.
2. Physically incorporate the required Title VI clauses into all subcontracts on federally-assisted and state-funded NCDOT projects, and ensure inclusion by subcontractors into all lower-tier subcontracts.
3. Required Solicitation Language. The Contractor shall include the following notification in all solicitations for bids and requests for work or material, regardless of funding source:

"The North Carolina Department of Transportation, in accordance with the provisions of Title VI of the Civil Rights Act of 1964 (78 Stat. 252, 42 US.C. §§ 2000d to 2000d-4) and the Regulations, hereby notifies all bidders that it will affirmatively ensure that any contract

entered into pursuant to this advertisement, disadvantaged business enterprises will be afforded full and fair opportunity to submit bids in response to this invitation and will not be discriminated against on the grounds of race, color, or national origin in consideration for an award. In accordance with other related nondiscrimination authorities, bidders and contractors will also not be discriminated against on the grounds of sex, age, disability, low-income level, creed/religion, or limited English proficiency in consideration for an award.”

4. Physically incorporate the FHWA-1273, in its entirety, into all subcontracts and subsequent lower tier subcontracts on Federal-aid highway construction contracts only.
 5. Provide language assistance services (i.e., written translation and oral interpretation), free of charge, to LEP employees and applicants. Contact NCDOT OCR for further assistance, if needed.
 6. For assistance with these Title VI requirements, contact the NCDOT Title VI Nondiscrimination Program at 1-800-522-0453.
- (b) Subrecipients (e.g. cities, counties, LGAs, planning organizations) may be required to prepare and submit a Title VI Plan to NCDOT, including Title VI Assurances and/or agreements. Subrecipients must also ensure compliance by their contractors and subrecipients with Title VI. (23 CFR 200.9(b)(7))
- (c) If reviewed or investigated by NCDOT, the contractor or subrecipient agrees to take affirmative action to correct any deficiencies found within a reasonable time period, not to exceed 90 calendar days, unless additional time is granted by NCDOT. (23 CFR 200.9(b)(15))
- (d) The Contractor is responsible for notifying subcontractors of NCDOT’s External Discrimination Complaints Process.
1. Applicability
Title VI and related laws protect participants and beneficiaries (e.g., members of the public and contractors) from discrimination by NCDOT employees, subrecipients and contractors, regardless of funding source.
 2. Eligibility
Any person—or class of persons—who believes he/she has been subjected to discrimination based on race, color, national origin, Limited English Proficiency (LEP), sex, age, or disability (and religion in the context of employment, aviation, or transit) may file a written complaint. The law also prohibits intimidation or retaliation of any sort.
 3. Time Limits and Filing Options
Complaints may be filed by the affected individual(s) or a representative and must be filed no later than 180 calendar days after the following:
 - (i) The date of the alleged act of discrimination; or
 - (ii) The date when the person(s) became aware of the alleged discrimination; or
 - (iii) Where there has been a continuing course of conduct, the date on which that conduct was discontinued or the latest instance of the conduct.Title VI and related discrimination complaints may be submitted to the following entities:
 - North Carolina Department of Transportation, Office of Civil Rights, Title VI Program, 1511 Mail Service Center, Raleigh, NC 27699-1511; toll free 1-800-522-0453
 - Federal Highway Administration, North Carolina Division Office, 310 New Bern Avenue, Suite 410, Raleigh, NC 27601, 919-747-7010

- US Department of Transportation, Departmental Office of Civil Rights, External Civil Rights Programs Division, 1200 New Jersey Avenue, SE, Washington, DC 20590; 202-366-4070
4. Format for Complaints
Complaints must be in writing and signed by the complainant(s) or a representative, and include the complainant's name, address, and telephone number. Complaints received by fax or e-mail will be acknowledged and processed. Allegations received by telephone will be reduced to writing and provided to the complainant for confirmation or revision before processing. Complaints will be accepted in other languages, including Braille.
 5. Discrimination Complaint Form
Contact NCDOT Civil Rights to receive a full copy of the Discrimination Complaint Form and procedures.
 6. Complaint Basis
Allegations must be based on issues involving race, color, national origin (LEP), sex, age, disability, or religion (in the context of employment, aviation or transit). "Basis" refers to the complainant's membership in a protected group category.

**TABLE 103-1
COMPLAINT BASIS**

Protected Categories	Definition	Examples	Applicable Nondiscrimination Authorities
Race and Ethnicity	An individual belonging to one of the accepted racial groups; or the perception, based usually on physical characteristics that a person is a member of a racial group	Black/African American, Hispanic/Latino, Asian, American Indian/Alaska Native, Native Hawaiian/Pacific Islander, White	Title VI of the Civil Rights Act of 1964; 49 CFR Part 21; 23 CFR 200; 49 U.S.C. 5332(b); 49 U.S.C. 47123. <i>(Executive Order 13166)</i>
Color	Color of skin, including shade of skin within a racial group	Black, White, brown, yellow, etc.	
National Origin (<i>Limited English Proficiency</i>)	Place of birth. Citizenship is not a factor. (<i>Discrimination based on language or a person's accent is also covered</i>)	Mexican, Cuban, Japanese, Vietnamese, Chinese	
Sex	Gender. The sex of an individual. <i>Note: Sex under this program does not include sexual orientation.</i>	Women and Men	1973 Federal-Aid Highway Act; 49 U.S.C. 5332(b); 49 U.S.C. 47123.
Age	Persons of any age	21-year-old person	Age Discrimination Act of 1975 49 U.S.C. 5332(b); 49 U.S.C. 47123.
Disability	Physical or mental impairment, permanent or temporary, or perceived.	Blind, alcoholic, para-amputee, epileptic, diabetic, arthritic	Section 504 of the Rehabilitation Act of 1973; Americans with Disabilities Act of 1990

<p>Religion (in the context of employment) <i>(Religion/ Creed in all aspects of any aviation or transit-related construction)</i></p>	<p>An individual belonging to a religious group; or the perception, based on distinguishable characteristics that a person is a member of a religious group. In practice, actions taken as a result of the moral and ethical beliefs as to what is right and wrong, which are sincerely held with the strength of traditional religious views. Note: Does not have to be associated with a recognized religious group or church; if an individual sincerely holds to the belief, it is a protected religious practice.</p>	<p>Muslim, Christian, Sikh, Hindu, etc.</p>	<p>Title VII of the Civil Rights Act of 1964; 23 CFR 230; FHWA-1273 Required Contract Provisions. <i>(49 U.S.C. 5332(b); 49 U.S.C. 47123)</i></p>
--	---	---	---

(3) Pertinent Nondiscrimination Authorities

During the performance of this contract, the contractor, for itself, its assignees, and successors in interest agrees to comply with the following non-discrimination statutes and authorities, including, but not limited to:

- (a) Title VI of the Civil Rights Act of 1964 (42 U.S.C. § 2000d et seq., 78 stat. 252), (prohibits discrimination on the basis of race, color, national origin); and 49 CFR Part 21.
- (b) The Uniform Relocation Assistance and Real Property Acquisition Policies Act of 1970, (42 U.S.C. § 4601), (prohibits unfair treatment of persons displaced or whose property has been acquired because of Federal or Federal-aid programs and projects);
- (c) Federal-Aid Highway Act of 1973, (23 U.S.C. § 324 et seq.), (prohibits discrimination on the basis of sex);
- (d) Section 504 of the Rehabilitation Act of 1973, (29 U.S.C. § 794 et seq.), as amended, (prohibits discrimination on the basis of disability) and 49 CFR Part 27;
- (e) The Age Discrimination Act of 1975, as amended, (42 U.S.C. § 6101 et seq.), (prohibits discrimination on the basis of age);
- (f) Airport and Airway Improvement Act of 1982, (49 USC § 471, Section 47123), as amended, (prohibits discrimination based on race, creed, color, national origin, or sex);
- (g) The Civil Rights Restoration Act of 1987, (PL 100-209), (Broadened the scope, coverage and applicability of Title VI of the Civil Rights Act of 1964, The Age Discrimination Act of 1975 and Section 504 of the Rehabilitation Act of 1973, by expanding the definition of the terms "programs or activities" to include all of the programs or activities of the Federal-aid recipients, sub-recipients and contractors, whether such programs or activities are Federally funded or not);
- (h) Titles II and III of the Americans with Disabilities Act, which prohibit discrimination on the basis of disability in the operation of public entities, public and private transportation systems, places of public accommodation, and certain testing entities (42 U.S.C. §§ 12131-12189) as implemented by Department of Transportation regulations at 49 C.F.R. parts 37 and 38;
- (i) The Federal Aviation Administration's Nondiscrimination statute (49 U.S.C. § 47123) (prohibits discrimination on the basis of race, color, national origin, and sex);
- (j) Executive Order 12898, Federal Actions to Address Environmental Justice in Minority Populations and Low-Income Populations, which ensures Nondiscrimination against minority populations by discouraging programs, policies, and activities with

disproportionately high and adverse human health or environmental effects on minority and low-income populations;

- (k) Executive Order 13166, Improving Access to Services for Persons with Limited English Proficiency, and resulting agency guidance, national origin discrimination includes discrimination because of Limited English proficiency (LEP). To ensure compliance with Title VI, you must take reasonable steps to ensure that LEP persons have meaningful access to your programs (70 Fed. Reg. at 74087 to 74100);
 - (l) Title IX of the Education Amendments of 1972, as amended, which prohibits you from discriminating because of sex in education programs or activities (20 U.S.C. 1681 et seq).
 - (m) Title VII of the Civil Rights Act of 1964 (42 U.S.C. § 2000e et seq., Pub. L. 88-352), (prohibits employment discrimination on the basis of race, color, religion, sex, or national origin).
- (4) **Additional Title VI Assurances**

***The following Title VI Assurances (Appendices B, C and D) shall apply, as applicable*

- (a) Clauses for Deeds Transferring United States Property (1050.2A, Appendix B)
The following clauses will be included in deeds effecting or recording the transfer of real property, structures, or improvements thereon, or granting interest therein from the United States pursuant to the provisions of Assurance 4.

NOW, THEREFORE, the U.S. Department of Transportation as authorized by law and upon the condition that the North Carolina Department of Transportation (NCDOT) will accept title to the lands and maintain the project constructed thereon in accordance with the North Carolina General Assembly, the Regulations for the Administration of the Federal-Aid Highway Program, and the policies and procedures prescribed by the Federal Highway Administration of the U.S. Department of Transportation in accordance and in compliance with all requirements imposed by Title 49, Code of Federal Regulations, U.S. Department of Transportation, Subtitle A, Office of the Secretary, Part 21, Nondiscrimination in Federally-assisted programs of the U.S. Department of Transportation pertaining to and effectuating the provisions of Title VI of the Civil Rights Act of 1964 (78 Stat. 252; 42 U.S.C. § 2000d to 2000d-4), does hereby remise, release, quitclaim and convey unto the NCDOT all the right, title and interest of the U.S. Department of Transportation in and to said lands described in Exhibit A attached hereto and made a part hereof.

(HABENDUM CLAUSE)

TO HAVE AND TO HOLD said lands and interests therein unto the North Carolina Department of Transportation (NCDOT) and its successors forever, subject, however, to the covenants, conditions, restrictions and reservations herein contained as follows, which will remain in effect for the period during which the real property or structures are used for a purpose for which Federal financial assistance is extended or for another purpose involving the provision of similar services or benefits and will be binding on the NCDOT, its successors and assigns.

The NCDOT, in consideration of the conveyance of said lands and interests in lands, does hereby covenant and agree as a covenant running with the land for itself, its successors and assigns, that (1) no person will on the grounds of race, color, or national origin, be excluded from participation in, be denied the benefits of, or be otherwise subjected to discrimination with regard to any facility located wholly or in part on, over, or under such lands hereby conveyed [,] [and]* (2) that the NCDOT will use the lands and interests in lands and interests in lands so conveyed, in compliance with all requirements imposed by or pursuant to Title 49, Code of Federal Regulations, U.S. Department of Transportation, Subtitle A, Office of the Secretary, Part 21, Non-discrimination in Federally-assisted programs of the U.S. Department of Transportation, Effectuation of Title VI of the Civil Rights Act of 1964, and as said Regulations and Acts may be amended [, and (3) that in the event of breach of any of the above-mentioned nondiscrimination conditions, the Department will have a right to enter or re-enter said lands and facilities on said land, and that above described land and facilities will thereon revert to and vest in and become the absolute property of the U.S. Department of Transportation and its assigns as such interest existed prior to this instruction].*

(*Reverter clause and related language to be used only when it is determined that such a clause is necessary in order to make clear the purpose of Title VI.)

(b) Clauses for Transfer of Real Property Acquired or Improved Under the Activity, Facility, or Program (1050.2A, Appendix C)

The following clauses will be included in deeds, licenses, leases, permits, or similar instruments entered into by the North Carolina Department of Transportation (NCDOT) pursuant to the provisions of Assurance 7(a):

1. The (grantee, lessee, permittee, etc. as appropriate) for himself/herself, his/her heirs, personal representatives, successors in interest, and assigns, as a part of the consideration hereof, does hereby covenant and agree [in the case of deeds and leases add "as a covenant running with the land"] that:
 - (i.) In the event facilities are constructed, maintained, or otherwise operated on the property described in this (deed, license, lease, permit, etc.) for a purpose for which a U.S. Department of Transportation activity, facility, or program is extended or for another purpose involving the provision of similar services or benefits, the (grantee, licensee, lessee, permittee, etc.) will maintain and operate such facilities and services in compliance with all requirements imposed by the Acts and Regulations (as may be amended) such that no person on the grounds of race, color, or national origin, will be excluded from participation in, denied the benefits of, or be otherwise subjected to discrimination in the use of said facilities.
2. With respect to licenses, leases, permits, etc., in the event of breach of any of the above Nondiscrimination covenants, the NCDOT will have the right to terminate the (lease, license, permit, etc.) and to enter, re-enter, and repossess said lands and facilities thereon, and hold the same as if the (lease, license, permit, etc.) had never been made or issued. *
3. With respect to a deed, in the event of breach of any of the above Nondiscrimination covenants, the NCDOT will have the right to enter or re-enter the lands and facilities thereon, and the above described lands and facilities will there upon revert to and vest in and become the absolute property of the NCDOT and its assigns. *

- (*Reverter clause and related language to be used only when it is determined that such a clause is necessary to make clear the purpose of Title VI.)
- (c) Clauses for Construction/Use/Access to Real Property Acquired Under the Activity, Facility or Program (1050.2A, Appendix D)

The following clauses will be included in deeds, licenses, permits, or similar instruments/ agreements entered into by the North Carolina Department of Transportation (NCDOT) pursuant to the provisions of Assurance 7(b):

1. The (grantee, licensee, permittee, etc., as appropriate) for himself/herself, his/her heirs, personal representatives, successors in interest, and assigns, as a part of the consideration hereof, does hereby covenant and agree (in the case of deeds and leases add, "as a covenant running with the land") that (1) no person on the ground of race, color, or national origin, will be excluded from participation in, denied the benefits of, or be otherwise subjected to discrimination in the use of said facilities, (2) that in the construction of any improvements on, over, or under such land, and the furnishing of services thereon, no person on the ground of race, color, or national origin, will be excluded from participation in, denied the benefits of, or otherwise be subjected to discrimination, (3) that the (grantee, licensee, lessee, permittee, etc.) will use the premises in compliance with all other requirements imposed by or pursuant to the Acts and Regulations, as amended, set forth in this Assurance.
2. With respect to (licenses, leases, permits, etc.), in the event of breach of any of the above Non-discrimination covenants, the NCDOT will have the right to terminate the (license, permit, etc., as appropriate) and to enter or re-enter and repossess said land and the facilities thereon, and hold the same as if said (license, permit, etc., as appropriate) had never been made or issued. *
3. With respect to deeds, in the event of breach of any of the above Nondiscrimination covenants, the NCDOT will there upon revert to and vest in and become the absolute property of the NCDOT and its assigns. *

(*Reverter clause and related language to be used only when it is determined that such a clause is necessary to make clear the purpose of Title VI.)

STANDARD SPECIAL PROVISION**ON-THE-JOB TRAINING**

(10-16-07) (Rev. 4-21-15)

Z-10

Description

The North Carolina Department of Transportation will administer a custom version of the Federal On-the-Job Training (OJT) Program, commonly referred to as the Alternate OJT Program. All contractors (existing and newcomers) will be automatically placed in the Alternate Program. Standard OJT requirements typically associated with individual projects will no longer be applied at the project level. Instead, these requirements will be applicable on an annual basis for each contractor administered by the OJT Program Manager.

On the Job Training shall meet the requirements of 23 CFR 230.107 (b), 23 USC – Section 140, this provision and the On-the-Job Training Program Manual.

The Alternate OJT Program will allow a contractor to train employees on Federal, State and privately funded projects located in North Carolina. However, priority shall be given to training employees on NCDOT Federal-Aid funded projects.

Minorities and Women

Developing, training and upgrading of minorities and women toward journeyman level status is a primary objective of this special training provision. Accordingly, the Contractor shall make every effort to enroll minority and women as trainees to the extent that such persons are available within a reasonable area of recruitment. This training commitment is not intended, and shall not be used, to discriminate against any applicant for training, whether a member of a minority group or not.

Assigning Training Goals

The Department, through the OJT Program Manager, will assign training goals for a calendar year based on the contractors' past three years' activity and the contractors' anticipated upcoming year's activity with the Department. At the beginning of each year, all contractors eligible will be contacted by the Department to determine the number of trainees that will be assigned for the upcoming calendar year. At that time the Contractor shall enter into an agreement with the Department to provide a self-imposed on-the-job training program for the calendar year. This agreement will include a specific number of annual training goals agreed to by both parties. The number of training assignments may range from 1 to 15 per contractor per calendar year. The Contractor shall sign an agreement to fulfill their annual goal for the year.\

Training Classifications

The Contractor shall provide on-the-job training aimed at developing full journeyman level workers in the construction craft/operator positions. Preference shall be given to providing training in the following skilled work classifications:

Equipment Operators	Office Engineers
Truck Drivers	Estimators
Carpenters	Iron / Reinforcing Steel Workers
Concrete Finishers	Mechanics
Pipe Layers	Welders

The Department has established common training classifications and their respective training requirements that may be used by the contractors. However, the classifications established are not all-inclusive. Where the training is oriented toward construction applications, training will be allowed in lower-level management positions such as office engineers and estimators. Contractors shall submit new classifications for specific job functions that their employees are performing. The Department will review and recommend for acceptance to FHWA the new classifications proposed by contractors, if applicable. New classifications shall meet the following requirements:

Proposed training classifications are reasonable and realistic based on the job skill classification needs, and

The number of training hours specified in the training classification is consistent with common practices and provides enough time for the trainee to obtain journeyman level status.

The Contractor may allow trainees to be trained by a subcontractor provided that the Contractor retains primary responsibility for meeting the training and this provision is made applicable to the subcontract. However, only the Contractor will receive credit towards the annual goal for the trainee.

Where feasible, 25 percent of apprentices or trainees in each occupation shall be in their first year of apprenticeship or training. The number of trainees shall be distributed among the work classifications on the basis of the contractor's needs and the availability of journeymen in the various classifications within a reasonable area of recruitment.

No employee shall be employed as a trainee in any classification in which they have successfully completed a training course leading to journeyman level status or in which they have been employed as a journeyman.

Records and Reports

The Contractor shall maintain enrollment, monthly and completion reports documenting company compliance under these contract documents. These documents and any other information as requested shall be submitted to the OJT Program Manager.

Upon completion and graduation of the program, the Contractor shall provide each trainee with a certification Certificate showing the type and length of training satisfactorily completed.

Trainee Interviews

All trainees enrolled in the program will receive an initial and Trainee/Post graduate interview conducted by the OJT program staff.

Trainee Wages

Contractors shall compensate trainees on a graduating pay scale based upon a percentage of the prevailing minimum journeyman wages (Davis-Bacon Act). Minimum pay shall be as follows:

60 percent	of the journeyman wage for the first half of the training period
75 percent	of the journeyman wage for the third quarter of the training period
90 percent	of the journeyman wage for the last quarter of the training period

In no instance shall a trainee be paid less than the local minimum wage. The Contractor shall adhere to the minimum hourly wage rate that will satisfy both the NC Department of Labor (NCDOL) and the Department.

Achieving or Failing to Meet Training Goals

The Contractor will be credited for each trainee employed by him on the contract work who is currently enrolled or becomes enrolled in an approved program and who receives training for at least 50 percent of the specific program requirement. Trainees will be allowed to be transferred between projects if required by the Contractor's scheduled workload to meet training goals.

If a contractor fails to attain their training assignments for the calendar year, they may be taken off the NCDOT's Bidders List.

Measurement and Payment

No compensation will be made for providing required training in accordance with these contract documents.

Geotechnical Provisions

STANDARD SHORING (10/19/2021)		GT-1.1	GT-1.4
Shiping Yang	WRO_HFO		
TEMPORARY SOIL NAIL WALLS (10/19/2021)		GT-2.1	GT-2.9
Shiping Yang	WRO_HFO		
AGGREGATE SUBGRADE (SPECIAL)		GT-3.1	GT-3.1
John Pilipchuk	GEU Head		
SOLDIER PILE RETAINING WALLS (LRFD) (10/19/2021)		GT-4.1	GT-4.8
Greg Bodenheimer	Contracts		
MECHANICALLY STABILIZED EARTH RETAINING WALLS - (10/19/2021)		GT-5.1	GT-5.12
Greg Bodenheimer	Contracts		
NATURAL STONE VENEER (SPECIAL)		GT-6.1	GT-6.4
Shane Clark	WRO_AFO		

DocuSigned by:

 48805AD5014A4B0...

07/13/2023

STANDARD SHORING:**(10-19-21)****Description**

Standard shoring includes standard temporary shoring and standard temporary mechanically stabilized earth (MSE) walls. At the Contractor's option, use standard shoring as noted in the plans or as directed. When using standard shoring, a temporary shoring design submittal is not required. Construct standard shoring based on actual elevations and shoring dimensions in accordance with the contract and Geotechnical Standard Detail No. 1801.01 or 1801.02.

Define "standard temporary shoring" as cantilever shoring that meets the standard temporary shoring detail (Geotechnical Standard Detail No. 1801.01). Define "standard temporary wall" as a temporary MSE wall with geotextile or geogrid reinforcement that meets the standard temporary wall detail (Geotechnical Standard Detail No. 1801.02). Define "standard temporary geotextile wall" as a standard temporary wall with geotextile reinforcement and "standard temporary geogrid wall" as a standard temporary wall with geogrid reinforcement.

Provide positive protection for standard shoring at locations shown in the plans and as directed. See *Temporary Shoring* provision for positive protection types and definitions.

Materials

Refer to the *Standard Specifications*.

Item	Section
Concrete Barrier Materials	1170-2
Flowable Fill, Excavatable	1000-6
Geosynthetics	1056
Grout, Type 1	1003
Portland Cement Concrete, Class A	1000
Select Materials	1016
Steel Beam Guardrail Materials	862-2
Steel Sheet Piles and H-Piles	1084
Untreated Timber	1082-2
Welded Wire Reinforcement	1070-3

Provide Type 6 material certifications for shoring materials. Use Class IV select material for temporary guardrail. Use Class A concrete that meets Article 450-2 of the *Standard Specifications* or Type 1 grout for drilled-in piles.

Based on actual shoring height, positive protection, groundwater elevation, slope or surcharge case and traffic impact at each standard temporary shoring location, use sheet piles with the minimum required section modulus or H-piles with the sizes shown in Geotechnical Standard Detail No. 1801.01. Use untreated timber with a thickness of at least 3" and a bending stress of at least 1,000 psi for timber lagging.

(A) Shoring Backfill

Use Class II, Type 1, Class III, Class V or Class VI select material or material that meets AASHTO M 145 for soil classification A-2-4 with a maximum PI of 6 for shoring backfill except do not use the following:

- (1) A-2-4 soil for backfill around culverts,

- (2) A-2-4 soil in the reinforced zone of standard temporary walls with a back slope and
- (3) Class VI select material in the reinforced zone of standard temporary geotextile walls.

(B) Standard Temporary Walls

Use welded wire reinforcement for welded wire facing, struts and wires with the dimensions and minimum wire sizes shown in Geotechnical Standard Detail No. 1801.02. Provide Type 2 geotextile for separation and retention geotextiles. Do not use more than 4 different reinforcement strengths for each standard temporary wall.

(1) Geotextile Reinforcement

Provide Type 5 geotextile for geotextile reinforcement with a mass per unit area of at least 8 oz/sy in accordance with ASTM D5261. Based on actual wall height, groundwater elevation, slope or surcharge case and shoring backfill to be used in the reinforced zone at each standard temporary geotextile wall location, provide geotextiles with ultimate tensile strengths as shown in Geotechnical Standard Detail No. 1801.02.

(2) Geogrid Reinforcement

Use geogrids for geogrid reinforcement with a roll width of at least 4 ft and an “approved” status code in accordance with the NCDOT Geosynthetic Reinforcement Evaluation Program. The list of approved geogrids is available from:

connect.ncdot.gov/resources/Geological/Pages/Products.aspx

Based on actual wall height, groundwater or flood elevation, slope or surcharge case and shoring backfill to be used in the reinforced zone at each standard temporary geogrid wall location, provide geogrids for geogrid reinforcement with short-term design strengths as shown in Geotechnical Standard Detail No. 1801.02. Geogrids are approved for short-term design strengths (3-year design life) in the machine direction (MD) and cross-machine direction (CD) based on material type. Define material type from the website above for shoring backfill as follows:

Material Type	Shoring Backfill
Borrow	A-2-4 Soil
Fine Aggregate	Class II, Type 1 or Class III Select Material
Coarse Aggregate	Class V or VI Select Material

Preconstruction Requirements

(A) Concrete Barrier

Define “clear distance” behind concrete barrier as the horizontal distance between the barrier and edge of pavement. The minimum required clear distance for concrete barrier is shown in the plans. At the Contractor’s option or if the minimum required clear distance is not available, set concrete barrier next to and up against traffic side of standard shoring except for barrier above standard temporary walls. Concrete barrier with the minimum required clear distance is required above standard temporary walls.

(B) Temporary Guardrail

Define “clear distance” behind temporary guardrail as the horizontal distance between guardrail posts and standard shoring. At the Contractor’s option or if clear distance for standard temporary shoring is less than 4 ft, attach guardrail to traffic side of shoring as shown in the plans. Place ABC in clear distance and around guardrail posts instead of pavement. Do not use temporary guardrail above standard temporary walls.

(C) Standard Shoring Selection Forms

Before beginning standard shoring construction, survey existing ground elevations in the vicinity of standard shoring locations to determine actual shoring or wall heights (H). Submit a standard shoring selection form for each location at least 7 days before starting standard shoring construction. Standard shoring selection forms are available from:

connect.ncdot.gov/resources/Geological/Pages/Geotech_Forms_Details.aspx

Construction Methods

Construct standard shoring in accordance with the *Temporary Shoring* provision.

(A) Standard Temporary Shoring Installation

Based on actual shoring height, positive protection, groundwater elevation, slope or surcharge case and traffic impact at each standard temporary shoring location, install piles with the minimum required embedment and extension for each shoring section in accordance with Geotechnical Standard Detail No. 1801.01. For concrete barrier above and next to standard temporary shoring and temporary guardrail above and attached to standard temporary shoring, use “surcharge case with traffic impact” in accordance with Geotechnical Standard Detail No. 1801.01. Otherwise, use “slope or surcharge case with no traffic impact” in accordance with Geotechnical Standard Detail No. 1801.01. If refusal is reached before driven piles attain the minimum required embedment, use drilled-in H-piles with timber lagging for standard temporary shoring.

(B) Standard Temporary Walls Installation

Based on actual wall height, groundwater elevation, slope or surcharge case, geotextile or geogrid reinforcement and shoring backfill in the reinforced zone at each standard temporary wall location, construct walls with the minimum required reinforcement length and number of reinforcement layers for each wall section in accordance with Geotechnical Standard Detail No. 1801.02. For standard temporary walls with pile foundations in the reinforced zone, drive piles through reinforcement after constructing temporary walls.

For standard temporary walls with interior angles less than 90°, wrap geosynthetics at acute corners as directed by the Engineer. Place geosynthetics as shown in Geotechnical Standard Detail No. 1801.02. Place separation geotextiles between shoring backfill and backfill, natural ground or culverts along the sides of the reinforced zone perpendicular to the wall face. For Class V or VI select material in the reinforced zone, place separation geotextiles between shoring backfill and backfill or natural ground on top of and at the back of the reinforced zone.

Measurement and Payment

Standard shoring will be measured and paid in accordance with the *Temporary Shoring* provision.

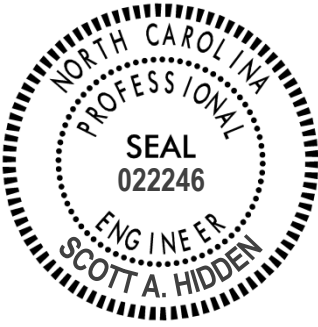

DocuSigned by:
Scott A. Hidden
F760CAEB96FC4D3...
06/14/2023

TEMPORARY SOIL NAIL WALLS:**(10-19-21)****Description**

Construct temporary soil nail walls consisting of soil nails spaced at a regular pattern and connected to a reinforced shotcrete face. A soil nail consists of a solid or hollow steel bar grouted in a drilled hole inclined at an angle below horizontal. At the Contractor's option, use temporary soil nail walls instead of temporary shoring for full cut sections. Design and construct temporary soil nail walls based on actual elevations and wall dimensions in accordance with the contract and accepted submittals. Use a prequalified Anchored Wall Contractor to construct temporary soil nail walls. Define "soil nail wall" as a temporary soil nail wall and "Soil Nail Wall Contractor" as the Anchored Wall Contractor installing soil nails and applying shotcrete. Define "nail" as a soil nail.

Provide positive protection for soil nail walls at locations shown in the plans and as directed. See *Temporary Shoring* provision for positive protection types and definitions.

Materials

Refer to Division 10 of the *Standard Specifications*.

Item	Section
Geocomposites	1056
Portland Cement	1024-1
Reinforcing Steel	1070
Shotcrete	1002
Select Material, Class IV	1016
Steel Plates	1072-2
Water	1024-4

Use neat cement grout that only contains cement and water with a water cement ratio of 0.4 to 0.5 which is approximately 5.5 gallons of water per 94 lb of Portland cement. Provide grout with a compressive strength at 3 and 28 days of at least 1,500 psi and 4,000 psi, respectively.

Use Class IV select material for temporary guardrail. Provide soil nails consisting of grouted steel bars and nail head assemblies. Use deformed solid steel bars that meet AASHTO M 275 or M 31, Grade 60, 75 or 80. Splice solid bars in accordance with Article 1070-9 of the *Standard Specifications*. Use hollow steel bars manufactured by DYWIDAG-Systems International USA Inc., Nucor Skyline, Williams Form Engineering Corp. or an approved equal.

Use centralizers that meet Article 34.3.4 of the *AASHTO LRFD Bridge Construction Specifications*. Provide nail head assemblies consisting of nuts, washers and bearing plates. Use steel plates for bearing plates and steel washers and hex nuts recommended by the Soil Nail Manufacturer.

Provide Type 6 material certifications for soil nail materials in accordance with Article 106-3 of the *Standard Specifications*. Store steel materials on blocking at least 12" above the ground and protect it at all times from damage; and when placing in the work make sure it is free from dirt, dust, loose mill scale, loose rust, paint, oil or other foreign materials. Load, transport, unload and store soil nail wall materials so materials are kept clean and free of damage. Bent, damaged or defective materials will be rejected.

Preconstruction Requirements

(A) Concrete Barrier

Define “clear distance” behind concrete barrier as the horizontal distance between the barrier and edge of pavement. The minimum required clear distance for concrete barrier is shown in the plans. At the Contractor’s option or if the minimum required clear distance is not available, set concrete barrier next to and up against traffic side of soil nail walls except for barrier above walls. Concrete barrier with the minimum required clear distance is required above soil nail walls.

(B) Temporary Guardrail

Define “clear distance” behind temporary guardrail as the horizontal distance between guardrail posts and soil nail walls. At the Contractor’s option or if clear distance for soil nail walls is less than 4 ft, use temporary guardrail with 8 ft posts and a clear distance of at least 2.5 ft. Place ABC in clear distance and around guardrail posts instead of pavement.

(C) Soil Nail Wall Designs

Before beginning soil nail wall design, survey existing ground elevations in the vicinity of wall locations to determine actual design heights (H). Use a prequalified Anchored Wall Design Consultant to design soil nail walls. Provide designs sealed by a Design Engineer approved as a Geotechnical Engineer (key person) for the Anchored Wall Design Consultant.

Design soil nail walls in accordance with the plans and the *AASHTO LRFD Bridge Design Specifications* unless otherwise required. Design soil nails that meet the following unless otherwise approved:

- (1) Horizontal and vertical spacing of at least 3 ft,
- (2) Inclination of at least 12° below horizontal and
- (3) Diameter of 4" to 10".

Do not extend nails beyond right-of-way or easement limits. If existing or future obstructions such as foundations, pavements, pipes, inlets or utilities will interfere with nails, maintain a clearance of at least 6" between obstructions and nails.

Design soil nail walls for a traffic surcharge of 250 psf if traffic will be above and within H of walls. This traffic surcharge does not apply to construction traffic. Design soil nail walls for any construction surcharge if construction traffic will be above and within H of walls. For temporary guardrail with 8 ft posts above soil nail walls, analyze shotcrete and top row of nails for a nominal horizontal load of 300 lb/ft of wall with a load factor of 1.0.

Place geocomposite sheet drains with a horizontal spacing of no more than 10 ft and center drains between adjacent nails. Attach sheet drains to excavation faces. Design shotcrete in accordance with Article 11.12.6.2 of the *AASHTO LRFD Bridge Design Specifications*.

Submit PDF files of working drawings and design calculations for soil nail wall designs in accordance with Article 105-2 of the *Standard Specifications*. Submit working drawings showing plan views, wall profiles, typical sections and details of soil nail wall

design and construction sequence. Include details in working drawings of soil nail locations, unit grout/ground bond strengths, shotcrete reinforcement and if necessary, obstructions extending through walls or interfering with nails. Include details in construction sequence of excavation, grouting, installing reinforcement, nail testing and shotcreting with mix designs and shotcrete nozzleman certifications. Do not begin soil nail wall construction until a design submittal is accepted.

Submit design calculations for each wall section with different surcharge loads, geometry or material parameters. Include analysis of temporary conditions during construction in design calculations. At least one analysis is required for each wall section with different nail lengths. Analyze internal and compound stability with a computer software program that uses limit equilibrium methods and submit all PDF output files from the program with the design calculations. See Article C11.12.2 of the AASHTO LRFD specifications for determining the maximum soil nail force, $T_{\max sn}$. Once $T_{\max sn}$ and pullout length behind slip surface, L_P , are determined from limit equilibrium methods at the target soil failure resistance factor (1 over factor of safety output from computer software), use these values for soil nail (pullout and tensile resistance) and wall facing (flexure, punching shear and headed-stud tensile resistance) design in accordance with Articles 11.12.5.2, 11.12.6.1 and 11.12.6.2 of the AASHTO LRFD specifications.

- (1) When designing soil nail walls with computer software Snail manufactured by the California Department of Transportation (CALTRANS), use Snail version 2.2.0 or later, to calculate factors of safety and $T_{\max sn}$ and L_P values in accordance with the following: Allowable Stress Design for Analysis Method with no load factors applied except those applied to factored surcharge loads from structures or traffic,
- (2) Perform Below Toe Search option selected when any soil layer has a friction angle less than 30° and
- (3) Default value of 0.33 for Interface Friction Reduction Factor.

When designing soil nail walls with computer software other than Snail, use bi-linear (or tri-linear, as applicable) search surfaces intended to reproduce Snail results. Factors of safety and $T_{\max sn}$ and L_P values are acceptable if they are within 5% of the factors of safety and $T_{\max sn}$ and L_P values calculated by the Engineer using the computer software Slide2 manufactured by Rocscience, Inc.

(D) Preconstruction Meeting

Before starting soil nail wall construction, hold a preconstruction meeting to discuss the construction, inspection and testing of the soil nail walls. If this meeting occurs before all soil nail wall submittals have been accepted, additional preconstruction meetings may be required before beginning construction of soil nail walls without accepted submittals. The Resident, District or Bridge Maintenance Engineer, Area Construction Engineer, Geotechnical Operations Engineer, Contractor and Soil Nail Wall Contractor Superintendent will attend preconstruction meetings.

Construction Methods

Control drainage during construction in the vicinity of soil nail walls. Direct run off away from soil nail walls and areas above and behind walls.

Install foundations located behind soil nail walls before beginning wall construction. Do not excavate behind soil nail walls. If overexcavation occurs, repair walls with an approved method and a revised soil nail wall design may be required.

Install positive protection in accordance with the contract and accepted submittals. Use PCB in accordance with Section 1170 of the *Standard Specifications* and Roadway Standard Drawing No. 1170.01. Use temporary guardrail in accordance with Section 862 of the *Standard Specifications* and Roadway Standard Drawing No. 862.01, 862.02 and 862.03.

(A) Excavation

Excavate for soil nail walls from the top down in accordance with the accepted submittals. Excavate in staged horizontal lifts with no negative batter (excavation face leaning forward). Excavate lifts in accordance with the following:

- (1) Heights not to exceed vertical nail spacing,
- (2) Bottom of lifts no more than 3 ft below nail locations for current lift and
- (3) Horizontal and vertical alignment within 6" of location shown in the accepted submittals.

Remove any cobbles, boulders, rubble or debris that will protrude more than 2" into the required shotcrete thickness. Rocky ground such as colluvium, boulder fills and weathered rock may be difficult to excavate without leaving voids.

Apply shotcrete to excavation faces within 24 hours of excavating each lift unless otherwise approved. Shotcreting may be delayed if it can be demonstrated that delays will not adversely affect excavation stability. If excavation faces will be exposed for more than 24 hours, use polyethylene sheets anchored at top and bottom of lifts to protect excavation faces from changes in moisture content.

If an excavation becomes unstable at any time, suspend soil nail wall construction and temporarily stabilize the excavation by immediately placing an earth berm up against the unstable excavation face. When this occurs, repair walls with an approved method and a revised soil nail wall design may be required.

Do not excavate the next lift until nail installations and testing and shotcrete application for the current lift are accepted and grout and shotcrete for the current lift have cured at least 3 days and 1 day, respectively.

(B) Soil Nails

Drill and grout nails the same day and do not leave drill holes open overnight. Control drilling and grouting to prevent excessive ground movements, damaging structures and pavements or fracturing rock and soil formations. If ground heave or subsidence occurs, suspend soil nail wall construction and take corrective action to minimize movement. If property damage occurs, make repairs with an approved method and a revised soil nail wall design may be required.

The drilling, steel bar and grouting requirements below are for solid bar nails and may not apply to hollow bar nails. Hollow bar nails are typically installed by simultaneously drilling and grouting as a sacrificial drill bit is advanced and grout is pumped through the bar. For hollow bar nails, submit drilling and grouting procedures for approval before

installing soil nails.

(1) Drilling

Use drill rigs of the sizes necessary to install soil nails and with sufficient capacity to drill through whatever materials are encountered. Drill straight and clean holes with the dimensions and inclination shown in the accepted submittals. Drill holes within 6" of locations and 2° of inclination shown in the accepted submittals unless otherwise approved.

Stabilize drill holes with temporary casings if unstable, caving or sloughing material is anticipated or encountered. Do not use drilling fluids to stabilize drill holes or remove cuttings.

(2) Steel Bars

Center solid steel bars in drill holes with centralizers. Securely attach centralizers along bars at no more than 8 ft centers. Attach uppermost and lowermost centralizers 18" from excavation faces and ends of holes.

Do not insert solid steel bars into drill holes until hole locations, dimensions, inclination and cleanliness are approved. Do not vibrate, drive or otherwise force bars into holes. If a steel bar cannot be completely and easily inserted into a drill hole, remove the bar and clean or redrill the hole.

(3) Grouting

Mix and place grout in accordance with Subarticles 1003-5, 1003-6 and 1003-7 of the *Standard Specifications*. Remove oil, rust inhibitors, residual drilling fluids and similar foreign materials from holding tanks/hoppers, stirring devices, pumps, lines, tremie pipes and any other equipment in contact with grout before use. Measure grout temperature, density and flow during grouting with at least the same frequency grout cubes are made for compressive strength. Perform density and flow field tests in the presence of the Engineer in accordance with American National Standards Institute/American Petroleum Institute Recommended Practice 13B-1 (Section 4, Mud Balance) and ASTM C939 (Flow Cone), respectively.

Inject grout at the lowest point of drill holes through tremies, e.g., grout tubes, casings, hollow-stem augers or drill rods, in one continuous operation. Fill drill holes progressively from ends of holes to excavation faces and withdraw tremies at a slow even rate as holes are filled to prevent voids in grout. Extend tremies into grout at least 5 ft at all times except when grout is initially placed in holes.

Provide grout free of segregation, intrusions, contamination, structural damage or inadequate consolidation (honeycombing). Cold joints in grout are not allowed except for test nails. Remove any temporary casings as grout is placed and record grout volume for each drill hole.

(4) Nail Heads

Install nail head assemblies after shotcreting. Before shotcrete reaches initial set, seat bearing plates and tighten nuts so plates contact shotcrete uniformly. If uniform contact is not possible, install nail head assemblies on mortar pads so nail

heads are evenly loaded.

(C) Sheet Drains

Install geocomposite sheet drains as shown in the accepted submittals. Before installing shotcrete reinforcement, place sheet drains with the geotextile side against excavation faces. For highly irregular faces and at the discretion of the Engineer, sheet drains may be placed after shotcreting over weep holes through the shotcrete. Hold sheet drains in place with anchor pins so drains are in continuous contact with surfaces to which they are attached and allow for full flow the entire height of soil nail walls. Discontinuous sheet drains are not allowed. If splices are needed, overlap sheet drains at least 12" so flow is not impeded. Cut off excess sheet drain length and expose drain ends below shotcrete when soil nail wall construction is complete.

(D) Shotcrete

Clean ungrouted zones of drill holes and excavation faces of loose materials, mud, rebound and other foreign material. Moisten surfaces to receive shotcrete. Install shotcrete reinforcement in accordance with the contract and accepted submittals. Secure reinforcing steel so shooting does not displace or vibrate reinforcement. Install approved thickness gauges on 5 ft centers in the horizontal and vertical directions to measure shotcrete thickness.

Apply shotcrete in accordance with the contract, accepted submittals and Subarticle 1002-3(F) of the *Standard Specifications*. Use approved shotcrete nozzlemen who made satisfactory preconstruction test panels to apply shotcrete. Direct shotcrete at right angles to excavation faces except when shooting around reinforcing steel. Rotate nozzle steadily in small circular patterns and apply shotcrete from bottom of lifts up.

Make shotcrete surfaces uniform and free of sloughing or sagging. Completely fill ungrouted zones of drill holes and any other voids with shotcrete. Taper construction joints to a thin edge over a horizontal distance of at least the shotcrete thickness. Wet joint surfaces before shooting adjacent sections.

Repair surface defects as soon as possible after shooting. Remove any shotcrete which lacks uniformity, exhibits segregation, honeycombing or lamination or contains any voids or sand pockets and replace with fresh shotcrete to the satisfaction of the Engineer. Protect shotcrete from freezing and rain until shotcrete reaches initial set.

(E) Construction Records

Provide 2 copies of soil nail wall construction records within 24 hours of completing each lift. Include the following in construction records:

- (1) Names of Soil Nail Wall Contractor, Superintendent, Nozzleman, Drill Rig Operator, Project Manager and Design Engineer;
- (2) Wall description, county, Department's contract, TIP and WBS element number;
- (3) Wall station and number and lift location, dimensions, elevations and description;
- (4) Nail locations, dimensions and inclinations, bar types, sizes and grades and temporary casing information;

- (5) Date and time drilling begins and ends, steel bars are inserted into drill holes, grout and shotcrete are mixed and arrives on-site and grout placement and shotcrete application begins and ends;
- (6) Grout volume, temperature, flow and density records;
- (7) Ground and surface water conditions and elevations if applicable;
- (8) Weather conditions including air temperature at time of grout placement and shotcrete application; and
- (9) All other pertinent details related to soil nail wall construction.

After completing each soil nail wall or stage of a wall, provide a PDF file of all corresponding construction records.

Nail Testing

“Proof tests” are performed on nails incorporated into walls, i.e., production nails. Define “test nail” as a nail tested with a proof test. Proof tests are typically required for at least one nail per nail row per soil nail wall or at least 5% of production nails, whichever is greater. More or less test nails may be required depending on subsurface conditions encountered. The Engineer will determine the number and locations of proof tests required. Do not test nails until grout and shotcrete attain the required 3-day compressive strength.

(A) Test Equipment

Use the following equipment to test nails:

- (1) Two dial gauges with rigid supports,
- (2) Hydraulic jack and pressure gauge and
- (3) Jacking block or reaction frame.

Provide dial gauges with enough range and precision to measure the maximum test nail movement to 0.001". Use pressure gauges graduated in 100 psi increments or less. Submit identification numbers and calibration records for load cells, jacks and pressure gauges with the soil nail wall design. Calibrate each jack and pressure gauge as a unit.

Align test equipment to uniformly and evenly load test nails. Use a jacking block or reaction frame that does not damage or contact shotcrete within 3 ft of nail heads. Place dial gauges opposite each other on either side of test nails and align gauges within 5° of bar inclinations. Set up test equipment so resetting or repositioning equipment during nail testing is not needed.

(B) Test Nails

Test nails include both unbonded and bond lengths. Grout only bond lengths before nail testing. Provide unbonded and bond lengths of at least 3 ft and 10 ft, respectively.

Steel bars for production nails may be overstressed under higher test nail loads. If necessary, use larger size or higher grade bars with more capacity for test nails instead of shortening bond lengths to less than the minimum required.

(C) Proof Tests

Test proof test nails in accordance with the accepted submittals and Article 34.5.5.3, respectively of the *AASHTO LRFD Bridge Construction Specifications*.

(D) Test Nail Acceptance

Submit 2 copies of test nail records including load versus movement and time versus creep movement plots within 24 hours of completing each proof test. The Engineer will review the test nail records to determine if test nails are acceptable. Test nail acceptance is based in part on the acceptance criteria in Article 34.5.5.4 of the *AASHTO LRFD Bridge Construction Specifications*.

Maintain stability of unbonded lengths for subsequent grouting. If a test nail is accepted but the unbonded length cannot be satisfactorily grouted, do not incorporate the test nail into the soil nail wall and add another production nail to replace the test nail.

If the Engineer determines a test nail is unacceptable, either perform additional proof tests on adjacent production nails or revise the soil nail design or installation methods for the production nails represented by the unacceptable test nail as determined by the Engineer. Submit a revised soil nail wall design for acceptance, provide an acceptable test nail with the revised design or installation methods and install additional production nails for the nails represented by the unacceptable test nail.

After completing nail testing for each soil nail wall or stage of a wall, provide a PDF file of all corresponding test nail records.

Measurement and Payment

Temporary soil nail walls will be measured and paid in square feet. Temporary soil nail walls will be paid for at the contract unit price for *Temporary Shoring*. Temporary soil nail walls will be measured as the square feet of exposed wall face area. No measurement will be made for any embedment or pavement thickness above soil nail walls.

The contract unit price for *Temporary Shoring* will be full compensation for providing soil nail wall designs, submittals, labor, tools, equipment and soil nail wall materials, excavating, hauling and removing excavated materials, installing and testing soil nails, grouting, shotcreting and supplying sheet drains and any incidentals necessary to construct soil nail walls. No additional payment will be made and no extension of completion date or time will be allowed for repairing property damage, overexcavations or unstable excavations, unacceptable test nails or thicker shotcrete.

No payment will be made for temporary shoring not shown in the plans or required by the Engineer including shoring for OSHA reasons or the Contractor's convenience. No value engineering proposals will be accepted based solely on revising or eliminating shoring locations shown in the plans or estimated quantities shown in the bid item sheets as a result of actual field measurements or site conditions.

PCB will be measured and paid in accordance with Section 1170 of the *Standard Specifications*. No additional payment will be made for anchoring PCB for soil nail walls. Costs for anchoring PCB will be incidental to soil nail walls.

Temporary guardrail will be measured and paid for in accordance with Section 862 of the *Standard Specifications*.



DocuSigned by:
Scott A. Hidden
F760CAEB96FC4D3...
06/14/2023

AGGREGATE SUBGRADE**(SPECIAL)**Revise the *2018 Standard Specifications* as follows:**Page 5-8, Article 505-1 DESCRIPTION, lines 4-6**, replace the paragraph with the following:

Construct aggregate subgrades in accordance with the contract. Install geotextile for soil stabilization and place Class IV subgrade stabilization at locations shown in the plans and as directed.

Undercut natural soil materials if necessary to construct aggregate subgrades. Define “subbase” as the portion of the roadbed below the Class IV subgrade stabilization. For Type 2 aggregate subgrades, undercut subbases as needed. The types of aggregate subgrade with thickness and compaction requirements for each are as shown below.

Type 1 – A 6 to 24 inch thick aggregate subgrade with Class IV subgrade stabilization compacted to 92% of AASHTO T 180 as modified by the Department or to the highest density that can be reasonably obtained.

Type 2 – An 8 inch thick aggregate subgrade on a proof rolled subbase with Class IV subgrade stabilization compacted to 97% of AASHTO T 180 as modified by the Department.

Page 5-8, Article 505-3 CONSTRUCTION METHODS, line 12, insert the following after the first sentence of the first paragraph:

For Type 2 aggregate subgrades, proof roll subbases in accordance with Section 260 before installing geotextile for soil stabilization.

Page 5-8, Article 505-3 CONSTRUCTION METHODS, lines 16-17, replace the last sentence of the first paragraph with the following:

Compact ABC as required for the type of aggregate subgrade constructed.

Page 5-8, Article 505-4 MEASUREMENT AND PAYMENT, line 26, insert the following after the last sentence of the first paragraph:

Undercut Excavation of natural soil materials from subbases for Type 2 aggregate subgrades will be measured and paid in accordance with Article 225-7 or 226-3. No measurement will be made for any undercut excavation of fill materials from subbases.



DocuSigned by:
John Pilipchuk
 52C44B94B8BE444...
 07/06/2023

R-5799

GT-4.1

Transylvania County

SOLDIER PILE RETAINING WALLS**(10-19-21)****1.0 GENERAL**

Construct soldier pile retaining walls consisting of driven or drilled-in steel H-piles with either precast concrete panels in between piles or a CIP reinforced concrete face attached to front of piles unless required otherwise in the plans. Timber lagging is typically used for temporary support of excavations during construction. Provide CIP reinforced concrete coping as required. Design and construct soldier pile retaining walls based on actual elevations and wall dimensions in accordance with the contract and accepted submittals. Use a prequalified Cantilever Wall Contractor to construct soldier pile retaining walls. Define "soldier pile wall" as a soldier pile retaining wall. Define "panel" as a precast concrete panel and "concrete facing" as a CIP reinforced concrete face. Define "pile" as a steel H-pile and "coping" as CIP concrete coping.

2.0 MATERIALS

Refer to the *Standard Specifications*.

Item	Section
Asphalt Concrete Base Course, Type B25.0C	620
Flowable Fill, Excavatable	1000-6
Geosynthetics	1056
Grout, Type 1	1003
Joint Materials	1028
Masonry	1040
Portland Cement Concrete	1000
Reinforcing Steel	1070
Retaining Wall Panels	1077
Select Materials	1016
Shoulder Drain Materials	816-2
Steel H-Piles	1084-1
Untreated Timber	1082-2
Welded Stud Shear Connectors	1072-6

Provide Type 2 geotextile for separation geotextiles and Class VI select material (standard size No. 57 stone) for leveling pads and backfilling. Use Class A concrete for concrete facing and coping and Class A concrete that meets Article 450-2 of the *Standard Specifications* or grout for drilled-in piles. Use untreated timber with a thickness of at least 3" and a bending stress of at least 1,000 psi for timber lagging.

Unless required otherwise in the contract, produce panels with a smooth flat final finish that meets Article 1077-11 of the *Standard Specifications*. When noted in the plans, produce panels with an exposed aggregate finish that meets Article 1077-12 of the *Standard Specifications*. Produce panels within 1/4" of the panel dimensions shown in the accepted submittals. Damaged panels with excessive discoloration, chips or cracks as determined by the Engineer will be rejected.

For soldier pile walls with panels, galvanize piles in accordance with Section 1076 of the *Standard Specifications*. When noted in the plans, paint galvanized piles in accordance with Article 442-13 of the *Standard Specifications*. Apply the following system to paint galvanized piles gray with waterborne paints that meet Article 1080-9 of the *Standard Specifications*. For painting galvanized piles other colors, contact the Materials and Tests (M&T) Unit for an appropriate paint system.

GRAY PAINT SYSTEM FOR GALVANIZED PILES			
Coat	Color	Dry/Wet Film Thickness (Mils)	
		Min.	Max.
Intermediate	Brown	3.0 DFT	5.0 DFT
Stripe	White	4.0 WFT	7.0 WFT
Topcoat	Gray	2.0 DFT	4.0 DFT
Total		5.0 DFT	9.0 DFT

Store steel materials on blocking at least 12" above the ground and protect it at all times from damage; and when placing in the work make sure it is free from dirt, dust, loose mill scale, loose rust, paint, oil or other foreign materials. Load, transport, unload and store soldier pile wall materials so materials are kept clean and free of damage. Bent, damaged or defective materials will be rejected.

3.0 PRECONSTRUCTION REQUIREMENTS

A. Soldier Pile Wall Surveys

The Retaining Wall Plans show a plan view, typical sections, details, notes and an elevation or profile view (wall envelope) for each soldier pile wall. Before beginning soldier pile wall design, survey existing ground elevations shown in the plans and other elevations in the vicinity of soldier pile wall locations as needed. For proposed slopes above or below soldier pile walls, survey existing ground elevations to at least 10 ft beyond slope stake points. Based on these elevations, finished grades and actual soldier pile wall dimensions and details, submit revised wall envelopes for acceptance. Use accepted wall envelopes for design.

B. Soldier Pile Wall Designs

For soldier pile wall designs, submit PDF files of working drawings and design calculations at least 30 days before the preconstruction meeting. Do not begin soldier pile wall construction until a design submittal is accepted.

Use a prequalified Cantilever Wall Design Consultant to design soldier pile walls. Provide designs sealed by a Design Engineer approved as a Geotechnical Engineer (key person) for the Cantilever Wall Design Consultant.

Design soldier pile walls in accordance with the plans and Article 11.8 of the *AASHTO LRFD Bridge Design Specifications* unless otherwise required. Design soldier pile walls

for a maximum deflection of 2" or 1.5% of H, whichever is less, with H as shown in the plans.

When noted in the plans, design soldier pile walls for a live load (traffic) surcharge of 250 psf in accordance with Article 11.5.6 of the AASHTO LRFD specifications. For steel beam guardrail with 8 ft posts above soldier pile walls, analyze walls for a nominal horizontal load (P_{HI}) of 300 lb/ft of wall in accordance with Figure 3.11.6.3-2(a) of the AASHTO LRFD specifications. For concrete barrier rail above soldier pile walls, analyze walls for a nominal P_{HI} of 500 lb/ft of wall in accordance with Figure 3.11.6.3-2(a).

When a rock mass shear strength (S_m) is noted in the plans, analyze piles using the equation shown in Figure 3.11.5.6-2 of the AASHTO LRFD specifications to calculate the passive resistance of the rock ($\overline{P_p}$). Use a maximum H-pile spacing of 10 ft. At the Contractor's option, use driven or drilled-in piles for soldier pile walls with concrete facing unless otherwise required. For soldier pile walls with panels, use drilled-in piles unless noted otherwise in the plans. Use concrete or grout for embedded portions of drilled-in piles. Install drilled-in piles by excavating holes with diameters that will result in at least 3" of clearance all around piles.

Provide temporary support of excavations for excavations more than 4 ft deep and timber lagging in accordance with the *AASHTO Guide Design Specifications for Bridge Temporary Works*. At the Contractor's option and when noted in the plans, provide temporary slopes instead of temporary support of excavations. Do not extend temporary slopes outside right-of-way or easement limits. Except for fill sections or when using temporary slopes, backfill voids behind panels, lagging and piles with No. 57 stone. Separation geotextiles are required between No. 57 stone and overlying fill sections. When placing pavement sections directly on No. 57 stone, cap stone with 4" of asphalt concrete base course.

At the Contractor's option, use panels or concrete facing unless required otherwise in the plans. Design panels and concrete facing in accordance with the plans and Section 5 of the *AASHTO LRFD Bridge Design Specifications*. Provide reinforcing steel of sufficient density to satisfy Article 5.7.3.4 of the AASHTO LRFD specifications. Use panels or concrete facing with the dimensions shown in the plans and attach facing to front of H-piles with welded stud shear connectors.

Use No. 57 stone for aggregate leveling pads. Use 6" thick leveling pads beneath panels and concrete facing. Unless required otherwise in the plans, embed top of leveling pads at least 12" below bottom of walls shown in the plans.

Provide wall drainage systems consisting of geocomposite sheet drains, an aggregate shoulder drain and outlet components. Place sheet drains with a horizontal spacing of no more than 10 ft and center drains between adjacent piles. Attach sheet drains to front of timber lagging or back of panels or concrete facing and connect drains to aggregate leveling pads. Locate a continuous aggregate shoulder drain along the base of panels or concrete facing in front of piles and leveling pads. Provide aggregate shoulder drains

and outlet components in accordance with Roadway Standard Drawing No. 816.02.

Unless required otherwise in the plans, use CIP reinforced concrete coping at top of soldier pile walls with panels. Use coping dimensions shown in the plans and at the Contractor's option, connect coping to panels with dowels or extend coping down back of panels. When concrete barrier rail is required above soldier pile walls, use concrete barrier rail with moment slab as shown in the plans.

Submit working drawings and design calculations for acceptance in accordance with Article 105-2 of the *Standard Specifications*. Submit working drawings showing plan views, wall profiles with pile locations, typical sections and details of piles, drainage, temporary support, leveling pads, panels and concrete facing. If necessary, include details on working drawings for coping, concrete barrier rail with moment slab and obstructions extending through walls or interfering with piles, barriers or moment slabs. Submit design calculations including deflection calculations for each wall section with different surcharge loads, geometry or material parameters. Include analysis of temporary conditions in design calculations. When designing soldier pile walls with computer software, a hand calculation is required for the tallest wall section.

C. Soldier Pile Wall Construction Plan

Submit a PDF file of a soldier pile wall construction plan at least 30 days before the preconstruction meeting. Do not begin soldier pile wall construction until the construction plan submittal is accepted. Provide project specific information in the soldier pile wall construction plan including a detailed construction sequence. For driven piles, submit proposed pile driving methods and equipment in accordance with Subarticle 450-3(D)(2) of the *Standard Specifications*. For drilled-in piles, submit installation details including drilling equipment and methods for stabilizing and filling holes. Provide details in the construction plan of excavations including temporary support and any other information shown in the plans or requested by the Engineer.

If alternate construction procedures are proposed or necessary, a revised soldier pile wall construction plan submittal may be required. If the work deviates from the accepted submittal without prior approval, the Engineer may suspend soldier pile wall construction until a revised plan is accepted.

D. Preconstruction Meeting

Before starting soldier pile wall construction, hold a preconstruction meeting to discuss the construction and inspection of the soldier pile walls. If this meeting occurs before all soldier pile wall submittals have been accepted, additional preconstruction meetings may be required before beginning construction of soldier pile walls without accepted submittals. The Resident or Bridge Maintenance Engineer, Area Construction Engineer, Geotechnical Operations Engineer, Contractor and Cantilever Wall Contractor Superintendent will attend preconstruction meetings.

4.0 CONSTRUCTION METHODS

R-5799

GT-4.5

Transylvania County

Control drainage during construction in the vicinity of soldier pile walls. Direct run off away from soldier pile walls and areas above and behind walls. Contain and maintain No. 57 stone and backfill and protect material from erosion.

Notify the Engineer before blasting in the vicinity of soldier pile walls. Perform blasting in accordance with the contract. Unless required otherwise in the plans, install foundations located behind soldier pile walls before beginning wall construction if the horizontal distance to the closest foundation is less than the height of the tallest wall section.

Install soldier pile walls in accordance with the accepted submittals and as directed. Do not excavate behind soldier pile walls unless a temporary slope is shown in the accepted submittals. If overexcavation occurs and is not approved, repair walls with an approved method and a revised soldier pile wall design or construction plan may be required.

A. Piles

If a temporary slope is shown in the accepted submittals, excavate the slope before installing piles. Otherwise, install piles before excavating for soldier pile walls. Weld stud shear connectors to piles in accordance with Article 1072-6 of the *Standard Specifications*.

Install piles within 1" of horizontal and vertical alignment shown in the accepted submittals and with no negative batter (piles leaning forward). Minimize alignment variations between piles for soldier pile walls with concrete facing since variations can result in thicker concrete facing in some locations in order to provide the minimum required facing thickness elsewhere. Locate piles so the minimum required concrete facing thickness, if applicable, and roadway clearances are maintained for variable pile alignments.

Install piles to the required elevations in accordance with Subarticles 450-3(D) and 450-3(E) of the *Standard Specifications*. Piles may be installed with a vibratory hammer as approved by the Engineer. Do not splice piles. If necessary, cut off piles at elevations shown in the accepted submittals along a plane normal to the pile axis.

Use pile excavation to install drilled-in piles. If overexcavation occurs, fill to required elevations with No. 57 stone before setting piles. After filling holes with concrete or grout to the elevations shown in the accepted submittals, remove any fluids and fill remaining portions of holes with flowable fill. Cure concrete or grout at least 7 days before excavating.

Notify the Engineer if refusal is reached before pile excavation or driven piles attain the required penetration. When this occurs, a revised soldier pile wall design or construction plan submittal may be required. When a minimum pile penetration into rock is noted in the plans, rock is as determined by the Engineer.

B. Excavation

If a temporary slope is shown in the accepted submittals, excavate the slope as shown.

R-5799

GT-4.6

Transylvania County

Otherwise, excavate in front of piles from the top down in accordance with the accepted submittals. Excavate in staged horizontal lifts with a maximum height of 5 ft. Use timber lagging or an alternate approved method for temporary support of excavations in accordance with the accepted submittals.

Install temporary support within 24 hours of excavating each lift unless otherwise approved. The installation may be delayed if it can be demonstrated that delays will not adversely affect excavation stability. If excavation faces will be exposed for more than 24 hours, use polyethylene sheets anchored at top and bottom of lifts to protect excavation faces from changes in moisture content.

If an excavation becomes unstable at any time, suspend soldier pile wall construction and temporarily stabilize the excavation by immediately placing an earth berm up against the unstable excavation face. When this occurs, repair walls with an approved method and a revised soldier pile wall design or construction plan may be required.

Remove flowable fill and material in between piles as necessary to install timber lagging. Position lagging with at least 3" of contact in the horizontal direction between the lagging and pile flanges. Do not excavate the next lift until temporary support for the current lift is accepted.

C. Wall Drainage Systems

Install wall drainage systems as shown in the accepted submittals and in accordance with Section 816 of the *Standard Specifications*. Place geocomposite sheet drains with the geotextile side facing away from wall faces. Secure sheet drains so drains are in continuous contact with surfaces to which they are attached and allow for full flow the entire height of soldier pile walls. Discontinuous sheet drains are not allowed. If splices are needed, overlap sheet drains at least 12" so flow is not impeded. Connect sheet drains to aggregate leveling pads by embedding drain ends at least 4" into No. 57 stone.

D. Leveling Pads, Panels, Coping and Concrete Facing

Construct aggregate leveling pads at elevations and with dimensions shown in the accepted submittals. Compact leveling pads with a vibratory compactor to the satisfaction of the Engineer.

Set panels against pile flanges as shown in the accepted submittals. Position panels with at least 2" of contact in the horizontal direction between the panels and pile flanges. If contact cannot be maintained, remove panels, fill gaps with joint filler and reset panels. Securely support panels until enough No. 57 stone or backfill is placed to hold panels in place.

Construct coping as shown in the accepted submittals and Subarticle 452-4(B) of the *Standard Specifications*. When single faced precast concrete barrier is required in front of and against soldier pile walls, stop coping just above barrier so coping does not interfere with placing barrier up against wall faces. If the gap between a single faced barrier and wall face is wider than 2", fill gap with Class V select material (standard size

R-5799

GT-4.7

Transylvania County

No. 78M stone). Otherwise, fill gap with backer rod and seal joint between barrier and soldier pile wall with silicone sealant.

Construct concrete facing in accordance with the accepted submittals and Section 420 of the *Standard Specifications*. Do not remove forms until concrete attains a compressive strength of at least 2,400 psi. Unless required otherwise in the plans, provide a Class 2 surface finish for concrete facing that meets Subarticle 420-17(F) of the *Standard Specifications*. Construct concrete facing joints at a spacing of 10 ft to 12 ft unless required otherwise in the plans. Make 1/2" thick expansion joints that meet Article 420-10 of the *Standard Specifications* for every third joint and 1/2" deep grooved contraction or sawed joints that meet Subarticle 825-10(B) or 825-10(E) respectively for the remaining joints. Stop reinforcing steel for concrete facing 2" on either side of expansion joints.

If a brick veneer is required, construct brick masonry in accordance with Section 830 of the *Standard Specifications*. Anchor brick veneers to soldier pile walls in accordance with Subarticle 453-4 of the *Standard Specifications*. Seal joints above and behind soldier pile walls between coping or concrete facing and concrete slope protection with silicone sealant.

E. Backfill

For fill sections or if a temporary slope is shown in the accepted submittals, backfill behind piles, panels and concrete facing in accordance with Article 410-8 of the *Standard Specifications*. Backfill voids behind panels, lagging and piles with No. 57 stone as shown in the accepted submittals. Ensure all voids between panels and lagging and between piles, lagging and excavation faces are filled with No. 57 stone. Compact stone to the satisfaction of the Engineer. When separation geotextiles are required, overlap adjacent geotextiles at least 18" and hold separation geotextiles in place with wire staples or anchor pins as needed.

F. Pile Coatings

For soldier pile walls with panels, clean exposed galvanized or painted surfaces of piles with a 2,500 psi pressure washer after wall construction is complete. Repair galvanized surfaces that are exposed and damaged in accordance with Article 1076-7 of the *Standard Specifications*. Repair painted surfaces that are exposed and damaged by applying 4.0 to 7.0 mils wet film thickness of a topcoat to damaged areas with brushes or rollers. Use the same paint for damaged areas that was used for the topcoat when painting piles initially. Feather or taper topcoats in damaged areas to be level with surrounding areas.

5.0 MEASUREMENT AND PAYMENT

Soldier Pile Retaining Walls will be measured and paid in square feet. Soldier pile walls will be measured as the square feet of wall face area with the pay height equal to the difference between top of wall and top of leveling pad elevations. Define "top of wall" as top of coping or top of panels or concrete facing for soldier pile walls without coping.

R-5799

GT-4.8

Transylvania County

The contract unit price for *Soldier Pile Retaining Walls* will be full compensation for providing designs, submittals, labor, tools, equipment and soldier pile wall materials, installing piles, excavating, hauling and removing excavated materials, placing and compacting No. 57 stone and backfill material and supplying temporary support of excavations, wall drainage systems, leveling pads, panels, concrete facing, No. 57 stone, geotextiles, aggregate concrete base course and any incidentals necessary to construct soldier pile walls. The contract unit price for *Soldier Pile Retaining Walls* will also be full compensation for coping, pile coatings, backer rod and silicone sealant, No. 78M stone and brick veneers, if required. No additional payment will be made and no extension of completion date or time will be allowed for repairing overexcavations or unstable excavations or thicker concrete facing.

The contract unit price for *Soldier Pile Retaining Walls* does not include the cost for ditches, fences, handrails, barrier or guardrail associated with soldier pile walls as these items will be paid for elsewhere in the contract.

Where it is necessary to provide backfill material behind soldier pile walls from sources other than excavated areas or borrow sources used in connection with other work in the contract, payment for furnishing and hauling such backfill material will be paid as extra work in accordance with Article 104-7 of the *Standard Specifications*. Placing and compacting such backfill material is not considered extra work but is incidental to the work being performed.

Payment will be made under:

Pay Item
Soldier Pile Retaining Walls

Pay Unit
Square Foot



7/13/2023

MECHANICALLY STABILIZED EARTH RETAINING WALLS**(10-19-21)****1.0 GENERAL**

Construct mechanically stabilized earth (MSE) retaining walls consisting of steel or geosynthetic reinforcement in the reinforced zone connected to vertical facing elements. Use precast concrete panels for vertical facing elements and coarse aggregate in the reinforced zone unless noted otherwise in the plans. Provide reinforced concrete coping and pile sleeves as required. Design and construct MSE retaining walls based on actual elevations and wall dimensions in accordance with the contract and accepted submittals. Use a prequalified MSE Wall Installer to construct MSE retaining walls.

Define MSE wall terms as follows:

Geosynthetic Reinforcement – Polyester Type (PET), HDPE or Polypropylene (PP) geosynthetic grids, i.e., geogrid reinforcement or polymer straps, i.e., geostrip reinforcement,

Geogrid – PET, HDPE or PP geogrid,

Reinforcement – Steel or geosynthetic reinforcement,

Aggregate – Coarse or fine aggregate,

Panel – Precast concrete panel,

Coping – Precast or CIP concrete coping,

Design Height (H) – Wall height + wall embedment as shown in the plans,

MSE Wall – Mechanically stabilized earth retaining wall,

MSE Wall Vendor – Vendor supplying the chosen MSE wall system,

MSE Panel Wall – MSE wall with panels,

MSE Segmental Wall – MSE wall with segmental retaining wall (SRW) units and

Abutment Wall – MSE wall with bridge foundations in any portion of the reinforced zone or an MSE wall connected to an abutment wall (even if bridge foundations only penetrate a small part of the reinforced zone, the entire MSE wall is considered an abutment wall).

For bridge approach fills behind end bents with MSE abutment walls, design reinforcement connected to end bent caps in accordance with the plans and this provision. Construct Type III Reinforced Bridge Approach Fills in accordance with the *Bridge Approach Fills* provision and Roadway Detail Drawing No. 422D10.

Use an approved MSE wall system in accordance with the plans and any NCDOT restrictions or exceptions for the chosen system. Value engineering proposals for other MSE wall systems will not be considered. Do not use MSE wall systems with an “approved for provisional use” status for MSE walls with design heights greater than 35 ft or walls supporting or adjacent to railroads or interstate highways. The list of approved MSE wall systems with approval status is available from:

connect.ncdot.gov/resources/Geological/Pages/Products.aspx

2.0 MATERIALS

Refer to the *Standard Specifications*.

Item
Aggregate

Section
1014

R-5799

GT-5.2

Transylvania County

Asphalt Concrete Base Course, Type B25.0C	620
Corrugated Steel Pipe	1032-3
Epoxy, Type 3A	1081
Geosynthetics	1056
Grout, Type 3	1003
Joint Materials	1028
Portland Cement Concrete, Class A	1000
Precast Retaining Wall Coping	1077
Reinforcing Steel	1070
Retaining Wall Panels	1077
Segmental Retaining Wall Units	1040-4
Select Material, Class V	1016
Shoulder Drain Materials	816-2
Steel Pipe	1036-4(A)

Use galvanized corrugated steel pipe with a zinc coating weight of 2 oz/sf (G200) for pile sleeves. Provide Type 2 geotextile for filtration and separation geotextiles. Use Class A concrete for CIP coping, leveling concrete and pads. Use galvanized steel pipe, threaded rods and nuts for the PET geogrid reinforcement vertical obstruction detail. Provide galvanized Grade 36 anchor rods and Grade A hex nuts that meet AASHTO M 314 for threaded rods and nuts.

Use panels and SRW units from producers approved by the Department and licensed by the MSE Wall Vendor. Provide steel strip connectors embedded in panels fabricated from structural steel that meets the requirements for steel strip reinforcement. Unless required otherwise in the contract, produce panels with a smooth flat final finish that meets Article 1077-11 of the *Standard Specifications*. Accurately locate and secure reinforcement connectors in panels and maintain required concrete cover. Produce panels within 1/4" of the panel dimensions shown in the accepted submittals.

Damaged panels or SRW units with excessive discoloration, chips or cracks as determined by the Engineer will be rejected. Do not damage reinforcement connection devices or mechanisms in handling or storing panels and SRW units.

Store steel materials on blocking at least 12" above the ground and protect it at all times from damage; and when placing in the work make sure it is free from dirt, dust, loose mill scale, loose rust, paint, oil or other foreign materials. Handle and store geosynthetics in accordance with Article 1056-2 of the *Standard Specifications*. Load, transport, unload and store MSE wall materials so materials are kept clean and free of damage. Bent, damaged or defective materials will be rejected.

A. Aggregate

Use standard size No. 57, 57M, 67 or 78M that meets Table 1005-1 of the *Standard Specifications* for coarse aggregate and the following for fine aggregate:

1. Standard size No. 1S, 2S, 2MS or 4S that meets Table 1005-2 of the *Standard Specifications* or

R-5799

GT-5.3

Transylvania County

2. Gradation that meets Class III, Type 3 select material in accordance with Article 1016-3 of the *Standard Specifications*.

Fine aggregate is exempt from mortar strength in Subarticle 1014-1(E) of the *Standard Specifications*. Use fine aggregate with a maximum organic content of 1.0%. Provide aggregate with chemical properties that meet the following requirements:

AGGREGATE pH REQUIREMENTS		
Aggregate Type (in reinforced zone)	Reinforcement or Connector Material	pH
Coarse or Fine	Steel	5 – 10
Coarse or Fine	Geosynthetic	4.5 – 9

AGGREGATE ELECTROCHEMICAL REQUIREMENTS (Steel Reinforcement/Connector Materials Only)			
Aggregate Type (in reinforced zone)	Resistivity	Chlorides	Sulfates
Coarse	$\geq 5,000 \Omega \cdot \text{cm}$	$\leq 100 \text{ ppm}$	$\leq 200 \text{ ppm}$
Fine	$\geq 3,000 \Omega \cdot \text{cm}$		

Use aggregate from sources participating in the Department's Aggregate QC/QA Program as described in Section 1006 of the *Standard Specifications*. Sample and test aggregate in accordance with the *Mechanically Stabilized Earth Wall Aggregate Sampling and Testing Procedures*.

B. Reinforcement

Provide steel or geosynthetic reinforcement supplied by the MSE Wall Vendor or a manufacturer approved or licensed by the vendor. Use reinforcement approved for the chosen MSE wall system. The list of approved reinforcement for each MSE wall system is available from the website shown elsewhere in this provision.

1. Steel Reinforcement

Provide Type 1 material certifications in accordance with Article 106-3 of the *Standard Specifications* for steel reinforcement. Use welded wire grid reinforcement ("mesh", "mats" and "ladders") that meet Article 1070-3 of the *Standard Specifications* and steel strip reinforcement ("straps") that meet ASTM A572, A1011 or A463. Use 10 gauge or heavier structural steel Grade 50 or higher for steel strip reinforcement. Galvanize steel reinforcement in accordance with Section 1076 of the *Standard Specifications* or provide aluminized steel strip reinforcement that meet ASTM A463, Type 2-100.

2. Geosynthetic Reinforcement

Provide Type 1 material certifications and identify geosynthetic reinforcement in

R-5799

GT-5.4

Transylvania County

accordance with Article 1056-3 of the *Standard Specifications*. Define machine direction (MD) and cross-machine direction (CD) for geogrids per Article 1056-3 of the *Standard Specifications*.

Use HDPE or PP geogrid for geogrid reinforcement cast into backwalls of end bent caps. Use PET or HDPE geogrid for geogrid reinforcement connected directly to SRW units and only HDPE geogrid for geogrid reinforcement cast into panels.

Provide extruded geogrids produced in the United States and manufactured from punched and drawn polypropylene sheets for PP geogrids that meet the following:

PP GEOGRID REQUIREMENTS		
Property	Requirement¹	Test Method
Aperture Dimensions ²	1" x 1.2"	N/A
Minimum Rib Thickness ²	0.07" x 0.07"	N/A
Tensile Strength @ 2% Strain ²	580 lb/ft x 690 lb/ft	ASTM D6637, Method B
Tensile Strength @ 5% Strain ²	1,200 lb/ft x 1,370 lb/ft	
Ultimate Tensile Strength ²	1,850 lb/ft x 2,050 lb/ft	
Junction Efficiency ³ (MD)	93%	ASTM D7737
Flexural Rigidity ⁴	2,000,000 mg-cm	ASTM D7748
Aperture Stability Modulus ⁵	0.55 lb-ft/degrees	ASTM D7864
UV Stability (Retained Strength)	100% (after 500 hr of exposure)	ASTM D4355

- MARV per Article 1056-3 of the *Standard Specifications* except dimensions and thickness are nominal.
- Requirement for MD x CD.
- Junction Efficiency (%) = (Average Junction Strength ($X_{j,ave}$) / Ultimate Tensile Strength in the MD from ASTM D6637, Method A) \times 100.
- Test specimens two ribs wide, with transverse ribs cut flush with exterior edges of longitudinal ribs, and sufficiently long to enable measurement of the overhang dimension.
- Applied moment of 17.7 lb-inch (torque increment).

C. Bearing Pads

For MSE panel walls, use preformed ethylene propylene diene monomer rubber bearing pads that meet ASTM D2000 Grade 2, Type A, Class A with a durometer hardness of 60 or 80 ± 5 . Provide bearing pads with thicknesses that meet the following:

BEARING PAD THICKNESS	
Facing Area per Panel (A)	Minimum Pad Thickness After Compression (based on 2 times panel weight above pads)
$A \leq 30$ sf	1/2"
$30 \text{ sf} < A \leq 75$ sf	3/4"

D. Miscellaneous Components

Miscellaneous components may include connectors (e.g., anchors, bars, clamps, pins, plates, ties, etc.), fasteners (e.g., bolts, nuts, washers, etc.) and any other MSE wall components not included above. Use 10 gauge or heavier structural steel Grade 50 or higher for steel strip panel anchors and connectors. Galvanize steel components in accordance with Section 1076 of the *Standard Specifications*. Provide miscellaneous components approved for the chosen MSE wall system. The list of approved miscellaneous components for each MSE wall system is available from the website shown elsewhere in this provision.

3.0 PRECONSTRUCTION REQUIREMENTS

A. MSE Wall Surveys

The Retaining Wall Plans show a plan view, typical sections, details, notes and an elevation or profile view (wall envelope) for each MSE wall. Before beginning MSE wall design, survey existing ground elevations shown in the plans and other elevations in the vicinity of MSE wall locations as needed. For proposed slopes above or below MSE walls, survey existing ground elevations to at least 10 ft beyond slope stake points. Based on these elevations, finished grades and actual MSE wall dimensions and details, submit revised wall envelopes for acceptance. Use accepted wall envelopes for design.

B. MSE Wall Designs

For MSE wall designs, submit PDF files of working drawings and design calculations at least 30 days before the preconstruction meeting. Note name and NCDOT ID number of the panel or SRW unit production facility on working drawings. Do not begin MSE wall construction until a design submittal is accepted.

Use a prequalified MSE Segmental Wall Design Consultant to design MSE segmental walls. Provide MSE segmental wall designs sealed by a Design Engineer approved as a Geotechnical Engineer (key person) for the MSE Segmental Wall Design Consultant. Provide MSE panel wall designs sealed by a Design Engineer licensed in the state of North Carolina and employed or contracted by the MSE Wall Vendor.

Design MSE walls in accordance with the plans, *AASHTO LRFD Bridge Design Specifications* and any NCDOT restrictions for the chosen MSE wall system unless otherwise required. For abutment walls only, design MSE walls for seismic if wall sites meet either or both of the following:

- Wall site is in seismic zone 2 based on Figure 2-1 of the *Structure Design Manual*,
- Wall site is classified as AASHTO Site Class E, as noted in the plans, and is in or west of Pender, Duplin, Wayne, Johnston, Wake, Durham or Person County.

Connect reinforcement to panels or SRW units with methods or devices approved for the chosen system. Use a uniform reinforcement length throughout the height of the wall of at least $0.7H$ or 6 ft, whichever is longer, unless noted otherwise in the plans. Extend the reinforced zone at least 6" beyond end of reinforcement. Do not locate drains, the reinforced zone or leveling pads outside right-of-way or easement limits.

Use the simplified method for determining maximum reinforcement loads and design parameters approved for the chosen MSE wall system or default values in accordance with the AASHTO LRFD specifications. Design steel components including reinforcement and connectors for the design life noted in the plans and aggregate type in the reinforced zone. If an MSE wall system with geosynthetic reinforcement includes any steel parts for obstructions, bin walls, connections or other components, design steel exposed to aggregate for the design life noted in the plans and aggregate type in the reinforced zone. Use “loss of galvanizing” metal loss rates for nonaggressive backfill in accordance with the AASHTO LRFD specifications for galvanized and aluminized steel and metal loss rates for carbon steel in accordance with the following:

CARBON STEEL CORROSION RATES	
Aggregate Type (in reinforced zone)	Carbon Steel Loss Rate (after coating depletion)
Coarse	0.47 mil/year
Fine (except abutment walls)	0.58 mil/year
Fine (abutment walls)	0.70 mil/year

For PET or HDPE geogrid and geostrip reinforcement and geosynthetic connectors, use approved geosynthetic properties for the design life noted in the plans and aggregate type in the reinforced zone. For geogrid reinforcement connected to end bent caps, embed reinforcement or connectors in caps as shown in the plans. For PP geogrid reinforcement connected to end bent caps, use the following design parameters for the aggregate type in the reinforced approach fill.

PP GEOGRID REINFORCEMENT DESIGN PARAMETERS				
Aggregate Type (in reinforced zone)	T_{al} (MD)	F*	α	ρ
Coarse	400 lb/ft	0.70	0.8	32.0°
Fine	428 lb/ft	0.54	0.8	28.35°

Where,

- T_{al} = long-term design strength (LTDS),
 F* = pullout resistance factor,
 α = scale effect correction factor and
 ρ = soil-geogrid friction angle.

When noted in the plans, design MSE walls for a live load (traffic) surcharge of 250 psf in accordance with Figure C11.5.6-3(b) of the AASHTO LRFD specifications. For steel beam guardrail with 8 ft posts or concrete barrier rail above MSE walls, analyze top 2 reinforcement layers for traffic impact loads in accordance with Section 7.2 of *FHWA Design and Construction of Mechanically Stabilized Earth Walls and Reinforced Soil Slopes – Volume I* (Publication No. FHWA-NHI-10-024) except use the following for geosynthetic reinforcement rupture:

$$\phi T_{al} R_c \geq T_{max} + (T_I / RF_{CR})$$

Where,

R-5799

GT-5.7

Transylvania County

ϕ	=	resistance factor for tensile resistance in accordance with Section 7.2.1 of the FHWA MSE wall manual,
T_{al}	=	long-term geosynthetic design strength approved for chosen MSE wall system,
R_c	=	reinforcement coverage ratio = 1 for continuous geosynthetic reinforcement,
T_{max}	=	factored static load in accordance with Section 7.2 of the FHWA MSE wall manual,
T_I	=	factored impact load in accordance with Section 7.2 of the FHWA MSE wall manual and
RF_{CR}	=	creep reduction factor approved for chosen MSE wall system.

When shown in the plans for abutment walls, use pile sleeves to segregate piles from aggregate in the reinforced zone. If existing or future obstructions such as foundations, guardrail, fence or handrail posts, moment slabs, pavements, pipes, inlets or utilities will interfere with reinforcement, maintain a clearance of at least 3" between obstructions and reinforcement unless otherwise approved. Design reinforcement for obstructions and locate reinforcement layers so all of reinforcement length is within 3" of corresponding connection elevations. Modify PET geogrid reinforcement for obstructions as shown in the plans.

Use 6" thick CIP unreinforced concrete leveling pads beneath panels and SRW units that are continuous at steps and extend at least 6" in front of and behind bottom row of panels or SRW units. Unless required otherwise in the plans, embed top of leveling pads in accordance with the following requirements:

WALL EMBEDMENT REQUIREMENTS		
Front Slope¹ (H:V)	Minimum Embedment Depth² (whichever is greater)	
6:1 or flatter (except abutment walls)	H/20	1 ft for H ≤ 10 ft 2 ft for H > 10 ft
6:1 or flatter (abutment walls)	H/10	2 ft
> 6:1 to < 3:1	H/10	2 ft
3:1 to 2:1	H/7	2 ft

1. Front slope is as shown in the plans.
2. H is the maximum design height per wall.

When noted in the plans, locate a continuous aggregate shoulder drain along the base of the reinforced zone behind the aggregate. Provide wall drainage systems consisting of drains and outlet components in accordance with Roadway Standard Drawing No. 816.02.

For MSE panel walls, cover joints at back of panels with filtration geotextiles at least 12" wide. If the approval of the chosen MSE wall system does not require a minimum number of bearing pads, provide the number of pads in accordance with the following:

NUMBER OF BEARING PADS

R-5799

GT-5.8

Transylvania County

Facing Area per Panel (A)	Maximum Height of Wall Above Horizontal Panel Joint	Minimum Number of Pads per Horizontal Panel Joint
$A \leq 30$ sf	25 ft	2
	35 ft ¹	3
$30 \text{ sf} < A \leq 75$ sf	25 ft	3
	35 ft ¹	4

1. Additional bearing pads per horizontal panel joint may be required for wall heights above joints greater than 35 ft.

For MSE segmental walls, coarse aggregate is required in any SRW unit core spaces and between and behind SRW units for a horizontal distance of at least 18".

Separation geotextiles are required between the aggregate and overlying fill sections. When noted in the plans, separation geotextiles are also required at the back of the reinforced zone between the aggregate and backfill or natural ground. When placing pavement sections directly on the reinforced zone, cap aggregate with 4" of asphalt concrete base course. Unless required otherwise in the plans, use reinforced concrete coping at top of walls that meets the following requirements:

1. Coping dimensions as shown in the plans,
2. At the Contractor's option, coping that is precast or CIP concrete for MSE panel walls unless CIP coping is required as shown in the plans,
3. CIP concrete coping for MSE segmental walls and
4. At the Contractor's option and when shown in the plans, CIP concrete coping that extends down back of panels or SRW units or connects to panels or SRW units with dowels.

For MSE segmental walls with dowels, attach dowels to top courses of SRW units in accordance with the following:

1. Set dowels in core spaces of SRW units filled with grout instead of coarse aggregate or
2. Embed adhesively anchored dowels in holes of solid SRW units with epoxy.

For MSE panel walls with coping, connect CIP concrete coping or leveling concrete for precast concrete coping to top row of panels with dowels cast into panels. When concrete barrier rail is required above MSE walls, use concrete barrier rail with moment slab as shown in the plans.

Submit working drawings and design calculations for acceptance in accordance with Article 105-2 of the *Standard Specifications*. Submit working drawings showing plan views, wall profiles with foundation pressures, typical sections with reinforcement and connection details, aggregate locations and types, geotextile locations and details of leveling pads, panels or SRW units, coping, bin walls, slip joints, pile sleeves, etc. If

necessary, include details on working drawings for concrete barrier rail with moment slab, reinforcement splices if allowed for the chosen MSE wall system, reinforcement connected to end bent caps, curved MSE walls with tight (short) radii and obstructions extending through walls or interfering with reinforcement, leveling pads, barriers or moment slabs. Submit design calculations for each wall section with different surcharge loads, geometry or material parameters. At least one analysis is required for each wall section with different reinforcement lengths. When designing MSE walls with computer software other than MSEW, use MSEW manufactured by ADAMA Engineering, Inc. to verify the design. At least one MSEW analysis is required per 100 ft of wall length with at least one analysis for the wall section with the longest reinforcement. Submit electronic MSEW input files and PDF output files with design calculations.

C. Preconstruction Meeting

Before starting MSE wall construction, hold a preconstruction meeting to discuss the construction and inspection of the MSE walls. If this meeting occurs before all MSE wall submittals have been accepted, additional preconstruction meetings may be required before beginning construction of MSE walls without accepted submittals. The Resident or Bridge Maintenance Engineer, Area Construction Engineer, Geotechnical Operations Engineer, Contractor and MSE Wall Installer Superintendent will attend preconstruction meetings.

4.0 CORROSION MONITORING

Corrosion monitoring is required for MSE walls with steel reinforcement. The Engineer will determine the number of monitoring locations and where to install the instrumentation. Contact M&T before beginning wall construction. M&T will provide the corrosion monitoring instrumentation kits and if necessary, assistance with installation.

5.0 SITE ASSISTANCE

Unless otherwise approved, an MSE Wall Vendor representative is required to assist and guide the MSE Wall Installer on-site for at least 8 hours when the first panels or SRW units and reinforcement layer are placed. If problems are encountered during construction, the Engineer may require the vendor representative to return to the site for a time period determined by the Engineer.

6.0 CONSTRUCTION METHODS

Control drainage during construction in the vicinity of MSE walls. Direct run off away from MSE walls, aggregate and backfill. Contain and maintain aggregate and backfill and protect material from erosion.

Excavate as necessary for MSE walls in accordance with the accepted submittals. If applicable and at the Contractor's option, use temporary shoring for wall construction instead of temporary slopes to construct MSE walls. Define "temporary shoring for wall construction" as temporary shoring not shown in the plans or required by the Engineer including shoring for OSHA reasons or the Contractor's convenience.

R-5799

GT-5.10

Transylvania County

Unless required otherwise in the plans, install foundations and if required, pile sleeves located in the reinforced zone before placing aggregate or reinforcement. Brace piles in the reinforced zone to maintain alignment when placing and compacting aggregate. Secure piles together with steel members near top of piles. Clamp members to piles instead of welding if bracing is at or below pile cut-off elevations.

Notify the Engineer when foundation excavation is complete. Do not place leveling pad concrete, aggregate or reinforcement until excavation dimensions and foundation material are approved.

Construct CIP concrete leveling pads at elevations and with dimensions shown in the accepted submittals and in accordance with Section 420 of the *Standard Specifications*. Cure leveling pads at least 24 hours before placing panels or SRW units.

Erect and support panels and stack SRW units so the final wall position is as shown in the accepted submittals. Stagger SRW units to create a running bond by centering SRW units over joints in the row below as shown in the accepted submittals. Space bearing pads in horizontal panel joints as shown in the accepted submittals and cover all panel joints with filtration geotextiles as shown in the accepted submittals. Attach filtration geotextiles to back of panels with adhesives, tapes or other approved methods.

Construct MSE walls with the following tolerances:

- A. SRW units are level from front to back and between units when checked with a 4 ft long level,
- B. Vertical joint widths are 1/4" maximum for SRW units and 3/4", $\pm 1/4$ " for panels,
- C. Final wall face is within 3/4" of horizontal and vertical alignment shown in the accepted submittals when measured along a 10 ft straightedge and
- D. Final wall plumbness (batter) is not negative (wall face leaning forward) and within 0.5° of vertical unless otherwise approved.

Place reinforcement at locations and elevations shown in the accepted submittals and within 3" of corresponding connection elevations. Install reinforcement with the direction shown in the accepted submittals. Before placing aggregate, pull geosynthetic reinforcement taut so it is in tension and free of kinks, folds, wrinkles or creases. Reinforcement may be spliced once per reinforcement length if shown in the accepted submittals. Use reinforcement pieces at least 6 ft long. Contact the Engineer when unanticipated existing or future obstructions such as foundations, guardrail, fence or handrail posts, pavements, pipes, inlets or utilities will interfere with reinforcement. To avoid obstructions, deflect, skew or modify reinforcement as shown in the accepted submittals.

Place aggregate in the reinforced zone in 8" to 10" thick lifts. Compact fine aggregate in accordance with Subarticle 235-3(C) of the *Standard Specifications*. Use only hand operated compaction equipment to compact aggregate within 3 ft of panels or SRW units. At a distance greater than 3 ft, compact aggregate with at least 4 passes of an 8 ton to 10 ton vibratory roller in a direction parallel to the wall face. Smooth wheeled or rubber tired rollers are also acceptable for compacting aggregate. Do not use sheepsfoot, grid rollers or other

R-5799

GT-5.11

Transylvania County

types of compaction equipment with feet. Do not displace or damage reinforcement when placing and compacting aggregate. End dumping directly on geosynthetics is not permitted. Do not operate heavy equipment on reinforcement until it is covered with at least 8" of aggregate. Replace any damaged reinforcement to the satisfaction of the Engineer.

Backfill for MSE walls outside the reinforced zone in accordance with Article 410-8 of the *Standard Specifications*. If a drain is required, install wall drainage systems as shown in the accepted submittals and in accordance with Section 816 of the *Standard Specifications*. If pile sleeves are required, fill sleeves with loose uncompacted sand before constructing end bent caps.

Install dowels as necessary for SRW units and place and construct coping and leveling concrete as shown in the accepted submittals. Construct leveling concrete in accordance with Section 420 of the *Standard Specifications*. Construct CIP concrete coping in accordance with Subarticle 452-4(B) of the *Standard Specifications*. When single faced precast concrete barrier is required in front of and against MSE walls, stop coping just above barrier so coping does not interfere with placing barrier up against wall faces. If the gap between a single faced barrier and wall face is wider than 2", fill gap with Class V select material (standard size No. 78M stone). Otherwise, fill gap with backer rod and seal joint between barrier and MSE wall with silicone sealant.

When separation geotextiles are required, overlap adjacent geotextiles at least 18" and hold geotextiles in place with wire staples or anchor pins as needed. Seal joints above and behind MSE walls between coping and concrete slope protection with silicone sealant.

7.0 MEASUREMENT AND PAYMENT

MSE Retaining Wall No. ___ will be measured and paid in square feet. MSE walls will be measured as the square feet of wall face area with the pay height equal to the difference between top of wall and top of leveling pad elevations. Define "top of wall" as top of coping or top of panels or SRW units for MSE walls without coping.

The contract unit price for *MSE Retaining Wall No. ___* will be full compensation for providing designs, submittals, labor, tools, equipment and MSE wall materials, excavating, hauling and removing excavated materials, placing and compacting aggregate and backfill material and supplying site assistance, leveling pads, panels, SRW units, reinforcement, aggregate, wall drainage systems, geotextiles, aggregate concrete base course, bearing pads, coping, miscellaneous components and any incidentals necessary to construct MSE walls. The contract unit price for *MSE Retaining Wall No. ___* will also be full compensation for reinforcement and connector design for reinforcement connected to end bent caps, wall modifications for obstructions, pile sleeves filled with sand, joints sealed with silicone sealant and gaps between barriers and MSE walls filled with backer rod or No. 78M stone, if required.

No separate payment will be made for temporary shoring for wall construction. Temporary shoring for wall construction will be incidental to the contract unit price for *MSE Retaining Wall No. ___*.

R-5799

GT-5.12

Transylvania County

The contract unit price for *MSE Retaining Wall No.* ___ does not include the cost for ditches, fences, handrails, barrier or guardrail associated with MSE walls as these items will be paid for elsewhere in the contract. The contract unit price for *MSE Retaining Wall No.* ___ also does not include the cost for constructing bridge approach fills behind end bents with MSE abutment walls. See *Bridge Approach Fills* provision for measurement and payment of Type III Reinforced Bridge Approach Fills.

Where it is necessary to provide backfill material behind the reinforced zone from sources other than excavated areas or borrow sources used in connection with other work in the contract, payment for furnishing and hauling such backfill material will be paid as extra work in accordance with Article 104-7 of the *Standard Specifications*. Placing and compacting such backfill material is not considered extra work but is incidental to the work being performed.

Payment will be made under:

Pay Item

- MSE Retaining Wall No. 1
- MSE Retaining Wall No. 2
- MSE Retaining Wall No. 3

Pay Unit

- Square Foot
- Square Foot
- Square Foot



7/13/2023

NATURAL STONE VENEER**(SPECIAL)****1.0 GENERAL**

As required in the plans, the natural stone veneer (masonry) shall be in accordance with the plans and the Standard Specifications with the following additions and exceptions.

A. Quality Assurance

The masonry veneer is to consist of natural stone that is similar in color and origin to stones in the walls around the Brevard College, located at 1 Brevard College Drive, Brevard, North Carolina 28712 and the Historic Pisgah Forest Entrance shown below.



The stone is to be laid in a random pattern with raked jointing and a stone cap to replicate the patterns in within the historic stone masonry architecture of the Brevard College walls and surrounding area, or as directed by the Engineer.

Prior to construction of masonry work, actual stone samples or sections of stone shall be submitted for approval of color and texture. After approval, a sample veneer panel wall(s) shall be erected using proposed materials, and bond and joint tooling required for final work. Provide special features as directed for caulking and contiguous work. The sample panel(s) shall be built at the site, where directed, of full thickness and approximately 6.0 feet (L) x 4.0 feet (H), indicating the proposed range of color, texture and workmanship to be expected in the completed work. Written acceptance of visual qualities of the panel(s) shall be obtained prior to constructing any other masonry work.

An accepted panel shall be retained during construction as a standard for judging quality of completed masonry work. Approved panel shall not be altered, moved, or destroyed until all masonry work is completed. Sample panel may be used to test proposed cleaning procedures.

B. Protection of Work

Cold weather protection shall be in accordance with the Standard Specifications.

During erection, cover top of walls with heavy waterproof sheeting at end of each days' work. Cover partially completed structures when work is not in progress. Extend cover a minimum of 1.0 feet down both sides and hold cover securely in place.

Do not apply concentrated loads for at least 3 days after building masonry walls.

2.0 MATERIALS

A. Stone Masonry Units, General

Obtain natural Davidson River stone from one or more quarries as needed to produce a veneering that meets the criteria noted above.

B. Masonry Accessories

For masonry accessories, see the special provision entitled "Masonry Accessories".

C. Mortar

Mortar shall be in accordance with Section 830-3 of the Standard Specifications. The color of the mortar sand shall match as close as possible the mortar of other walls within the Courthouse area, or adjacent walls, as directed by the Engineer.

3.0 INSTALLATION

A. General

Build single-wythe veneer to maximum thickness of the masonry units, using units of nominal thickness shown or specified.

Using conventional stone masonry construction methods, stack and mortar stones as needed to create the specified appearance.

Wet stone having ASTM C-67 absorption rates greater than 25 gal./(min. x 19.4 mm²).

Frozen Materials and Work:

Do not use frozen materials or materials mixed or coated with ice or frost. For masonry which is specified to be wetted, comply with the BIA recommendations. Do not build on frozen work. Remove and replace masonry work damaged by frost or freezing.

Layout veneer in advance for accurate spacing of surface bond patterns, with varying joint widths to properly locate openings, movement-type joints, returns and offsets. Avoid the use of less-than-half size units at corners and where possible at other locations.

Lay-up stone veneer plumb and true and with courses level, accurately spaced and coordinated with other work.

Stopping and Resuming Work:

Rack back $\frac{1}{2}$ masonry unit length in each course; do not tooth. Clean exposed surfaces of set masonry, wet units lightly (if specified to be wetted), and remove loose masonry units and mortar prior to laying fresh masonry.

B. Batch Control

Measure/batch materials by volume or weight, such that required proportions for mortar can be accurately controlled and maintained. Measurement of sand by shovel will not be permitted.

Mix mortars with maximum amount of water consistent with workability to provide maximum tensile bond strength within the capacity of the mortar.

Mix mortar ingredients for a minimum of 3 minutes and a maximum of 5 minutes in a mechanical batch mixer. Use water clean/free of deleterious materials which would impair the work. Discard mortar which has begun to set, or if more than 2 hours has elapsed since initial mixing or $1\frac{1}{2}$ hr. in hot weather. Retemper mortar during first $1\frac{1}{2}$ hr. period as required to restore workability.

Lay stone units with completely filled bed, head and collar joints; butter ends with sufficient mortar to fill head joints and shove into place. Do not slush head joints.

C. Joints

Maintain consistent joint widths, except for minor variations required to maintain stone alignment. Create raked joints between stones. Rake out mortar in preparation for application of caulking or sealants as needed.

Remove stone masonry units disturbed after laying; clean and relay in fresh mortar. Do not pound corners at jambs to fit stretcher units which have been set in position. If adjustments are required, remove units, clean off mortar, and reset in fresh mortar.

D. Anchoring Stone Masonry Veneer Work

Anchor single wythe stone masonry veneer to backing with metal ties as follows:

Anchor veneer to precast panels with metal anchors attached to dovetail slots embedded into the concrete structure. Provide anchors with flexible tie section, unless otherwise indicated.

Space veneer anchors not more than 1.25 ft o.c. vertically and 2.0 ft o.c. horizontally. Provide additional anchors with 1.0 ft of openings and space not more than 3.0 ft around perimeter.

If dovetail anchors are placed in the soldier pile wall, space veneer anchors at each 5th stone course vertically and 2.0 ft o.c. horizontally.

E. Control and Expansion Joints

Provide vertical control joints in stone masonry as in common in the industry, shown on plans or as directed by the Engineer. Build-in related masonry accessory items as masonry work progresses.

F. Repair, Pointing and Cleaning

Replace stone masonry units which are loose, chipped broken, stained or otherwise damaged, or if units do not match adjoining units as intended.

Provide new units to match adjoining units and install in fresh mortar pointed to eliminate evidence of replacement.

During tooling of joints, enlarge any voids or holes, except weepholes, and completely fill with mortar. Point-up all joints at corners, openings and adjacent work to provide neat, uniform appearance, properly prepared for application of caulking or sealant compounds.

Clean exposed natural stone masonry surfaces by the bucket and brush, hand cleaning method or by high pressure water method.

4.0 BASIS OF PAYMENT

Payment for stone masonry veneer shall be paid per square foot contract price bid for the "Natural Stone Veneer" which price and payment shall be full compensation for all work covered by this special provision including but not limited to furnishing all materials (including native stone, mortar, masonry accessories, anchors, samples, etc.), labor tools, and equipment necessary for installing these units in place and accepted.

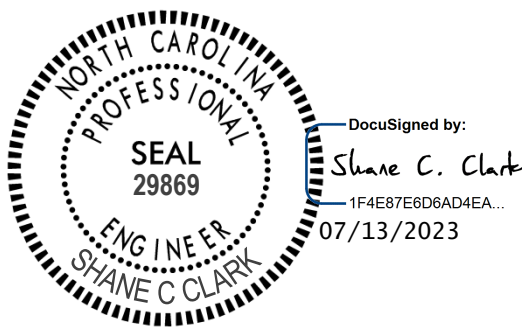

R-5799

TC-1

Transylvania County

**Project Special Provisions
Traffic Control**



7/11/2023

ADA COMPLIANT PEDESTRIAN TRAFFIC CONTROL DEVICES:

(10/31/2017) (Rev. 6/3/2022)

Description

Furnish, install, and maintain all ADA compliant pedestrian traffic control devices for existing pedestrian facilities that are disrupted, closed, or relocated by planned work activities.

The ADA compliant pedestrian traffic control devices used to either close, redirect, divert or detour pedestrian traffic are Pedestrian Channelizing Devices and Audible Warning Devices

Construction Methods

The ADA compliant pedestrian traffic control devices involved in the closing or redirecting of pedestrians as designated on the Transportation Management Plan (TMP) shall be manufactured and assembled in accordance with the requirements of the Americans with Disabilities Act (ADA) and be on the NCDOT approved products list.

Pedestrian Channelizing Devices shall be manufactured and assembled to be connected as to eliminate any gaps that allow pedestrians to stray from the channelizing path. Any Pedestrian Channelizing Devices used to close or block a pedestrian facility shall have a "SIDEWALK CLOSED" sign affixed to it and any audible warning devices, if designated on the TMP.

Audible Warning Devices shall be manufactured to include a locator tone activated by a motion sensor and have the ability to program a message for a duration of at least 1 minute. The motion sensor shall have the ability to detect pedestrians a minimum of 10' away. The voice module may be automatic or it may be push button activated. If push button activated, it shall be mounted at a height of approximately 3.5 feet, but no more than 4 feet, above the pedestrian facility.

Measurement and Payment

Pedestrian Channelizing Devices will be measured and paid as the maximum number of linear feet of *Pedestrian Channelizing Devices* furnished, acceptably placed, and in use at any one time during the life of the project.

R-5799

TC-2

Transylvania County

No direct payment will be made for any sign affixed to a pedestrian channelizing device. Signs mounted to pedestrian channelizing devices will be considered incidental to the device.

Audible Warning Devices will be measured and paid as the maximum number of *Audible Warning Devices* furnished, acceptably installed, and in use at any one time during the life of the project.

Relocation, replacement, repair, maintenance, or disposal of *Pedestrian Channelizing Devices* and *Audible Warning Devices* will be incidental to the pay item.

Payment will be made under:

Pay Item	Pay Unit
Pedestrian Channelizing Devices	Linear Foot
Audible Warning Devices	Each

SEQUENTIAL FLASHING WARNING LIGHTS:

(10/08/2016)

Description

Furnish and install Sequential Flashing Warning Lights on drums used for merging tapers during nightly work activities on interstates and freeways with speed limits greater than 55 MPH and or facilities that have significant traffic volumes.

The purpose of these lights is to assist the motorist in determining which direction to merge when approaching a lane closure. It's also designed to reduce the number of late merges resulting in devices being struck and having to be reset to maintain positive guidance at the merge point. The successive flashing of the lights shall occur from the upstream end of the merging taper to the downstream end of the merging taper in order to identify the desired vehicle path.

Materials

The Sequential Flashing Warning Lights shall meet all of the requirements for warning lights within the current edition of the Manual of Uniform Traffic Control Devices (MUTCD).

Each light unit shall be capable of operating fully and continuously for a minimum of 200 hours when equipped with a standard battery set.

Each light in the sequence shall be flashed at a rate of not less than 55 times per minute and not more than 75 times per minute. The flash rate and flash duration shall be consistent throughout the sequence.

Supply a Type 3 Certification (Independent Test Lab results) documenting all actual test results for the specified parameters contained in the Institute of Transportation Engineer's (ITE's) *Purchase Specification for Flashing and Steady Burn Warning Lights*. The laboratory shall also identify all manufacturer codes and part numbers for the incandescent lamp or LED clusters, lenses, battery, and circuitry, and the total width of the light with the battery in place. The complete assembly shall be certified as crashworthy when firmly affixed to the channelizing device.

All Sequential Flashing Warning Lights shall be on the NCDOT Work Zone Traffic Control Approved Products List.

Construction Methods

Sequential Flashing Warning Lights are to be used for night time lane closures.

These lights shall flash sequentially beginning with the first light and continuing until the final light.

The Sequential Flashing Warning Lights shall automatically flash in sequence when placed on the drums that form the merging taper.

The number of lights used in the drum taper shall equal the number of drums used in the taper.

Drums are the only channelizing device allowed to mount sequential flashing warning lights.

The Sequential Flashing Warning Lights shall be weather independent and visual obstructions shall not interfere with the operation of the lights.

The Sequential Flashing Warning Lights shall automatically sequence when placed in line in an open area with a distance between lights of 10 to 100 feet. A 10 foot stagger in the line of lights shall have no adverse effect on the operation of the lights.

If one light fails, the flashing sequence shall continue. If more than 1 light fails, all of the lights are to be automatically turned to the "off" mode. Non-sequential flashing is prohibited.

When lane closures are not in effect, the Sequential Flashing Warning Lights shall be deactivated.

Measurement and Payment

Sequential Flashing Warning Lights will be measured and paid as the maximum number of sequential flashing warning lights satisfactorily installed and properly functioning at any one time during the life of the project.

This includes all materials and labor to install, maintain and remove all Sequential Flashing Warning Lights.

R-5799

TC-4

Transylvania County

Pay Item

Sequential Flashing Warning Lights

Pay Unit

Each

PROJECT SPECIAL PROVISIONS
Utility Construction

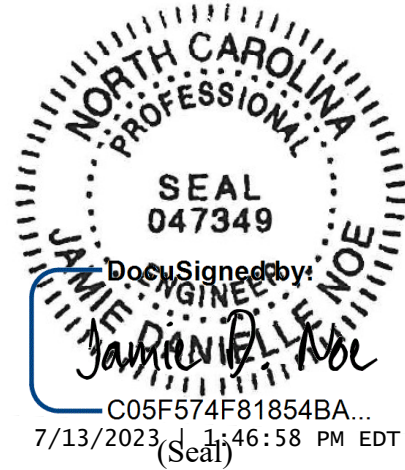

1318 Patton Avenue #F
Asheville, North Carolina 28806
Tel: (828)253-2796 / Fax: (828) 253-4864

DOCUMENT NOT CONSIDERED FINAL
UNLESS ALL SIGNATURES COMPLETED

Revise the 2018 Standard Specifications as follows:

Section 1034 – Sanitary Sewer Pipe Fittings

Following Section 1034-4 Ductile Iron Pipe, add the following:

1034-5 SEWER VALVES

(A) Gate Valves

Use iron body gate valves which conform to ANSI/AWWA C500 for bronze mounted, double disc, parallel seat type valves or to ANSI/AWWA C509 for resilient seat-type valves or to ANSI/AWWA C515 for reduced-wall, resilient seat gate valves. For buried service use gate valves with non-rising stems, 2-inch square operating nuts, O-ring seals and which open by turning counter clockwise. Gate valves shall have mechanical joint ends conforming to ANSI/AWWA C111/A21.11. Gate valves shall have a design working water pressure of 200 psi.

(B) Check Valves

Use iron body bronze mounted swing check valves conforming to AWWA C508 epoxy coated interior and exterior for corrosion resistance. Use valves with a design working pressure of 200 psi.

(C) Tapping Valves

Use tapping valves conforming to Subarticle 1036-7(A) with appropriately sized openings, with flanged by mechanical joint ends and pressure rated at 200 psi.

Section 1036- Water Pipe and Fittings**Page 10-63, Sub-article 1036-5 Ductile Iron Pipe and Fittings**

Add the following Sentence:

Gaskets located within 500 feet of underground gasoline storage shall be nitrile gaskets. All other gaskets shall be neoprene. All such work shall be considered incidental to the ductile iron pipe pay items included in the contract.

Page 10-63, Sub-article 1036-6 Fire Hydrants

Replace with the following sentence:

Use post type dry barrel fire hydrants with Storz connection and compression main valve conforming to ANSI/AWWA C502 standard with a 4 ½ inch main valve opening, one 4 ½” pumper nozzle and two 2 ½” hose nozzles with pressure class rating of 250 psi.

The bonnet shall be cast iron Class B conforming to ASTM A-126.

The pumper nozzle shall be bismuth brass alloy C89833 conforming to ASTM B-584, interchangeable, threaded in place and retained by stainless steel locks, with neoprene rubber cap gasket and a Buna N rubber O-ring conforming to ASTM D-2000.

The hose nozzle shall be bismuth brass alloy C89833 conforming to ASTM B-584, with neoprene rubber cap gasket and a Buna N rubber O-ring conforming to ASTM D-2000.

The nozzle caps shall be cast iron conforming to ASTM A-126, with rubber gasket and O-ring conforming to ASTM D-2000 attached with steel, non-kinking chains.

The upper barrel and lower barrel shall be cast iron Class B conforming to A-126.

The upper stem and lower stem shall be Grade 1144T carbon steel conforming to ASTM A-576, with alloy 122 copper sleeve.

The traffic flange shall be cast iron Class B conforming to A-126 with a Buna N rubber O-ring conforming to ASTM D-2000. The traffic stem coupling shall be stainless steel, 1.5% silicon max, conforming to A-890. The traffic flange hex cap screw shall be GR% galvanized Steel conforming to ASTM SAE J429.

The clevis pin and stem pin shall be 300 series stainless steel conforming to ASTM A-276. The Upper stem pin shall be 303 series stainless steel conforming to ASTM A-276.

The upper valve plate and seat ring shall be Alloy C89833 Bismuth Brass conforming to ASTM B-584.

The lower valve plate, drain ring housing and pipe gland shall be Class B cast iron conforming to ASTM A-126.

The shoe shall be 6-inch mechanical joint ductile iron complying with ANSI/AWWA C111/A.21.11-90 standard.

The hydrant shall be UL 246 listed, FM 1510 approved, complying with AWWA Standard C502 and UL Water Quality certified to ANSI/NSF 61/372.

Hydrant shall be backed by a 10-year warranty.

Hydrant shall be Mueller, Clow, American, or approved equal.

Division 15, Section 1500-General Utility Requirements

Page 15-1, Sub-article 1500-1 Description

Add the following sentences:

Construction of all water and sewer systems shall be in accordance with the NCDOT standards or the local jurisdictional standards whichever is more stringent and Special Provisions in effect at the time of bid.

City of Brevard contact Wesley Shook, Public Works Director, at (828) 884-2171 to obtain the current technical specification and a list of approved manufactures list.

Page 15-1, Sub-article 1500-2 Cooperation with the Utility Owner, paragraph 2:

Add the following sentences:

City of Brevard (COB) the contact person is Wesley Shook, Public Works Director, and can be reached by phone at (828) 884-2171 ext 4 Business Hours or (828) 883-2212 after hours.

All water and sewer lines are to remain active during construction of the project. To accomplish this the Contractor may elect to utilize bypass pumping, line stops, inserting valves, temporary water or other methods to complete the work. These methods and means of construction must be approved by the Engineer prior to commencement of the work and all such work shall be considered incidental to various other utility pay items included in the contract. All proposed water line and sewer line relocation work shall be performed at a time to be coordinated with the utility owner. Water lines or sewer lines shall not be taken out of service without prior approval of the utility owner and service interruptions shall not exceed four hours. Contractor shall not interfere or cover active water or sewer infrastructure including but not limited to water meters, water valves and sewer cleanouts.

Page 15-2, Sub-article 1500-6 Protection of Pedestrian and Vehicular Traffic, paragraph 1:

Add the following sentences:

While work is being performed in parking areas, measures shall be taken to minimize the time the parking area is closed.

Page 15-2, Sub-article 1500-7 SUBMITTALS AND RECORDS, paragraph 3:

Add the following sentences:

The City of Brevard shall be copied on contractor pay applications that include relevant utility items.

Any revisions to the utility plans shall be approved by the utility design engineer and reviewed and approved by the City prior to construction.

Partial and final engineering utility certifications should be provided to the design engineer prior to activation of services.

As-built plans and associated documentation shall be provided to the Engineer prior to acceptance of the work. A final inspection walk through with representation from the City, NCDOT, Contractor, and design engineer at completion of punch-list items is required before final acceptance.

As-built plans shall be provided to the City of Brevard showing the size and type of material installed and the coordinates of all utility horizontal and vertical locations of all installed piping and appurtenances. As-built drawings shall be signed, sealed and dated on each sheet by a North Carolina registered engineer (PE) as part of the City's acceptance process. As-Built Drawings shall be submitted and approved prior to issuance of final acceptance. All applicable information listed in the City's as-built drawing checklist shall be included.

Submit to the City's Engineering Department certified "Surveyed As-Built Drawings", including a .dxf and/or .dwg file and a PDF of the as-built construction drawings and a comma-delimited text file of the infrastructure and easement points with point descriptions (including point number, northing, easting, elevation, description).

Section 1505- Excavation, Trenching, Pipe Laying and Backfilling for Utilities**Page 15-4, Sub-article 1505-3 (E) Thrust Restraint for Ductile Iron Water Pipe Paragraph 3**

Add the following:

Thrust Collars shall be installed on water line pipe at all points recommended by the ENGINEER. Thrust collars shall be considered an integral part of the water line work. Work shall include a minimum of 3,000 psi concrete, reinforcement bars, threaded rod, retainer gland and anchor ring i.e. as shown in detail.

Page 15-5, Sub-article 1505-6 Measurement and Payment (D) Thrust Restraint:

Replace (D) Thrust Restraint with the following:

(D) Thrust Restraint and Collars,

Section 1510- Water Lines

Page 15-5, Sub-article 1510-2 Paragraph 3

Replace with the following:

Use 14 Gauge Type THNN solid copper tracer wire for the utility locator wires.

Page 15-6, Sub-article 1510-3(B) Testing and Sterilization:

Add the following:

If Contractor chooses to use a Line Stop, the City of Brevard reserves the right to flush, test and disinfect the new line.

After the pipeline has been satisfactorily constructed compete with the required fire hydrants, services, and all other appurtenances, and the trench backfilled satisfactorily, and after line flushing and approval by the Engineer, the newly constructed pipeline and valved sections shall be subjected to a hydrostatic pressure leakage test. The Contractor shall notify the Engineer when the work is ready for testing with all testing done in the presence of the Engineer. All labor, equipment, water and materials, including meters and gauges shall be furnished by the Contractor at his own expense.

Ductile iron pipe will be tested in accordance with AWWA C600.

Each completed section of the pipeline shall be plugged at both ends and slowly filled with water. As the main is being filed with water in preparation of the tests, all air shall be expelled from the pipe. The main shall be subjected to hydrostatic pressure of 200 pounds per square inch for a period of two (2) hours unless otherwise specified. Pressure shall be applied to the main by means of a hand pump for small lines or by use of a gasoline pump or fire engine for larger lines.

The rate of leakage shall be determined at fifteen (15) minute intervals by means of volumetric measurement of the water added during the test until the rate has stabilized at the constant value for three (3) consecutive fifteen (15) minute periods.

Leakage is defined as the quantity of water to be supplied into the newly laid pipe, or any valved section, necessary to maintain the specified leakage test pressure after the pipe has been filled with water and the air expelled. No piping installation will be accepted until the leakage is less than ten (10) gallons per inch of pipe diameter per mile of pipe per twenty-four (24) hours.

Cracked or defective pipe, joints, fittings, valves, or hydrants discovered in consequence of this test shall be removed and replaced with sound materials, and the test shall be repeated until the test results are satisfactory. Precautions shall be taken to remove or otherwise protect equipment in, or attached to, pipe to prevent damage or injury.

Pipe interiors, fittings, and valves shall be protected from contamination. Pipe delivered for construction shall be strung so as to minimize entrance of foreign matter. When pipe laying is not in progress for more than one hour, all openings in the pipeline shall be closed by watertight plugs. Joint of all pipe in the trench shall be completed before work is stopped. If water accumulates in the trench, the plug shall remain in place until the trench is dry.

If dirt enters the pipe that, in the opinion of the Engineer, will not be removed by flushing operations, the interior of the pipe shall be cleaned and swabbed as necessary, with a 5% hypochlorite disinfecting solution.

Sampling taps may be used as blow-offs. The number and locations of the taps/blow-offs must be approved by the Engineer. Hydrants may not be used for bacterial sampling.

The Contractor shall construct taps so that bacteriological samples can be easily collected without danger to personnel or likelihood of sample contamination. The Contractor shall legibly mark each sample tap with identifying letters or numbers for sample reference purposes. The Contractor shall not designate hydrants as taps for bacteriological sampling purposes. If the service or corporation taps are installed before the laboratory tests are completed, each tap will be tested for coliform bacterial.

Before being placed in service, all new mains and existing piping disturbed in any manner by the work shall be disinfected. Draining the water from existing piping or even lowering the water pressure more than one-half will constitute disturbance of the piping.

The disinfecting of water mains, valves and other appurtenances incorporated into the main construction shall be done by means of a chlorinating measuring apparatus, with proper devices for regulating the flow and providing an effective diffusion into the water within the main being disinfected by an application of chlorine-bearing compound bearing a high-test calcium hypochlorite (65-70% available chlorine). In the preparation of the solution, the powder shall first be made into a paste and then gradually thinned with water to approximately 1% chlorine solution (10,000 parts per pound of powder). This will require about 7.50 gallons of water to each one pound of powder. Solution shall be applied to the main through a rubber hose by gravity, siphonage, injection or by suitable pump feeder.

The point of chlorine application shall be at the beginning of the water main construction and/or any valve section thereof, through corporation cock installed close to and on the downstream side of the regulating gate valve controlling the flow of such proportion to the rate of water flow entering the main that the chlorine applied shall produce fifty (50) parts per million (420 pounds per million gallons) chlorine concentration in the water within the main.

During the disinfecting operation, valves, hydrants, and other mechanical devices controlling the flow of water shall be operated to permit full effectiveness of the chlorine. Valves shall be manipulated so that the strong solution within the main being sterilized will not flow back into the supply line nor flow into mains already in service. A chlorine concentration test shall be made, in turn, at each of the hydrants and/or taps provided for that purpose.

The tablet method of disinfection may be utilized for disinfection provided the total length of potable water main to be laid is less than 2,000 linear feet of pipe less than 12" in diameter. This method will be suitable only, if in the opinion of the Engineer, the pipeline has been maintained suitable free from foreign matter and any other contaminants during construction.

The Contractor shall provide sampling taps, Generally, sampling taps shall be provided on the water main every 1,000' and at the end of each main and at the end of each branch, in order to afford representative water testing and sample collection.

All disinfection shall be performed in accordance with AWWA Standard C651 and the Rules Governing Public Water Systems. All bacteriological tests shall be performed by a state-approved, certified laboratory per Rule .1001.

Section 1515- Utility Controls

Page 15-8, Sub-article 1515-3 Construction Methods

Add the following sentence:

Use HDPE or Copper with tracer wire (from main to meter box) for water service lines.

Page 15-10, 1515-4 Measure and Payment

Add the following Pay Item and Pay Unit:

Pay Item	Unit
_” Check Valve	Each

Section 1520- Sanitary Sewer

Page 15-10, Sub-article 1520-2 Paragraph 4

Replace with the following:

Use green coated No. 12 copper wire for the utility locator wires.

Page 15-10, Sub-article 1520-3(A) Gravity Sanitary Sewer:

Add the following sentences:

Sewer by-pass pump plan shall be submitted for the City’s approval with primary and backup pump specifications with telemetry to carry full flows of the sewer lines along with quick disconnect galvanized piping.

Air-testing will be conducted as the project is being installed. This includes all mainline between manholes, future mainline stubs and laterals out of manholes. The air testing shall be in accordance with ASTM F 1417.

CCTV all gravity sewer. All defects shall be corrected to the City's satisfaction prior to acceptance.

Deflection testing of all new PVC sewer pipe shall be conducted 30 days after installation and backfilling of the pipe or as otherwise directed by the Engineer.

The contractor shall furnish all necessary equipment including an approvable mandrel or other approved device and conduct the deflection tests at the direction of the Engineer.

The maximum allowable limits for deflection of installed pipe under this specification shall be 7.5%. Base inside diameters and 7.5% deflection mandrel dimensions shall be per ASTM F-679 (latest edition). Deflection shall be measured with a rigid mandrel (Go/No Go) device cylindrical in shape and constructed with a minimum of nine evenly spaced arms or prongs. Drawings of the mandrel with complete dimensions shall be submitted to the Engineer for each diameter of pipe to be tested. The mandrel shall be hand pulled through all sewer lines.

Any section of sewer not passing the mandrel shall be uncovered and the bedding and backfill replaced to prevent excessive deflection. Repaired pipe shall be retested to ensure that acceptable deflection limits are not exceeded.

The Contractor shall furnish and install during backfill operation for all gravity mainline sewers and laterals printed polyethylene green (SEWER) tape above the bedding material, three (3) feet above the crown of the pipe.

All testing of pipe and associated sewer manholes and appurtenances shall be considered incidental to the applicable pay items for gravity sanitary sewer pipe.

Section 1525- Utility Manholes

Page 15-14, Sub-article 1525-3(B) Installation of Precast Units:

Add the following sentences:

Doghouse manholes will be allowed on this project. They shall be placed on a minimum 6" pipe embedment material and minimum 6" concrete base.

Air Testing of all new manholes is required and shall meet the requirements of ASTM C1244. Manholes shall be sealed with plate-style sealing equipment on top of the casting so that the adjustment rings can also be tested. Bladder-style sealers are not acceptable. If a lateral is extended out of a manhole to a property the lateral shall be air tested with the manhole test, i.e. the lateral shall not be sealed off during the test.

All testing of manholes and appurtenances shall be considered incidental to the applicable pay items for utility manholes.

For all manholes installed within a concrete sidewalk, manhole covers shall be ADA compliant, slip-resistant type, with no pick hole.

Page 15-15, Sub-article 1525-3(D) Testing:

Add the following sentence:

Vacuum test all existing manholes with new connections before grouting and backfilling. Test according to ASTM C1244.

Page 15-17, Sub-article 1530-3(E) Remove Utilities

Add the following Sentence:

Remove the abandoned utilities in the area near the existing pump station on Sheet UC-4 and as noted on the plans.

END OF SECTION

Project: R-5799

US-1

County: Transylvania

PROJECT SPECIAL PROVISIONS**Utility Special****UTILITY COORDINATION:**

(03-23-23)

PSP15 R001

Description

The contractor shall provide an experienced Utility Coordinator to coordinate the physical utility relocations and protection of utility facilities during the construction phase of the project.

Definitions

Utility Construction (UC) – those construction activities that result in the proper installation of utilities that are to be performed by the prime contractor or his sub-contractors using the UC plans and UC special provisions under this contract.

Utilities by Others (UbO) - those construction activities that result in the proper installation of utilities that are to be performed by the others, such as municipal or private utility agency staff or contractors, using the UbO plans and UbO special provisions under this contract.

Utility Coordinator – personnel, provided by the prime contractor or his sub-contractor, who shall monitor all construction of utilities, all construction excavation activities within proximity to existing or newly installed utilities, promote communications between construction project parties, including but not limited to the Contractor's personnel, the utility owners' personnel, and the Department's personnel.

Coordinator Qualifications

The Contractor shall provide a Utility Coordinator who possesses one of the following levels of combined education and work experience:

College Degree	Work Experience
4-year (Bachelor's) ^A	5 years
2-year (Associate's) ^B	10 years
None	15 years
Or as approved by the Engineer	Or as approved by the Engineer

- A. 4-year degree shall be in one of the following disciplines: civil engineering, construction engineering, or construction project management.
- B. 2-year degree shall be in one of the following disciplines: civil engineering technology, construction engineering technology, construction project management, or surveying (geomatics) technology.

Project: R-5799

US-2

County: Transylvania

The Contractor shall provide documented proof that the Utility Coordinator is up to date on all required OSHA training for utilities construction. The Utility Coordinator shall be required to maintain all OSHA training certifications for the life of the project.

The Contractor shall submit these credentials to the Engineer for his or her approval no fewer than 30 days prior to the commencement of utility work on the project.

The Engineer, at his or her discretion, may require the Contractor to replace the Utility Coordinator. If this occurs, work in proximity of any utilities shall be suspended until an appropriate replacement has been made and approved by the Engineer. No claim for additional compensation or time shall be made for the replacement of the Utility Coordinator.

The Contractor shall not engage in utility work or other excavation work, near utilities until the Department has approved the credentials of the candidate for the Utility Coordinator position.

Coordinator Duties

The Contractor personnel, assigned as the Utility Coordinator, shall solely serve in the role and tasks described herein. This person shall be named and presented in writing at the Preconstruction Conference and cannot perform additional tasks on behalf of the Contractor that are beyond the scope of this provision for the duration of the project.

The Department coordinated previous utility relocation on this project in accordance with Article 105-8 of the 2018 Standard Specifications. The Department's utility coordination and design efforts stop at the dates shown on the Utility by Other and Utility Construction Special Provisions. The Utility Coordinator is tasked to continue the coordination efforts from where the Department left off in order to expedite the project schedule, while maintaining safety, and protecting existing utilities from damage.

The Utility Coordinator shall be present for all excavation activities near utilities, with excavation activities near existing gas lines taking precedence over other nearby utilities.

The Utility Coordinator shall be responsible for executing the following tasks:

(A) Initial Meetings:

- (1) Schedule and conduct an **Information Transfer Meeting** between all parties that have been involved with utility coordination prior to contract let, and all relevant parties that will be involved in contract administration.
 - a. Required Attendees: Assigned DOT Division Construction Personnel; Essential General Contractor Personnel; Assigned DOT Central Personnel (both in the Utilities and Project Management Units); the DOT contracted Utility Coordination Firm who handled Utility Coordination prior to contract let.

Project: R-5799

US-3

County: Transylvania

- b. Items To Be Discussed: Names and contact information for each utility owner on the project; All past communication with utility owners that is relevant as we continue; The most current update of where we are with each UbO/UC owner; Any other forthcoming issues that we need to be aware of as we proceed into construction.
 - c. Deliverables: A meeting agenda and meeting minutes for distribution.
- (2) Schedule and conduct a UbO/UC Scheduling Update Meeting including all UbO/UC Utility Owners. This meeting should be done after the Contractor has produced their proposed construction schedule.
- a. Required Attendees: Assigned DOT Division Construction Personnel, Needed General Contractor Personnel, Representatives of all Utility Owners who are identified in the UbO/UC Special Provisions.
 - b. Items To Be Discussed: Current relocation schedules of each UbO/UC Utility Owner; The proposed Contractor construction schedule; Identification of potential conflict points between the construction schedule and the utility schedules; Potential resolutions to these conflicts.
 - c. Deliverables: A meeting agenda, meeting minutes, UbO/UC schedule updates for distribution, list of action items to resolve scheduling conflicts.
- (3) Schedule and conduct a **Contract Utility Construction Meeting** including all Utility Owners whose facilities are being moved as part of the general roadway contract. This meeting needs to be conducted well in advance of the commencement of the Utility Construction contract work.
- a. Required Attendees: Assigned DOT Division Construction Personnel, Needed General Contractor Personnel, Representatives of all Utility Owners and their design engineers being relocated in the roadway contract, Assigned NCDOT Central Utilities Unit Personnel.
 - b. Items to be discussed: Contractor's projected schedule for Utility Owner's relocations; Utility Owner's expectations; Utility Owner construction inspection; All tie-ins and potential service disruptions; Utility Owner testing/sampling/flushing requirements.
 - c. Deliverables: A meeting agenda, meeting minutes, a Utility Construction schedule for each Utility Owner to take, a list of any action items that develop in the meeting.

Project: R-5799

US-4

County: Transylvania

(B) Utility Coordinator Tasks:**(1) UbO/UC Relocation Work**

- a. Observe and track UbO/UC relocation construction that occurs during the roadway contract time frame.
- b. Develop and maintain relationships with all UbO/UC Utility Owners and their utility relocation construction crews.
- c. Facilitate communication and scheduling between the multiple UbO/UC Utility Owners.
- d. Monitor UbO/UC relocation schedule progress to make sure the utility relocation schedule stays on track. Notify DOT Division Personnel if a scheduling problem is foreseen. Conduct meetings, etc. in order to address these scheduling issues on an as-needed basis.
- e. Check actual constructed locations of UbO/UC work to confirm it is out of the way of roadway construction.
- f. Ensure UbO/UC relocation companies are producing as-built drawings.

(2) Roadway Contract Work:

- a. Utility Damage Prevention
 - i. Identify all major utilities of note (gas, fiber optic cables, large diameter water, large diameter gravity sewer). Monitor excavations in these areas carefully.
 - ii. Keep one hard copy of NC811's positive response printout for every locate ticket called in on this contract in a notebook. If the ticket is called in by a subcontractor, the subcontractor must provide the Utility Coordinator with a hard copy of the positive response printout for safe keeping.
 - iii. Document all utility damage incidents with dates, notes, pictures, etc.

Attach the damage incident documentation to the corresponding NC811 locate ticket positive response printout.
 - iv. Report all utility damage incidents promptly and properly.
 - v. Work together with locators, excavators, and utility owners to mitigate the associated danger with a damaged utility. Focus on how to prevent these problems going forward.

Project: R-5799

US-5

County: Transylvania

- vi. Develop and maintain relationships with the NC811 contract locators, as well as the utility owners who locate their own utilities. Identify any utility which is not going to be located by a call to NC811. Make sure that utility owner gets notification of pending excavations.
- vii. Identify trends if utilities consistently get damaged, and work to alleviate the underlying problems to stop these trends.
- viii. Monitor all excavating crews/subcontractors and make sure they are practicing safe excavation around utilities.

b. Utility Construction Monitoring

- i. Supervise and monitor all Utility Construction work. Including associated traffic control.
- ii. Keep track of all contract utility pay items installed daily.
- iii. Keep utility owners up to date on the progress of their utility relocations.
- iv. For any interruptions in utility service for tie-ins, coordinate with the utility owner on their constraints for a service interruption (amount of down time, time of day that is best for shut down..etc.). Oversee the entire tie-in operation until it is complete.
- v. Develop a relationship with each utility owner to understand what that owner is looking for with their new utility installation. Make sure the utility owner is getting a final product that matches their expectations during installation.
- vi. Witness and coordinate all tests and procedures the utility owner (and/or regulations) require before that new utility line can be put in service. This could include: pressure testing, flushing, pigging, chlorinating, dechlorinating, tracing line wire testing, etc.
- vii. Facilitate the production of the utility owner's as-built drawings to make sure each utility owner gets accurate drawings as they require on their utility lines.

c. Handling Unknowns

- i. Proactively search for answers and get resolutions to conflicts that arise due to utilities found during excavation that have not been accounted for in the preconstruction utility coordination process.

Project: R-5799

US-6

County: Transylvania

- ii. Notify DOT Division Personnel of these issues ASAP.
- iii. Coordinate meetings, etc. in order to get resolutions to these problems.

d. Complaints

- i. Keep a log of all public complaints that arise due to the utility construction process or due to utility disruption from excavation.
- ii. Make the proper DOT Division Construction Personnel aware of any public complaints you hear directly from the public.
- iii. Proactively resolve these complaints and inform the proper DOT Division Personnel once a particular complaint is resolved.

(C) Monthly Required Utility Coordinator Reports and Meetings:

- a. **UbO/UC Monthly Report:** Provide Division Construction Personnel with a monthly report that includes:
 - iv. The UbO/UC relocation work accomplished that month broken down by individual utility.
 - v. The projected UbO/UC relocation work to be accomplished next month.
 - vi. Brief narrative on UbO/UC schedule and any other pertinent concerns that need to be addressed.
 - vii. Questions to answer in report: What's the most important action item on UbO/UC work right now? Does the Utility Coordinator need NCDOT help in getting action out of a UbO/UC utility company?
- e. **Utility Damage Prevention Monthly Report:** Provide Division Construction Personnel with a monthly report that includes:
 - i. All utility damage incidents for that month with documentation and narratives.
 - ii. Overall performance this month of excavators while digging around utilities.
 - iii. Activities going on other than excavation that can cause utility damage.
 - iv. Projected excavation areas that will be difficult next month.

Project: R-5799

US-7

County: Transylvania

- f. **Utility Construction Monthly Report:** Provide Division Construction Personnel with a monthly report that includes:
- i. The utility construction work accomplished that month broken down by Utility Owner.
 - ii. Projected Utility Construction work to be accomplished next month.
 - iii. Questions to answer in report: Any items of note coming up? Have you hit rock? Shutdowns or Tie-ins? Testing? Any complaints that need to be handled? Or unknown utilities encountered?
- g. Schedule and conduct a **Monthly Utility Meeting**. Distribute a meeting agenda with topics to be discussed to all attendees 3 days in advance so attendees have time to review agenda and comment.
- i. Required Attendees: Assigned DOT Division Construction Personnel, Needed General Contractor Personnel, Representatives of all Utility Owners who are identified in the UbO/UC Special Provisions, Representatives of all Utility Owners who are being relocated in the roadway contract, other parties as needed.
 - ii. Items To Be Discussed: Start meeting with a relevant “Safety Moment”; Last month’s progress; Projected progress last month versus actual progress; Next month’s projected progress; All issues concerning utilities: coordination, scheduling, unknowns. etc.; Leave the floor open for questions and concerns.
 - iii. Deliverables: a meeting agenda, meeting minutes with action items to be done by next meeting.

Measurement and Payment

Utility Coordination will be measured and paid for as the actual number of hours the utility coordinator spends, physically on the project site, performing the described duties for this project. Such price and payment will be full compensation for all work covered by this provision, including but not limited to communication, reports, meetings, and all incidentals necessary to complete the work. No payment will be made for work that is outside of this scope.

Before the initial payment request is submitted for approval under this pay item, all 3 Initial Meetings listed in this Special Provision must be completed.

Before the subsequent monthly pay requests are submitted for approval under this pay item, all 3 Monthly Reports must be completed, and the Monthly Utility Meeting held.

Project: R-5799

US-8

County: Transylvania

The Contractor shall submit a certified statement each month indicating the hours of work completed. The Engineer will determine if the amount indicated is reasonably correct and the Engineer will pay accordingly on the next partial pay estimate.

Payment will be made under:

Pay Item
Utility Coordination

Pay Unit
Hour



7/6/2023

PROJECT SPECIAL PROVISIONS

Utilities by Others



Vaughn & Melton
Consulting Engineers
1318 F. Patton Ave.
Asheville, North Carolina 28806
828-253-2796
www.vaughnmelton.com

General:

The following utility companies have facilities that are within the construction limits of this project:

- A) Duke Energy (Power Distribution and Transmission)
- B) Optimum (Morris Broadband) (Fiber Optic Communications)
- C) Comporium (Telephone and Cable TV)
- D) Dominion Energy (Natural Gas)
- E) AT&T (Fiber Optic Communications)

The conflicting facilities of these concerns will be adjusted prior to the date of availability, unless otherwise noted and are therefore listed in these special provisions for the benefit of the Contractor. All utility work listed herein for Duke, Comporium, AT&T, Dominion Energy and Optimum will be done by the utility owners. The water and sewer line construction will be a part of the roadway contract. All existing utilities are shown on the plans from the best available information.

The Contractor's attention is directed to Article 105-8 of the 2018 Standard Specifications.

Utilities Requiring Adjustment:

Utility Relocations are shown on the Utilities by Others (UO) Plans.

A) Duke Energy – Power (Distribution)

- 1) Duke Energy owns and maintains distribution facilities throughout the project corridor. They will relocate their distribution facilities, as shown on the UO plans, by the Date of Availability.
- 2) Contact person for Duke Energy Distribution is Mr. Bob Mabry at (828) 698-2055.

PROJECT SPECIAL PROVISIONS

Utilities by Others

B) Optimum (Morris Broadband) – Fiber Optic Communications

- 1) Optimum owns and maintains aerial facilities that are attached, by joint use agreement, to the Duke Energy poles. They will attach to the new poles placed by Duke Energy, by the Date of Availability.
- 2) Contact person for Optimum is Ms. Jennifer Jablonski at (828) 697-3600.

C) Comporium – Telephone, Fiber Optic and Cable TV

- 1) Comporium owns and maintains aerial and underground facilities throughout the project limits. Aerial facilities will be attached to the new joint use poles placed by Duke Energy and the relocation of the underground facilities in conflict with construction will be relocated as shown on the UO plans. Comporium will complete their work by the date of availability.
- 2) The contact person for Comporium is Mr. Jimmy Aldridge at (828) 883-6451.

D) Dominion Energy – Natural Gas

- 1) Dominion Energy owns and maintains existing gas throughout the project limits as shown on the UO plans.

The contractor will need to coordinate with Dominion Energy on (-Y1-) Ecusta Road during the construction of proposed CB 437 and the 30” RCP as shown on UO-4A. Dominion may need to relocate their existing 4” plastic gas line behind proposed CB 437. Dominion requires ten (10) days' notice by the Contractor to begin work and seven (7) days to complete the work.

The contractor will need to coordinate with Dominion Energy due to placement of fill along -Y2- Sta. 14+00 LT to -L- Sta. 32+00 RT prior to Dominion Energy installing their new 2” and 4” gas lines at this location as shown on Sheets UO-5 and UO-6. Dominion requires ten (10) days' notice by the Contractor to begin work and fourteen (14) days to complete the work.

Dominion Energy work will NOT be completed by the Date of Availability. Direct coordination between the contractor, the NCDOT, and Dominion Energy will be required during the construction of this project.

- 2) The contact person for Dominion Energy is Mr. Joe Lauffenburger at (612) 254-5324 and Mr. Greg Roberts at (828) 606-2701.

PROJECT SPECIAL PROVISIONS

Utilities by Others

E) AT&T

- 1) AT&T owns aerial facilities that are attached, by a joint use agreement, to the Duke Energy poles along the south side of -L- from the beginning of the project to Deavor Road. They also have aerial facilities on Duke poles along Deavor Road (-Y4-), that cross -L- to serve WalMart. AT&T will reattach to the new poles placed by Duke Energy, by the Date of Availability.
- 2) The contact person for is Mr. Lee Sadler (704) 478-7917.

**Project Special Provisions
Erosion Control**

STABILIZATION REQUIREMENTS:

(4-30-2019)

Stabilization for this project shall comply with the time frame guidelines as specified by the NCG-010000 general construction permit effective April 1, 2019 issued by the North Carolina Department of Environmental Quality Division of Water Resources. Temporary or permanent ground cover stabilization shall occur within 7 calendar days from the last land-disturbing activity, with the following exceptions in which temporary or permanent ground cover shall be provided in 14 calendar days from the last land-disturbing activity:

- Slopes between 2:1 and 3:1, with a slope length of 10 ft. or less
- Slopes 3:1 or flatter, with a slope of length of 50 ft. or less
- Slopes 4:1 or flatter

The stabilization timeframe for High Quality Water (HQW) Zones shall be 7 calendar days with no exceptions for slope grades or lengths. High Quality Water Zones (HQW) Zones are defined by North Carolina Administrative Code 15A NCAC 04A.0105 (25). Temporary and permanent ground cover stabilization shall be achieved in accordance with the provisions in this contract and as directed.

SEEDING AND MULCHING:

(WestEd)

The kinds of seed and fertilizer, and the rates of application of seed, fertilizer, and limestone, shall be as stated below. During periods of overlapping dates, the kind of seed to be used shall be determined. All rates are in pounds per acre.

Shoulder and Median Areas

August 1 - June 1

20#	Kentucky Bluegrass
75#	Hard Fescue
25#	Rye Grain
500#	Fertilizer
4000#	Limestone

May 1 - September 1

20#	Kentucky Bluegrass
75#	Hard Fescue
10#	German or Browntop Millet
500#	Fertilizer
4000#	Limestone

Areas Beyond the Mowing Pattern, Waste and Borrow Areas:

August 1 - June 1

100#	Tall Fescue
15#	Kentucky Bluegrass
30#	Hard Fescue
25#	Rye Grain
500#	Fertilizer
4000#	Limestone

May 1 - September 1

100#	Tall Fescue
15#	Kentucky Bluegrass
30#	Hard Fescue
10#	German or Browntop Millet
500#	Fertilizer
4000#	Limestone

Approved Tall Fescue Cultivars

06 Dust	Escalade	Justice	Serengeti
2 nd Millennium	Essential	Kalahari	Shelby
3 rd Millennium	Evergreen 2	Kitty Hawk 2000	Sheridan
Apache III	Falcon IV	Legitimate	Signia
Avenger	Falcon NG	Lexington	Silver Hawk
Barlexas	Falcon V	LSD	Sliverstar
Barlexas II	Faith	Magellan	Shenandoah Elite
Bar Fa	Fat Cat	Matador	Sidewinder
Barrera	Festnova	Millennium SRP	Skyline
Barrington	Fidelity	Monet	Solara
Barrobusto	Finelawn Elite	Mustang 4	Southern Choice II
Barvado	Finelawn Xpress	Ninja 2	Speedway
Biltmore	Finesse II	Ol' Glory	Spyder LS
Bingo	Firebird	Olympic Gold	Sunset Gold
Bizem	Firecracker LS	Padre	Taccoa
Blackwatch	Firenza	Patagonia	Tanzania
Blade Runner II	Five Point	Pedigree	Trio
Bonsai	Focus	Picasso	Tahoe II
Braveheart	Forte	Piedmont	Talladega
Bravo	Garrison	Plantation	Tarheel
Bullseye	Gazelle II	Proseeds 5301	Terrano
Cannavaro	Gold Medallion	Prospect	Titan ltd
Catalyst	Grande 3	Pure Gold	Titanium LS
Cayenne	Greenbrooks	Quest	Tracer
Cessane Rz	Greenkeeper	Raptor II	Traverse SRP
Chipper	Gremlin	Rebel Exeda	Tulsa Time
Cochise IV	Greystone	Rebel Sentry	Turbo
Constitution	Guardian 21	Rebel IV	Turbo RZ
Corgi	Guardian 41	Regiment II	Tuxedo RZ
Corona	Hemi	Regenerate	Ultimate
Coyote	Honky Tonk	Rendition	Venture
Darlington	Hot Rod	Rhambler 2 SRP	Umbrella
Davinci	Hunter	Rembrandt	Van Gogh
Desire	Inferno	Reunion	Watchdog
Dominion	Innovator	Riverside	Wolfpack II
Dynamic	Integrity	RNP	Xtremegreen
Dynasty	Jaguar 3	Rocket	
Endeavor	Jamboree	Scorpion	

Approved Kentucky Bluegrass Cultivars:

4-Season	Blue Velvet	Gladstone	Quantum Leap
Alexa II	Blueberry	Granite	Rambo
America	Boomerang	Hampton	Rhapsody
Apollo	Brilliant	Harmonie	Rhythm
Arcadia	Cabernet	Impact	Rita
Aries	Champagne	Jefferson	Royce
Armada	Champlain	Juliet	Rubicon
Arrow	Chicago II	Jump Start	Rugby II
Arrowhead	Corsair	Keeneland	Shiraz
Aura	Courtyard	Langara	Showcase
Avid	Delight	Liberator	Skye
Award	Diva	Madison	Solar Eclipse
Awesome	Dynamo	Mercury	Sonoma
Bandera	Eagleton	Midnight	Sorbonne
Barduke	Emblem	Midnight II	Starburst
Barnique	Empire	Moon Shadow	Sudden Impact
Baroness	Envicta	Moonlight SLT	Total Eclipse
Barrister	Everest	Mystere	Touche
Barvette HGT	Everglade	Nu Destiny	Tsunami
Bedazzled	Excursion	NuChicago	Unique
Belissimo	Freedom II	NuGlade	Valor
Bewitched	Freedom III	Odyssey	Voyager II
Beyond	Front Page	Perfection	Washington
Blacksburg II	Futurity	Pinot	Zinfandel
Blackstone	Gaelic	Princeton 105	
Blue Note	Ginney II	Prosperity	

Approved Hard Fescue Cultivars:

Aurora II	Eureka II	Oxford	Scaldis II
Aurora Gold	Firefly	Reliant II	Spartan II
Berkshire	Granite	Reliant IV	Stonehenge
Bighorn GT	Heron	Rescue 911	
Chariot	Nordic	Rhino	

On cut and fill slopes 2:1 or steeper add 20# Sericea Lespedeza and 15# Crown Vetch January 1 - December 31.

The Crown Vetch Seed should be double inoculated if applied with a hand seeder. Four times the normal rate of inoculant should be used if applied with a hydroseeder. If a fertilizer-seed slurry is used, the required limestone should also be included to prevent fertilizer acidity from killing the inoculant bacteria. Caution should be used to keep the inoculant below 80° F to prevent harm to the bacteria. The rates and grades of fertilizer and limestone shall be the same as specified for *Seeding and Mulching*.

Fertilizer shall be 10-20-20 analysis. A different analysis of fertilizer may be used provided the 1-2-2 ratio is maintained and the rate of application adjusted to provide the same amount of plant food as a 10-20-20 analysis and as directed.

Native Grass Seeding And Mulching

(West)

Native Grass Seeding and Mulching shall be performed on the disturbed areas of wetlands and riparian areas, and adjacent to Stream Relocation and/or trout stream construction within a 50 foot zone on both sides of the stream or depression, measured from top of stream bank or center of depression. The stream bank of the stream relocation shall be seeded by a method that does not alter the typical cross section of the stream bank. Native Grass Seeding and Mulching shall also be performed in the permanent soil reinforcement mat section of preformed scour holes, and in other areas as directed.

The kinds of seed and fertilizer, and the rates of application of seed, fertilizer, and limestone, shall be as stated below. During periods of overlapping dates, the kind of seed to be used shall be determined. All rates are in pounds per acre.

August 1 - June 1

18# Creeping Red Fescue
8# Big Bluestem
6# Indiangrass
4# Switchgrass
35# Rye Grain
500# Fertilizer
4000# Limestone

May 1 – September 1

18# Creeping Red Fescue
8# Big Bluestem
6# Indiangrass
4# Switchgrass
25# German or Browntop Millet
500# Fertilizer
4000# Limestone

Approved Creeping Red Fescue Cultivars:

Aberdeen

Boreal

Epic

Cindy Lou

Fertilizer shall be 10-20-20 analysis. A different analysis of fertilizer may be used provided the 1-2-2 ratio is maintained and the rate of application adjusted to provide the same amount of plant food as a 10-20-20 analysis and as directed.

Native Grass Seeding and Mulching shall be performed in accordance with Section 1660 of the *Standard Specifications* and vegetative cover sufficient to restrain erosion shall be installed immediately following grade establishment.

Measurement and Payment

Native Grass *Seeding and Mulching* will be measured and paid for in accordance with Article 1660-8 of the *Standard Specifications*.

TEMPORARY SEEDING:

Fertilizer shall be the same analysis as specified for *Seeding and Mulching* and applied at the rate of 400 pounds and seeded at the rate of 50 pounds per acre. German Millet, or Browntop Millet shall be used in summer months and rye grain during the remainder of the year. The Engineer will determine the exact dates for using each kind of seed.

FERTILIZER TOPDRESSING:

Fertilizer used for topdressing shall be 16-8-8 grade and shall be applied at the rate of 500 pounds per acre. A different analysis of fertilizer may be used provided the 2-1-1 ratio is maintained and the rate of application adjusted to provide the same amount of plant food as 16-8-8 analysis and as directed.

SUPPLEMENTAL SEEDING:

The kinds of seed and proportions shall be the same as specified for *Seeding and Mulching*, and the rate of application may vary from 25# to 75# per acre. The actual rate per acre will be determined prior to the time of topdressing and the Contractor will be notified in writing of the rate per acre, total quantity needed, and areas on which to apply the supplemental seed. Minimum tillage equipment, consisting of a sod seeder shall be used for incorporating seed into the soil as to prevent disturbance of existing vegetation. A clodbuster (ball and chain) may be used where degree of slope prevents the use of a sod seeder.

MOWING:

The minimum mowing height on this project shall be six inches.

LAWN TYPE APPEARANCE:

All areas adjacent to lawns must be hand finished as directed to give a lawn type appearance. Remove all trash, debris, and stones $\frac{3}{4}$ " and larger in diameter or other obstructions that could interfere with providing a smooth lawn type appearance. These areas shall be reseeded to match their original vegetative conditions, unless directed otherwise by the Field Operations Engineer.

REFORESTATION:**Description**

Reforestation will be planted within interchanges and along the outside borders of the road, and in other areas as directed. *Reforestation* is not shown on the plan sheets. See the Reforestation Detail Sheet.

All non-maintained riparian buffers impacted by the placement of temporary fill or clearing activities shall be restored to the preconstruction contours and revegetated with native woody species.

The entire *Reforestation* operation shall comply with the requirements of Section 1670 of the *Standard Specifications*.

Materials

Reforestation shall be bare root seedlings 12"-18" tall.

Construction Methods

Reforestation shall be planted as soon as practical following permanent *Seeding and Mulching*. The seedlings shall be planted in a 16-foot wide swath adjacent to mowing pattern line, or as directed.

Root dip: The roots of reforestation seedlings shall be coated with a slurry of water, and either a fine clay (kaolin) or a superabsorbent that is designated as a bare root dip. The type, mixture ratio, method of application, and the time of application shall be submitted to the Engineer for approval.

With the approval of the Engineer, seedlings may be coated before delivery to the job or at the time of planting, but at no time shall the roots of the seedlings be allowed to dry out. The roots shall be moistened immediately prior to planting.

Seasonal Limitations: *Reforestation* shall be planted from November 15 through March 15.

Measurement and Payment

Reforestation will be measured and paid for in accordance with Article 1670-17 of the *Standard Specifications*.

RESPONSE FOR EROSION CONTROL:

Description

Furnish the labor, materials, tools and equipment necessary to move personnel, equipment, and supplies to the project necessary for the pursuit of any or all of the following work as shown herein, by an approved subcontractor.

Section	Erosion Control Item	Unit
1605	Temporary Silt Fence	LF
1606	Special Sediment Control Fence	LF/TON
1615	Temporary Mulching	ACR
1620	Seed - Temporary Seeding	LB
1620	Fertilizer - Temporary Seeding	TN
1631	Matting for Erosion Control	SY

SP	Coir Fiber Mat	SY
1640	Coir Fiber Baffles	LF
SP	Permanent Soil Reinforcement Mat	SY
1660	Seeding and Mulching	ACR
1661	Seed - Repair Seeding	LB
1661	Fertilizer - Repair Seeding	TON
1662	Seed - Supplemental Seeding	LB
1665	Fertilizer Topdressing	TON
SP	Safety/Highly Visible Fencing	LF
SP	Response for Erosion Control	EA

Construction Methods

Provide an approved subcontractor who performs an erosion control action as described in the NPDES Inspection Form SPPP30. Each erosion control action may include one or more of the above work items.

Measurement and Payment

Response for Erosion Control will be measured and paid for by counting the actual number of times the subcontractor moves onto the project, including borrow and waste sites, and satisfactorily completes an erosion control action described in Form 1675. The provisions of Article 104-5 of the *Standard Specifications* will not apply to this item of work.

Payment will be made under:

Pay Item

Response for Erosion Control

Pay Unit

Each

ENVIRONMENTALLY SENSITIVE AREAS:

Description

This project is located in an *Environmentally Sensitive Area*. This designation requires special procedures to be used for clearing and grubbing, temporary stream crossings, and grading operations within the Environmentally Sensitive Areas identified on the plans and as designated by the Engineer. This also requires special procedures to be used for seeding and mulching and staged seeding within the project.

The Environmentally Sensitive Area shall be defined as a 50-foot buffer zone on both sides of the stream or depression measured from top of streambank or center of depression.

Construction Methods

(A) Clearing and Grubbing

In areas identified as Environmentally Sensitive Areas, the Contractor may perform clearing operations, but not grubbing operations until immediately prior to beginning grading operations as described in Article 200-1 of the *Standard Specifications*. Only clearing operations (not grubbing) shall be allowed in this buffer zone until immediately prior to beginning grading operations. Erosion control devices shall be installed immediately following the clearing operation.

(B) Grading

Once grading operations begin in identified Environmentally Sensitive Areas, work shall progress in a continuous manner until complete. All construction within these areas shall progress in a continuous manner such that each phase is complete and areas are permanently stabilized prior to beginning of next phase. Failure on the part of the Contractor to complete any phase of construction in a continuous manner in Environmentally Sensitive Areas will be just cause for the Engineer to direct the suspension of work in accordance with Article 108-7 of the *Standard Specifications*.

(C) Temporary Stream Crossings

Any crossing of streams within the limits of this project shall be accomplished in accordance with the requirements of Subarticle 107-12 of the *Standard Specifications*.

(D) Seeding and Mulching

Seeding and mulching shall be performed in accordance with Section 1660 of the *Standard Specifications* and vegetative cover sufficient to restrain erosion shall be installed immediately following grade establishment.

Seeding and mulching shall be performed on the areas disturbed by construction immediately following final grade establishment. No appreciable time shall lapse into the contract time without stabilization of slopes, ditches and other areas within the Environmentally Sensitive Areas.

(E) Stage Seeding

The work covered by this section shall consist of the establishment of a vegetative cover on cut and fill slopes as grading progresses. Seeding and mulching shall be done in stages on cut and fill slopes that are greater than 20 feet in height measured along the slope, or greater than 2 acres in area. Each stage shall not exceed the limits stated above.

Additional payments will not be made for the requirements of this section, as the cost for this work shall be included in the contract unit prices for the work involved.

MINIMIZE REMOVAL OF VEGETATION:

The Contractor shall minimize removal of vegetation within project limits to the maximum extent practicable. Vegetation along stream banks and adjacent to other jurisdictional resources outside the construction limits shall only be removed upon approval of Engineer. No additional payment will be made for this minimization work.

STOCKPILE AREAS:

The Contractor shall install and maintain erosion control devices sufficient to contain sediment around any erodible material stockpile areas as directed.

ACCESS AND HAUL ROADS:

At the end of each working day, the Contractor shall install or re-establish temporary diversions or earth berms across access/haul roads to direct runoff into sediment devices. Silt fence sections that are temporarily removed shall be reinstalled across access/haul roads at the end of each working day.

CONSTRUCTION MATERIALS MANAGEMENT

(3-19-19) (rev. 04-27-20)

Description

The requirements set forth shall be adhered to in order to meet the applicable materials handling requirements of the NCG010000 permit. Structural controls installed to manage construction materials stored or used on site shall be shown on the E&SC Plan. Requirements for handling materials on construction sites shall be as follows:

Polyacrylamides (PAMS) and Flocculants

Polyacrylamides (PAMS) and flocculants shall be stored in leak-proof containers that are kept under storm-resistant cover or surrounded by secondary containment structures designed to protect adjacent surface waters. PAMS or other flocculants used shall be selected from the NC DWR List of Approved PAMS/Flocculants. The concentration of PAMS and other flocculants used shall not exceed those specified in the NC DWR List of Approved PAMS/Flocculants and in accordance with the manufacturer's instructions. The NC DWR List of Approved PAMS/Flocculants is available at:

https://files.nc.gov/ncdeq/Water+Quality/Environmental+Sciences/ATU/PAM8_30_18.pdf

Equipment Fluids

Fuels, lubricants, coolants, and hydraulic fluids, and other petroleum products shall be handled and disposed of in a manner so as not to enter surface or ground waters and in accordance with applicable state and federal regulations. Equipment used on the site must be operated and

maintained properly to prevent discharge of fluids. Equipment, vehicle, and other wash waters shall not be discharged into E&SC basins or other E&SC devices. Alternative controls should be provided such that there is no discharge of soaps, solvents, or detergents.

Waste Materials

Construction materials and land clearing waste shall be disposed of in accordance with North Carolina General Statutes, Chapter 130A, Article 9 - Solid Waste Management, and rules governing the disposal of solid waste (15A NCAC 13B). Areas dedicated for managing construction material and land clearing waste shall be at least 50 feet away from storm drain inlets and surface waters unless it can be shown that no other alternatives are reasonably available. Paint and other liquid construction material waste shall not be dumped into storm drains. Paint and other liquid construction waste washouts should be located at least 50 feet away from storm drain inlets unless there is no alternative. Other options are to install lined washouts or use portable, removable bags or bins. Hazardous or toxic waste shall be managed in accordance with the federal Resource Conservation and Recovery Act (RCRA) and NC Hazardous Waste Rules at 15A NCAC, Subchapter 13A. Litter and sanitary waste shall be managed in a manner to prevent it from entering jurisdictional waters and shall be disposed of offsite.

Herbicide, Pesticide, and Rodenticides

Herbicide, pesticide, and rodenticides shall be stored and applied in accordance with the Federal Insecticide, Fungicide, and Rodenticide Act, North Carolina Pesticide Law of 1971 and labeling restrictions.

Concrete Materials

Concrete materials onsite, including excess concrete, must be controlled and managed to avoid contact with surface waters, wetlands or buffers. No concrete or cement slurry shall be discharged from the site. (Note that discharges from onsite concrete plants require coverage under a separate NPDES permit – NCG140000.) Concrete wash water shall be managed in accordance with the *Concrete Washout Structure* provision. Concrete slurry shall be managed and disposed of in accordance with *NCDOT DGS and HOS DCAR Distribution of Class A Residuals Statewide* (Permit No. WQ0035749). Any hardened concrete residue will be disposed of, or recycled on site, in accordance with state solid waste regulations.

Earthen Material Stock Piles

Earthen material stock piles shall be located at least 50 feet away from storm drain inlets and surface waters unless it can be shown that no other alternatives are reasonably available.

Measurement and Payment

Conditions set within the *Construction Materials Management* provision are incidental to the project for which no direct compensation will be made.

WASTE AND BORROW SOURCES:

(2-16-11) (Rev. 3-17-22)

Payment for temporary erosion control measures, except those made necessary by the Contractor's own negligence or for his own convenience, will be paid for at the appropriate contract unit price for the devices or measures utilized in borrow sources and waste areas.

No additional payment will be made for erosion control devices or permanent seeding and mulching in any commercial borrow or waste pit. All erosion and sediment control practices that may be required on a commercial borrow or waste site will be done at the Contractor's expense.

All offsite Staging Areas, Borrow and Waste sites shall be in accordance with "Borrow and Waste Site Reclamation Procedures for Contracted Projects" located at:

<https://connect.ncdot.gov/resources/roadside/FieldOperationsDocuments/Contract%20Reclamation%20Procedures.pdf>

All forms and documents referenced in the "Borrow and Waste Site Reclamation Procedures for Contracted Projects" shall be included with the reclamation plans for offsite staging areas, and borrow and waste sites.

SAFETY FENCE AND JURISDICTIONAL FLAGGING:**Description**

Safety Fence shall consist of furnishing materials, installing and maintaining polyethylene or polypropylene fence along the outside riparian buffer, wetland, or water boundary, or other boundaries located within the construction corridor to mark the areas that have been approved to infringe within the buffer, wetland, endangered vegetation, culturally sensitive areas or water. The fence shall be installed prior to any land disturbing activities.

Interior boundaries for jurisdictional areas noted above shall be delineated by stakes and highly visible flagging.

Jurisdictional boundaries at staging areas, waste sites, or borrow pits, whether considered outside or interior boundaries shall be delineated by stakes and highly visible flagging.

Materials**(A) Safety Fencing**

Polyethylene or polypropylene fence shall be a highly visible preconstructed safety fence approved by the Engineer. The fence material shall have an ultraviolet coating.

Either wood posts or steel posts may be used. Wood posts shall be hardwood with a wedge or pencil tip at one end, and shall be at least 5 ft. in length with a minimum nominal 2" x 2" cross

section. Steel posts shall be at least 5 ft. in length, and have a minimum weight of 0.85 lb/ft of length.

(B) Boundary Flagging

Wooden stakes shall be 4 feet in length with a minimum nominal 3/4" x 1-3/4" cross section. The flagging shall be at least 1" in width. The flagging material shall be vinyl and shall be orange in color and highly visible.

Construction Methods

No additional clearing and grubbing is anticipated for the installation of this fence. The fence shall be erected to conform to the general contour of the ground.

(A) Safety Fencing

Posts shall be set at a maximum spacing of 10 ft., maintained in a vertical position and hand set or set with a post driver. Posts shall be installed a minimum of 2 ft. into the ground. If hand set, all backfill material shall be thoroughly tamped. Wood posts may be sharpened to a dull point if power driven. Posts damaged by power driving shall be removed and replaced prior to final acceptance. The tops of all wood posts shall be cut at a 30-degree angle. The wood posts may, at the option of the Contractor, be cut at this angle either before or after the posts are erected.

The fence geotextile shall be attached to the wood posts with one 2" galvanized wire staple across each cable or to the steel posts with wire or other acceptable means.

Place construction stakes to establish the location of the safety fence in accordance with Article 105-9 or Article 801-1 of the *Standard Specifications*. No direct pay will be made for the staking of the safety fence. All stakeouts for safety fence shall be considered incidental to the work being paid for as "Construction Surveying", except that where there is no pay item for construction surveying, all safety fence stakeout will be performed by state forces.

The Contractor shall be required to maintain the safety fence in a satisfactory condition for the duration of the project as determined by the Engineer.

(B) Boundary Flagging

Boundary flagging delineation of interior boundaries shall consist of wooden stakes on 25 feet maximum intervals with highly visible orange flagging attached. Stakes shall be installed a minimum of 6" into the ground. Interior boundaries may be staked on a tangent that runs parallel to buffer but must not encroach on the buffer at any location. Interior boundaries of hand clearing shall be identified with a different colored flagging to distinguish it from mechanized clearing.

Boundary flagging delineation of interior boundaries will be placed in accordance with Article 105-9 or Article 801-1 of the *Standard Specifications*. No direct pay will be made for delineation of the interior boundaries. This delineation will be considered incidental to the work being paid

for as *Construction Surveying*, except that where there is no pay item or construction surveying the cost of boundary flagging delineation shall be included in the unit prices bid for the various items in the contract. Installation for delineation of all jurisdictional boundaries at staging areas, waste sites, or borrow pits shall consist of wooden stakes on 25 feet maximum intervals with highly visible orange flagging attached. Stakes shall be installed a minimum of 6" into the ground. Additional flagging may be placed on overhanging vegetation to enhance visibility but does not substitute for installation of stakes.

Installation of boundary flagging for delineation of all jurisdictional boundaries at staging areas, waste sites, or borrow pits shall be performed in accordance with Subarticle 230-4(B)(5) or Subarticle 802-2(F) of the *Standard Specifications*. No direct pay will be made for this delineation, as the cost of same shall be included in the unit prices bid for the various items in the contract.

The Contractor shall be required to maintain alternative stakes and highly visible flagging in a satisfactory condition for the duration of the project as determined by the Engineer.

Measurement and Payment

Safety Fence will be measured and paid as the actual number of linear feet of polyethylene or polypropylene fence installed in place and accepted. Such payment will be full compensation including but not limited to furnishing and installing fence geotextile with necessary posts and post bracing, staples, tie wires, tools, equipment and incidentals necessary to complete this work.

Payment will be made under:

Pay Item	Pay Unit
Safety Fence	Linear Foot

COIR FIBER WATTLES WITH POLYACRYLAMIDE (PAM):

Description

Coir Fiber Wattles are tubular products consisting of coir fibers (coconut fibers) encased in coir fiber netting. Coir Fiber Wattles are used on slopes or channels to intercept runoff and act as a velocity break. Coir Fiber Wattles are to be placed at locations shown on the plans or as directed. Installation shall follow the detail provided in the plans and as directed. Work includes furnishing materials, installation of coir fiber wattles, matting installation, PAM application, and removing wattles.

Materials

Coir Fiber Wattle shall meet the following specifications:

100% Coir (Coconut) Fibers	
Minimum Diameter	12 in.
Minimum Density	3.5 lb/ft ³ +/- 10%

Net Material	Coir Fiber
Net Openings	2 in. x 2 in.
Net Strength	90 lbs.
Minimum Weight	2.6 lbs./ft. +/- 10%

Anchors: Stakes shall be used as anchors.

Wooden Stakes:

Provide hardwood stakes a minimum of 2-ft. long with a 2 in. x 2 in. nominal square cross section. One end of the stake must be sharpened or beveled to facilitate driving down into the underlying soil.

Matting shall meet the requirements of Article 1060-8 of the *Standard Specifications*, or shall meet specifications provided elsewhere in this contract.

Provide staples made of 0.125" diameter new steel wire formed into a *u* shape not less than 12" in length with a throat of 1" in width.

Polyacrylamide (PAM) shall be applied in powder form and shall be anionic or neutrally charged. Soil samples shall be obtained in areas where the wattles will be placed, and from offsite material used to construct the roadway, and analyzed for the appropriate PAM flocculant to be utilized with each wattle. The PAM product used shall be listed on the North Carolina Department of Environmental Quality Division of Water Resources web site as an approved PAM product for use in North Carolina.

Construction Methods

Coir Fiber Wattles shall be secured to the soil by wire staples approximately every 1 linear foot and at the end of each section of wattle. A minimum of 4 stakes shall be installed on the downstream side of the wattle with a maximum spacing of 2 linear feet along the wattle, and according to the detail. Install a minimum of 2 stakes on the upstream side of the wattle according to the detail provided in the plans. Stakes shall be driven into the ground a minimum of 10 in. with no more than 2 in. projecting from the top of the wattle. Drive stakes at an angle according to the detail provided in the plans.

Only install coir fiber wattle(s) to a height in ditch so flow will not wash around wattle and scour ditch slopes and according to the detail provided in the plans and as directed. Overlap adjoining sections of wattles a minimum of 6 in.

Installation of matting shall be in accordance with the detail provided in the plans, and in accordance with Article 1631-3 of the *Standard Specifications*, or in accordance with specifications provided elsewhere in this contract.

Apply PAM over the lower center portion of the coir fiber wattle where the water is going to flow over at a rate of 2 ounces per wattle, and 1 ounce of PAM on matting on each side of the wattle.

PAM applications shall be done during construction activities after every rainfall event that is equal to or exceeds 0.50 in.

The Contractor shall maintain the coir fiber wattles until the project is accepted or until the wattles are removed, and shall remove and dispose of silt accumulations at the wattles when so directed in accordance with the requirements of Section 1630 of the *Standard Specifications*.

Measurement and Payment

Coir Fiber Wattles will be measured and paid for by the actual number of linear feet of wattles which are installed and accepted. Such price and payment will be full compensation for all work covered by this section, including, but not limited to, furnishing all materials, labor, equipment and incidentals necessary to install the *Coir Fiber Wattles*.

Matting will be measured and paid for in accordance with Article 1631-4 of the *Standard Specifications*, or in accordance with specifications provided elsewhere in this contract.

Polyacrylamide(PAM) will be measured and paid for by the actual weight in pounds of PAM applied to the coir fiber wattles. Such price and payment will be full compensation for all work covered by this section, including, but not limited to, furnishing all materials, labor, equipment and incidentals necessary to apply the *Polyacrylamide(PAM)*.

Payment will be made under:

Pay Item	Pay Unit
Polyacrylamide(PAM)	Pound
Coir Fiber Wattle	Linear Foot

TEMPORARY ROCK SILT CHECK TYPE A WITH EXCELSIOR MATTING AND POLYACRYLAMIDE (PAM):

Description

Temporary Rock Silt Checks Type A with Excelsior Matting and Polyacrylamide (PAM) are devices utilized in temporary and permanent ditches to reduce runoff velocity and incorporate PAM into the construction runoff to increase settling of sediment particles and reduce turbidity of runoff. Temporary Rock Silt Checks Type A with Excelsior Matting and PAM are to be placed at locations shown on the plans or as directed. Installation shall follow the detail provided in the plans and as directed. Work includes furnishing materials, installation of Temporary Rock Silt Checks Type A, matting installation, PAM application, and removing Temporary Rock Silt Checks Type A with Excelsior Matting and PAM.

Materials

Structural stone shall be class B stone that meets the requirements of Section 1042 of the *Standard Specifications* for Stone for Erosion Control, Class B.

Sediment control stone shall be #5 or #57 stone, which meets the requirements of Section 1005 of the *Standard Specifications* for these stone sizes.

Matting shall meet the requirements of Excelsior Matting in Subarticle 1060-8(B) of the *Standard Specifications*, or shall meet specifications provided elsewhere in this contract.

Polyacrylamide (PAM) shall be applied in powder form and shall be anionic or neutrally charged. Soil samples shall be obtained in areas where the Temporary Rock Silt Checks Type A with Excelsior Matting and PAM will be placed, and from offsite material used to construct the roadway, and analyzed for the appropriate PAM flocculant to be utilized with each Temporary Rock Silt Check Type A. The PAM product used shall be listed on the North Carolina Department of Environmental Quality Division of Water Resources web site as an approved PAM product for use in North Carolina.

Construction Methods

Temporary Rock Silt Checks Type A shall be installed in accordance with Subarticle 1633-3(A) of the *Standard Specifications*, Roadway Standard Drawing No. 1633.01 and the detail provided in the plans.

Installation of matting shall be in accordance with the detail provided in the plans, and anchored by placing Class B stone on top of the matting at the upper and lower ends.

Apply PAM at a rate of 4 ounces over the center portion of the Temporary Rock Silt Checks Type A and matting where the water is going to flow over. PAM applications shall be done during construction activities and after every rainfall event that is equal to or exceeds 0.50 in.

The Contractor shall maintain the Temporary Rock Silt Checks Type A with Excelsior Matting and PAM until the project is accepted or until the Temporary Rock Silt Checks Type A with Excelsior Matting and PAM are removed, and shall remove and dispose of silt accumulations at the Temporary Rock Silt Checks Type A with Excelsior Matting and PAM when so directed in accordance with the requirements of Section 1630 of the *Standard Specifications*.

Measurement and Payment

Temporary Rock Silt Checks Type A will be measured and paid for in accordance with Article 1633-5 of the *Standard Specifications*, or in accordance with specifications provided elsewhere in this contract.

Matting will be measured and paid for in accordance with Article 1631-4 of the *Standard Specifications*, or in accordance with specifications provided elsewhere in this contract.

Polyacrylamide(PAM) will be measured and paid for by the actual weight in pounds of PAM applied to the Temporary Rock Silt Checks Type A. Such price and payment will be full compensation for all work covered by this section, including, but not limited to, furnishing all materials, labor, equipment and incidentals necessary to apply the *Polyacrylamide(PAM)*.

Payment will be made under:

Pay Item

Polyacrylamide(PAM)

Pay Unit

Pound

IMPERVIOUS DIKE:

(9-9-11)(Rev. 11-15-22)

Description

This work consists of furnishing, installing, maintaining, pumping and removing an *Impervious Dike* for the purpose of diverting normal stream flow around the construction site. The Contractor shall construct an impervious dike in such a manner approved by the Engineer. The impervious dike shall not permit seepage of water into the construction site or contribute to siltation of the stream. The impervious dike shall be constructed of an acceptable material in the locations noted on the plans or as directed by the Engineer.

Materials

Acceptable materials shall include but not be limited to sheet piles, sandbags, and/or the placement of an acceptable size stone lined with polypropylene or other impervious geotextile.

Earth material shall not be used to construct an impervious dike when it is in direct contact with the stream unless vegetation can be established before contact with the stream takes place.

Construction Methods

Where impervious dikes are shown on the plans and used to dewater or lower the water elevation, construct in accordance with Article 410-4 and 410-5.

Measurement and Payment

Impervious Dike will be measured and paid as the actual number of linear feet of impervious dike(s) constructed, measured in place from end to end of each separate installation that has been completed and accepted by the Engineer. Such price and payment will be full compensation for all work including but not limited to furnishing materials, construction, maintenance, pumping and removal of the impervious dike.

Payment will be made under:

Pay Item

Impervious Dike

Pay Unit

Linear Foot

PUMP AROUND OPERATION:**Description**

The work covered by this section consists of furnishing, installing, maintaining and removing any and all pump around systems used on this project. The Contractor shall install a pump around system in locations as shown in the plans and in other locations approved by the Engineer. The pump around system shall provide a passageway for the stream flow around the work site.

The quantity of pump around systems may be increased, decreased, or eliminated entirely as directed. Such variations in quantity will not be considered as alterations in the details of construction or a change in the character of the work. See NCDOT *Best Management Practices for Construction and Maintenance Activities* manual for example pump around operation.

Materials

Item	Section
Special Stilling Basin	1639

Impervious Dike shall meet the specifications as provided elsewhere in this contract.

Pumps shall be of sufficient size to divert the stream flow around the work area, as approved by the Engineer.

Construction Methods

Install *impervious dike(s)* as shown on the plans or as directed. Pump water around the work site. If the water is turbid or exposed to bare soil, pump through a *special stilling basin*. Once the work is complete in an area remove the *impervious dike(s)* and pump system, and stabilize the area.

Measurement and Payment

Impervious Dike will be measured and paid for as provided elsewhere in this contract.

Special Stilling Basin will be measured and paid for in accordance with Article 1639-4 of the *Standard Specifications*.

Payment for pumping operations shall be considered incidental to the work of installing pipes and culverts. The pumping operations shall include but not be limited to, diverting the stream flow around the work area and pumping runoff from the work area into a stilling basin, special stilling basin or other sediment control device. No additional payment will be made for furnishing materials or maintenance of the pumping operations for the installation of pipes and culverts.

The above prices and payments will be full compensation for all work covered by this section including, but not limited to furnishing all of the necessary materials, construction, maintenance and removal of the impervious dike and pump around system.

COIR FIBER MAT:**Description**

Furnish material, install and maintain coir fiber mat in locations shown on the plans or in locations as directed. Work includes providing all materials, excavating and backfilling, and placing and securing coir fiber mat with stakes, steel reinforcement bars or staples as directed.

Materials

Item	Section
Coir Fiber Mat	1060-14

Anchors: Stakes, reinforcement bars, or staples shall be used as anchors.

Wooden Stakes:

Provide hardwood stakes 12"- 24" long with a 2" x 2" nominal square cross section. One end of the stake must be sharpened or beveled to facilitate driving through the coir fiber mat and down into the underlying soil. The other end of the stake needs to have a 1"- 2" long head at the top with a 1"- 2" notch following to catch and secure the coir fiber mat.

Steel Reinforcement Bars:

Provide uncoated #10 steel reinforcement bars 24" nominal length. The bars shall have a 4" diameter bend at one end with a 4" straight section at the tip to catch and secure the coir fiber mat.

Staples:

Provide staples made of 0.125" diameter new steel wire formed into a *u* shape not less than 12" in length with a throat of 1" in width.

Construction Methods

Place the coir fiber mat immediately upon final grading. Provide a smooth soil surface free from stones, clods, or debris that will prevent the contact of the mat with the soil. Unroll the mat and apply without stretching such that it will lie smoothly but loosely on the soil surface.

For stream relocation applications, take care to preserve the required line, grade, and cross section of the area covered. Bury the top slope end of each piece of mat in a narrow trench at least 6 in. deep and tamp firmly. Where one roll of matting ends and a second roll begins, overlap the end of the upper roll over the buried end of the second roll so there is a 6 in. overlap. Construct check trenches at least 12 in. deep every 50 ft. longitudinally along the edges of the mat or as directed. Fold over and bury mat to the full depth of the trench, close and tamp firmly. Overlap mat at least 6 in. where 2 or more widths of mat are installed side by side.

Place anchors across the mat at the ends approximately 1 ft. apart. Place anchors along the outer edges and down the center of the mat 3 ft. apart.

Adjustments in the trenching or anchoring requirements to fit individual site conditions may be required.

Measurement and Payment

Coir Fiber Mat will be measured and paid for as the actual number of square yards measured along the surface of the ground over which coir fiber mat is installed and accepted.

No measurement will be made for anchor items.

Payment will be made under:

Pay Item	Pay Unit
Coir Fiber Mat	Square Yard

CONCRETE WASHOUT STRUCTURE:

(12-10-20)

Description

Concrete washout structures are enclosures above or below grade to contain concrete waste water and associated concrete mix from washing out ready-mix trucks, drums, pumps, or other equipment. Concrete washouts must collect and retain all the concrete washout water and solids, so that this material does not migrate to surface waters or into the ground water. These enclosures are not intended for concrete waste not associated with wash out operations.

The concrete washout structure may include constructed devices above or below ground and or commercially available devices designed specifically to capture concrete wash water.

Materials

Item	Section
Temporary Silt Fence	1605

Safety Fence shall meet the specifications as provided elsewhere in this contract.

Geomembrane basin liner shall meet the following minimum physical properties for low permeability; it shall consist of a polypropylene or polyethylene 10 mil thick geomembrane. If the minimum setback dimensions can be achieved the liner is not required. (5 feet above groundwater, 50 feet from top of bank of perennial stream, other surface water body, or wetland.)

Construction Methods

Build an enclosed earthen berm or excavate to form an enclosure in accordance with the details and as directed.

Install temporary silt fence around the perimeter of the enclosure in accordance with the details and as directed if structure is not located in an area where existing erosion and sedimentation control devices are capable to containing any loss of sediment.

Post a sign with the words “Concrete Washout” in close proximity of the concrete washout area, so it is clearly visible to site personnel. Install safety fence as directed for visibility to construction traffic.

The construction details for the above grade and below grade concrete washout structures can be found on the following web page link:

<https://connect.ncdot.gov/resources/roadside/SoilWaterDocuments/ConcreteWashoutStructuredetail.pdf>

Alternate details for accommodating concrete washout may be submitted for review and approval.

The alternate details shall include the method used to retain and dispose of the concrete waste water within the project limits and in accordance with the minimum setback requirements. (5 feet above groundwater, 50 feet from top of bank of perennial stream, other surface water body, or wetland.)

Maintenance and Removal

Maintain the concrete washout structure(s) to provide adequate holding capacity plus a minimum freeboard of 12 inches. Remove and dispose of hardened concrete and return the structure to a functional condition after reaching 75% capacity.

Inspect concrete washout structures for damage and maintain for effectiveness.

Remove the concrete washout structures and sign upon project completion. Grade the earth material to match the existing contours and permanently seed and mulch area.

Measurement and Payment

Concrete Washout Structure will be paid for per each enclosure installed in accordance with the details. If alternate details or commercially available devices are approved, then those devices will also be paid for per each approved and installed device.

Temporary Silt Fence will be measured and paid for in accordance with Article 1605-5 of the *Standard Specifications*.

Safety Fence shall be measured and paid for as provided elsewhere in this contract.

No measurement will be made for other items or for over excavation or stockpiling.

Payment will be made under:

Pay Item	Pay Unit
Concrete Washout Structure	Each

LITTER REMOVAL (MOWING AREAS ONLY):

(07-19-22)

Description

This work consists of the pickup, removal, and disposal of litter from roadsides within the construction project prior to mowing operations.

Construction Methods

Provide labor, equipment and materials necessary for the pickup and removal of litter from non-construction sources and the disposal of same into state approved landfills. The Contractor shall abide by all ordinances, laws and regulations regarding disposal of litter and recycling of eligible materials. Wastes generated from construction activities shall be managed as provided elsewhere in the contract. Litter items may consist of any item not considered normal to the right-of-way, including but not limited to, varied sizes of bottles, cans, paper, tires, tire pieces, lumber, vehicle parts, building supplies, metals, household furnishings, cardboard, plastics, ladders, brush and other items not considered normal to the right of way. Litter removal shall be performed in designated areas within five days prior to any mowing operations and as directed. Designated areas shall include vegetated medians and shoulders within the project limits including all interchange ramps and other areas to be mown. Designated areas may be omitted for litter removal by the Engineer due to safety concerns.

The Contractor shall provide adequate personnel and materials to collect and remove litter. The Contractor shall be responsible for locating and utilizing approved local landfills and recycling facilities. Refer to Section 105-27 of the *Standard Specifications* for potential hazardous materials. All collected litter shall be containerized immediately and kept off the traveled portions of the roadway, shoulders, and rights-of-way (including paved shoulders). All collected litter that is small enough to be placed in a bag shall be bagged immediately. All collected litter that is too large for a bag shall be placed into a vehicle. Extended storage or stockpiling of collected litter and recyclables will not be permitted.

The Contractor's personnel shall dispose of any litter in a landfill approved by North Carolina Division of Waste Management. The Contractor will not be allowed to use NCDOT accounts at the landfills/recycling centers nor be allowed to dispose of the litter in NCDOT trash containers on any NCDOT property.

The Contractor shall report online the number of bags of litter and any recycling on the NCDOT Litter Management Website on the date of the pickup at the following website:

<https://apps.ncdot.gov/LM>

An access code ('Pickup Key') for the online reporting portal may be obtained via emailing the Roadside Environmental Unit Litter Management Section at ncdot.clr@ncdot.gov. The Contractor shall request access to the litter removal reporting website prior to starting initial litter collection operations.

Measurement and Payment

The quantity of litter removal to be performed will be affected by the actual conditions that occur during construction of the project. The quantity of litter removal may be increased, decreased, or eliminated entirely as directed. Such variations in quantity will not be considered as alterations in the details of construction or a change in the character of the work.

Manual Litter Removal will be measured and paid as the actual number of man hours each worker spends picking up litter. Such price and payment will be full compensation for all litter removal work covered by *Litter Removal*, including, but not limited to, furnishing all materials, labor, equipment, transport, reporting, and incidentals necessary to accomplish the work.

Litter Disposal will be measured and paid for by the actual number of tons of litter collected and properly disposed of at a state approved landfill. Such price and payment will be full compensation for all fees, labor, transport, and incidentals necessary to dispose of collected litter associated with *Litter Removal*.

All traffic control necessary to provide a safe work area for *Litter Removal* shall be paid for as specified elsewhere in the contract.

Payment will be made under:

Pay Item	Pay Unit
Manual Litter Removal	MHR
Litter Disposal	TON

FABRIC INSERT INLET PROTECTION DEVICE (HIGH FLOW)

(6-29-17)

Description

This work shall consist of installing, maintaining, and removing *Fabric Insert Inlet Protection Device*, of the type specified, in inlet structures (catch basins, drop inlets, etc) in areas where asphalt or concrete may prevent the proper installation of a Rock Inlet Sediment Traps Type C, or as directed.

Materials

The product shall be a fabric inlet protection device composed of a fitted woven polypropylene geotextile double sewn with nylon thread suspended sack. The *Fabric Inlet Protection Device* shall be manufactured to fit the opening of the catch basin or drop inlet or shall have a deflector to direct runoff from the curb opening into the fabric sack. The *Fabric Inlet Protection Device* shall have a rigid frame or support system to support the loaded weight of the product. The product shall have lifting loops for removing the device from the basin and will have dump straps attached at the bottom to facilitate the emptying of the device. The *Fabric Inlet Protection Device* shall have an overflow system to allow stormwater to enter the inlet structure and avoid ponding on the roadway when the device reaches capacity.

The stitching shall meet the following physical properties:

Physical	Test Method	English
Average Wide Width Strength	ASTM D-4884	165 lb/in

The fitted filter assembly shall have the following physical properties:

Physical	Test Method	English
Grab Tensile	ASTM D-4632	255 x 275 lbs
Minimum Puncture Strength	ASTM D-4833	125 lbs
Mullen Burst	ASTM D-3786	420 PSI
Minimum UV Resistance	ASTM D-4355	70 %.
Flow Rate	ASTM D-4491	200 gal/min/ft ²
Apparent Opening	ASTM D-4751	20 US Sieve
Permittivity	ASTM D-4491	1.5 sec ⁻¹

Construction Methods

Strictly comply with manufacturer's installation instructions and recommendations. Maintenance shall include regular daily inspections and after each qualifying rain event. The *Fabric Inlet Protection Device* shall be emptied, cleaned and placed back into the basin when it reaches 50% capacity or as directed.

Measurement and Payment

This work will be paid for at the contract unit price per *Fabric Inlet Protection Device* of the type specified, complete in place and accepted. Such payment shall be full compensation for furnishing and installing the *Fabric Inlet Protection Device* in accordance with this specification and for all required maintenance.

Maintenance of the device, cleanout and disposal of accumulated sediments shall be paid for by *Fabric Inlet Protection Device Cleanout*.

Payment will be made under:

Pay Item	Pay Unit
Fabric Insert Inlet Protection Device	Each
Fabric Insert Inlet Protection Device Cleanout	Each

TACK FOR MULCH FOR EROSION CONTROL:
(07-19-22)

Description

This work consists of supplying and installing of an approved material for binding mulch for erosion control in accordance with Section 1060-5, Section 1615 and Section 1660 of the *Standard Specifications*. This provision defines acceptable materials and rates for tacking material for holding mulch in place.

Materials

(a) Emulsified Asphalt

Asphalt emulsion tack shall conform to the requirements of AASHTO M 140, Specification for Emulsified Asphalt. The emulsified asphalt may be rapid setting, medium setting, or slow setting. Apply emulsified asphalt tackifier at a rate of 0.10 gallons per square yard (approximately 484 gallons per acre).

(b) Cellulose Hydromulch

Cellulose hydromulch products shall be non-toxic, weed-free, prepackaged cellulose fiber (pulp) material containing no more than 3% ash or other inert materials. Cellulose hydromulches may contain dyes or binders specifically formulated to enhance the adhesive qualities of the hydromulch. Apply cellulose hydromulches at a rate of 1000 pounds (dry weight) per acre.

Wood fiber or wood fiber blend hydromulches may be substituted for cellulose hydromulch at the same application rate.

(c) Other tackifiers

Other approved materials, specifically designed and manufactured for application as a straw mulch tacking agent, may be used at the manufacturer's recommended rate.

Construction Methods

Apply the Tack for Mulch for Erosion Control uniformly across straw mulch per Section 1615 and Section 1660 of the *Standard Specifications*.

Payment

Tack for Mulch for Erosion Control is incidental to the application of *Temporary Mulching*, Section 1615-4, and *Seeding and Mulching*, Section 1660-8, and no additional payment will be made.

R-5799

L1

Transylvania County

R-5799 Landscape Betterment Special Provisions



DocuSigned by:
Teresa Buckwalter
1D84E0268A06420...

9/25/2023

Table of Contents:

<u>DESCRIPTION</u>	<u>PAGE</u>
PLANTING	L2
ESTABLISHMENT.....	L8
SHREDDED BARK MULCH.....	L8
STEEL LANDSCAPE EDGING.....	L9
SOIL AMENDMENTS.....	L10
SODDING.....	L11
BOULDERS, RIVER ROCK AND FLAGSTONE.....	L14
LANDSCAPE LIGHTING.....	L16
TIMBER FENCING.....	L17

R-5799

L2

Transylvania County

PLANTING

Furnish, deliver and plant trees, shrubs, vines, ground covers, bedding plants and seedlings at locations shown in the plans or as directed, in accordance with these Specifications.

The work of planting includes plant bed preparation, initial planting, plant establishment and replacement planting. Perform the operations carefully to promote the continued life and healthy growth of all plants in their final location.

The actual conditions that occur during the construction of the project will determine the quantity of plant bed fumigation or post-emergent and pre-emergent herbicidal treatment for plant beds. The quantities of plant bed fumigation and post-emergent and pre-emergent herbicidal treatment for plant beds may be increased, decreased or eliminated entirely as directed. Such variations in quantity will not be considered as alterations in the details of construction or a change in the character of the work.

MATERIALS

Furnish nursery grown plant materials.

Use methyl bromide as fumigant consisting of a mixture of 80% methyl bromide and 20% chloropicrin. A different ratio of fumigant containing methyl bromide and chloropicrin may be used provided that the amount of active ingredient specified in Article 1670-7 is provided.

Use a 2 mil. polyethylene agricultural plastic sheeting free of holes, punctures and tears to cover the fumigated plant beds. Use an appropriate width of plastic for the width of the plant bed and obtain approval before fumigation.

WEATHER AND SEASONAL LIMITATIONS

Perform planting operations only between the dates shown in the contract except where otherwise permitted in writing.

Do not plant when the temperature is below 32°F, when the plant hole is frozen or when soil to excavate and fill the plant hole is frozen or too wet.

Perform fumigation during or within 2 weeks before the time allowed for planting as shown in the contract. Fumigate when the soil temperature is at least 55°F at a depth of 5" and moderately moist (50-85% of field capacity).

Apply post-emergent herbicide when the weeds are near maturity but not when the weeds are under stress from drought, disease, insect damage or any other cause.

Do not apply post-emergent herbicide when rain is likely within the next 6 hours or as restricted on the product label.

CARE AND HANDLING PLANTS**(A) General**

Exercise utmost care in digging, loading, transporting, unloading, planting or otherwise handling plants and use adequate precautions to prevent injury to or drying out of the trunk, branches or roots; and to prevent freezing of the plant roots. Heel-in plants within 48 hours of delivery from the nursery, if they cannot be planted within that time.

R-5799

L3

Transylvania County

Properly maintain all heeled-in plants until planted. Do not have plants remain heeled-in for more than 30 days. Open plants immediately when delivered in boxes or wrapped in bundles or other forms of closed packages and inspect and dampen if necessary.

(B) Balled and Burlapped Plants

Protect the roots of balled and burlapped plants, if not immediately planted after delivery, by adequately covering with a soil, mulch or sawdust that is kept moist constantly in an acceptable manner appropriate to weather or seasonal conditions. Preserve the solidity of the plant ball carefully.

(C) Bare Rooted Plants

Refrigerate or immediately heel-in all plants, if not promptly planted, in moist soil, mulch or sawdust in an acceptable manner corresponding to generally accepted horticultural practice. Protect the plants from drying out by means of wet canvas, burlap or straw or by other means acceptable while being transported or planted.

(D) Geophytes

Geophytes; bulbs, corms and tuberous plants; that are being shipped shall be packaged in containers that meet industry standards and have been pre-approved by the Landscape Architect. All individual packages shall be clearly labeled with quantity and cultivar name. While bulbs, corms and tuberous plants are being transported or are being distributed in planting beds, or are awaiting planting after distribution, protect them from drying out by means of wet canvas, burlap, or straw, or by other means acceptable to the Landscape Architect and appropriate to weather conditions and the length of time they will be out of the ground.

Care shall be taken to avoid unnecessary injury to the bulbs before planting.

Pre-plant cool treatment is required for plants planted in a USDA Climatic Zones 9 and 10. Storage of bulbs, corms and tuberous plants which do not require pre-plant cool treatment shall be stored in open trays and placed in a 55°F - 65°F, dry place away from frost and heat and never allowed to dry out to the point of shriveling. Packing in slightly moist peat is preferred. The storage area shall be well-ventilated and ethylene-free. Do not store bulbs with fruit such as apples or pears which produces ethylene gas which can cause problems with flowering. Do not store bulbs in paper or plastic bags unless otherwise specified or approved. If a refrigerator is used it shall be frequently ventilated.

PLANT LOCATION

Locate and mark on the ground locations for plants and outlines for areas to be planted reforested and obtain approval before digging plant holes for beds. Where so directed, furnish and install standard identification wires with plastic flags to designate individual plants in major planting areas.

Flags will not necessarily be needed for all plants required by the contract, but use these flags on portions of the project until plant locations in these portions are approved.

Unforeseen conditions may make it necessary to make minor adjustments in plant locations due to utility lines, traffic signs, rock, drainage, etc., and such adjustments will be permitted subject to approval.

R-5799

L4

Transylvania County

PRUNING

Pruning done at any time in no way alters the Department's right to reject plant material. Prune in accordance with the International Society of Arboriculture pruning techniques, and according to shape, size and condition of the individual plant.

PLANT BED TREATMENT**(A) General**

Treat plant beds by fumigation or by application of herbicides where called for by the plans or directed.

(B) License

Make pesticide applications by or under the direct supervision of an applicator licensed by the North Carolina Department of Agriculture and Consumer Services.

(C) Fumigation

1 Fumigate the plant beds with an approved fumigant in preparation for planting. Before fumigation, level the plant bed to a proper planting grade. Till the bed to a depth of 5" to 8". Prepare soil in good tilth with no dry clods over one inch in diameter present. Cover with plastic tarp within 24 hours of soil preparation completion or other approved process.

Apply the approved fumigant gas according to product labeling. If plastic is required then Use envelope folds at the edges of the bed with the edge of the plastic buried 4" to 6" deep. Keep the plastic over the bed for 48 to 72 hours. Reform the bed to the required shape, after removal of the plastic, with little or no soil inversion. Pursue continuous planting within 24 hours of plastic cover removal.

(D) Post-Emergent Herbicidal Treatment

Post-emergent herbicidal treatment includes applications of a systemic post-emergent total vegetation control herbicide.

The contract will state the rates of application of the post-emergent herbicides.

Apply all herbicides in accordance with the manufacturer's instructions on the product label.

Apply post-emergent herbicide when the weeds are near maturity but not when the weeds are under stress from drought, disease, insect damage or any other cause. If cloudy weather or other poor growing conditions are present, extend this 7 day period until there are visible signs of herbicidal activity. Reapply if necessary to achieve a thorough control.

(1) Post-Emergent Application for Plant Bed Preparation

Apply a systemic post-emergent total vegetation control herbicide to the bed area before any tilling or mowing is performed. Perform no tilling or mowing for at least 7 days after the application. Thoroughly till the bed after the waiting period, or when injury to the vegetation appears. Prepare the soil in good tilth with no clods over one inch present and before planting.

(2) Post-Emergent Application for Plant Bed Maintenance

Apply a systemic post-emergent herbicidal treatment in accordance with product

R-5799

L5

Transylvania County

label in a manner to ensure no damage to planted material. Perform no mowing or vegetation removal by other means for at least 7 days after the application.

(E) Pre-Emergent Herbicidal Treatment

Pre-emergent herbicidal treatment includes the application of a pre-emergent herbicide. Apply a pre-emergent herbicide to the plant bed after the existing vegetation has been completely controlled by a post-emergent herbicide application as specified in Sub article 1670-7 (D) and after installation of planting and mulching as described in Articles 1670-9 and 1670-10. Apply pre-emergent herbicide following planting and mulching of plant bed before germination of weed seeds. An additional application of post-emergent herbicidal treatment may be necessary to control emerged weeds, as directed, if sufficient time has lapsed between tillage and installation of plant material and mulch. No direct payment will be made for additional post-emergent herbicidal work if such work is due to carelessness or neglect on the part of the Contractor.

Apply herbicide evenly over the soil surface with properly calibrated equipment at the specified rate.

If at least 0.5" of rainfall does not occur within 15 days of application of pre-emergent herbicidal treatment, apply at least 0.5" of water (2.8 gal/sy uniformly over the planting area to activate the herbicide.

EXCAVATION OF PLANT HOLES

Provide cylindrical shaped plant hole excavations for plants other than reforestation plants, with the plant location stake marking the center of the circle and with the sides of the hole being approximately vertical. When mechanical means are used which make digging of cylindrical holes impractical, the complete hole shall have the minimum dimensions as shown in the plans.

When plants are to be grouped together in a plant bed as contrasted to widely separated individual plants, and when so indicated in the plans, loosen and pulverize clods to a depth of not less than 5" for the entire area of the plant bed by means of a scarifier, disc, spade or other appropriate means before plant holes are dug.

Place plants in holes made by a planting spade, planting bar or other means which meet the approval of the Landscape Architect. Make the hole of sufficient size to accommodate the entire plant structure without cramping. Take care to plant all plants at a uniform depth as indicated in the plans or directed by the Landscape Architect.

When geophytes are to be planted separately as individual plants or in small separated groups, loosen and pulverize clods with a spade, auger or other means which meet the approval of the Landscape Architect. Individual planting holes shall be to a depth of not less than 8", or sufficient size to accommodate the entire plant structure without cramping or to a depth as indicated in the plans or directed by the Landscape Architect.

PLANTING, BACKFILLING AND WATERING**(A) General**

The plans will state the kind and rate of application of fertilizer. Apply fertilizer during backfilling operations in a manner that will ensure proper placement of the fertilizer and

R-5799

L6

Transylvania County

avoid injury to the roots.

Scarify the walls and floor of the plant hole after the plant hole is dug. Place the plant in the prepared plant hole at the proper position as regards to depth, alignment, final grade of the surrounding ground level and vertical placement of the trunk. Maintain this position during all subsequent backfilling and watering operations. Set plants with the root collar at the same depth as grown in the nursery or raise above grade as indicated in the plans.

Moisten the soil with water after one-half to two-thirds of the backfilling and tamping has been completed, if the soil in the plant holes is not sufficiently moist. Apply water to moisten all soil but not a quantity that will saturate the soil to the extent of excluding all air from around the roots. Place the remainder of the backfill after complete absorption of water.

Construct water rings around all plants, except reforestation plants, in accordance with details shown in the plans. A water ring consists of a ridge of firmed soil in a ring around the plant and of a minimum inside diameter equal to the diameter of the plant hole. This ridge is approximately 6" high and is compacted firmly enough to hold water.

(B) Balled and Burlapped Plants

Handle balled and burlapped plants by the ball and place in the plant hole so that the soil of the ball will not be loosened from the roots. After the hole has been almost completely backfilled and the soil thoroughly firmed under and around the ball, cut the burlap away and remove from around the stem of the plant. Complete backfilling so as to avoid loosening of the soil of the root ball.

(C) Container Grown Plants

Planting requirements for container grown plants are the same as applicable to balled and burlapped plants. Remove container immediately before planting. During the removal of the container, take sufficient precautions to ensure that the soil and roots inside the container are undisturbed. Scarify roots when directed.

(D) Bare Rooted Plants

Before the plant is placed in the plant hole, cut off smoothly any bruised or broken parts of roots. Place the plant in its proper position in the hole and backfill. Carefully place the backfill material, worked around and under the roots and compacted in a manner that avoids bruising or breaking the roots.

WATER FOR PLANTING

Water at the time of planting as specified in Article 1670-9 and at the Contractor's election and the Landscape Architect's approval. Water with gravity flow or low pressure applicators which have been approved, and which will not erode soil around the plant root system or damage to plants. Saturate the soil around each plant thoroughly at each watering.

STAKING OR GUYING

Stake or guy plants as shown in the plans or as directed to prevent damage.

R-5799

L7

Transylvania County

Ensure that the plant is attached and held rigid to the support in a manner that will prevent chafing or other injury to the bark, and that will permit normal development of the trunk or branch.

INITIAL PLANTING

Initial planting will be complete when the plants have been placed in the plant hole, backfilled, fertilized, watered, mulched, staked and guyed, and the plants are in an acceptable condition.

ESTABLISHMENT

Begin establishment for all initial or replacement plants immediately after they are planted. Maintain trees, shrubs, vines and groundcovers, and the area of planting until final acceptance of the project. Mow and maintain the area around trees and shrubs for a distance of 6 ft. beyond the outside limits of water rings or 6 ft beyond the limits of the guy stakes, whichever is greater; within shrub beds; and for a distance of 6 ft outside the perimeter of the shrub beds.

Establishment includes cutting of grass and control of weeds; watering; fertilization; replacement of mulch; repair or replacement of guy stakes, guy wires and water rings; and other work as directed to ensure the survival and growth of plant material and the satisfactory appearance of the project. Remove dead plant material from the project during the establishment period.

REPLACEMENT PLANTING

Replacement planting of trees, shrubs and ground cover consists of replacing those plants which are not in a living, healthy condition or do not conform to the Specifications contained in American Standard for Nursery Stock or damaged or stolen. Replacement of reforestation plants will not be required. Perform replacement planting within the planting season specified in the contract.

FINAL INSPECTION

All planting shall be completed and all plants shall be in a living and healthy condition at the time of final inspection.

MEASUREMENT AND PAYMENT

Plant Species and Size Indicated in Contract will be measured and paid in units of each.

Mulch for Planting will be measured and paid in cubic yards. Where mulch is furnished in bales or bags, the number of cubic yards in each bale or bag will be determined and then multiplied by the number of bales or bags of the same size which have been acceptably furnished and placed. Load each truck to at least its measured capacity at the time it arrives at the site of the work.

No payment will be made for plant bed preparation, tillage, staking or guying and fertilization, for this work will be incidental to other work in the contract.

Individual planting items will be measured and paid in accordance with Article 1670-17 of the *Standard Specifications*.

R-5799

L8

Transylvania County

ESTABLISHMENT

Seasonal Limitations: The initial planting and replacement of plants will be accomplished between October 15th and April 31st for all woody plant material (trees, shrubs and ground covers). All herbaceous plants and containerized grasses will be planted between September 1st and October 31st or between May 5th and June 5th depending on requirements of each species. Exceptions to these seasonal limitations are at the discretion of the Landscape Architect and will be submitted in writing. Submit for approval proposed schedule for plant installation, along with plant sources and contact information for them, by March 15th of the year that planting is to begin.

Establishment Period for Planting: An establishment period will begin after satisfactory installation and acceptance of all of the planting. All plants must be in an upright healthy condition, planted at the proper depth, mulched areas will be weed free and tidy, fresh, and any staking or guying that is utilized must be in proper condition prior to beginning the establishment period. During the establishment period the contractor will be responsible for proper care of the plantings in accordance with Section 1670-14 Establishment.

All plants that do not continue to conform to the specifications and quality as approved when they were installed will be unacceptable. The contractor will remove all plants that are determined to be unacceptable from the site and make replacements within five days of request by the Landscape Architect unless its outside the planting season. Replacements will be installed within the Seasonal Limitations.

Each quarter during the establishment period a meeting will be held between the Landscape Architect and the Contractor to discuss establishment work required during that period. Additional meetings may be scheduled if deemed necessary by the Landscape Architect. All the required work will be performed in a timely manner and with utmost regard to the safety and convenience of the installation. Failure on the part of the contractor to complete the required work in a satisfactory manner will result in the Department having the work performed by others and paid for by the Performance Bond.

All requirements of Section 1670-14 Establishment will also be applicable during the Establishment Period for Planting. The Establishment Period for Planting will last a minimum of 18 months and extend into the seasonal limitations for planting in order to allow replacement plantings to be installed. See contract times for exact time period and dates. During the establishment period, the shrub and perennial plants in the roadway islands, and where site distance is critical, will be maintained at a maximum height of 2 feet.

SHREDDED BARK MULCH**Materials**

Shredded bark mulch shall consist of shredded bark and wood. Maximum length of any individual component shall be two inches (2") and a minimum of seventy-five percent (75%) of the mulch shall pass through a one inch (1") screen. Mulch shall be free of germination-inhibiting ingredients. The bark mulch shall have the characteristics of retaining moisture,

R-5799

L9

Transylvania County

forming a mat not susceptible to spreading by wind or rain, and providing a good growth medium for plants. Shredded bark much may contain up to fifty percent (50%) shredded wood material. Wood chips are not acceptable. Bark mulch containing shredded wood shall be aged a minimum of one year prior to installation. Bark mulch shall be free of soil, rocks, and weeds.

Measurement and Payment

Payment will be made under:

Mulch Cubic Yard

STEEL LANDSCAPE EDGING

1. Steel Landscape Edging Size: Comply with ASTM A 621, hot rolled, standard flexible carbon steel landscape edging, fabricated in sections with stake pockets stamped and punched along sections approximately thirty-six inches (36”) apart to received stakes. Steel landscape edging shall be double staked at overlap joints, and designed to receive tapered steel stakes.

- a. 1/8” thick (10 gauge) x 6”

2. Steel Landscape Edging Finish:

- a. Black powder-coated.

3. Steel Landscape Edging Stakes:

- a. 1/8” standard pocket 10 gauge specify staking as follows:

PS-Stakes:

Steel, tapered, 12” length and finished to match specified steel landscape edging. Stakes designed specifically to anchor steel landscape edging in place, and made by the manufacturer of the steel landscape edging for which they will be used.

INSTALLATION OF LANDSCAPE EDGING

A. Steel Landscape Edging: Install steel landscape edging according to manufacturer’s recommendations. Anchor with steel stakes spaced approximately 36 inches on-center, driven below top elevation of edging, or at every stake pocket location in landscape edging sections designed and manufactured to receive stakes. Stakes shall be located in solid undisturbed soil, or in proper soil compaction.

- 1. **Horizontal Alignment:** Install straight and curved sections true to the alignments as indicated, free of waves or bends, using strings as guides. Follow the marked alignments as per site drawings. Allow the Landscape Architect to review the layout.
- 2. **Vertical Alignment:** Install parallel with the finished grade.
- 3. **Damaged Edging:** Replace steel edging sections damaged during construction operations.

Measurement and Payment

Payment will be made under:

Landscape Edging Linear Foot

R-5799

L10

Transylvania County

SOIL AMENDMENTS**General**

Landscape and Site grading consists of placing topsoil material within planting beds, and cutting and backfilling within the roundabout, right-of-way and splitter islands, to provide proper drainage and elevations as indicated on the grading plans, cross-sections, and as directed by the Landscape Architect. Fine grading shall provide a natural, rolling slopes rather than uniform slopes.

Material

Soil preparation must be conducted by contractor to de-compact soils to allow for root growth. Soil preparation of compacted soils is a critical factor in plant survival and growth. The following steps shall be followed to evaluate whether the existing soils on site can be used and the steps that need to be taken to prepare the soil for planting.

SOIL TEST: Soils shall be tested at the contractor's expense. A minimum of 5 core 6" soil samples shall be tested from various landscape beds throughout the project area.

SOIL TEST: Soil tests shall determine soil texture (mechanical analysis), pH, magnesium, phosphorus, potassium, soluble salts, total calcium, nitrogen, and percent organic matter. If the soil is sandy, it shall also be tested for boron. The Contractor shall submit plans with the soil test results showing the locations of all soil tests. Incomplete test results and plans may be rejected by Landscape Architect, and shall be redone at the Contractor's expense.

AMEND BASED ON TESTING: Soil test results shall include laboratory recommendations for soil amendments to correct deficiencies and accomplish planting objectives. Follow recommendations of laboratory and/or Soil Part 7 section 3.2 of the Landscape Contractors Association MD DC VA Specification Guidelines and provide course of action based on their recommendation.

SOIL AMENDMENT: Topsoil shall be amended with organic matter to make a positive change in bulk density and macroporosity. A 2" layer of organic amendment (such as peat moss or composted/aged pine bark fines) shall be tilled or dug to a minimum depth of 12"- 18" throughout all landscape beds.

REPORT: Commencement of work will not begin until all submittals have been approved by the Landscape Architect. This includes but not limited to soil testing results and recommendations.

Installation

Uncompacted topsoil with a depth of 12" for perennial/ornamental grass beds and 18" for beds containing shrubs and trees much be present at all landscape areas. Do not place topsoil when the ground is frozen, is excessively wet, or is in a condition that the soil cannot be worked easily and dressed smoothly.

Where fill material is needed within wooded areas, precautionary measures will be taken to prevent damage to trees and the roots of trees to be retained for landscape purposes. When placing or compacting fill material in or adjacent to wooded areas heavy machinery will not be

R-5799

L11

Transylvania County

allowed. Equipment for placing fill material will be approved by the Landscape Architect prior to any grading work.

Compensation

Soil amendment will be paid for in the actual number of cubic yards of organic matter placed and accepted.

Such price and payment will be full compensation for furnishing, all labor, equipment and all incidentals necessary to complete the work satisfactorily.

Payment will be made under:

Soil Amendment Cubic Yards

SODDING: HARD FESCUE/BUEGRASS or ZYSOIA

This work consists of placing sod in the median and other roadside areas, as directed. The sod shall be prepared in accordance with the requirements of Section 1664 of the *Standard Specifications* and the requirements of this section. See the Landscape Plans (L1-L12 and Consultant Plans) for areas to be sodded.

Materials

Only "approved sod" (trade designation) consisting of a mixture of 50% Kentucky Bluegrass and 50% Hard Fescue or Zoysia shall be used. The sod, machine cut to the suppliers standard width and length, shall be 5/8" minimum, excluding top growth and thatch, at the time of cutting. Before cutting, the sod shall be uniformly mowed at a height of 1 ½" to 2 ½". Standard sod sections shall be sufficiently strong to support their own weight and retain their size and shape when suspended vertically from a firm grasp on the upper 10% of the section. The sod may be either 42" wide roll sod or 18" by 36" strips.

Approved Kentucky Bluegrass Cultivars:

Adelphi	Brilliant	Kenblue	Princeton
Apollo	Bristol	Liberator	Ram I
Bariris	Challenger	Merit	Rugby
Baron	Columbia	Nuglade	Sydsport
Baronie	Fylking	Odyssey	Touchdown
Bartitia	Glade	Plush	Vantage

Approved Hard Fescue Cultivars:

Aurora	Minotaur	Scaldis	Waldina
--------	----------	---------	---------

R-5799

L12

Transylvania County

Bardur
CrystalNordic
ReliantSpartan
Valda

Warwick

The Contractor shall obtain a certificate or limited permit issued by the North Carolina Department Of Agriculture and Consumer Services (1-800-206-9333) or (919-733-6932) stating that the sod has been found to be free of injurious plant pests.

Sod shall be delivered on site within 24 hours of being cut and be covered by acceptable means during delivery. A certificate from the sod producer stating the date and time of sod cutting shall accompany the sod when it arrives at the project site.

The Contractor shall provide sufficient water to meet the requirements of this section.

Construction Methods

(A) Soil Preparation

Remove litter and other debris. Mow and satisfactorily dispose of weeds or other unacceptable growth on the areas to be sodded.

Prior to beginning preparation of the soil to receive sod, all eroded, uneven and rough areas shall be contour graded and/or filled with soil as directed. The soil shall be scarified or otherwise loosened to a depth of not less than 5". Clods shall be broken and the top 2" to 3" of soil shall be worked into an acceptable soil bed by the use of soil pulverizers, drags, or harrows.

After soil preparation, lime and fertilizer shall be uniformly distributed by mechanical means using a 42" drop-type spreader and thoroughly mixed with the top 5" of the soil by disking, harrowing, or other approved methods. The rates of lime and fertilizer per acre are as follows:

500#	10-20-20 Fertilizer
4000#	Limestone

The area shall then be harrowed, dragged, raked, or prepared by other approved methods which will give a lawn type finish. All trash, debris and stones larger than 1 ½" in diameter or other obstructions that could interfere with the placing of the sod shall also be removed. The finished surface shall be moistened with water prior to placing the sod as directed.

(B) Sod Placement

Sod handling and placement shall be a continuous process of cutting, transporting and installing including repairing seams and voids. Sod shall always be installed within 48 hours after being cut. Sod shall be watered within 2 hours of installation.

Any sod or portions of sod rejected by the Landscape Architect during the initial placement shall be removed from the project and replaced with acceptable sod immediately. The Contractor shall cease any and all other placement of sod on the project until rejected sod has been replaced.

09/25/23

R-5799

L13

Transylvania County

After sod has been placed, and staked where necessary, according to Section 1664 of the *Standard Specifications*, it shall then be rolled or tamped carefully and firmly by means acceptable to the Landscape Architect to ensure proper soil contact. If rolled, roller shall weigh 150 lb/ft of roller width. Use of rubber-tired equipment to roll shall not be allowed. Metal staples, 12" long unless otherwise approved, shall be made of 11-gauge new steel wire so as not to bend when pinned or driven through the sod. Extreme care shall be taken to prevent the installed sod from being torn or displaced. After rolling or tamping the sod, it shall be watered uniformly and thoroughly with a minimum of 1" of water, 5.6 gallons per square yard, applied immediately after installation of sod. In no case shall the time interval between sod placement and initial watering exceed 2 hours. Water shall be placed to the required quantity through sequential passes to insure proper coverage and to prevent runoff. A minimum of ¼" should be placed on each pass.

(C) Maintenance

The City of Brevard will provide water and mowing services for the sod. The Contractor shall be responsible for coordinating with the City of Brevard to ensure that the sod is watered and maintained until final acceptance, including monitoring the sod to ensure all watering and other maintenance is performed as required.

Each additional watering event shall be a minimum of 0.5" of water, 2.8 gallons per square yard, uniformly applied over the sodded area and may be placed in a series of passes to prevent runoff, with a minimum of ¼" on each pass.

Any sod or portions of sod rejected by the Landscape Architect after placement, but prior to beginning the observation period, shall be removed from the project and replaced by the contractor with acceptable sod. Satisfactory replacement of sod shall begin within 10 days of notification. Failure to replace and repair damaged or dead sod as directed may result in sanctions under Article 108-7 or Article 108-8 of the *Standard Specifications*.

(D) Observation Period

The observation period for the sod on this project shall be from March 1 to October 1. Sodding shall be inspected by the Roadside Environmental Field Operations Landscape Architect to begin and end the observation period.

The Contractor shall maintain responsibility for the sod for an observation period beginning upon the satisfactory completion and acceptance of all work required in the plans or as directed. The Contractor shall guarantee the sod under the payment and performance bond in accordance with Article 109-10 of the *Standard Specifications*.

The observation period for sod installed between August 31 and March 1, shall not begin until March 1. Installation of sod shall be permitted between August 31 and March 1. However, the Landscape Architect shall not accept such work and begin the observation period prior to March 1. Upon satisfactory completion of work and acceptance by the Landscape Architect, the observation period shall begin.

R-5799

L14

Transylvania County

After the first 30 days of the observation period, and every 30 days thereafter throughout the observation period, the Contractor and Landscape Architect shall meet to review the project and identify dead or damaged sod to be replaced. The Contractor, at no additional expense to the Department, shall satisfactorily replace any sod that is not in a living and healthy condition as determined by the Landscape Architect. Replacement sod shall be furnished and installed in accordance with the same requirements as for initial sodding operation, except that the amounts of limestone, sulfur, and water may be readjusted as directed. Satisfactory replacement of sod shall begin within 10 days of notification. Failure to replace and repair damaged or dead sod as directed may result in sanctions under Article 108-7 or Article 108-8 of the *Standard Specifications*. Upon completion and acceptance of the sod repairs, the next 30 days of the observation period shall begin.

(E) Acceptance

At the end of the observation period, the sod furnished and installed under this contract must be in a living and healthy condition, as determined by the Landscape Architect. Acceptance of sod will be either at the end of the observation period or at final acceptance of the project, whichever is later. The sod shall be weed free at time of final acceptance.

Measurement and Payment

Payment will be made under:

Sodding Square Foot

BOULDERS, RIVER ROCK AND FLAGSTONES

General

This special provision consists of procuring and installing the boulders flagstone and river rock as shown on the plans and details and as described herein.

Materials

Contractor shall furnish boulders, flagstone river rock similar in appearance, color, type and approximate size as shown on the Landscape Plans. Landscape Architect will approve boulder, flagstone and river rock selection via in person or from photographs. No evidence of drilling, scrapes, large flakes or cracks shall be visible after the boulder is set in place.

Installation

Placement of boulders will be at the direction of the Landscape Architect and will require the cooperative effort of the contractor to maneuver into the desired position. Excavate and place boulder so that it sits embedded in the plant bed and not on top. Backfill around boulder with plant bed media or landscape graded areas. Boulders shall be placed at locations shown on plans or as designated by the Landscape Architect at appropriate stages of construction.

R-5799

L15

Transylvania County

Contractor shall supply to the Landscape Architect a staging plan showing the time frame of installment of stones and how contractor will not damage any existing and proposed hardscape (i.e. roads and sidewalks).

Flagstone shall be irregular, standup flagstone. The thickness shall be 2” and the size shall be between 3 and 9 square feet per piece. The pieces shall be fit together to form the dimensions shown in the Consultant Landscape Plans. The color shall be gray and prior approval by Landscape Architect must be sought. Flagstone shall be on a sand setting bed. Sand shall be construction grade sand.

See the Consultant Landscape Plans

Care shall be taken during transport, delivery and placement to prevent chipping, cracking or scarring of surfaces of flagstone, river rock and boulders. Boulders shall be placed in such a way so that they will be immovable and will not roll.

Compensation

River rock will be paid for in cubic yards; flagstone will be paid for in tons. The work of furnishing and installing boulders when completed and accepted, will be paid for at the contract unit price per each 'Boulder'. Such price and payment will be full compensation for all work covered by this special provision; including but not limited to furnishing all labor, delivery materials, equipment and any other incidentals necessary or required to complete the work.

Small Boulders: 5 CF-10 CF (6 boulders)

Medium Boulders: 15 CF-25 CF (5 boulders)

Care shall be taken during transport, delivery and placement to prevent chipping, cracking or scarring of surfaces. Boulders shall be placed in such a way so that they will be immovable and will not roll.

Payment will be made under:

Small boulders	Each
Medium boulders.	Each
Flagstone	Ton
River Rock	Cubic Yards
Sand for setting bed.....	Cubic Yards
Incidental stone base.....	Ton

LANDSCAPE LIGHTING

Contractor will coordinate with Utility location of new meter can and minimum 100 amp main breaker panel to facilitate lighting of new roundabout interior landscaping. All wiring/conduit/ocp to be installed fully-functional and operational under NFPA70/NEC, in damp,

R-5799

L16

Transylvania County

wet-rated, or otherwise weather-tight enclosures rated for exterior application. 5/8" copper ground rods with 6awg solid copper equipment bonding wire to be located at main panel and at roundabout interior receptacles.

Contractor will coordinate scheduling with NCDOT installation of 1-1/2" pvc sch40 or equal conduit under proposed roadway from new panel to roundabout interior. Two (2) 120v 20-amp GFCI receptacle circuits will make power available for low-voltage transformers and 24v lighting within the roundabout landscaping areas noted on plans, estimated ~130'-0" from Utility meter location. (1) 120v 20-amp GFCI receptacle to be provided at panel locations. All 120v circuits to utilize 12g UF or THWN wiring rated for burial in rigid conduit at min 36" burial depth with weathertight in-use rated covers. 120v GFCI outlets and 24v transformer will be attached to 4x4 pressure treated pole, stained with SHERWIN WILLIAMS SUPERDECK STAIN, SEMI TRANSPARENT, COLOR: SW 3501 REDWOOD or equal. Pole to be embedded 3' into the ground in roundabout interior.

Low voltage wiring to use direct burial rate 8g wire within 1/2" liquid-tight conduit and watertight grommet to all fixtures. Max 24" exposed wire to fixture. 18" min burial depth. 24v fixtures and transformer provided by landscape architect. Contractor responsible for wiring, conduit, utility/meter coordination, over-current protection (ocp), and installation of fixtures to applicable NFPA70/NEC codes as required.

Pay ItemPay Unit

Landscape Lights.....	Each
Conduit 1" PVC	Linear Foot
Conduit 1.5" PVC	Linear Foot
Low voltage transformer.....	Each
Photocell.....	Each

R-5799

L17

Transylvania County

TIMBER FENCE

This section refers to the custom timber fence sections shown on the landscape plans. The sections are 8' long and shown in the landscape plan details.

Comply with DOC PS 20 and with grading rules of lumber grading agencies certified by ALSC's Board of Review as applicable. If no grading agency is indicated, comply with the applicable rules of any rules-writing agency certified by ALSC's Board of Review.

Factory mark each item with grade stamp of grading agency.

Retain first option in first subparagraph below if authorities having jurisdiction require grade stamps on all materials.

For items that are exposed to view in the completed work, omit grade stamp and provide certificates of grade compliance issued by grading agency.

Provide dressed lumber, S4S, unless otherwise indicated.

Maximum Moisture Content

Dimension Lumber: 19 percent for 2-inch nominal thickness or less; no limit for more than 2-inch nominal thickness.

Boards: Douglas fir, C & Btr finish or C Select; NLGA, WCLIB, or WWPA

Dimension Lumber Posts: **Construction or No. 2** grade of the following species:

Douglas fir-larch, Douglas fir-larch (North), or Douglas fir-south; NLGA, WCLIB, or WWPA.

1.1 PRESERVATIVE TREATMENT

- A. Pressure treat boards and dimension lumber with waterborne preservative according to AWWA U1; Use Category UC3b for exterior construction not in contact with the ground, and Use Category UC4a for items in contact with the ground.
- B. Pressure treat timber with waterborne preservative according to AWWA U1; Use Category UC4a.
 - 1. Treatment with CCA shall include post-treatment fixation process.
- C. Preservative Chemicals: Acceptable to authorities having jurisdiction.
 - 1. Do not use chemicals containing arsenic or chromium.
- D. After treatment, redry dimension lumber to 19 percent maximum moisture content.

PRODUCT DATA SHEET 1 - After installation, stain all timber members with SHERWIN WILLIAMS SUPERDECK STAIN, SEMI TRANSPARENT, COLOR: SW 3501 REDWOOD or equal.

R-5799

L18

Transylvania County

1.1 FASTENERS

- A. General: Provide fasteners of size and type indicated, acceptable to authorities having jurisdiction, and that comply with requirements specified in this article for material and manufacture. Provide nails or screws, in sufficient length, to penetrate not less than 1-1/2 inches into wood substrate.
1. Use fasteners with hot-dip zinc coating complying with ASTM A 153/A 153M or ASTM F 2329 unless otherwise indicated.
 2. For pressure-preservative-treated wood, use stainless-steel fasteners.
- B. Post installed Anchors: Stainless-steel, torque-controlled expansion anchors with capability to sustain, without failure, a load equal to 6 times the load imposed when installed in unit masonry assemblies and equal to 4 times the load imposed when installed in concrete as determined by testing according to ASTM E 488, conducted by a qualified independent testing and inspecting agency.
1. Stainless-steel bolts and nuts complying with ASTM F 593 and ASTM F 594, Alloy Group 1 or 2.

1.2 METAL ACCESSORIES

- A. Galvanized-Steel Sheet: Hot-dip, zinc-coated steel sheet complying with ASTM A 653/A 653M, G60 coating designation.
- B. Stainless-Steel Sheet: ASTM A 666, Type 304.

STEEL AND IRON FINISHES

- A. Powder Coatings, Polyester, meeting performance requirements of AAMA 2604.
1. Product: PPG Industries, Inc., Envirocron 04 Ultra-Durable Powder Coating or equal.
 2. Pencil Hardness, ASTM D 3363: H – 2H.
 3. Salt Spray Resistance, ASTM B 117: 3,000 hours.
 4. Humidity Resistance, ASTM D 2247: 3,000 hours.
 5. Dry Film Thickness, ASTM D 7901: 2.0 mil, minimum thickness.

PART 2 - EXECUTION**2.1 INSTALLATION, GENERAL**

- A. Set work to required levels and lines, with members plumb, true to line, cut, and fitted. Fit work to other construction; scribe and cope as needed for accurate fit.
- B. Framing Standard: Comply with AF&PA WCD1 unless otherwise indicated.
- C. Install metal framing anchors to comply with manufacturer's written instructions.

R-5799

L19

Transylvania County

- D. Do not splice structural members between supports unless otherwise indicated.
 - E. Apply copper naphthenate field treatment to comply with AWPA M4, to cut surfaces of preservative-treated lumber.
 - F. Securely attach exterior rough carpentry work to substrate by anchoring and fastening as indicated, complying with the following:
 - 1. ICC-ES AC70 for power-driven fasteners.
 - 2. "Fastening Schedule" in ICC's International Building Code.
- "Fastener Schedule for Structural Members" and "Alternate Attachments" in ICC's International Residential Code for One- and Two-Family Dwellings.

Pay Item

Pay Unit

Timber Fence Section including fasteners and stain.....	Each
Concrete tube for post holes (8" diameter x 48" depth).....	Each

R-5799

TS-1

Transylvania County

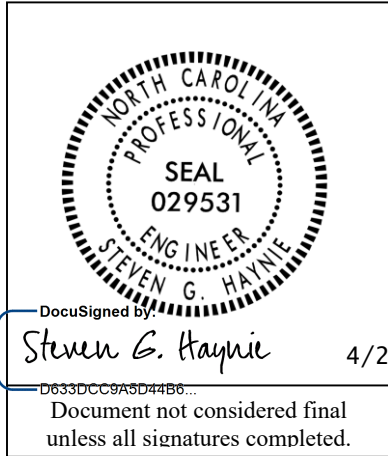

PROJECT SPECIAL PROVISIONS
Intersections of US 64, US 276 and NC 280
Construct Intersection Improvements - Traffic Signals

N.C. Project No. R-5799 (WBS # 44984.1.1)

(Based on NCDOT Signals and Intelligent Transportation Systems Project Special Provisions Version 18.8)

Prepared By: S. Haynie
28-Apr-23

Prepared By:



1520 South Boulevard, Suite 200
Charlotte, NC 28203 NCBEES # F-0493

Contents

1. 2018 STANDARD SPECIFICATIONS FOR ROADS & STRUCTURES.....4

1.1. GENERAL REQUIREMENTS – MATERIALS (1098-1(H))4

1.2. BACKPLATES (1098-2).....4

1.3. GENERAL REQUIREMENTS – CONSTRUCTION METHODS (1700-3(K))4

1.4. GENERAL REQUIREMENTS – CONSTRUCTION METHODS (1700-3(L)).....5

1.5. GENERAL REQUIREMENTS – CONSTRUCTION METHODS (1700-3(M)).....5

1.6. WOOD POLES – CONSTRUCTION METHODS (1720-3)6

1.7. LED BLANKOUT SIGN – DESCRIPTION (1747-1)6

2. SIGNAL HEADS.....6

2.1. MATERIALS6

A. General:6

B. Vehicle Signal Heads:.....8

C. Pedestrian Signal Heads:10

D. Signal Cable:.....11

3. CONTROLLERS WITH CABINETS12

3.1. MATERIALS – TYPE 2070LX CONTROLLERS12

3.2. MATERIALS – GENERAL CABINETS12

3.3. MATERIALS – TYPE 170E CABINETS13

A. Type 170 E Cabinets General:13

B. Type 170 E Cabinet Electrical Requirements:13

C. Type 170 E Cabinet Physical Requirements:.....20

D. Model 2018 Enhanced Conflict Monitor:23

E. Preemption and Sign Control Box33

3.4. MATERIALS – TYPE 170 DETECTOR SENSOR UNITS36

4. CONTROLLERS WITHOUT CABINETS.....36

4.1. MATERIALS – TYPE 2070LX CONTROLLERS36

4.2. MEASUREMENT AND PAYMENT36

5.	PUSH BUTTON INTEGRATED ACCESSIBLE PEDESTRIAN SIGNAL (APS)	36
5.1.	DESCRIPTION	36
5.2.	MATERIALS	36
5.3.	CONSTRUCTION METHODS	38
5.4.	MEASUREMENT AND PAYMENT	38
6.	MICROWAVE VEHICLE DETECTION SYSTEM - MULTIPLE DETECTION ZONES	38
6.1.	DESCRIPTION	38
6.2.	MATERIALS	38
6.3.	CONSTRUCTION METHODS	39
6.4.	MEASUREMENT AND PAYMENT	40
7.	GPS UNIT - GENERIC	40
7.1.	DESCRIPTION	40
7.2.	MATERIALS	40
7.3.	CONSTRUCTION METHODS	40
7.4.	MEASUREMENT AND PAYMENT	40
8.	METAL POLE SUPPORTS	41
8.1.	METAL POLES	41
A.	General:	41
B.	Materials:	42
C.	Design:.....	44
D.	Strain Poles:.....	46
8.2.	DRILLED PIER FOUNDATIONS FOR METAL POLES.....	47
A.	Description:	47
B.	Soil Test and Foundation Determination:	48
C.	Drilled Pier Construction:.....	50
8.3.	METAL POLE REMOVALS.....	50
A.	Description:	50
B.	Construction Methods:.....	50
8.4.	POLE NUMBERING SYSTEM	51
A.	New Poles	51
8.5.	MEASUREMENT AND PAYMENT	51
9.	PROTECTIVE COATING FOR METAL POLES	52
9.1.	DESCRIPTION	52
9.2.	MATERIALS	52
9.3.	COATING SHOP APPROVAL	52
9.4.	POWDER COATING	53
A.	Galvanizing.....	53
B.	Surface Preparation.....	53
C.	Powder Coating Application and Curing.....	54
D.	Quality Control	54
E.	Storage, Shipping, and Handling	54
F.	Repair of Powder Coated Material	54
9.5.	ACRYLIC PRIMER AND TOPCOAT PAINT SYSTEM	54
A.	Description.....	54
B.	Surface Preparation.....	55
C.	Materials	56
D.	Painting.....	56
E.	Curing	56
F.	Inspection.....	56
G.	Handling	57
H.	Repair of Damaged Coating	57
9.6.	MEASUREMENT AND PAYMENT	57

R-5799

TS-3

Transylvania County

10. RECTANGULAR RAPID FLASHING BEACON SOLAR POWERED DISPLAY AND CONTROLLER ASSEMBLY57

- 10.1. DESCRIPTION 57
- 10.2. MATERIALS 58
- 10.3. CONSTRUCTION METHODS 59
- 10.4. MEASUREMENT AND PAYMENT 59

11. CELLULAR MODEMS FOR COMMUNICATIONS.....60

- 11.1. DESCRIPTION 60
- 11.2. MATERIALS 60
 - A. Obtaining Cellular Modem: 60
 - B. Cellular Modem Antenna Mounting Bracket: 60
- 11.3. CONSTRUCTION METHODS 60
 - A. Cellular Modem:..... 60
 - B. Cellular Modem Antenna Mounting Bracket: 60
- 11.4. MEASUREMENT AND PAYMENT 61

1. 2018 STANDARD SPECIFICATIONS FOR ROADS & STRUCTURES

The 2018 Standard Specifications are revised as follows:

1.1. GENERAL REQUIREMENTS – Materials (1098-1(H))

Page 10-212, line 12, revise title of section 1098-1(H) from “Electrical Service” to “Electrical Service for Traffic Signals”.

Page 10-212, revise paragraph beginning on line 13 to read “Furnish external electrical service disconnects with a single pole 50 ampere inverse time circuit breaker with at least 10,000 RMS symmetrical amperes short circuit current rating in a lockable NEMA 3R enclosure. For electrical service to an Advanced Transportation Controller (ATC) cabinet, provide a single pole 30 ampere inverse time circuit breaker with at least 10,000 RMS symmetrical amperes short circuit current rating. Ensure service disconnects are listed as meeting UL Standard UL-489 and marked as being suitable for use as service equipment. Fabricate enclosure from galvanized steel and electrostatically apply dry powder paint finish, light gray in color, to yield a minimum thickness of 2.4 mils. Provide ground bus and neutral bus with at least 5 terminals with minimum wire capacity range of number 14 through number 4. Ensure each service has only one disconnecting means in the enclosure. Place barriers in service equipment such that no uninsulated, ungrounded service busbar, or service terminal is exposed.”

1.2. BACKPLATES (1098-2)

Page 10-213, revise paragraph starting on line 27 to read:

“Provide polycarbonate or vacuum formed ABS plastic or composite material backplates that are black on both the front and back sides with a consistent color throughout the entire piece for each backplate. Provide backplates that contain UV inhibitors and stabilizers for protection against UV degradation. Provide backplates that have a minimum tensile stress at yield of 5,300 psi at 73°F and meet UL Standard 94. Ensure polycarbonate backplates have a minimum thickness of 0.100 inch with one side dull black and the other side semi-gloss black. Ensure vacuum formed ABS plastic backplates have a minimum thickness of 0.125 inch with a hair cell finish on the front side and a smooth finish on the back side. Ensure composite material backplates have a polyethylene core with a minimum thickness of 0.074 inch surrounded by 2 aluminum sheets with each aluminum sheet at a minimum of 0.010 inch. Ensure the 2 aluminum sheets and the polyethylene core are bonded together with fluoropolymer or polyester coating on both outer sides for the composite material backplates.”

Page 10-213, add the following after line 34:

“Provide backplates with a florescent yellow retroreflective sheeting strip 2 inches wide, placed along the perimeter of the face of the signal backplate to reflect the profile of the signal head in low-light and darkness. Ensure connecting corner sections of the retroreflective sheeting strips are butt spliced with a minimum gap of 30 mil to a maximum gap of 45 mil. The sheeting strip shall meet the performance requirements of AASHTO M268 Type D and ASTM D4956 Type X1 sheeting material.” Ensure the retroreflective sheeting strip is applied in accordance with manufacturer’s guidelines.

1.3. GENERAL REQUIREMENTS – Construction Methods (1700-3(K))

Page 17-4, revise paragraph starting on line 10 to read:

“Where electrical services do not include an external electrical service disconnect, modify service to include electrical service disconnect and a new grounding electrode system.

Provide a grounding electrode system at all new electrical services. All grounding and bonding equipment shall conform to UL Standard 467. Permanently bond grounding conductor to ground rod using an irreversible ground connector. Unless the irreversible ground connectors are designed for use with more than one conductor, only one conductor shall be used with each irreversible ground connector. Ensure all irreversible ground connectors are installed per manufacturer's installation instructions. Irreversible compression ground connectors requiring the use of a die for installation shall be made using a hydraulic, power, or ratcheting type crimper with appropriate dies. The use of handheld pliers for crimping irreversible compression ground connectors is prohibited.

Modify existing electrical services, as necessary, to meet the grounding requirements of the NEC, these Standard Specifications and the project plans. Remove any ground rods in the cabinet foundation and install a new grounding electrode system. Cut off abandoned ground rods in the cabinet foundation flush with the foundation surface.

In addition to NEC requirements, test grounding electrode resistance for a maximum of 20 ohms. Furnish and install additional ground rods to grounding electrode system as necessary to meet the Standard Specifications, Standard Drawings, and test requirements. Grounding electrode resistance test shall be verified or witnessed by the Engineer or the Engineer's designated representative.

Follow test equipment's procedures for measuring grounding electrode resistance. When using clamp-type ground resistance meters, readings of less than one ohm typically indicate a ground loop. Rework bonding and grounding circuits as necessary to remove ground loop circuits and retest. If a ground loop cannot be identified and removed to allow the proper use of a clamp-type ground resistance meter, use the three-point test method.

Submit a completed Inductive Loop & Grounding Test Form available on the Department's website.

For ease of inspection, the top of ground rods shall be 12 inches (± 1 inch) below finished grade and shall remain exposed until electrical inspection is complete. Provide a length of marker tape 6 inches below finished grade directly over grounding electrodes and conductors.

For ground rods installed in areas where the slope is greater than 4:1, the top of the ground rods shall be a minimum of 24" below finished grade. Provide a length of marker tape 6 inches to 12 inches below finished grade directly over grounding electrodes and conductors."

1.4. GENERAL REQUIREMENTS – Construction Methods (1700-3(L))

Page 17-4, revise paragraph starting on line 35 to read "Using an approved termination means, connect a #14 AWG minimum, 19-strand copper conductor (Type THWN) with insulation that is green or green with one or more yellow stripes to serve as an equipment grounding conductor to metal poles, vehicular and pedestrian signal pedestals, and other metallic components which are not otherwise bonded through means approved by the Engineer. For traffic signal installations, equipment grounding conductors shall have insulation that is green with one or more yellow stripes."

1.5. GENERAL REQUIREMENTS – Construction Methods (1700-3(M))

Page 17-4, Replace the sentence beginning on line 41 with "Prior to placing signal in the steady (stop-and-go) mode, the signal should be placed in the flashing mode for up to 7 days or as directed by the Engineer. The signal should not be placed in the steady (stop-and-go) mode on a Saturday or Sunday without prior approval from the Engineer. Do not place the signal in steady (stop-and-go) mode until inspected and without the prior approval of the Engineer."

1.6. WOOD POLES – Construction Methods (1720-3)

Page 17-18, revise sentence starting on line 13 to read “On new Department-owned poles, install a grounding system consisting of #6 AWG solid bare copper wire that is connected with an **irreversible ground connector** to a single ground rod installed at base of pole or to the electrical service grounding electrode system located within 10 feet of the pole.”

1.7. LED BLANKOUT SIGN – Description (1747-1)

Page 17-36, revise paragraph starting on line 14 to read:

“Furnish and install Light Emitting Diode (LED) blankout signs with all necessary hardware as set forth in the plans and specifications. Fabricate the sign such that the legend elements, text size, font type, and overall size of the sign comply with the applicable provisions for the static version of the sign found in the latest version of the MUTCD.”

2. SIGNAL HEADS

2.1. MATERIALS

A. General:

Fabricate vehicle signal head housings and end caps from die-cast aluminum. Fabricate 12-inch and 16-inch pedestrian signal head housings and end caps from die-cast aluminum. Fabricate 9-inch pedestrian signal head housings, end caps, and visors from virgin polycarbonate material. Provide visor mounting screws, door latches, and hinge pins fabricated from stainless steel. Provide interior screws, fasteners, and metal parts fabricated from stainless steel.

Fabricate tunnel and traditional visors from sheet aluminum.

Paint all surfaces inside and outside of signal housings and doors. Paint outside surfaces of tunnel and traditional visors, wire outlet bodies, wire entrance fitting brackets and end caps when supplied as components of messenger cable mounting assemblies, pole and pedestal mounting assemblies, and pedestrian pushbutton housings. Have electrostatically-applied, fused-polyester paint in highway yellow (Federal Standard 595C, Color Chip Number 13538) a minimum of 2.5 to 3.5 mils thick. Do not apply paint to the latching hardware, rigid vehicle signal head mounting brackets for mast-arm attachments, messenger cable hanger components or balance adjuster components.

Have the interior surfaces of tunnel and traditional visors painted an alkyd urea black synthetic baking enamel with a minimum gloss reflectance and meeting the requirements of MIL-E-10169, “Enamel Heat Resisting, Instrument Black.”

Where required, provide polycarbonate signal heads and visors that comply with the provisions pertaining to the aluminum signal heads listed on the QPL with the following exceptions:

Fabricate signal head housings, end caps, and visors from virgin polycarbonate material. Provide UV stabilized polycarbonate plastic with a minimum thickness of 0.1 ± 0.01 inches that is highway yellow (Federal Standard 595C, Color Chip 13538). Ensure the color is incorporated into the plastic material before molding the signal head housings and end caps. Ensure the plastic formulation provides the following physical properties in the assembly (tests may be performed on separately molded specimens):

R-5799**TS-7****Transylvania County**

Test	Required	Method
Specific Gravity	1.17 minimum	ASTM D 792
Flammability	Self-extinguishing	ASTM D 635
Tensile Strength, yield, PSI	8500 minimum	ASTM D 638
Izod impact strength, ft-lb/in [notched, 1/8 inch]	12 minimum	ASTM D 256

For pole mounting, provide side of pole mounting assemblies with framework and all other hardware necessary to make complete, watertight connections of the signal heads to the poles and pedestals. Fabricate the mounting assemblies and frames from aluminum with all necessary hardware, screws, washers, etc. to be stainless steel. Provide mounting fittings that match the positive locking device on the signal head with the serrations integrally cast into the brackets. Provide upper and lower pole plates that have a 1 ¼-inch vertical conduit entrance hubs with the hubs capped on the lower plate and 1 ½-inch horizontal hubs. Ensure that the assemblies provide rigid attachments to poles and pedestals so as to allow no twisting or swaying of the signal heads. Ensure that all raceways are free of sharp edges and protrusions, and can accommodate a minimum of ten Number 14 AWG conductors.

For pedestal mounting, provide a post-top slipfitter mounting assembly that matches the positive locking device on the signal head with serrations integrally cast into the slipfitter. Provide stainless steel hardware, screws, washers, etc. Provide a minimum of six 3/8 X 3/4-inch long square head bolts for attachment to pedestal. Provide a center post for multi-way slipfitters.

For light emitting diode (LED) traffic signal modules, provide the following requirements for inclusion on the Department's Qualified Products List for traffic signal equipment.

1. Sample submittal,
2. Third-party independent laboratory testing results for each submitted module with evidence of testing and conformance with all of the Design Qualification Testing specified in section 6.4 of each of the following Institute of Transportation Engineers (ITE) specifications:
 - Vehicle Traffic Control Signal Heads – Light Emitting Diode (LED) Circular Signal Supplement
 - Vehicle Traffic Control Signal Heads – Light Emitting Diode (LED) Vehicle Arrow Traffic Signal Supplement
 - Pedestrian Traffic Control Signal Indications –Light Emitting Diode (LED) Signal Modules.

(Note: The Department currently recognizes two approved independent testing laboratories. They are Intertek ETL Semko and Light Metrics, Incorporated with Garwood Laboratories. Independent laboratory tests from other laboratories may be considered as part of the QPL submittal at the discretion of the Department,

3. Evidence of conformance with the requirements of these specifications,
4. A manufacturer's warranty statement in accordance with the required warranty, and
5. Submittal of manufacturer's design and production documentation for the model, including but not limited to, electrical schematics, electronic component values, proprietary part numbers, bill of materials, and production electrical and photometric test parameters.
6. Evidence of approval of the product to bear the Intertek ETL Verified product label for LED traffic signal modules.

Ensure LED traffic signal modules meet the performance requirements for the minimum period of 15 years, provide a written warranty against defects in materials and workmanship for the modules for a period of 15 years after installation of the modules. During the warranty period, the manufacturer must provide new replacement modules within 45 days of receipt of modules that have failed at no cost to the State. Repaired or refurbished modules may not be used to fulfill the manufacturer's warranty obligations. Provide manufacturer's warranty documentation to the Department during evaluation of product for inclusion on Qualified Products List (QPL).

B. Vehicle Signal Heads:

Comply with the ITE standard "Vehicle Traffic Control Signal Heads". Provide housings with provisions for attaching backplates.

Provide visors that are 8 inches in length for 8-inch vehicle signal head sections. Provide visors that are 10 inches in length for 12-inch vehicle signal heads.

Provide a termination block with one empty terminal for field wiring for each indication plus one empty terminal for the neutral conductor. Have all signal sections wired to the termination block. Provide barriers between the terminals that have terminal screws with a minimum Number 8 thread size and that will accommodate and secure spade lugs sized for a Number 10 terminal screw.

Mount termination blocks in the yellow signal head sections on all in-line vehicle signal heads. Mount the termination block in the red section on five-section vehicle signal heads.

Furnish vehicle signal head interconnecting brackets. Provide one-piece aluminum brackets less than 4.5 inches in height and with no threaded pipe connections. Provide hand holes on the bottom of the brackets to aid in installing wires to the signal heads. Lower brackets that carry no wires and are used only for connecting the bottom signal sections together may be flat in construction.

For messenger cable mounting, provide messenger cable hangers, wire outlet bodies, balance adjusters, bottom caps, wire entrance fitting brackets, and all other hardware necessary to make complete, watertight connections of the vehicle signal heads to the messenger cable. Fabricate messenger cable hanger components, wire outlet bodies and balance adjuster components from stainless steel or malleable iron galvanized in accordance with ASTM A153 (Class A) or ASTM A123. Provide serrated rings made of aluminum. Provide messenger cable hangers with U-bolt clamps. Fabricate washers, screws, hex-head bolts and associated nuts, clevis pins, cotter pins, U-bolt clamps and nuts from stainless steel.

For mast-arm mounting, provide rigid vehicle signal head mounting brackets and all other hardware necessary to make complete, watertight connections of the vehicle signal heads to the mast arms and to provide a means for vertically adjusting the vehicle signal heads to proper alignment. Fabricate the mounting assemblies from aluminum, and provide serrated rings made of aluminum. Provide stainless steel cable attachment assemblies to secure the brackets to the mast arms. Ensure all fastening hardware and fasteners are fabricated from stainless steel.

Provide LED vehicular traffic signal modules (hereafter referred to as modules) that consist of an assembly that uses LEDs as the light source in lieu of an incandescent lamp for use in traffic signal sections. Use LEDs that are aluminum indium gallium phosphorus (AlInGaP) technology for red and yellow indications and indium gallium nitride (InGaN) for green indications. Install the ultra bright type LEDs that are rated for 100,000 hours of continuous operation from -40°F to +165°F. Design modules to have a minimum useful life of 15 years and to meet all parameters of this specification during this period of useful life.

R-5799**TS-9****Transylvania County**

For the modules, provide spade terminals crimped to the lead wires and sized for a #10 screw connection to the existing terminal block in a standard signal head. Do not provide other types of crimped terminals with a spade adapter.

Ensure the power supply is integral to the module assembly. On the back of the module, permanently mark the date of manufacture (month & year) or some other method of identifying date of manufacture.

Tint the red, yellow and green lenses to correspond with the wavelength (chromaticity) of the LED. Transparent tinting films are unacceptable. Provide a lens that is integral to the unit with a smooth outer surface.

1. LED Circular Signal Modules:

Provide modules in the following configurations: 12-inch circular sections, and 8-inch circular sections. All makes and models of LED modules purchased for use on the State Highway System shall appear on the current NCDOT Traffic Signal Qualified Products List (QPL).

Provide the manufacturer's model number and the product number (assigned by the Department) for each module that appears on the 2018 or most recent Qualified Products List. In addition, provide manufacturer's certification in accordance with Article 106-3 of the *Standard Specifications*, that each module meets or exceeds the ITE "Vehicle Traffic Control Signal Heads – Light Emitting Diode (LED) Circular Signal Supplement" dated June 27, 2005 (hereafter referred to as VTCSH Circular Supplement) and other requirements stated in this specification.

Provide modules that meet the following requirements when tested under the procedures outlined in the VTCSH Circular Supplement:

Module Type	Max. Wattage at 165° F	Nominal Wattage at 77° F
12-inch red circular	17	11
12-inch green circular	15	15

For yellow circular signal modules, provide modules tested under the procedures outlined in the VTCSH Circular Supplement to insure power required at 77° F is 22 Watts or less for the 12-inch circular module and 13 Watts or less for the 8-inch circular module.

Note: Use a wattmeter having an accuracy of $\pm 1\%$ to measure the nominal wattage and maximum wattage of a circular traffic signal module. Power may also be derived from voltage, current and power factor measurements.

2. LED Arrow Signal Modules

Provide 12-inch omnidirectional arrow signal modules. All makes and models of LED modules purchased for use on the State Highway System shall appear on the current NCDOT Traffic Signal Qualified Products List (QPL).

Provide the manufacturer's model number and the product number (assigned by the Department) for each module that appears on the 2018 or most recent Qualified Products List. In addition, provide manufacturer's certification in accordance with Article 106-3 of the *Standard Specifications*, that each module meets or exceeds the requirements for 12-inch omnidirectional modules specified in the ITE "Vehicle Traffic Control Signal Heads – Light Emitting Diode (LED) Vehicle Arrow Traffic Signal Supplement" dated July 1, 2007 (hereafter referred to as VTCSH Arrow Supplement) and other requirements stated in this specification.

Provide modules that meet the following requirements when tested under the procedures outlined in the VTCSH Arrow Supplement:

Module Type	Max. Wattage at 165° F	Nominal Wattage at 77° F
12-inch red arrow	12	9
12-inch green arrow	11	11

For yellow arrow signal modules, provide modules tested under the procedures outlined in the VTCSH Arrow Supplement to insure power required at 77° F is 12 Watts or less.

Note: Use a wattmeter having an accuracy of $\pm 1\%$ to measure the nominal wattage and maximum wattage of an arrow traffic signal module. Power may also be derived from voltage, current and power factor measurements.

C. Pedestrian Signal Heads:

Provide pedestrian signal heads with international symbols that meet the MUTCD. Do not provide letter indications.

Comply with the ITE standard for “Pedestrian Traffic Control Signal Indications” and the following sections of the ITE standard for “Vehicle Traffic Control Signal Heads” in effect on the date of advertisement:

- Section 3.00 - “Physical and Mechanical Requirements”
- Section 4.01 - “Housing, Door, and Visor: General”
- Section 4.04 - “Housing, Door, and Visor: Materials and Fabrication”
- Section 7.00 - “Exterior Finish”

Provide a double-row termination block with three empty terminals and number 10 screws for field wiring. Provide barriers between the terminals that accommodate a spade lug sized for number 10 terminal screws. Mount the termination block in the hand section. Wire all signal sections to the terminal block.

Where required by the plans, provide 16-inch pedestrian signal heads with traditional three-sided, rectangular visors, 6 inches long. Where required by the plans, provide 12-inch pedestrian signal heads with traditional three-sided, rectangular visors, 8 inches long.

Provide 2-inch diameter pedestrian push-buttons with weather-tight housings fabricated from die-cast aluminum and threading in compliance with the NEC for rigid metal conduit. Provide a weep hole in the housing bottom and ensure that the unit is vandal resistant.

Provide push-button housings that are suitable for mounting on flat or curved surfaces and that will accept 1/2-inch conduit installed in the top. Provide units that have a heavy duty push-button assembly with a sturdy, momentary, normally-open switch. Have contacts that are electrically insulated from the housing and push-button. Ensure that the push-buttons are rated for a minimum of 5 mA at 24 volts DC and 250 mA at 12 volts AC.

Provide standard R10-3 signs with mounting hardware that comply with the MUTCD in effect on the date of advertisement. Provide R10-3E signs for countdown pedestrian heads and R10-3B for non-countdown pedestrian heads.

Design the LED pedestrian traffic signal modules (hereafter referred to as modules) for installation into standard pedestrian traffic signal sections that do not contain the incandescent signal section reflector, lens, eggcrate visor, gasket, or socket. Provide modules that consist of an assembly that uses LEDs as the light source in lieu of an incandescent lamp. Use LEDs that are of the latest aluminum indium gallium phosphorus (AlInGaP) technology for the Portland Orange hand and countdown displays. Use LEDs that are of the latest indium gallium nitride (InGaN) technology for the Lunar White walking man displays. Install the ultra-bright type LEDs that are rated for 100,000

R-5799**TS-11****Transylvania County**

hours of continuous operation from -40°F to +165°F. Design modules to have a minimum useful life of 60 months and to meet all parameters of this specification during this period of useful life.

Design all modules to operate using a standard 3 - wire field installation. Provide spade terminals crimped to the lead wires and sized for a #10 screw connection to the existing terminal block in a standard pedestrian signal housing. Do not provide other types of crimped terminals with a spade adapter.

Ensure the power supply is integral to the module assembly. On the back of the module, permanently mark the date of manufacture (month & year) or some other method of identifying date of manufacture.

Provide modules in the following configuration: 16-inch displays which have the solid hand/walking man overlay on the left and the countdown on the right, and 12-inch displays which have the solid hand/walking man module as an overlay. All makes and models of LED modules purchased for use on the State Highway System shall appear on the current NCDOT Traffic Signal Qualified Products List (QPL).

Provide the manufacturer's model number and the product number (assigned by the Department) for each module that appears on the 2018 or most recent Qualified Products List. In addition, provide manufacturer's certification in accordance with Article 106-3 of the *Standard Specifications*, that each module meets or exceeds the ITE "Pedestrian Traffic Control Signal Indicators - Light Emitting Diode (LED) Signal Modules" dated August 04, 2010 (hereafter referred to as PTCSI Pedestrian Standard) and other requirements stated in this specification.

Provide modules that meet the following requirements when tested under the procedures outlined in the PTCSI Pedestrian Standard:

Module Type	Max. Wattage at 165° F	Nominal Wattage at 77° F
Hand Indication	16	13
Walking Man Indication	12	9
Countdown Indication	16	13

Note: Use a wattmeter having an accuracy of $\pm 1\%$ to measure the nominal wattage and maximum wattage of a circular traffic signal module. Power may also be derived from voltage, current and power factor measurements.

Provide module lens that is hard coated or otherwise made to comply with the material exposure and weathering effects requirements of the Society of Automotive Engineers (SAE) J576. Ensure all exposed components of the module are suitable for prolonged exposure to the environment, without appreciable degradation that would interfere with function or appearance.

Ensure the countdown display continuously monitors the traffic controller to automatically learn the pedestrian phase time and update for subsequent changes to the pedestrian phase time.

Ensure the countdown display begins normal operation upon the completion of the preemption sequence and no more than one pedestrian clearance cycle.

D. Signal Cable:

Furnish 16-4 and 16-7 signal cable that complies with IMSA specification 20-1 except provide the following conductor insulation colors:

- For 16-4 cable: white, yellow, red, and green

R-5799**TS-12****Transylvania County**

- For 16-7 cable: white, yellow, red, green, yellow with black stripe tracer, red with black stripe tracer, and green with black stripe tracer. Apply continuous stripe tracer on conductor insulation with a longitudinal or spiral pattern.

Provide a ripcord to allow the cable jacket to be opened without using a cutter. IMSA specification 19-1 will not be acceptable. Provide a cable jacket labeled with the IMSA specification number and provide conductors constructed of stranded copper.

3. CONTROLLERS WITH CABINETS

3.1. MATERIALS – TYPE 2070LX CONTROLLERS

Furnish model 2070LX controller units that conform to CALTRANS *Transportation Electrical Equipment Specifications* (TEES) (dated March 12, 2009, plus Errata 1 dated January 21, 2010 and Errata 2 dated December 5, 2014) except as required herein.

The Department will provide software at the beginning of the burning-in period. Contractor shall give 5 working days notice before needing software. Program software provided by the Department.

Provide model 2070LX controllers with Linux kernel 2.6.18 or higher and device drivers, composed of the unit chassis and at a minimum the following modules and assemblies:

- MODEL 2070-1C, CPU Module, Single Board, with 8Mb Datakey (blue in color)
- MODEL 2070-2E+, Field I/O Module (FI/O)
 - Note: Configure the Field I/O Module to disable both the External WDT Shunt/Toggle Switch and SP3 (SP3 active indicator is “off”)
- MODEL 2070-3B, Front Panel Module (FP), Display B (8x40)
- MODEL 2070-4A, Power Supply Module, 10 AMP

Provide a Board Support Package (BSP) to the state and to any specified applications software manufacturer when requested by the state to facilitate the porting of application software.

3.2. MATERIALS – GENERAL CABINETS

Provide a moisture resistant coating on all circuit boards.

Provide one 20 mm diameter radial lead UL-recognized metal oxide varistor (MOV) between each load switch field terminal and equipment ground. Electrical performance is outlined below.

PROPERTIES OF MOV SURGE PROTECTOR	
Maximum Continuous Applied Voltage at 185° F	150 VAC (RMS) 200 VDC
Maximum Peak 8x20µs Current at 185° F	6500 A
Maximum Energy Rating at 185° F	80 J
Voltage Range 1 mA DC Test at 77° F	212-268 V
Max. Clamping Voltage 8x20µs, 100A at 77° F	395 V
Typical Capacitance (1 MHz) at 77° F	1600 pF

R-5799**TS-13****Transylvania County**

Provide a power line surge protector that is a two-stage device that will allow connection of the radio frequency interference filter between the stages of the device. Ensure that a maximum continuous current is at least 10A at 120V. Ensure that the device can withstand a minimum of 20 peak surge current occurrences at 20,000A for an 8x20 microsecond waveform. Provide a maximum clamp voltage of 395V at 20,000A with a nominal series inductance of 200 μ h. Ensure that the voltage does not exceed 395V. Provide devices that comply with the following:

Frequency (Hz)	Minimum Insertion Loss (dB)
60	0
10,000	30
50,000	55
100,000	50
500,000	50
2,000,000	60
5,000,000	40
10,000,000	20
20,000,000	25

3.3. MATERIALS – TYPE 170E CABINETS

A. Type 170 E Cabinets General:

Conform to the city of Los Angeles' Specification No. 54-053-08, *Traffic Signal Cabinet Assembly Specification* (dated July 2008), except as required herein.

Furnish model 336S pole mounted cabinets configured for 8 vehicle phases, 4 pedestrian phases, and 6 overlaps. Do not reassign load switches to accommodate overlaps unless shown on electrical details. Provide 336S pole mounted cabinets that are 46" high with 40" high internal rack assemblies.

Furnish model 332 base mounted cabinets configured for 8 vehicle phases, 4 pedestrian phases, and 6 overlaps. When overlaps are required, provide auxiliary output files for the overlaps. Do not reassign load switches to accommodate overlaps unless shown on electrical details.

Provide model 200 load switches, model 222 loop detector sensors, model 252 AC isolators, and model 242 DC isolators according to the electrical details. As a minimum, provide one (1) model 2018 conflict monitor, one (1) model 206L power supply unit, two (2) model 204 flashers, one (1) DC isolator (located in slot I14), and four (4) model 430 flash transfer relays (provide seven (7) model 430 flash transfer relays if auxiliary output file is installed) with each cabinet.

B. Type 170 E Cabinet Electrical Requirements:

Provide a cabinet assembly designed to ensure that upon leaving any cabinet switch or conflict monitor initiated flashing operation, the controller starts up in the programmed start up phases and start up interval.

Furnish two sets of non-fading cabinet wiring diagrams and schematics in a paper envelope or container and placed in the cabinet drawer.

All AC+ power is subject to radio frequency signal suppression.

Provide surge suppression in the cabinet for each type of cabinet device. Provide surge protection for the full capacity of the cabinet input file. Provide surge suppression devices that operate properly over a temperature range of -40° F to +185° F. Ensure the surge suppression devices provide both common and differential modes of protection.

Provide a pluggable power line surge protector that is installed on the back of the PDA (power distribution assembly) chassis to filter and absorb power line noise and switching transients. Ensure the device incorporates LEDs for failure indication and provides a dry relay contact closure for the purpose of remote sensing. Ensure the device meets the following specifications:

Peak Surge Current (Single pulse, 8x20µs).....	20,000A
Occurrences (8x20µs waveform).....	10 minimum @ 20,000A
Maximum Clamp Voltage.....	395VAC
Operating Current.....	15 amps
Response Time.....	< 5 nanoseconds

Provide a loop surge suppressor for each set of loop terminals in the cabinet. Ensure the device meets the following specifications:

Peak Surge Current (6 times, 8x20µs)	
(Differential Mode).....	400A
(Common Mode).....	1,000A
Occurrences (8x20µs waveform).....	500 min @ 200A
Maximum Clamp Voltage	
(Differential Mode @400A).....	35V
(Common Mode @1,000A).....	35V
Response Time.....	< 5 nanoseconds
Maximum Capacitance.....	35 pF

Provide a data communications surge suppressor for each communications line entering or leaving the cabinet. Ensure the device meets the following specifications:

Peak Surge Current (Single pulse, 8x20µs).....	10,000A
Occurrences (8x20µs waveform).....	100 min @ 2,000A
Maximum Clamp Voltage.....	Rated for equipment protected
Response Time.....	< 1 nanosecond
Maximum Capacitance.....	1,500 pF
Maximum Series Resistance.....	15Ω

Provide a DC signal surge suppressor for each DC input channel in the cabinet. Ensure the device meets the following specifications:

Peak Surge Current (Single pulse, 8x20µs).....10,000A
 Occurrences (8x20µs waveform).....100 @ 2,000A
 Maximum Clamp Voltage.....30V
 Response Time.....< 1 nanosecond

Provide a 120 VAC signal surge suppressor for each AC+ interconnect signal input. Ensure the device meets the following specifications:

Peak Surge Current (Single pulse, 8x20µs).....20,000A
 Maximum Clamp Voltage.....350VAC
 Response Time.....< 200 nanoseconds
 Discharge Voltage.....<200 Volts @ 1,000A
 Insulation Resistance.....≥100 MΩ

Provide conductors for surge protection wiring that are of sufficient size (ampacity) to withstand maximum overcurrents which could occur before protective device thresholds are attained and current flow is interrupted.

If additional surge protected power outlets are needed to accommodate fiber transceivers, modems, etc., install a UL listed, industrial, heavy-duty type power outlet strip with a minimum rating of 15 A / 125 VAC, 60 Hz. Provide a strip that has a minimum of 3 grounded outlets. Ensure the power outlet strip plugs into one of the controller unit receptacles located on the rear of the PDA. Ensure power outlet strip is mounted securely; provide strain relief if necessary.

Provide a door switch in the front and a door switch in the rear of the cabinet that will provide the controller unit with a Door Ajar alarm when either the front or the rear door is open. Ensure the door switches apply DC ground to the Input File when either the front door or the rear door is open.

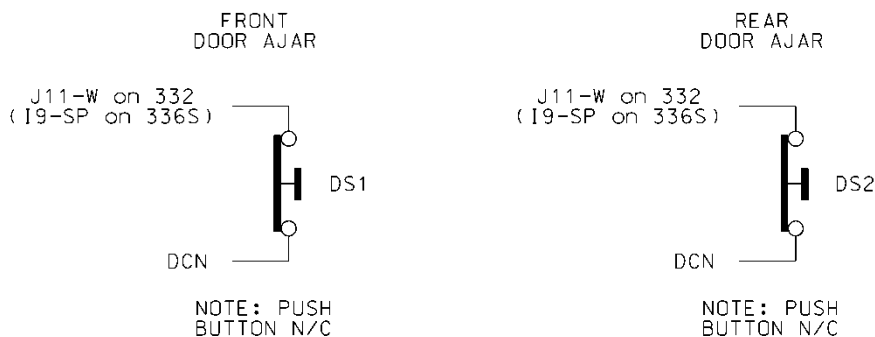

Furnish a fluorescent fixture in the rear across the top of the cabinet and another fluorescent fixture in the front across the top of the cabinet at a minimum. Ensure that the fixtures provide sufficient light to illuminate all terminals, labels, switches, and devices in the cabinet. Conveniently locate the fixtures so as not to interfere with a technician’s ability to perform work on any devices or terminals in the cabinet. Provide a protective diffuser to cover exposed bulbs. Install 16 watt T-4 lamps in the fluorescent fixtures. Provide a door switch to provide power to each fixture when the

R-5799**TS-16****Transylvania County**

respective door is open. Wire the fluorescent fixtures to the 15 amp ECB (equipment circuit breaker).

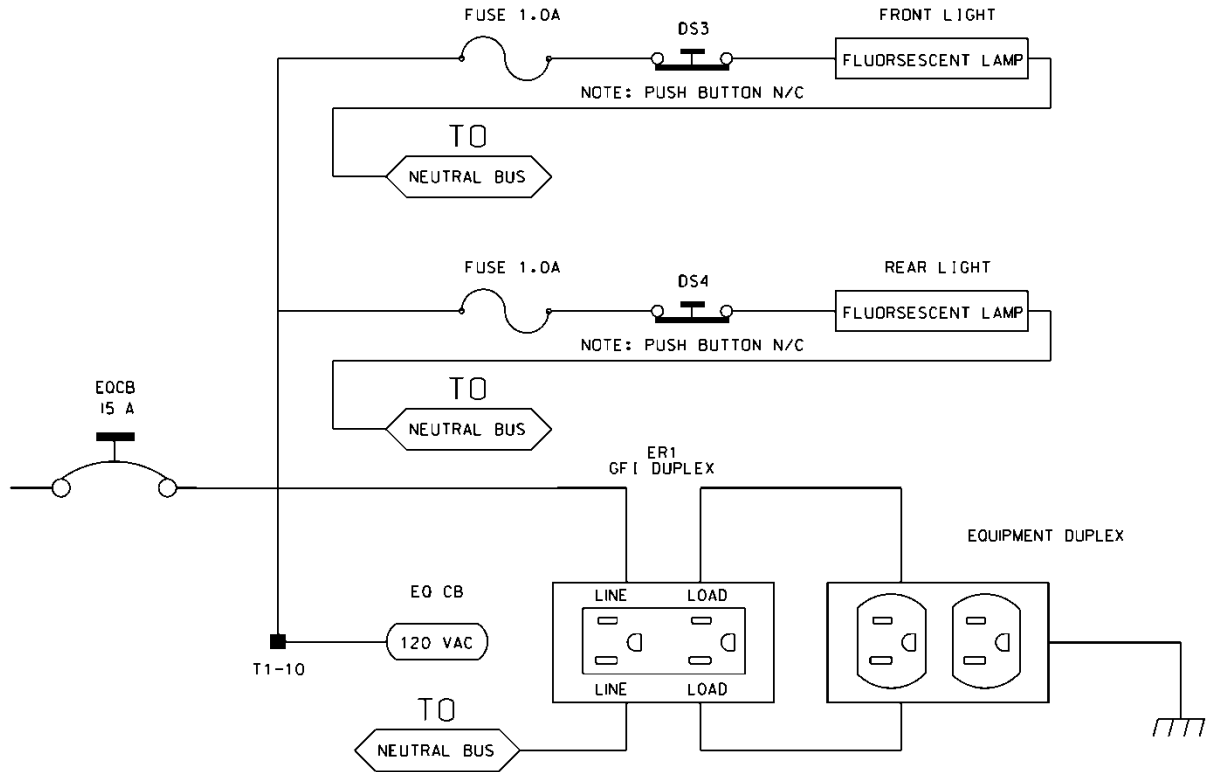

Furnish a police panel with a police panel door. For model 336S cabinets, mount the police panel on the rear door. Ensure that the police panel door permits access to the police panel when the main door is closed. Ensure that no rainwater can enter the cabinet even with the police panel door open. Provide a police panel door hinged on the right side as viewed from the front. Provide a police panel door lock that is keyed to a standard police/fire call box key. In addition to the requirements of LA Specification No. 54-053-08, provide the police panel with a toggle switch connected to switch the intersection operation between normal stop-and-go operation (AUTO) and manual operation (MANUAL). Ensure that manual control can be implemented using inputs and software such that the controller provides full programmed clearance times for the yellow clearance and red clearance for each phase while under manual control.

Provide a 1/4-inch locking phone jack in the police panel for a hand control to manually control the intersection. Provide sufficient room in the police panel for storage of a hand control and cord.

Ensure the 336S cabinet Input File is wired as follows:

R-5799

TS-17

Transylvania County

336S Cabinet														
Port-Bit/C-1 Pin Assignment														
Slot #	1	2	3	4	5	6	7	8	9	10	11	12	13	14
C-1 (Spares)	59	60	61	62	63	64	65	66	75	76	77	78	79	80
Port C-1	3-2 56	1-1 39	3-4 58	1-3 41	3-1 55	1-2 40	3-3 57	1-4 42	2-5 51	5-5 71	5-6 72	5-1 67	5-2 68	6-7 81
Port C-1	2-1 47	1-5 43	2-3 49	1-7 45	2-2 48	1-6 44	2-4 50	1-8 46	2-6 52	5-7 73	5-8 74	5-3 69	5-4 70	6-8 82

For model 332 base mounted cabinets, ensure terminals J14-E and J14-K are wired together on the rear of the Input File. Connect TB9-12 (J14 Common) on the Input Panel to T1-2 (AC-) on the rear of the PDA.

Provide detector test switches mounted at the top of the cabinet rack or other convenient location which may be used to place a call on each of eight phases based on the chart below. Provide three positions for each switch: On (place call), Off (normal detector operation), and Momentary On (place momentary call and return to normal detector operation after switch is released). Ensure that the switches are located such that the technician can read the controller display and observe the intersection.

Connect detector test switches for cabinets as follows:

336S Cabinet		332 Cabinet	
Detector Call Switches	Terminals	Detector Call Switches	Terminals
Phase 1	I1-F	Phase 1	I1-W
Phase 2	I2-F	Phase 2	I4-W
Phase 3	I3-F	Phase 3	I5-W
Phase 4	I4-F	Phase 4	I8-W
Phase 5	I5-F	Phase 5	J1-W
Phase 6	I6-F	Phase 6	J4-W
Phase 7	I7-F	Phase 7	J5-W
Phase 8	I8-F	Phase 8	J8-W

Provide the PCB 28/56 connector for the conflict monitor unit (CMU) with 28 independent contacts per side, dual-sided with 0.156 inch contact centers. Provide the PCB 28/56 connector contacts with solder eyelet terminations. Ensure all connections to the PCB 28/56 connector are soldered to the solder eyelet terminations.

Ensure that all cabinets have the CMU connector wired according to the 332 cabinet connector pin assignments (include all wires for auxiliary output file connection). Wire pins 13, 16, R, and U of the CMU connector to a separate 4 pin plug, P1, as shown below. Provide a second plug, P2, which will mate with P1 and is wired to the auxiliary output file as shown below. Provide an additional plug, P3, which will mate with P1 and is wired to the pedestrian yellow circuits as shown

R-5799**TS-18****Transylvania County**

below. When no auxiliary output file is installed in the cabinet, provide wires for the green and yellow inputs for channels 11, 12, 17, and 18, the red inputs for channels 17 and 18, and the wires for the P2 plug. Terminate the two-foot wires with ring type lugs, insulated, and bundled for optional use.

PIN	P1		P2		P3	
	FUNCTION	CONN TO	FUNCTION	CONN TO	FUNCTION	CONN TO
1	CH-9G	CMU-13	OLA-GRN	A123	2P-YEL	114
2	CH-9Y	CMU-16	OLA-YEL	A122	4P-YEL	105
3	CH-10G	CMU-R	OLB-GRN	A126	6P-YEL	120
4	CH-10Y	CMU-U	OLB-YEL	A125	8P-YEL	111

Do not provide the P20 terminal assembly (red monitor board) or red interface ribbon cable as specified in LA Specification No. 54-053-08.

Provide a P20 connector that mates with and is compatible with the red interface connector mounted on the front of the conflict monitor. Ensure that the P20 connector and the red interface connector on the conflict monitor are center polarized to ensure proper connection. Ensure that removal of the P20 connector will cause the conflict monitor to recognize a latching fault condition and place the cabinet into flashing operation.

Wire the P20 connector to the output file and auxiliary output file using 22 AWG stranded wires. Ensure the length of these wires is a minimum of 42 inches in length. Provide a durable braided sleeve around the wires to organize and protect the wires.

Wire the P20 connector to the traffic signal red displays to provide inputs to the conflict monitor as shown below. Ensure the pedestrian Don't Walk circuits are wired to channels 13 through 16 of the P20 connector. When no auxiliary output file is installed in the cabinet, provide wires for channels 9 through 12 reds. Provide a wire for special function 1. Terminate the unused wires with ring type lugs, insulated, and bundled for optional use.

P20 Connector					
PIN	FUNCTION	CONN TO	PIN	FUNCTION	CONN TO
1	Channel 15 Red	119	2	Channel 16 Red	110
3	Channel 14 Red	104	4	Chassis GND	01-9
5	Channel 13 Red	113	6	N/C	
7	Channel 12 Red	AUX 101	8	Spec Function 1	
9	Channel 10 Red	AUX 124	10	Channel 11 Red	AUX 114
11	Channel 9 Red	AUX 121	12	Channel 8 Red	107
13	Channel 7 Red	122	14	Channel 6 Red	134
15	Channel 5 Red	131	16	Channel 4 Red	101
17	Channel 3 Red	116	18	Channel 2 Red	128
19	Channel 1 Red	125	20	Red Enable	01-14

Ensure the controller unit outputs to the auxiliary output file are pre-wired to the C5 connector. When no auxiliary output file is installed in the cabinet, connect the C5 connector to a storage socket located on the Input Panel or on the rear of the PDA.

Do not wire pin 12 of the load switch sockets.

In addition to the requirements of LA Specification No. 54-053-08, ensure relay K1 on the Power Distribution Assembly (PDA) is a four pole relay and K2 on the PDA is a two pole relay.

Provide a two pole, ganged circuit breaker for the flash bus circuit. Ensure the flash bus circuit breaker is an inverse time circuit breaker rated for 10 amps at 120 VAC with a minimum of 10,000 RMS symmetrical amperes short circuit current rating. Do not provide the auxiliary switch feature on the flash bus circuit breaker. Ensure the ganged flash bus circuit breaker is certified by the circuit breaker manufacturer to provide gung tripping operation.

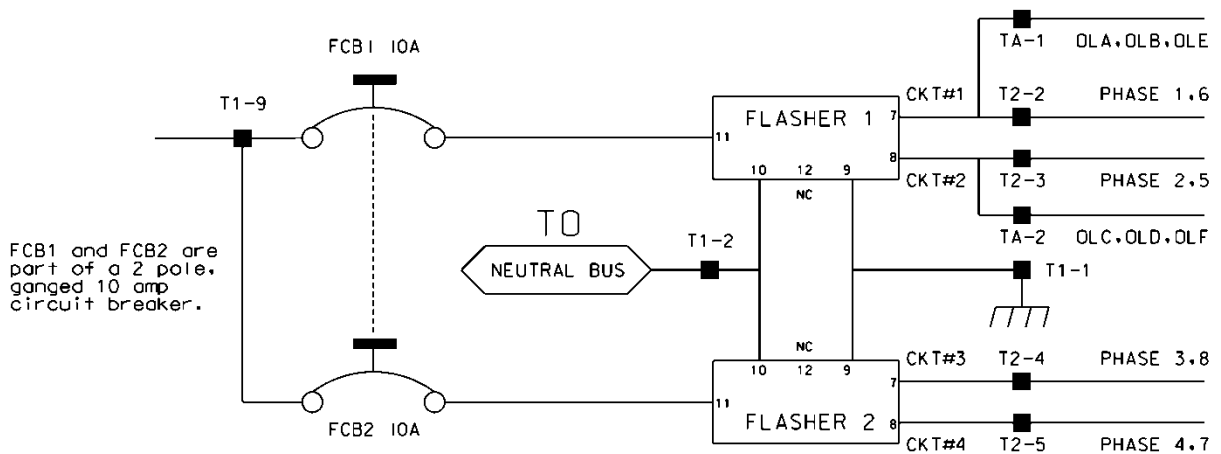

Ensure auxiliary output files are wired as follows:

R-5799

TS-20

Transylvania County

AUXILIARY OUTPUT FILE TERMINAL BLOCK TA ASSIGNMENTS	
POSITION	FUNCTION
1	Flasher Unit #1, Circuit 1/FTR1 (OLA, OLB)/FTR3 (OLE)
2	Flasher Unit #1, Circuit 2/FTR2 (OLC, OLD)/FTR3 (OLF)
3	Flash Transfer Relay Coils
4	AC -
5	Power Circuit 5
6	Power Circuit 5
7	Equipment Ground Bus
8	NC

Provide four spare load resistors mounted in each cabinet. Ensure each load resistor is rated as shown in the table below. Wire one side of each load resistor to AC-. Connect the other side of each resistor to a separate terminal on a four (4) position terminal block. Mount the load resistors and terminal block either inside the back of Output File No. 1 or on the upper area of the Service Panel.

ACCEPTABLE LOAD RESISTOR VALUES	
VALUE (ohms)	WATTAGE
1.5K – 1.9 K	25W (min)
2.0K – 3.0K	10W (min)

Provide Model 200 load switches, Model 204 flashers, Model 242 DC isolators, Model 252 AC isolators, and Model 206L power supply units that conform to CALTRANS' "Transportation Electrical Equipment Specifications" dated March 12, 2009 with Erratum 1.

C. Type 170 E Cabinet Physical Requirements:

Do not mold, cast, or scribe the name "City of Los Angeles" on the outside of the cabinet door as specified in LA Specification No. 54-053-08. Do not provide a Communications Terminal Panel as specified in LA Specification No. 54-053-08. Do not provide terminal block TBB on the Service Panel. Do not provide Cabinet Verification Test Program software or associated test jigs as specified in LA Specification No. 54-053-08.

Furnish unpainted, natural, aluminum cabinet shells. Ensure that all non-aluminum hardware on the cabinet is stainless steel or a Department approved non-corrosive alternate.

Ensure the lifting eyes, gasket channels, police panel, and all supports welded to the enclosure and doors are fabricated from 0.125 inch minimum thickness aluminum sheet and meet the same standards as the cabinet and doors.

R-5799**TS-21****Transylvania County**

Provide front and rear doors with latching handles that allow padlocking in the closed position. Furnish 0.75 inch minimum diameter stainless steel handles with a minimum 0.5 inch shank. Place the padlocking attachment at 4.0 inches from the handle shank center to clear the lock and key. Provide an additional 4.0 inches minimum gripping length.

Provide Corbin #2 locks on the front and rear doors. Provide one (1) Corbin #2 and one (1) police master key with each cabinet. Ensure main door locks allow removal of keys in the locked position only.

Provide a surge protection panel with 16 loop surge protection devices and designed to allow sufficient free space for wire connection/disconnection and surge protection device replacement. For model 332 cabinets, provide an additional 20 loop surge protection devices. Provide an additional two AC+ interconnect surge devices to protect one slot and eight DC surge protection devices to protect four slots. Provide no protection devices on slot I14.

For pole mounted cabinets, mount surge protection devices for the AC+ interconnect inputs, inductive loop detector inputs, and low voltage DC inputs on a swing down panel assembly fabricated from sturdy aluminum. Attach the swing down panel to the bottom rear cabinet rack assembly using thumb screws. Ensure the swing down panel allows for easy removal of the input file without removing the surge protection panel assembly or its parts. Have the surge protection devices mounted horizontally on the panel and soldered to the feed through terminals of four 14 position terminal blocks with #8 screws mounted on the other side. Ensure the top row of terminals is connected to the upper slots and the bottom row of terminals is connected to the bottom slots. Provide a 15 position copper equipment ground bus attached to the field terminal side (outside) of the swing down panel for termination of loop lead-in shield grounds. Ensure that a Number 4 AWG green wire connects the surge protection panel assembly ground bus to the main cabinet equipment ground.

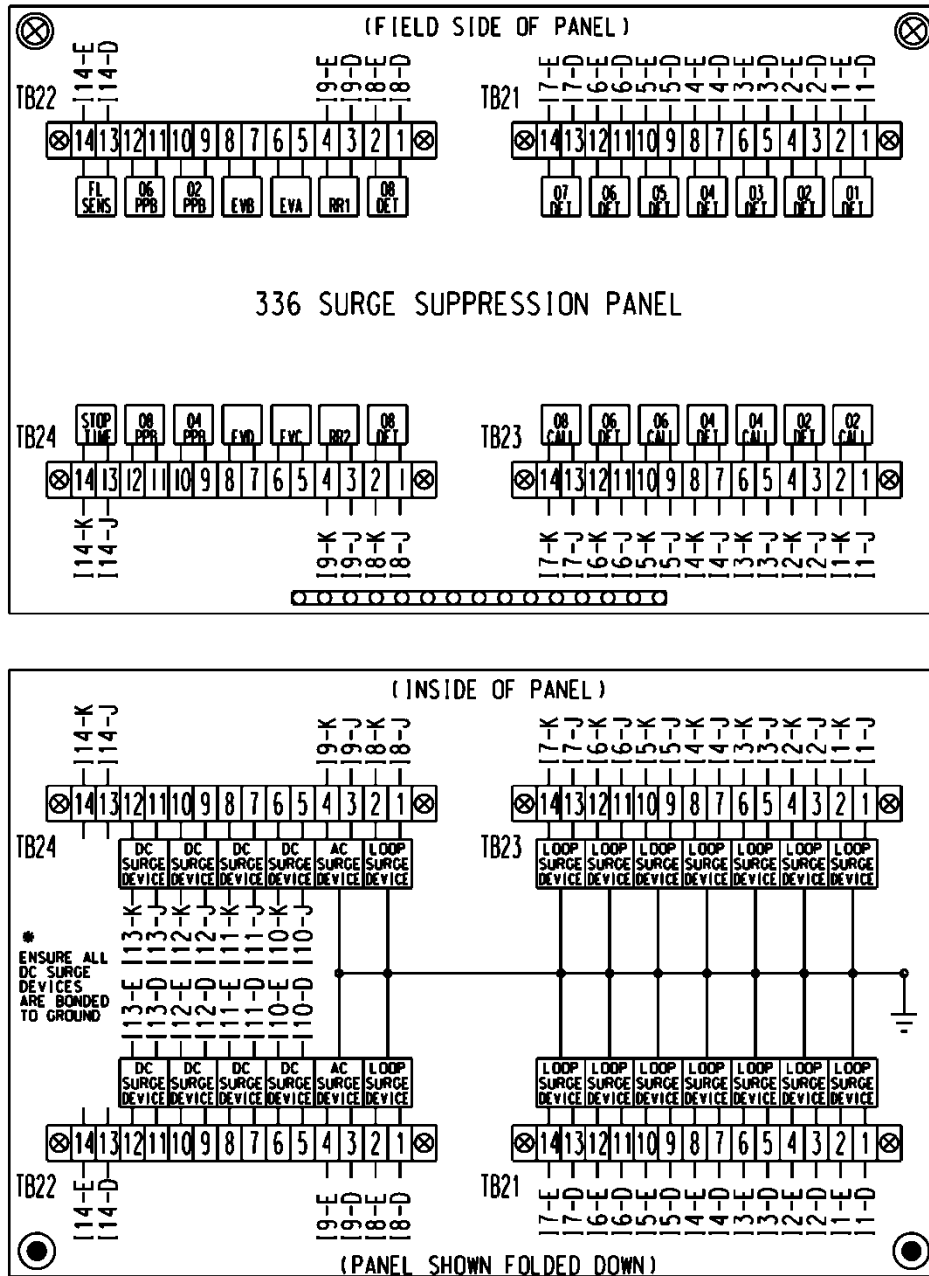

For base mounted cabinets, mount surge protection panels on the left side of the cabinet as viewed from the rear. Attach each panel to the cabinet rack assembly using bolts and make it easily removable. Mount the surge protection devices in vertical rows on each panel and connect the devices to one side of 12 position, double row terminal blocks with #8 screws. For each surge protection panel, terminate all grounds from the surge protection devices on a copper equipment ground bus attached to the surge protection panel. Wire the terminals to the rear of a standard input file using spade lugs for input file protection.

Provide permanent labels that indicate the slot and the pins connected to each terminal that may be viewed from the rear cabinet door. Label and orient terminals so that each pair of inputs is next to each other. Indicate on the labeling the input file (I or J), the slot number (1-14) and the terminal pins of the input slots (either D & E for upper or J & K for lower).

Provide a minimum 14 x 16 inch pull out, hinged top shelf located immediately below controller mounting section of the cabinet. Ensure the shelf is designed to fully expose the table surface outside the controller at a height approximately even with the bottom of the controller. Ensure the shelf has a storage bin interior which is a minimum of 1 inch deep and approximately the same dimensions as the shelf. Provide an access to the storage area by lifting the hinged top of the shelf. Fabricate the shelf and slide from aluminum or stainless steel and ensure the assembly can support the 2070L controller plus 15 pounds of additional weight. Ensure shelf has a locking mechanism to secure it in the fully extended position and does not inhibit the removal of the 2070L controller or removal of cards inside the controller when fully extended. Provide a locking mechanism that is easily released when the shelf is to be returned to its non-use position directly under the controller.

D. Model 2018 Enhanced Conflict Monitor:

Furnish Model 2018 Enhanced Conflict Monitors that provide monitoring of 18 channels. Ensure each channel consists of a green, yellow, and red field signal input. Ensure that the conflict monitor meets or exceeds CALTRANS' Transportation Electrical Equipment Specifications dated March 12, 2009, with Erratum 1 (hereafter referred to as CALTRANS' 2009 TEES) for a model 210 monitor unit and other requirements stated in this specification.

Ensure the conflict monitor is provided with an 18 channel conflict programming card. Pin EE and Pin T of the conflict programming card shall be connected together. Pin 16 of the conflict programming card shall be floating. Ensure that the absence of the conflict programming card will cause the conflict monitor to trigger (enter into fault mode), and remain in the triggered state until the programming card is properly inserted and the conflict monitor is reset.

Provide a conflict monitor that incorporates LED indicators into the front panel to dynamically display the status of the monitor under normal conditions and to provide a comprehensive review of field inputs with monitor status under fault conditions. Ensure that the monitor indicates the channels that were active during a conflict condition and the channels that experienced a failure for all other per channel fault conditions detected. Ensure that these indications and the status of each channel are retained until the Conflict Monitor is reset. Furnish LED indicators for the following:

- AC Power (Green LED indicator)
- VDC Failed (Red LED indicator)
- WDT Error (Red LED indicator)
- Conflict (Red LED indicator)
- Red Fail (Red LED indicator)
- Dual Indication (Red LED indicator)
- Yellow/Clearance Failure (Red LED indicator)
- PCA/PC Ajar (Red LED indicator)
- Monitor Fail/Diagnostic Failure (Red LED indicator)

- 54 Channel Status Indicators (1 Red, 1 Yellow, and 1 Green LED indicator for each of the 18 channels)

Provide a switch to set the Red Fail fault timing. Ensure that when the switch is in the ON position the Red Fail fault timing value is set to 1350 +/- 150 ms (2018 mode). Ensure that when the switch is in the OFF position the Red Fail fault timing value is set to 850 +/- 150 ms (210 mode).

Provide a switch to set the Watchdog fault timing. Ensure that when the switch is in the ON position the Watchdog fault timing value is set to 1.0 +/- 0.1 s (2018 mode). Ensure that when the switch is in the OFF position the Watchdog fault timing value is set to 1.5 +/- 0.1 s (210 mode).

Provide a jumper or switch to set the AC line brown-out levels. Ensure that when the jumper is present or the switch is in the ON position the AC line dropout voltage threshold is 98 +/- 2 Vrms, the AC line restore voltage threshold is 103 +/- 2 Vrms, and the AC line brown-out timing value is set to 400 +/- 50ms (2018 mode). Ensure that when the jumper is not present or the switch is in the OFF position the AC line dropout voltage threshold is 92 +/- 2 Vrms, the AC line restore voltage threshold is 98 +/- 2 Vrms, and the AC line brown-out timing value is set to 80 +/- 17 ms (210 mode).

Provide a jumper or switch that will enable and disable the Watchdog Latch function. Ensure that when the jumper is not present or the switch is in the OFF position the Watchdog Latch function is disabled. In this mode of operation, a Watchdog fault will be reset following a power loss, brownout, or power interruption. Ensure that when the jumper is present or the switch is in the ON position the Watchdog Latch function is enabled. In this mode of operation, a Watchdog fault will be retained until a Reset command is issued.

Provide a jumper that will reverse the active polarity for pin #EE (output relay common). Ensure that when the jumper is not present pin #EE (output relay common) will be considered 'Active' at a voltage greater than 70 Vrms and 'Not Active' at a voltage less than 50 Vrms (Caltrans mode). Ensure that when the jumper is present pin #EE (output relay common) will be considered 'Active' at a voltage less than 50 Vrms and 'Not Active' at a voltage greater than 70 Vrms (Failsafe mode).

In addition to the connectors required by CALTRANS' 2009 TEES, provide the conflict monitor with a red interface connector mounted on the front of the monitor. Ensure the connector is a 20 pin, right angle, center polarized, male connector with latching clip locks and polarizing keys. Ensure the right angle solder tails are designed for a 0.062" thick printed circuit board. Keying of the connector shall be between pins 3 and 5, and between 17 and 19. Ensure the connector has two rows of pins with the odd numbered pins on one row and the even pins on the other row. Ensure the connector pin row spacing is 0.10" and pitch is 0.10". Ensure the mating length of the connector pins is 0.24". Ensure the pins are finished with gold plating 30μ" thick.

R-5799

TS-25

Transylvania County

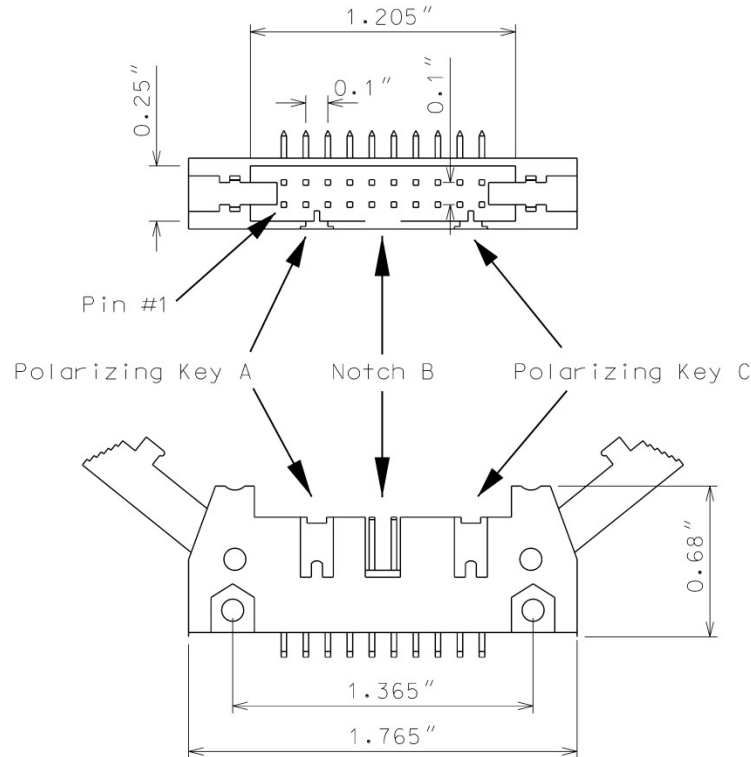

Ensure the red interface connector pins on the monitor have the following functions:

Pin #	Function	Pin #	Function
1	Channel 15 Red	2	Channel 16 Red
3	Channel 14 Red	4	Chassis Ground
5	Channel 13 Red	6	Special Function 2
7	Channel 12 Red	8	Special Function 1
9	Channel 10 Red	10	Channel 11 Red
11	Channel 9 Red	12	Channel 8 Red
13	Channel 7 Red	14	Channel 6 Red
15	Channel 5 Red	16	Channel 4 Red
17	Channel 3 Red	18	Channel 2 Red
19	Channel 1 Red	20	Red Enable

Ensure that removal of the P20 cable connector will cause the conflict monitor to recognize a latching fault condition and place the cabinet into flashing operation.

Provide Special Function 1 and Special Function 2 inputs to the unit which shall disable only Red Fail Monitoring when either input is sensed active. A Special Function input shall be sensed active when the input voltage exceeds 70 Vrms with a minimum duration of 550 ms. A Special Function input shall be sensed not active when the input voltage is less than 50 Vrms or the duration is less

than 250 ms. A Special Function input is undefined by these specifications and may or may not be sensed active when the input voltage is between 50 Vrms and 70 Vrms or the duration is between 250 ms and 550 ms.

Ensure the conflict monitor recognizes field signal inputs for each channel that meet the following requirements:

- consider a Red input greater than 70 Vrms and with a duration of at least 500 ms as an “on” condition;
- consider a Red input less than 50 Vrms or with a duration of less than 200 ms as an “off” condition (no valid signal);
- consider a Red input between 50 Vrms and 70 Vrms or with a duration between 200 ms and 500 ms to be undefined by these specifications;
- consider a Green or Yellow input greater than 25 Vrms and with a duration of at least 500 ms as an “on” condition;
- consider a Green or Yellow input less than 15 Vrms or with a duration of less than 200 ms as an “off” condition; and
- consider a Green or Yellow input between 15 Vrms and 25 Vrms or with a duration between 200 ms and 500 ms to be undefined by these specifications.

Provide a conflict monitor that recognizes the faults specified by CALTRANS’ 2009 TEES and the following additional faults. Ensure the conflict monitor will trigger upon detection of a fault and will remain in the triggered (in fault mode) state until the unit is reset at the front panel or through the external remote reset input for the following failures:

1. **Red Monitoring or Absence of Any Indication (Red Failure):** A condition in which no “on” voltage signal is detected on any of the green, yellow, or red inputs to a given monitor channel. If a signal is not detected on at least one input (R, Y, or G) of a conflict monitor channel for a period greater than 1000 ms when used with a 170 controller and 1500 ms when used with a 2070 controller, ensure monitor will trigger and put the intersection into flash. If the absence of any indication condition lasts less than 700 ms when used with a 170 controller and 1200 ms when used with a 2070 controller, ensure conflict monitor will not trigger. Red fail monitoring shall be enabled on a per channel basis by the use of switches located on the conflict monitor. Have red monitoring occur when all of the following input conditions are in effect:
 - a) Red Enable input to monitor is active (Red Enable voltages are “on” at greater than 70 Vrms, off at less than 50 Vrms, undefined between 50 and 70 Vrms), and
 - b) Neither Special Function 1 nor Special Function 2 inputs are active.
 - c) Pin #EE (output relay common) is not active
2. **Short/Missing Yellow Indication Fault (Clearance Error):** Yellow indication following a green is missing or shorter than 2.7 seconds (with ± 0.1 -second accuracy). If a channel fails to detect an “on” signal at the Yellow input for a minimum of 2.7 seconds (± 0.1 second) following the detection of an “on” signal at a Green input for that channel, ensure that the monitor triggers and generates a clearance/short yellow error fault indication. Short/missing

yellow (clearance) monitoring shall be enabled on a per channel basis by the use of switches located on the conflict monitor. This fault shall not occur when the channel is programmed for Yellow Inhibit, when the Red Enable signal is inactive or pin #EE (output relay common) is active.

3. **Dual Indications on the Same Channel:** In this condition, more than one indication (R,Y,G) is detected as “on” at the same time on the same channel. If dual indications are detected for a period greater than 500 ms, ensure that the conflict monitor triggers and displays the proper failure indication (Dual Ind fault). If this condition is detected for less than 200 ms, ensure that the monitor does not trigger. G-Y-R dual indication monitoring shall be enabled on a per channel basis by the use of switches located on the conflict monitor. G-Y dual indication monitoring shall be enabled for all channels by use of a switch located on the conflict monitor. This fault shall not occur when the Red Enable signal is inactive or pin #EE (output relay common) is active.
4. **Configuration Settings Change:** The configuration settings are comprised of (as a minimum) the permissive diode matrix, dual indication switches, yellow disable jumpers, any option switches, any option jumpers, and the Watchdog Enable switch. Ensure the conflict monitor compares the current configuration settings with the previous stored configuration settings on power-up, on reset, and periodically during operation. If any of the configuration settings are changed, ensure that the conflict monitor triggers and causes the program card indicator to flash. Ensure that configuration change faults are only reset by depressing and holding the front panel reset button for a minimum of three seconds. Ensure the external remote reset input does not reset configuration change faults.

Ensure the conflict monitor will trigger and the AC Power indicator will flash at a rate of 2 Hz \pm 20% with a 50% duty cycle when the AC Line voltage falls below the “drop-out” level. Ensure the conflict monitor will resume normal operation when the AC Line voltage returns above the “restore” level. Ensure the AC Power indicator will remain illuminated when the AC voltage returns above the “restore” level. Should an AC Line power interruption occur while the monitor is in the fault mode, then upon restoration of AC Line power, the monitor will remain in the fault mode and the correct fault and channel indicators will be displayed.

Provide a flash interval of at least 6 seconds and at most 10 seconds in duration following a power-up, an AC Line interruption, or a brownout restore. Ensure the conflict monitor will suspend all fault monitoring functions, close the Output relay contacts, and flash the AC indicator at a rate of 4 Hz \pm 20% with a 50% duty cycle during this interval. Ensure the termination of the flash interval after at least 6 seconds if the Watchdog input has made 5 transitions between the True and False state and the AC Line voltage is greater than the “restore” level. If the watchdog input has not made 5 transitions between the True and False state within 10 \pm 0.5 seconds, the monitor shall enter a WDT error fault condition.

Ensure the conflict monitor will monitor an intersection with a minimum of four approaches using the four-section Flashing Yellow Arrow (FYA) vehicle traffic signal as outlined by the NCHRP 3-54 research project for protected-permissive left turn signal displays. Ensure the conflict monitor will operate in the FYA mode and FYAc (Compact) mode as specified below to monitor each channel pair for the following fault conditions: Conflict, Flash Rate Detection, Red Fail, Dual Indication, and

R-5799**TS-28****Transylvania County**

Clearance. Provide a switch to select between the FYA mode and FYAc mode. Provide a switch to select each FYA phase movement for monitoring.

FYA mode

FYA Signal Head	Phase 1	Phase 3	Phase 5	Phase 7
Red Arrow	Channel 9 Red	Channel 10 Red	Channel 11 Red	Channel 12 Red
Yellow Arrow	Channel 9 Yellow	Channel 10 Yellow	Channel 11 Yellow	Channel 12 Yellow
Flashing Yellow Arrow	Channel 9 Green	Channel 10 Green	Channel 11 Green	Channel 12 Green
Green Arrow	Channel 1 Green	Channel 3 Green	Channel 5 Green	Channel 7 Green

FYAc mode

FYA Signal Head	Phase 1	Phase 3	Phase 5	Phase 7
Red Arrow	Channel 1 Red	Channel 3 Red	Channel 5 Red	Channel 7 Red
Yellow Arrow	Channel 1 Yellow	Channel 3 Yellow	Channel 5 Yellow	Channel 7 Yellow
Flashing Yellow Arrow	Channel 1 Green	Channel 3 Green	Channel 5 Green	Channel 7 Green
Green Arrow	Channel 9 Green	Channel 9 Yellow	Channel 10 Green	Channel 10 Yellow

If a FYA channel pair is enabled for FYA operation, the conflict monitor will monitor the FYA logical channel pair for the additional following conditions:

1. **Conflict:** Channel conflicts are detected based on the permissive programming jumpers on the program card. This operation remains unchanged from normal operation except for the solid Yellow arrow (FYA clearance) signal.
2. **Yellow Change Interval Conflict:** During the Yellow change interval of the Permissive Turn channel (flashing Yellow arrow) the conflict monitor shall verify that no conflicting channels to the solid Yellow arrow channel (clearance) are active. These conflicting channels shall be determined by the program card compatibility programming of the Permissive Turn channel (flashing Yellow arrow). During the Yellow change interval of the Protected Turn channel (solid Green arrow) the conflict monitor shall verify that no conflicting channels to the solid Yellow arrow channel (clearance) are active as determined by the program card compatibility programming of the Protected Turn channel (solid Green arrow).

3. **Flash Rate Detection:** The conflict monitor unit shall monitor for the absence of a valid flash rate for the Permissive turn channel (flashing Yellow arrow). If the Permissive turn channel (flashing Yellow arrow) is active for a period greater than 1600 milliseconds, ensure the conflict monitor triggers and puts the intersection into flash. If the Permissive turn channel (flashing Yellow arrow) is active for a period less than 1400 milliseconds, ensure the conflict monitor does not trigger. Ensure the conflict monitor will remain in the triggered (in fault mode) state until the unit is reset at the front panel or through the external remote reset input. Provide a jumper or switch that will enable and disable the Flash Rate Detection function. Ensure that when the jumper is not present or the switch is in the OFF position the Flash Rate Detection function is enabled. Ensure that when the jumper is present or the switch is in the ON position the Flash Rate Detection function is disabled.
4. **Red Monitoring or Absence of Any Indication (Red Failure):** The conflict monitor unit shall detect a red failure if there is an absence of voltage on all four of the inputs of a FYA channel pair (RA, YA, FYA, GA).
5. **Dual Indications on the Same Channel:** The conflict monitor unit shall detect a dual indication if two or more inputs of a FYA channel pair (RA, YA, FYA, GA) are “on” at the same time.
6. **Short/Missing Yellow Indication Fault (Clearance Error):** The conflict monitor unit shall monitor the solid Yellow arrow for a clearance fault when terminating both the Protected Turn channel (solid Green arrow) interval and the Permissive Turn channel (flashing Yellow arrow) interval.

Ensure that the conflict monitor will log at least nine of the most recent events detected by the monitor in non-volatile EEPROM memory (or equivalent). For each event, record at a minimum the time, date, type of event, status of each field signal indication with RMS voltage, and specific channels involved with the event. Ensure the conflict monitor will log the following events: monitor reset, configuration, previous fault, and AC line. Furnish the signal sequence log that shows all channel states (Greens, Yellows, and Reds) and the Red Enable State for a minimum of 2 seconds prior to the current fault trigger point. Ensure the display resolution of the inputs for the signal sequence log is not greater than 50 ms.

For conflict monitors used within an Ethernet communications system, provide a conflict monitor with an Ethernet 10/100 Mbps, RJ-45 port for data communication access to the monitor by a local notebook computer and remotely via a workstation or notebook computer device connected to the signal system local area network. The Ethernet port shall be electrically isolated from the conflict monitor’s electronics and shall provide a minimum of 1500 Vrms isolation. Integrate monitor with Ethernet network in cabinet. Provide software to retrieve the time and date from a network server in order to synchronize the on-board times between the conflict monitor and the controller. Furnish and install the following Windows based, graphic user interface software on workstations and notebook computers where the signal system client software is installed: 1) software to view and retrieve all event log information, 2) software that will search and display a list of conflict monitor IP addresses and IDs on the network, and 3) software to change the conflict monitor’s network parameters such as IP address and subnet mask.

For non-Ethernet connected monitors, provide a RS-232C/D compliant port (DB-9 female connector) on the front panel of the conflict monitor in order to provide communications from the conflict monitor to the 170/2070 controller or to a Department-furnished laptop computer. Electrically isolate the port interface electronics from all monitor electronics, excluding Chassis Ground. Ensure that the controller can receive all event log information through a controller

R-5799**TS-30****Transylvania County**

Asynchronous Communications Interface Adapter (Type 170E) or Async Serial Comm Module (2070). Furnish and connect a serial cable from the conflict monitor's DB-9 connector to Comm Port 1 of the 2070 controller. Ensure conflict monitor communicates with the controller. Provide a Windows based graphic user interface software to communicate directly through the same monitor RS-232C/D compliant port to retrieve and view all event log information to a Department-furnished laptop computer. The RS-232C/D compliant port on the monitor shall allow the monitor to function as a DCE device with pin connections as follows:

Conflict Monitor RS-232C/D (DB-9 Female) Pinout		
Pin Number	Function	I/O
1	DCD	O
2	TX Data	O
3	RX Data	I
4	DTR	I
5	Ground	-
6	DSR	O
7	CTS	I
8	RTS	O
9	NC	-

R-5799

TS-31

Transylvania County

MONITOR BOARD EDGE CONNECTOR

Pin #	Function (Back Side)	Pin #	Function (Component Side)
1	Channel 2 Green	A	Channel 2 Yellow
2	Channel 13 Green	B	Channel 6 Green
3	Channel 6 Yellow	C	Channel 15 Green
4	Channel 4 Green	D	Channel 4 Yellow
5	Channel 14 Green	E	Channel 8 Green
6	Channel 8 Yellow	F	Channel 16 Green
7	Channel 5 Green	H	Channel 5 Yellow
8	Channel 13 Yellow	J	Channel 1 Green
9	Channel 1 Yellow	K	Channel 15 Yellow
10	Channel 7 Green	L	Channel 7 Yellow
11	Channel 14 Yellow	M	Channel 3 Green
12	Channel 3 Yellow	N	Channel 16 Yellow
13	Channel 9 Green	P	Channel 17 Yellow
14	Channel 17 Green	R	Channel 10 Green
15	Channel 11 Yellow	S	Channel 11 Green
16	Channel 9 Yellow	T	Channel 18 Yellow
17	Channel 18 Green	U	Channel 10 Yellow
--		--	
18	Channel 12 Yellow	V	Channel 12 Green
19	Channel 17 Red	W	Channel 18 Red
20	Chassis Ground	X	Not Assigned
21	AC-	Y	DC Common
22	Watchdog Timer	Z	External Test Reset
23	+24VDC	AA	+24VDC
24	Tied to Pin 25	BB	Stop Time (Output)
25	Tied to Pin 24	CC	Not Assigned
26	Not Assigned	DD	Not Assigned
27	Relay Output, Side #3, N.O.	EE	Relay Output, Side #2, Common
28	Relay Output, Side #1, N.C.	FF	AC+

-- Slotted for keying between Pins 17/U and 18/V

R-5799

TS-32

Transylvania County

CONFLICT PROGRAM CARD PIN ASSIGNMENTS

Pin #	Function (Back Side)	Pin #	Function (Component Side)
1	Channel 2 Green	A	Channel 1 Green
2	Channel 3 Green	B	Channel 2 Green
3	Channel 4 Green	C	Channel 3 Green
4	Channel 5 Green	D	Channel 4 Green
5	Channel 6 Green	E	Channel 5 Green
6	Channel 7 Green	F	Channel 6 Green
7	Channel 8 Green	H	Channel 7 Green
8	Channel 9 Green	J	Channel 8 Green
9	Channel 10 Green	K	Channel 9 Green
10	Channel 11 Green	L	Channel 10 Green
11	Channel 12 Green	M	Channel 11 Green
12	Channel 13 Green	N	Channel 12 Green
13	Channel 14 Green	P	Channel 13 Green
14	Channel 15 Green	R	Channel 14 Green
15	Channel 16 Green	S	Channel 15 Green
16	N/C	T	PC AJAR
17	Channel 1 Yellow	U	Channel 9 Yellow
18	Channel 2 Yellow	V	Channel 10 Yellow
19	Channel 3 Yellow	W	Channel 11 Yellow
20	Channel 4 Yellow	X	Channel 12 Yellow
21	Channel 5 Yellow	Y	Channel 13 Yellow
22	Channel 6 Yellow	Z	Channel 14 Yellow
23	Channel 7 Yellow	AA	Channel 15 Yellow
24	Channel 8 Yellow	BB	Channel 16 Yellow
--		--	
25	Channel 17 Green	CC	Channel 17 Yellow
26	Channel 18 Green	DD	Channel 18 Yellow
27	Channel 16 Green	EE	PC AJAR (Program Card)
28	Yellow Inhibit Common	FF	Channel 17 Green

-- Slotted for keying between Pins 24/BB and 25/CC

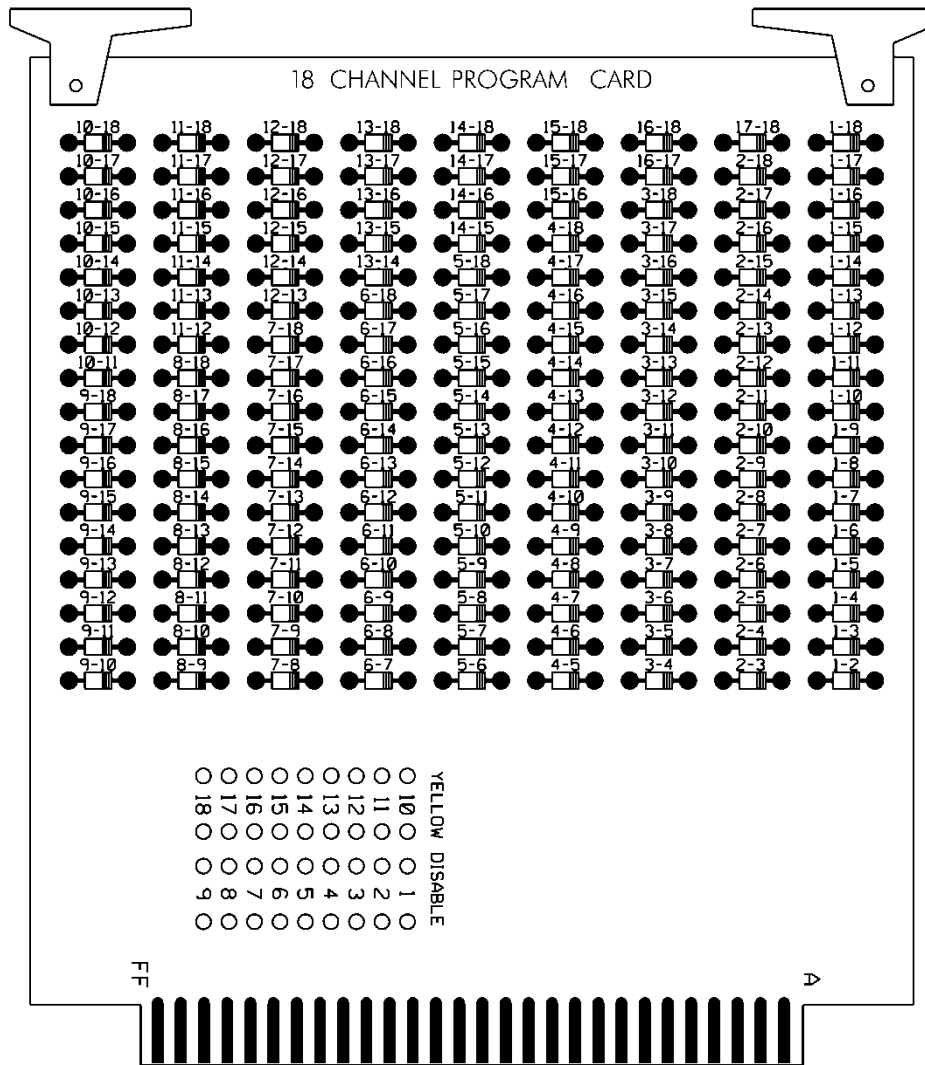

E. Preemption and Sign Control Box

Provide preemption and sign control box to operate in a Model 332 and Model 336S cabinet. Provide hardware to mount the box to the cage of the cabinet to ensure the front side is facing the opposite side of the cabinet. Furnish the material of the box from a durable finished metallic or thermoplastic case. Ensure the size of the box is not greater than 7(l) x 5(w) x 5(d) inches. Ensure that no modification is necessary to mount the box on the cabinet cage.

Provide the following components in the preemption and sign control box: relays, fuses, terminal blocks, MOVs, resistor, RC network, lamp, and push button switch.

Provide UL Listed or Recognized relay K1 as a DPDT enclosed relay (120 VAC, 60 Hz coil) with an 8-pin octal-style plug and associated octal base. Provide contact material made of AgCdO with a 10 amp, 240 VAC rating. Ensure the relay has a specified pickup voltage of 102 VAC.

Provide relay SSR1 as a Triac SPST normally open solid state relay that is rated for 120 VAC input and zero-crossing (resistive load) 25 amp @ 120 VAC output. Ensure the relay turns on at 90 Vrms within 10 ms and turns off at 10 Vrms within 40 ms. Ensure the relay has physical

R-5799**TS-34****Transylvania County**

characteristics as shown in the wiring detail in Figure 1. Provide 4 terminal screws with saddle clamps.

Provide fuses F1 and F2 as a UL Listed ¼" x 1-1/4" glass tube rated at 250 volts with a 10kA interrupting rating. Ensure F1 non-delay (fast-acting) and F2 slow-blow (time-delay) fuses have a maximum opening times of 60 minutes and 120 seconds for currents of 135 and 200 percent of the ampere rating, respectively. Ensure F2 slow-blow (time-delay) fuses have a minimum opening times of 12 seconds at 200 percent of the ampere rating. Provide fuse holders that are UL Recognized panel-mounted holders rated 250V, 15 ampere minimum with bayonet-type knobs which accept ¼" x 1-1/4" glass tube fuses.

Provide terminal blocks that are rated for 300V and are made of electrical grade thermoplastic or thermosetting plastic. Ensure each terminal block is of closed back design and has recessed-screw terminals with molded barriers between terminals. Ensure each terminal block is labeled with a block designation. Ensure each terminal is labeled with the function and a number.

Provide 3/4-inch diameter radial lead UL-recognized metal oxide varistors (MOVs) that have electrical performance as outlined below.

PROPERTIES OF MOV SURGE PROTECTOR	
Maximum Continuous Applied Voltage at 185° F	150 VAC (RMS) 200 VDC
Maximum Peak 8x20µs Current at 185° F	6500 A
Maximum Energy Rating at 185° F	80 J
Voltage Range 1 mA DC Test at 77° F	212-268 V
Max. Clamping Voltage 8x20µs, 100A at 77° F	395 V
Typical Capacitance (1 MHz) at 77° F	1600 pF

Provide resistor R1 as a 2K ohm, 12 watt, wirewound resistor with tinned terminals and attaching leads. Ensure the resistor is spaced apart from surrounding wires.

Provide a LED or incandescent lamp that has a voltage rating of 120 VAC with a minimum life rating at 50,000 hours.

Wire the preemption and sign control box as shown in Figure 1.

RAILROAD PREEMPTION WIRING DETAIL

(wire as shown below)

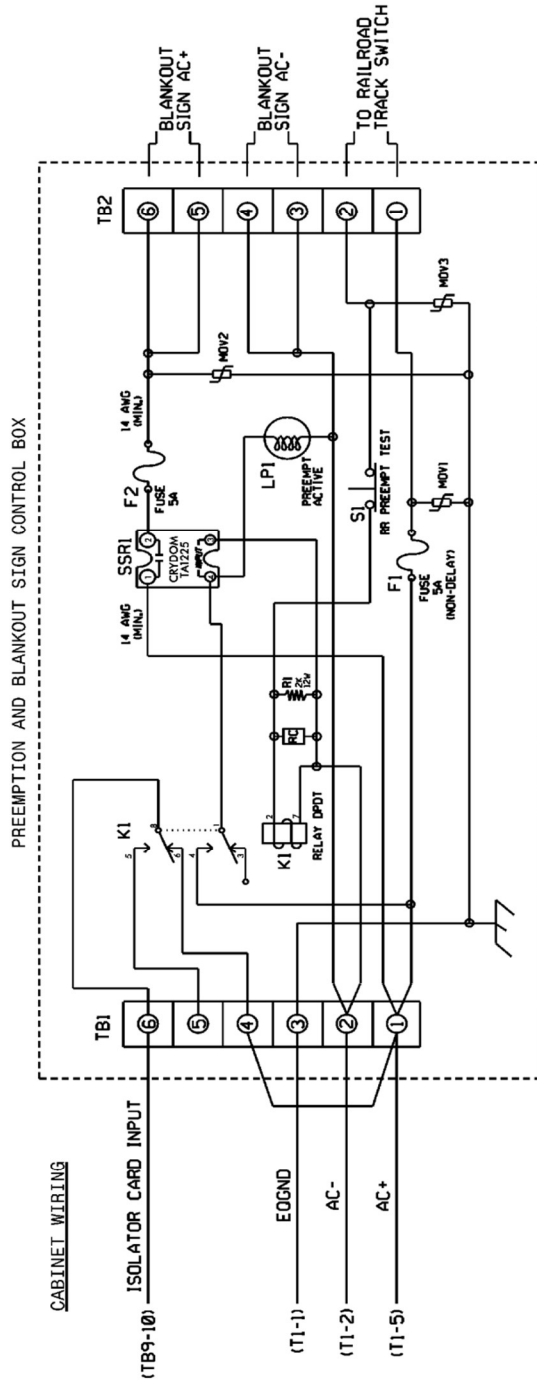

NOTES

1. RELAY K1 IS SHOWN IN THE ENERGIZED (PREEMPT NOT ACTIVE) NORMAL OPERATION STATE.
2. AC ISOLATOR CARD SHALL ACTIVATE PREEMPTION UPON REMOVAL OF AC+ FROM INPUT (AS SHOWN ABOVE). THIS IS ACCOMPLISHED BY SETTING TYPE 252 AC ISOLATOR CARD TO INVERTED OPERATION.

FRONT VIEW

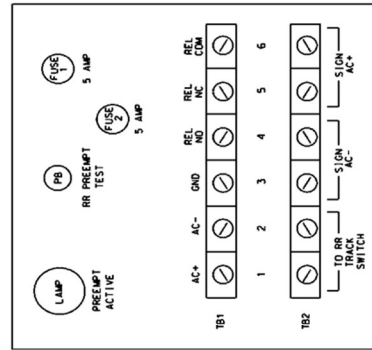

Figure 1

R-5799

TS-36

Transylvania County

3.4. MATERIALS – TYPE 170 DETECTOR SENSOR UNITS

Furnish detector sensor units that comply with Chapter 5 Section 1, “General Requirements,” and Chapter 5 Section 2, “Model 222 & 224 Loop Detector Sensor Unit Requirements,” of the CALTRANS “Transportation Electrical Equipment Specifications” dated March 12, 2009 with Erratum 1.

4. CONTROLLERS WITHOUT CABINETS**4.1. MATERIALS – TYPE 2070LX CONTROLLERS**

Furnish model 2070LX controller units that conform to CALTRANS *Transportation Electrical Equipment Specifications* (TEES) (dated March 12, 2009, plus Errata 1 dated January 21, 2010 and Errata 2 dated December 5, 2014) except as required herein.

The Department will provide software at the beginning of the burning-in period. Contractor shall give 5 working days notice before needing software. Program software provided by the Department.

Provide model 2070LX controllers with Linux kernel 2.6.18 or higher and device drivers, composed of the unit chassis and at a minimum the following modules and assemblies:

- MODEL 2070-1C, CPU Module, Single Board, with 8Mb Datakey (blue in color)
- MODEL 2070-2E+, Field I/O Module (FI/O)
 - Note: Configure the Field I/O Module to disable both the External WDT Shunt/Toggle Switch and SP3 (SP3 active indicator is “off”)
- MODEL 2070-3B, Front Panel Module (FP), Display B (8x40)
- MODEL 2070-4A, Power Supply Module, 10 AMP

Provide a Board Support Package (BSP) to the state and to any specified applications software manufacturer when requested by the state to facilitate the porting of application software.

4.2. MEASUREMENT AND PAYMENT

Actual number of 2070LX controllers furnished, installed, and accepted.

No measurement will be made of cables or hardware, as these will be considered incidental to furnishing and installing the 2070LX controllers.

Payment will be made under:

Type 2070LX Controller.....Each

5. PUSH BUTTON INTEGRATED ACCESSIBLE PEDESTRIAN SIGNAL (APS)**5.1. DESCRIPTION**

Furnish and install push button integrated accessible pedestrian signals that include pedestrian pushbutton, pushbutton locator tone, raised tactile arrow, audio and vibro-tactile walk indications, automatic volume adjustment, pedestrian information sign, and all necessary hardware. Furnish the R10-3e with appropriate arrow direction for the pedestrian information sign.

5.2. MATERIALS

Furnish material, equipment, and hardware under this section that is pre-approved on the ITS and Signals QPL.

Provide the accessible pedestrian signals with a 2-inch diameter pedestrian push button that contains a tactile arrow whose direction can be easily adjusted in the field. Ensure each push button

actuates a sturdy, momentary, normally-open switch with a minimum rating of 20 million actuations. Include on the button, a raised tactile arrow having a high visual contrast with the remainder of the button face. Ensure the housing is weather-tight and fabricated from aluminum. Ensure the housing is suitable for mounting on wood and metal poles. Paint surfaces of the pedestrian push button housing in highway yellow, unless otherwise specified, with an electrostatically-applied, fused-polyester paint method. Ensure the thickness of the paint is a minimum of 2.5 mils. Provide the pedestrian information sign that is integral to the housing.

Ensure the accessible pedestrian signals can provide tones, sounds, and speech messages that are synchronized at an intersection. Provide a means for adjusting the base sound level for the tones, sounds, and speech messages. Ensure the tones, sounds, and speech messages will adjust automatically to the ambient noise level up to a maximum of 100 dBA. Provide the custom speech messages in both English and Spanish languages. Ensure you can program the accessible pedestrian signal by a means not readily accessible by unauthorized persons.

Ensure each push button provides a standard locator tone that is deactivated when the traffic signal is operating in the flash mode. Provide a user-programmable audible beaconing feature that is initiated by an extended push button press of one second or more. Ensure the audible beaconing feature increases the volume of the push button locator tone during the pedestrian change interval of the called pedestrian phase and operates in one of the following ways:

- A. The louder audible walk indication and louder locator tone comes from the far end of the crosswalk, as pedestrians cross the street,
- B. The louder locator tone comes from both ends of the crosswalk, or
- C. The louder locator tone comes from an additional speaker that is aimed at the center of the crosswalk and that is mounted on a pedestrian signal head.

Provide confirmation of the push button activation by an LED pilot light. Ensure the pilot light remains illuminated until the pedestrian's green or WALKING PERSON (symbolizing WALK) signal indication is displayed. Ensure each press of the pushbutton initiates a "wait" speech message during all intervals except the Walk interval.

Ensure you can select a percussive tone and custom speech message to sound during the "Walk" interval. Provide a push button that vibrates during the "Walk" interval. Ensure the "Walk" indications have the same duration as the illuminated pedestrian signals except when the signal is programmed to rest in the walk interval. When the pedestrian signal is programmed to rest in walk, ensure the "Walk" indication is limited to the first 7 seconds of the walk interval. The "Walk" indication shall be recalled by a button press during the walk interval provided that the crossing time remaining is greater than the pedestrian change interval. Ensure the "Walk" indications are deactivated when the traffic control signal is operating in a flashing mode. When audible "Walk" indications are selected as a percussive tone, ensure the tone repeats at 8 to 10 ticks per second and consists of multiple frequencies with a dominant component at 880 Hz.

Ensure the accessible pedestrian signals are weatherproof and suitable for operation in wet locations. Ensure proper operation over a temperature range of -30°F (-34°C) to 165°F (+74°C). Ensure all circuit boards have a moisture resistant coating. Ensure the equipment interfaces and operates properly in a Type-170E cabinet.

If the accessible pedestrian signal is required by the Engineer to have a touchless feature, then ensure a pedestrian call is placed when a hand is waved from 1 to 6 inches across the front of the Push Button.

5.3. CONSTRUCTION METHODS

Comply with the requirements of Section 1705 of the *Standard Specifications*. Install in accordance with the manufacturer’s recommendations.

Mount push button integrated accessible pedestrian signals in a tamperproof manner on wood and metal poles, signal pedestals, or pushbutton posts as indicated in the signal plans.

Install each pushbutton so that the tactile arrow is pointed in the direction of travel and is aligned parallel to the direction of travel on the associated crosswalk.

Ensure pushbuttons are separated by a distance of at least 10 feet such that they clearly indicate which crosswalk has the WALK indication. Where there are constraints on a particular corner that make it impractical to provide the 10 feet of separation between the two pushbuttons, the pushbuttons may be placed closer together or on the same pole, with approval by the Engineer. If two pushbuttons are placed on the same pole or with less than 10 feet separation, provide a speech walk message for the WALK indication and a speech pushbutton information message.

Adjust the intensity of the pushbutton locator tones so they are audible 6 feet to 12 feet from the pushbutton, or to the building line, whichever is less. Ensure the pushbutton locator tones are no more than 5 dBA louder than ambient sound. Configure audible “Walk” indication to be audible at the nearest end of the associated crosswalk.

If speech messages are used, have each recorded custom speech message approved by the Engineer in advance.

5.4. MEASUREMENT AND PAYMENT

Actual number of push button integrated accessible pedestrian signal detector stations furnished, installed, and accepted.

Actual number of central control units for APS detector stations furnished, installed, and accepted.

No measurement will be made of cables or hardware, as these will be considered incidental to furnishing and installing push button integrated accessible pedestrian signals.

Payment will be made under:

APS Detector Stations.....	Each
Central Control Units For APS Detector Stations	Each

6. MICROWAVE VEHICLE DETECTION SYSTEM - MULTIPLE DETECTION ZONES

6.1. DESCRIPTION

Design, furnish and install a microwave vehicle detection system with the manufacturer recommended cables and hardware in accordance to the plans and specifications. Ensure the detection system provides multiple detection zones.

6.2. MATERIALS

Provide design drawings showing design details and microwave sensor locations for review and acceptance before installation. Provide mounting height and location requirements for microwave sensor units on the design based on a site survey. Design microwave vehicle detection system with all necessary hardware. Indicate all necessary poles, spans, mast arms, luminaire arms, cables, microwave sensor mounting assemblies and hardware to achieve the required detection zones where Department owned poles are not adequate to locate the microwave sensor units. Do not design for the installation of poles in medians.

Obtain the Engineer's approval before furnishing microwave vehicle detection system. The contractor is responsible for the final design of microwave vehicle detection system. Review and acceptance of the designs by the Department does not relieve the contractor from the responsibility to provide fully functional systems and to ensure that the required detection zones can be provided. With the exception of contractor-furnished poles, mast arms, and luminaire arms, furnish material, equipment, and hardware under this section that is pre-approved on the ITS and Signals QPL. Submit and obtain Engineer's approval of shop drawings for any poles, mast arms, and luminaire arms provided by the contractor prior to ordering from manufacturer.

Provide a detector for either side-fire or forward-fire configuration. Ensure the detector will detect vehicles in sunny, cloudy, rainy, snowy, and foggy weather conditions. Ensure the detector can operate from the voltage supplied by a NEMA TS-1/TS-2 or Type 332 or 336 traffic signal cabinet. Ensure the detector can provide detection calls to the traffic signal controller within a NEMA TS-1/TS-2 or Type 332 or 336 cabinet. Ensure the detection system provides a constant call in the event of a component failure or loss of power. Ensure the detector has an operating temperature range of -30 to 165 degrees F and operates within the frequency range of 10 to 25 GHz. Ensure the detector is provided with a water-tight housing offering NEMA 4X protection and operates properly in up to 95% relative humidity, non-condensing.

Provide each detector unit to allow the placement of at least 8 detection zones with a minimum of 8 detection channel outputs. When the microwave vehicle detection system requires an integrated card rack interface(s), provide only enough interface cards to implement the vehicle detection shown on the signal plans. Provide a means acceptable to the Engineer to configure traffic lanes and detection zones. Provide each channel output with a programmable means to delay the output call upon activation of a detection zone that is adjustable in one second increments (maximum) over the range of 0 to 25 seconds. Provide each channel output with a programmable means to extend the output call that is adjustable in one second increments (maximum) over the range of 0 to 25 seconds. Ensure both delay and extend timing can be set for the same channel output.

For advance detection system, ensure the detector senses vehicles in motion at a range of 50 to 400 feet from the detector unit for forward-fire configuration and a range of 50 to 200 feet from the detector unit for side-fire configuration with an accuracy of 95% for both configurations. Ensure the advance detection system provides each channel output call of at least 100 ms in duration.

For stop bar presence detection system, ensure the detector outputs a constant call while a vehicle is in the detection zone and removes the call after all vehicles exit the detection zone. Ensure the presence detector unit can cover a detection zone as shown on the plans and has an effective range of 10 to 120 feet from the detector unit.

For units without an integrated card rack interface, provide Form C output relay contacts rated a minimum of 3A, 24VDC.

If a laptop is used to adjust detector settings, ensure that software is licensed for use by the Department and by any other agency responsible for maintaining or operating the microwave detection system. Provide the Department with a license to duplicate and distribute the software as necessary for design and maintenance support.

After initial detector configuration and installation, ensure routine adjustments or calibration are not needed to maintain acceptable performance.

6.3. CONSTRUCTION METHODS

Install the microwave vehicle detection system in accordance with the manufacturer's recommendations.

Monitor and maintain each detector unit during construction to ensure microwave vehicle detection system is functioning properly and aimed for the detection zone shown in the plans. Refer to Subarticle 1700-3 (D) Maintenance and Repair of Materials of the *Standard Specifications* for failure to maintain the microwave detection system.

6.4. MEASUREMENT AND PAYMENT

Actual number of microwave vehicle detection systems – multiple zones furnished, installed, and accepted.

No measurement will be made of cables or hardware, as these will be considered incidental to furnishing and installing microwave vehicle detection systems.

Payment will be made under:

Microwave Vehicle Detection System – Multiple Zones Each

7. GPS UNIT - GENERIC

7.1. DESCRIPTION

Furnish and install a GPS unit in the traffic signal cabinet for time synchronization in accordance with the plans and specifications. Comply with the provisions of Section 1700 of the Standard Specifications for Roads and Structures.

7.2. MATERIALS

Provide a GPS unit and antenna for time synchronization that supports the NMEA 0183 standard, version 2.1 or later, as defined by the National Marine Electronics Association. The GPS unit shall support the following NMEA standard sentences: RMC, GGA, GSA, GSV, GLL and ZDA. The unit shall have an update interval of at least once per minute. Ensure the unit operates properly over a temperature range of -34.6° F to +165.2° F.

For traffic signal installations, the GPS unit shall communicate to the 2070 controller unit via an RS-232 serial data port on the controller. Provide any necessary data converters (for example: RS-422 to RS-232 converter) to achieve communications to the controller unit from the GPS.

7.3. CONSTRUCTION METHODS

Mount the GPS antenna on the pole adjacent to the cabinet at a minimum height of 10’ ensuring that the antenna can acquire enough satellites to be accurate. Provide conduit with appropriate fittings for mounting the antenna and running the interface cable. Provide a GPS antenna interface cable that is not more than 50’ in length. Provide a drip loop in the cable before it enters the conduit. Ensure the cable entry point into the conduit is waterproof. If a pole is not within 30’ of the cabinet, the GPS antenna may be mounted to the top of the cabinet, while ensuring that the connection point into the cabinet is waterproof. Provide and install a data converter for connection between the GPS antenna and the 2070 controller unit as necessary.

7.4. MEASUREMENT AND PAYMENT

Actual number of GPS units furnished, installed, and accepted.

No measurement will be made for interface cables, conduit, data converters, and connectors, as these are considered incidental to furnishing and installing the GPS unit assemblies.

Payment will be made under:

GPS UnitEach

R-5799

TS-41

Transylvania County

8. METAL POLE SUPPORTS

8.1. METAL POLES

A. General:

Furnish and install metal poles, grounding systems, and all necessary hardware. Work covered under this special provision includes requirements for design, fabrication, and installation of standard and custom/site-specific designed metal pole supports and associated foundations.

Comply with applicable sections of the *2018 STANDARD SPECIFICATIONS FOR ROADS & STRUCTURES*, hereinafter referred to as the *Standard Specifications*. Provide designs of completed assemblies with hardware equaling or exceeding AASHTO *Standard Specifications for Structural Supports for Highway Signs, Luminaires and Traffic Signals* 6th Edition, 2013 (hereinafter called 6th Edition AASHTO), including the latest interim specifications. Provide assemblies with a round or near-round (18 sides or more) cross-section, or a multi-sided cross section with no less than six sides. The sides may be straight, convex, or concave.

For bid purposes, pole heights shown on plans are estimated from available data. Prior to furnishing metal poles, use field measurements and adjusted cross-sections to determine whether pole heights will meet required clearances. If pole heights do not meet required clearances, the Contractor should immediately notify the Engineer of the required revised pole heights.

Standard Drawings for Metal Poles are available that supplement these project special provisions. The drawings are located on the Department's website:

<https://connect.ncdot.gov/resources/safety/pages/ITS-Design-Resources.aspx>

Comply with article 1098-1B of the *Standard Specifications* for submittal requirements. Furnish shop drawings for approval. Provide copies of detailed shop drawings for each type of structure as summarized below. Ensure shop drawings include material specifications for each component. Ensure shop drawings identify welds by type and size on the detail drawing only, not in table format. **Do not release structures for fabrication until shop drawings have been approved by NCDOT.** Ensure shop drawings contain an itemized bill of materials for all structural components and associated connecting hardware.

Comply with article 1098-1A of the *Standard Specifications* for Qualified Products List (QPL) submittals. All shop drawings must include project location description, signal or asset inventory number(s) and project number or work order number.

Summary of information required for metal pole review submittal:

Item	Electronic Submittal	Comments / Special Instructions
Sealed, Approved Signal or ITS Plan/Loading Diagram	1 set	All structure design information needs to reflect the latest approved Signal or ITS plans
Custom Pole Shop Drawings	1 set	Submit drawings on 11" x 17" format media. Show NCDOT signal or asset inventory number(s), Contractor's name and relevant revision number in the title block. All drawings must have a <u>unique drawing number</u> for each project.
Standard Strain Pole Shop Drawings (from the QPL)	1 set	Submit drawings on 11" x 17" format media. Show NCDOT signal inventory number(s),

R-5799

TS-42

Transylvania County

		Contractor's name and relevant revision number in the title block. All drawings must have a <u>unique drawing number</u> for each project.
Structure Calculations	1 set	Not required for Standard QPL Poles
Standard Strain Pole Foundation Drawings	1 set	Submit drawings on 11" x 17" format media. Submit a completed Standard Foundation Selection form for each pole using foundation table on Metal Pole Drawing M8.
Custom Foundation Drawings	1 set	Submit drawings on 11" x 17" format media. Show NCDOT signal or asset inventory number(s), Contractor's name and relevant revision number in the title block. All drawings must have a <u>unique drawing number</u> for each project. If QPL Poles are used, include the corresponding QPL pole shop drawings with this submittal.
Foundation Calculations	1 set	Submit copies of LPILE input, output, and pile tip deflection graph per Section titled Drilled Pier Foundations for Metal Poles of this specification for each foundation. Not required for Standard Strain Poles (from the QPL)
Soil Boring Logs and Report	1 set	Report shall include a location plan and a soil classification report including soil capacity, water level, hammer efficiency, soil bearing pressure, soil density, etc. for each pole.

NOTE – All shop drawings and custom foundation design drawings must be sealed by a Professional Engineer licensed in the state of North Carolina. All geotechnical information must be sealed by either a Professional Engineer or Geologist licensed in the state of North Carolina. Include a title block and revision block on the shop drawings and foundation drawings showing the NCDOT signal or asset inventory number(s).

Shop drawings and foundation drawings may be submitted together or separately for approval. However, shop drawings must be approved before foundations can be reviewed. Foundation designs will be returned without review if the associated shop drawing has not been approved. Boring reports shall include the following: Engineer's summary, boring location maps, soil classification per AASHTO Classification System, hammer efficiency, and Metal Pole Standard Foundation Selection Form. Incomplete submittals will be returned without review. The Reviewer has the right to request additional analysis and copies of the calculations to expedite the approval process.

B. Materials:

Fabricate metal pole from coil or plate steel that meet the requirements of ASTM A 572 Gr 55 or ASTM A 595 Grade A tubes. For structural steel shapes, plates, and bars use, as a minimum, ASTM A572 Gr 50, AASHTO M270 Gr 50, ASTM A709 Gr 50, or an approved equivalent. Provide pole shafts of round or near round (18 sides or more) cross-section, or multi-sided tubular cross-section with no less than six sides, having a uniform linear taper of 0.14 in/ft. Construct shafts from one

piece of single-ply plate or coil. For anchor base fabrication, conform to the applicable bolt pattern and orientation as shown on Metal Pole Standard Drawing Sheet M2.

Use the submerged arc process, or other NCDOT previously approved process suitable for shafts, to continuously weld pole shafts along their entire length. Finish the longitudinal seam weld flush with the outside contour of the base metal. Ensure shaft has no circumferential welds except at the lower end joining the shaft to the pole base. Use full penetration groove welds with backing ring for all tube-to-transverse-plate connections in accordance with 6th Edition AASHTO. Provide welding that conforms to Article 1072-18 of the *Standard Specifications*. No field welding on any part of the pole will be permitted unless approved by a qualified Engineer.

After fabrication, hot-dip galvanize steel poles and all assembly components in accordance with section 1076-3 of the *Standard Specifications*. Design structural assemblies with weep holes large enough and properly located to drain molten zinc during the galvanization process. Galvanize hardware in accordance with section 1076-4 of the *Standard Specifications*. Ensure threaded material is brushed and retapped as necessary after galvanizing. Perform repair of damaged galvanizing in accordance with section 1076-7 of the *Standard Specifications*. Ensure all hardware is galvanized steel or stainless steel. The Contractor is responsible for ensuring the Designer/Fabricator specifies connecting hardware and/or materials that prevent a dissimilar metal corrosive reaction.

Ensure each anchor rod is 2-inch minimum diameter and 60-inch length. Provide 10-inch minimum thread projection at the top of the rod, and 8-inch minimum at the bottom of the rod. Use anchor rod assembly and drilled pier foundation materials complying with SP09_R005, hereinafter referred to as *Foundations and Anchor Rod Assemblies for Metal Poles*.

Ensure anchor bolt hole diameters are ¼-inch larger than the anchor bolt diameters in the base plate.

Provide a circular anchor bolt lock plate securing the anchor bolts at the embedded end with two (2) washers and two (2) nuts. Provide a base plate template matching the bolt circle diameter of the anchor bolt lock plate. Construct plates and templates from ¼-inch minimum thick steel with a minimum width of 4 inches. Hot-dip galvanizing is not required for both plates.

Provide four (4) heavy hex nuts and four (4) flat washers for each anchor bolt. For nuts, use AASHTO M291 grade 2H, DH, or DH3 or equivalent material. For flat washers, use AASHTO M293 or equivalent material. Ensure anchor bolts have required diameters, lengths, and positions, and will develop strengths comparable to their respective poles.

For each pole, provide a grounding lug with a ½-inch minimum thread diameter, coarse thread stud and nut that will accommodate #4 AWG ground wire. Ensure the lug is electrically bonded to the pole and is conveniently located inside the pole at the hand hole.

Provide a removable pole cap with stainless steel attachment screws for the top of each pole. Ensure cap is cast aluminum conforming to Aluminum Association Alloy 356.0F. Furnish cap attached to the pole with a sturdy stainless-steel chain that is long enough to permit cap to hang clear of the pole-top opening when cap is removed.

Where required by the plans, furnish couplings 42 inches above bottom of the pole base for mounting of pedestrian pushbuttons. Provide mounting points consisting of 1½-inch internally threaded half-couplings complying with the NEC, mounted within the poles. Ensure that couplings are essentially flush with the outside surfaces of the poles and are installed before any required hot-dip galvanizing. Provide a threaded plug in each mounting point. Ensure the surface of the plug is

essentially flush with the outer end of the mounting point when installed and has a recessed slot that will accommodate a ½ “drive standard socket wrench.

Metal poles may be erected and fully loaded after concrete has attained a minimum allowable compressive strength of 3,000 psi.

Connect poles to grounding electrodes and bond them to the electrical service grounding electrodes.

When field drilling is necessary for wire or cable entrances into the pole, comply with the following requirements:

- Do not drill holes within 2 inches of any welds.
- Do not drill any holes larger than 3 inches in diameter without checking with the ITS & Signals Structure Engineers.
- Avoid drilling multiple holes along the same cross section of tube shafts.
- Install rubber grommets in all field drilled holes that wire, or cable will directly enter unless holes are drilled for installation of weather heads or couplings.
- Treat the inside of the drilled holes and repair all galvanized surfaces in accordance with Section 1076-7 of the latest edition of the *Standard Specification prior to installing grommets, caps, or plugs*.
- Cap or plug any existing field drilled holes that are no longer used with rubber, aluminum, or stainless-steel hole plugs.

When street lighting is installed on metal signal structures, isolate the conductors feeding the luminaires inside the pole shaft using liquid tight flexible metal conduit (Type LFMC), liquid tight flexible nonmetallic conduit (Type LFNC), high density polyethylene conduit (Type HDPE), or approved equivalent. All conductors supplying power for luminaires must run through an external disconnect prior to entrance into the structure. Comply with applicable National Electrical Safety Codes (NEC). Refer to Article “G” Luminaire Arms.

Install a ¼-inch thick plate for a concrete foundation tag to include the following information: concrete grade, depth, diameter, and reinforcement sizes of the installed foundation. Install galvanized wire mesh to cover gap between the base plate and top of foundation for debris and pest control. Refer to standard drawing M7 for further details.

Immediately notify the Engineer of any structural deficiency that becomes apparent in any assembly, or member of any assembly, because of the design requirements imposed by these specifications, the plans, or the typical drawings.

C. Design:

Unless otherwise specified, design all metal pole support structures using the following 6th Edition AASHTO specifications:

- Design for a 50-year service life as recommended by Table 3.8.3-2.
- Use wind pressure map developed from 3-second gust speeds, as provided in Section 3.8.
- Assume wind loads as shown in Figures 3.9.4.2-2 and 3.9.4.2-3 of the 6th Edition AASHTO for Group III loading with Ice.
- Ensure metal pole support structures include natural wind gust loading and truck-induced gust loading for fatigue design, as provided in Sections 11.7.1.2 and 11.7.1.3, respectively. Designs need not consider periodic galloping forces.

- Assume 11.2 mph natural wind gust speed in North Carolina. For natural wind fatigue stress calculations, utilize a drag coefficient (C_d) based on the yearly mean wind velocity of 11.2 mph.
- When selecting Fatigue Importance Factors, utilize Fatigue Importance Category II, as provided for in Table 11.6-1, unless otherwise specified.
- Calculate all stresses using applicable equations from Section 5. The Maximum allowable stress ratio for all metal pole support designs is 0.9.
- Conform to Sections 10.4.2 and 11.8 for deflection requirements. For CCTV and MVD support structures, ensure maximum deflection at top of pole does not exceed 2.0 percent of pole height.
- Assume the combined minimum weight of a messenger cable bundle (including messenger cable, signal cable and detector lead-in cables) is 1.3 lbs/ft. Assume the combined minimum diameter of the cable bundle is 1.3 inches.

Unless otherwise specified by special loading criteria, the following computed surface area for ice load on signal heads shall be used:

- 3-section, 12-inch, Surface area: 26.0 ft²
- 4-section, 12-inch, Surface area: 32.0 ft²
- 5-section, 12-inch, Surface area: 42.0 ft²

Design a base plate for each pole. The minimum base plate thickness for all poles is determined by the following criteria:

Case 1 Circular or rectangular solid base plate with the upright pole welded to the top surface of base plate with full penetration butt weld, where no stiffeners are provided. A base plate with a small center hole, which is less than 1/3 of the upright diameter, and located concentrically with the upright pole, may be considered as a solid base plate.

The magnitude of bending moment in the base plate, induced by the anchoring force of each anchor bolt is $M = (P \times D_1) / 2$, where

M = bending moment at the critical section of the base plate induced by one (1) anchor bolt

P = anchoring force of each anchor bolt

D_1 = horizontal distance between the anchor bolt center and the outer face of the upright, or the difference between the bolt circle radius and the outside radius of the upright

Locate the critical section at the face of the anchor bolt and perpendicular to the bolt circle radius. The overlapped part of two (2) adjacent critical sections is considered ineffective.

Case 2 Circular or rectangular base plate with the upright pole socketed into and attached to the base plate with two (2) lines of fillet weld, and where no stiffeners are provided, or any base plate with a center hole that is larger in diameter than 1/3 of the upright diameter.

The magnitude of bending moment induced by the anchoring force of each anchor bolt is $M = P \times D_2$,

where P = anchoring force of each anchor bolt

D_2 = horizontal distance between the face of the upright and the face of the anchor bolt nut

Locate the critical section at the face of the anchor bolt top nut and perpendicular to the radius of the bolt circle. The overlapped part of two (2) adjacent critical sections is considered ineffective. If the base plate thickness calculated for Case 2 is less than Case 1, use the thickness calculated for Case 1.

The following additional requirements apply concerning pole base plates.

- Ensure that whichever case governs as defined above, the anchor bolt diameter is set to match the base plate thickness. If the minimum diameter required for the anchor bolt exceeds the thickness required for the base plate, set the base plate thickness equal to the required bolt diameter.
- For all metal poles, use a full penetration groove weld with a backing ring to connect the pole upright component to the base. Refer to Metal Pole Standard Drawing Sheet M3 or M4.

The Professional Engineer is wholly responsible for the design of all poles. Review and acceptance of these designs by the Department does not relieve the said Professional Engineer of his or her responsibility.

D. Strain Poles:

Refer to Metal Pole Standard Drawing Sheets M2 and M3 for fabrication details.

Provide two (2) messenger cable (span wire) clamps and associated hardware for attachment of messenger cable. Ensure diameter of the clamp is appropriate to its location on the pole and is appropriately designed for adjustment from 1'-6" below the top, down to 6'-6" below the top of the pole. Do not attach more than one (1) support cable to a messenger cable clamp.

Provide a minimum of three (3) 2-inch holes equipped with an associated coupling and weatherhead on the messenger cable load side of the pole to accommodate passage of signal cables from inside the pole. Provide galvanized threaded plugs for all unused couplings at pole entrance points. Refer to Metal Pole Standard Drawing Sheet M3 for fabrication details.

Provide designs with a 6" x 12" hand hole with reinforcing frame for each pole.

Provide a terminal compartment with cover and screws in each pole encompassing the hand hole and containing a 12-terminal barrier type terminal block. Provide two (2) terminal screws with a removable shorting bar between them for each termination. Furnish terminal compartment covers attached to the pole by a sturdy chain or cable approved by the Engineer. Ensure chain or cable is long enough to permit cover to hang clear of the compartment opening when cover is removed and is strong enough to prevent vandalism. Ensure chain or cable will not interfere with service to cables in the pole base.

Have poles permanently stamped above the hand holes with the identification tag details as shown on Metal Pole Standard Drawing Sheets M2 and M3.

Provide grounding lug(s) in the approximate vicinity of the messenger cable clamp for bonding and grounding messenger cable. Lugs must accept #4 AWG wire to bond messenger cables to the pole in order to provide an effective ground fault circuit path. Refer to Metal Pole Standard Drawing Sheet M6 for construction details.

Install metal poles, hardware, and fittings as shown on the manufacturer's installation drawings. Ensure the installed pole, when fully loaded, is within 1 degree 40 minutes (1°40') of vertical. Install poles with the manufacturer's recommended "rake." Where required, use threaded leveling nuts to establish rake.

8.2. DRILLED PIER FOUNDATIONS FOR METAL POLES

Analysis procedures and formulas shall be based on AASHTO 6th Edition, latest ACI-318 code and the *Drilled Shafts: Construction Procedures and Design Methods* FHWA-NHI-10-016 manual. Design methods based on engineering publications or research papers must have prior approval from NCDOT. The Department reserves the right to accept or reject any method used for the analysis.

Use the following Safety Factors for the foundation design:

- 1.0 x Service (Unfactored) Loads for LPile Shaft Lateral Deflection
- 1.3 x Torsion (Unfactored) Load for Drilled Shaft Concrete and Steel Strength
- (1.3 / 1.33) x Torsion (Unfactored) Load for Shaft Soil-to-Concrete Torsion Capacity
- (2.0 / 1.33) x Axial (Unfactored) Load for Shaft Axial Capacity in Soil

Ensure deflection at top of foundation does not exceed 1 inch for worst-case lateral load.

Use LPILE Plus V6.0 or later for lateral analysis. Submit inputs, results and corresponding graphs with the design calculations.

Calculate skin friction using the α -method for cohesive soils and the β -method for cohesion-less soils (**Broms method will not be accepted**). Detailed descriptions of the “ α ” and “ β ” methods can be found in *FHWA-NHI-10-016*.

Omit first 2.5 feet for cohesive soils when calculating skin friction.

Assume a hammer efficiency of 0.70 unless value is provided.

All CCTV and MVD pole drilled shafts shall be a minimum of 4’-0” diameter. Refer to Standard Drawing Nos. M7 and M8.

Design custom foundations to carry maximum capacity of each metal pole. For standard case strain poles with custom design, use actual shear, axial and moment reactions from the Standard Strain Pole Foundation Selection Table shown on Standard Drawing No. M8.

When poor soil conditions are encountered, which could create an excessively large foundation design, consideration may be given to allow an exemption to the maximum capacity design. The Contractor must gain approval from the Engineer before reducing a foundation’s capacity. On projects where poor soil is known to be present, the Contractor should have foundation designs approved before releasing poles for fabrication.

Have the Contractor notify the Engineer if the proposed foundation is to be installed on a slope other than 8H: 1V or flatter.

A. Description:

Furnish and install foundations for NCDOT metal poles with all necessary hardware in accordance with the plans and specifications.

Metal Pole Standards have been developed and implemented by NCDOT for use at signalized intersections in North Carolina. If the plans call for a standard strain pole, then a standard foundation may be selected from the plans. However, the Contractor is not required to use a standard foundation. If the Contractor chooses to design a non-standard site-specific foundation for a standard strain pole or if the plans call for a non-standard site-specific pole, design the foundation to conform to the applicable provisions in the NCDOT Metal Pole Standard Drawings and Section B4 (Non-Standard Foundation Design) below. If non-standard site-specific foundations are designed for standard QPL approved strain poles, the foundation designer must use the design moment specified by load case on Metal Pole Standard Drawing Sheet M8. Failure to conform to this requirement will be grounds for rejection of the design.

If the Contractor chooses to design a non-standard foundation for a standard strain pole and the soil test results indicate a standard foundation is feasible for the site, the Contractor will be paid the cost of the standard foundation. Any additional cost associated with a non-standard site-specific foundation including additional materials, labor and equipment will be considered incidental to the cost of the standard foundation. All costs for the non-standard foundation design will be considered incidental to the cost of the standard foundation.

B. Soil Test and Foundation Determination:

1. General:

Drilled piers are reinforced concrete sections, cast-in-place against in situ, undisturbed material. Drilled piers are of straight shaft type and vertical.

2. Soil Test:

Perform a soil test at each proposed metal pole location. Complete all required fill placement and excavation at each pole location to finished grade before drilling each boring. Soil tests performed that are not in compliance with this requirement may be rejected and will not be paid. Drill one boring to a depth of 26 feet within a 25-foot radius of each proposed foundation.

Perform standard penetration tests (SPT) in accordance with ASTM D 1586 at depths of 1, 2.5, 5, 7.5, 10, 15, 20 and 26 feet. Discontinue the boring if one of the following occurs:

- A total of 100 blows have been applied in any two consecutive 6-inch intervals.
- A total of 50 blows have been applied with < 3-inch penetration.

Describe each pole location along the project corridor in a manner that is easily discernible to both the Contractor's Designer and NCDOT Reviewers. If the pole is at an intersection, label the boring the "Intersection of (Route or SR #), (Street Name) and (Route or SR #), (Street Name), _____ County, Signal or Asset Inventory No. _____". Label borings with "B- N, S, E, W, NE, NW, SE or SW" corresponding to the quadrant location within the intersection.

If the pole location is located between intersections, provide a coordinate location and offset, or milepost number and offset. Pole numbers should be made available to the Drill Contractor. Include pole numbers in the boring label if they are available. If they are not available, ensure the boring labels can be cross-referenced to corresponding pole numbers. For each boring, submit a legible (hand-written or typed) boring log signed and sealed by a licensed Geologist or Professional Engineer registered in North Carolina. Include on each boring the SPT blow counts and N-values at each depth, depth of the boring, hammer efficiency, depth of water table and a general description of the soil types encountered using the AASHTO Classification System.

Borings that cannot be easily correlated to their specific pole location will be returned to the Contractor for clarification; or if approved by the Engineer, the foundation may be designed using the worst-case soil condition obtained as part of this project.

3. Standard Foundation Determination:

Use the following method for determining the Design N-value:

$$N_{AVG} = \frac{N_{@1'} + N_{@2.5'} + \dots + N_{@Deepest\ Boring\ Depth}}{Total\ Number\ of\ N\ values}$$

$$Y = (N_{@1'})^2 + (N_{@2.5'})^2 + \dots + (N_{@Deepest\ Borin\ Dep})^2$$

$$Z = N_{@1'} + N_{@2.5'} + \dots + N_{@Deepest\ Boring\ Dept}$$

$$N_{STD\ DEV} = \sqrt{\left(\frac{(Total\ Number\ of\ N\ values \times Y) - Z^2}{(Total\ Number\ of\ N\ values) \times (Total\ Number\ of\ N\ values - 1)} \right)}$$

Design N-value equals lesser of the following two conditions:

$$N_{AVG} - (N_{STD\ DEV} \times 0.45)$$

OR

$$Average\ of\ First\ Four\ (4)N\ values = \frac{N_{@1'} + N_{@2.5'} + N_{@5'} + N_{@7.5'}}{4}$$

Note: If less than four (4) N-values are obtained because of criteria listed in Section 2 above, use average of N-values collected for second condition. Do not include the N-value at the deepest boring depth for above calculations if the boring is discontinued at or before the required boring depth because of criteria listed in Section 2 above. Use N-value of zero (0) for weight of hammer or weight of rod. If N-value is greater than fifty (50), reduce N-value to fifty (50) for calculations.

If standard NCDOT strain poles are shown on the plans and the Contractor chooses to use standard foundations, determine a drilled pier length, “L,” for each signal pole from the Standard Strain Pole Foundations Chart (sheet M8) based on the Design N-value and the predominant soil type. For each standard pole location, submit a completed “Metal Pole Standard Foundation Selection Form” signed by the Contractor’s representative. Signature on form is for verification purposes only. Include the Design N-value calculation and resulting drilled pier length, “L,” on each form.

If non-standard site-specific poles are shown on the plans, submit completed boring logs collected in accordance with Section 2 (Soil Test) along with pole loading diagrams from the plans to the Contractor-selected pole Fabricator to assist in the pole and foundation design.

If one of the following occurs, the Standard Foundations Chart shown on the plans may not be used and a non-standard foundation may be required. In such case, contact the Engineer.

- The Design N-value is less than four (4).
- The drilled pier length, “L”, determined from the Standard Foundations Chart, is greater than the depth of the corresponding boring.

In the case where a standard foundation cannot be used, the Department will be responsible for the additional cost of the non-standard foundation.

Foundation designs are based on level ground around the traffic signal pole. If the slope around the edge of the drilled pier is steeper than 8:1 (H:V) or the proposed foundation will be less than 10 feet from the top of an embankment slope, the Contractor is responsible for providing slope information to the foundation Designer and to the Engineer so it can be considered in the design.

The “Metal Pole Standard Foundation Selection Form” may be found at:

<https://connect.ncdot.gov/resources/safety/Pages/ITS-Design-Resources.aspx>

If assistance is needed, contact the Engineer.

4. Non-Standard Foundation Design:

Design non-standard foundations based upon site-specific soil test information collected in accordance with Section 2 (Soil Test). Design drilled piers for side resistance in accordance with Section 4.6 of the *2002 AASHTO Standard Specifications for Highway Bridges, 17th Edition*. Use computer software LPILE version-6.0 or later manufactured by Ensoft, Inc. to analyze drilled piers. Use computer software gINT V8i or later manufactured by Bentley Systems, Inc. with the current NCDOT gINT library and data template to produce SPT boring logs. Provide a drilled pier foundation for each pole with a length and diameter resulting in horizontal lateral movement less than 1 inch at top of the pier, and horizontal rotational movement less than 1 inch at the edge of pier. Contact the Engineer for pole loading diagrams of standard poles used for non-standard foundation designs. Submit non-standard foundation designs including drawings, calculations, and soil boring logs to the Engineer for review and approval before construction.

C. Drilled Pier Construction:

Construct drilled pier foundation and Install anchor rod assemblies in accordance with the *Foundations and Anchor Rod Assemblies for Metal Poles* Standard Special Provision SP09-R005 located at:

<https://connect.ncdot.gov/resources/Specifications/Pages/2018-Specifications-and-Special-Provisions.aspx>

8.3. METAL POLE REMOVALS

A. Description:

Remove and dispose of existing metal support poles, and remove and dispose of existing foundations, associated anchor bolts, electrical wires and connections.

B. Construction Methods:

1. Foundations:

Remove and promptly dispose of the metal support pole foundations including reinforcing steel, electrical wires, and anchor bolts to a minimum depth of 2 feet below the finished ground elevation. At the Contractor's option, remove the complete foundation.

2. Metal Poles:

Consult Division Traffic Services regarding ownership of poles. If the Division chooses to maintain these structures in their inventory for future use, permanently mark the pole with the signal inventory number, asset inventory number or some identifying information that identifies where the pole came from

Remove the metal support poles, and promptly transport the metal support poles from the project. Use methods to remove the metal support poles and attached equipment that will not result in damage to other portions of the project or facility. Repair damages that are a result of the Contractor's actions at no additional cost to the Department.

Transport and properly dispose of the materials.

Backfill and compact disturbed areas to match the finished ground elevation. Seed unpaved areas.

Use methods to remove the foundations that will not result in damage to other portions of the project or facility. Repair damages that are a result of the Contractor's actions at no cost to the Department.

R-5799

TS-51

Transylvania County

8.4. POLE NUMBERING SYSTEM

A. New Poles

Attach an identification tag to each pole shaft section as shown on Metal Pole Standard Sheet M2
“Typical Fabrication Details for All Metal Poles.”

8.5. MEASUREMENT AND PAYMENT

Actual number of metal strain signal poles (without regard to height or load capacity) furnished,
installed and accepted.

Actual number of metal signal poles removed and disposed.

Actual number of soil tests with SPT borings drilled furnished and accepted.

Actual volume of concrete poured in cubic yards of drilled pier foundation furnished, installed
and accepted.

No measurement will be made for foundation designs prepared with metal pole designs, as these
will be considered incidental to designing Traffic Signal support structures.

Payment will be made under:

Metal Strain Signal Pole	Each
Metal Pole Removal.....	Each
Soil Test	Each
Drilled Pier Foundation.....	Cubic Yard

9. PROTECTIVE COATING FOR METAL POLES

9.1. DESCRIPTION

Protective coating for metal poles is a supplemental durable color coating that is applied to galvanized steel and aluminum traffic signal structures installed in locations where maintaining an aesthetic appearance is important. Powder Coating is the preferred supplemental protective coating process for coating galvanized steel and aluminum structures. However, for the purposes of this special provision, an Acrylic Primer and topcoat paint system is included as an acceptable alternative when protective color coating is required.

Provide protective black coating over galvanization for all steel poles including all necessary hardware in accordance with the plans and specifications. Any aluminum components do not need to be galvanized before application of protective coating.

9.2. MATERIALS

With the exception of aluminum components, furnish all metal poles with galvanic protection along with a tough and durable application of protective coating. Aluminum components shall have a durable powder coating application. Galvanization is not required for aluminum components.

Furnish pole caps that have a low gloss powder finish applied over a hot-dipped galvanized surface. Comply with the applicable provisions of Section 442-10 and 442-13 of the 2018 *Standard Specifications*.

Ensure the selected color for protective coating has been verified and approved by the Engineer prior to fabrication.

9.3. COATING SHOP APPROVAL

Approve the coating shop facility prior to the application of any coating process. Submit all requests, procedures, and documents electronically to:

- Mr. Cabell Garbee, P.E., Manufactured Products Engineer
- cgarbee@ncdot.gov

A) Submit a quality control procedure that the company has established to ensure a quality and durable coating. The quality control procedure shall contain at a minimum the following:

- Qualified / Certified personnel to manage the QC Program and to conduct Quality Control tests
- Qualified / certified coaters
- Source and type of powder
- How the powder will be stored
- Powder application facility (heated or unheated)
- Surface pre-treatment
- Surface preparation including profile
- Application methods
- Curing conditions (conventional or infrared)
- Curing Temperature
- Adhesion & Holiday Detection

R-5799**TS-53****Transylvania County**

- Repair Procedure
 - Storage and protection of coated items
 - Shipping and handling (packing, protection, and wrapping)
- B) Submit a powder certification from the manufacturer
- C) Submit the following to the Chemical Testing Engineer a minimum of four weeks prior to coating application.
1. Two test panels of ASTM A36 steel, ¼ or greater in thickness measuring 8 inches by 11 inches using the proposed color of the final coat; a powder coated over galvanized test panel and a powder coated over un-galvanized test panel.
 2. In addition, provide two (2) samples of the same or comparable material and thickness as production pieces. Ensure production piece replicas do not exceed twelve inches (12”) in length and width nor 50 pounds in weight.
 3. Submit all test panels with inspection reports and records according to *Standard Specifications*, Section 442, Section 1072, Section 1076, and Section 1080.
 4. Acceptance of the panels is determined by meeting the requirements of ASTM D-4541 of 800 psi for both galvanized and un-galvanized and production piece test panels.
 5. Send all panels to:

Materials and Tests Unit
1801 Blue Ridge Road
Raleigh, NC 27607
Attn: Chemical Testing Engineer

9.4. POWDER COATING

A. Galvanizing

Galvanize steel products in accordance with Section 1076 of the Standard Specifications. Ensure the fabricator or designated representative(s) that is supplying the components to be galvanized communicates with the galvanizer to indicate that the galvanized pieces will be powder coated to avoid water or chromate quenching.

B. Surface Preparation

Comply with manufacturer's recommended surface coating specifications, Steel Structure Painting Council (SSPC) specifications and applicable articles of Section 442 (Painting Steel Structures) of the Standard Specifications. Ensure that surface preparations and treatments are performed and meet the requirements of the above referenced specifications.

Some pole components, specifically steel plates ¾ inches or more in thickness, may need blast cleaning prior to structure assembly to remove impurities and non-metallic foreign materials. Mechanically remove all weld flux after structure is assembled

Degrease and prepare steel structure for zinc coating after assembly using full immersion baths and pickling processes in heat controlled caustic and acid solutions. Rinse and clean structure to remove caustic or acid solutions by immersion in a circulating fresh water bath. Immerse structure in a heat controlled concentrated zinc ammonium chloride flux solution and air dry as a final prep before hot-dip galvanization.

Ensure that the surface preparation is no less than specified by the powder manufacturer's recommendations. Prepare all components to be coated in accordance with SSPC SP-2 (Hand Tool Cleaning) and/or SSPC SP-3 (Power Tool Cleaning). Remove all drainage spikes, high spots, protrusions or other surface defects using hand or power tools. Do not remove the galvanization below the limits set forth in AASHTO M111.

Remove grease, oils, moisture, scale, rust or any other foreign matter prior to powder coating to ensure ideal adhesion and coating performance. Prepare and coat the galvanized surface as soon as possible after the galvanization process.

C. Powder Coating Application and Curing

Prepare galvanized finish for powder coating by brush blasting in accordance with SSPC-SP7. Ensure all threaded components of the structure are protected from damage during blasting process.

Use thermosetting powder resin that meets 5A or 5B classifications of ASTM D3359. Apply powder coating electrostatically. Follow manufacturer's recommended preheating requirements. Ensure the topcoat finish is applied uniformly to all surfaces with a dry film thickness of between 3.0 to 5.0 mils. Cure the topcoat by heating the structure to manufacturer recommended temperatures at the duration required to ensure complete and uniform bond.

D. Quality Control

Ensure the applicator provides all test reports and documentation and inspects all coated material as outlined in the Standard Specifications, Section 442, Section 1072, Section 1076, and Section 1080. Ensure the quality control inspection is kept separate from the production functions.

E. Storage, Shipping, and Handling

Store all powder coated material inside or as directed by the Engineer.

Protect the product from incurring damage during all shipping, handling, and storing activities. Do not store the product directly on the ground or in areas where water may pool; the Engineer determines the effectiveness of all storage, shipping and handling methods.

F. Repair of Powder Coated Material

Repair all damage to the coating by the original method of application as outlined in the coating facility's repair procedure. Ensure all repair areas meet the original requirements for adhesion as stated in this Project Special Provision.

Photograph, document, and report all damages upon delivery to the project site prior to unloading. Provide documented damage notifications to the Engineer or to their authorized representative so the application firm can be notified. The Engineer has the authority to accept or reject the material as outlined in the Standard Specifications.

Submit to the Engineer a repair procedure for damaged coatings which occur during storage, transporting, handling and or installation. Utilize a liquid paint approved by the Department, compatible with the powder applied product. Ensure all repair areas demonstrate an adhesion rating of 400 psi in accordance with ASTM D-4541. Obtain Engineer's acceptance of the final finish.

9.5. ACRYLIC PRIMER AND TOPCOAT PAINT SYSTEM

A. Description

Follow NCDOT procedures for Powder Coating over Galvanizing. Provide an Acrylic Primer and topcoat when a substitute for powder coating is necessary.

R-5799**TS-55****Transylvania County**

Provide supplemental coating for all mast arms with metal signal poles and all necessary hardware for the signalized intersection in accordance with the Structural Steel Shop Coatings Program, NCDOT Standard specifications – sections 442 and 1080, as contained herein, and as shown on the plans. The Structural Steel Shop Coatings Program can be found at the following link: <https://connect.ncdot.gov/resources/Materials/MaterialsResources/Structural%20Steel%20Shop%20Coatings%20Program.pdf>

Ensure all painting work for new structures, except field touch-up and bolt painting is performed in the shop.

Coatings Shop Approval

Use only NCDOT approved shop coating facilities meeting the requirements outlined in the current edition of the Structural Steel Shop Coatings Program. This program is available on the Materials and Tests website.

Provide shop certification in accordance with the Structural Steel Shop Coatings Program (Shop facilities that are currently certified and in good standing with the American Institute Steel Construction (AISC) / Sophisticated Paint Endorsement (SPE) and/or the Society of Protective Coatings (SSPC) Qualification Procedure Three (QP-3).

B. Surface Preparation

Ensure all surface preparation is not less than that specified by the paint manufacturer's recommendations.

Clean galvanized surfaces to be painted with a 2,500 psi pressure washer. Allow surfaces to dry completely before beginning surface preparation.

Ensure all components to be coated are prepared in accordance with SSPC SP2 (Hand Tool Cleaning and or SSPC SP-3 (Power Tool Cleaning). Smooth high spots and rough edges, such as metal drip lines, of galvanized surfaces in accordance with ASTM D6386. Do not remove the galvanization below the limits set forth in AASHTO M111.

Perform abrasive sweep blasting in accordance with ASTM D6386. Refer to this section for a description of the abrasive blast material to be used. Use a material and technique capable of stripping action to remove corrosion products and to provide a rough surface profile while leaving base zinc layers intact.

Blow down all blasted surfaces with clean compressed air to provide a clean, dry surface.

Ensure all surfaces are free of visible zinc oxides or zinc hydroxides.

R-5799**TS-56****Transylvania County****C. Materials**

Use an approved/qualified waterborne paint meeting the requirements of NCDOT Standard specification section 1080. Do not apply paint until each batch has been tested by the Department. Provide color as specified in the contract documents.

Ensure all paint used on this contract is produced by the same manufacturer.

D. Painting

Apply paint in accordance with the requirements of the Structural Steel Shop Coatings Program, Section 442 and Section 1080 of the *Standard Specifications* as modified herein.

**System for Paint over Galvanize
Acrylic Primer and Topcoats**

Coat	Material	Mils Dry/Wet Film	Mils Dry/Wet Film
		Thickness	Thickness
		Minimum	Maximum
Primer	1080-9 White	3.0 DFT	5.0 DFT
Stripe	1080-9 *	4.0 WFT	7.0 WFT
Topcoat	1080-9 *	2.0 DFT	4.0 DFT
Total		5.0 DFT	9.0 DFT

***Ensure the selected color for protective coating has been verified and approved by the Engineer prior to fabrication.**

The time between blast and coating application shall be in accordance with ASTM D6386 time requirements. In no case shall the prepared surface extend beyond 8 hours.

Mask off and do not paint all data plates and faying surfaces prior to application.

Spray apply all coatings except for the stripe coat. Brush apply the stripe coat to all plate edges, welds, bolt holes and bolts prior to applying the finish coat.

E. Curing

Follow manufacturer recommendations.

F. Inspection

Quality Control shall conduct the required quality control tests as outlined in the Structural Steel Shop Coatings Program and report the minimum information required by the appropriate ASTM test methods. At a minimum, quality control forms shall be on company letterhead with logo that provides a daily inspection report form equivalent to the information required on the M&T-611 Form. The M&T-611 Form can be found in the Structural Steel Shop Coatings Program. Dry Film Thickness (DFT) measurements shall be obtained on all coating layers, including the galvanized layer and shall incorporate the use of a Type 2 gauge as defined in SSPC PA-2.

Ensure all material is of a uniform appearance free of runs, drips, and sags.

R-5799

TS-57

Transylvania County

G. Handling

Do not handle, ship, or erect coated members until paint is thoroughly dry.

Protect all shipping and handling either from the coating facility to project site and or storage site to area(s) to construction location from incurring damage to product. Wood blocks and nylon slings are recommended for securing, loading, hoisting or storing members.

H. Repair of Damaged Coating

Repair damage occurring to the galvanized portion of the coating during shipment or installation in accordance with Articles 1076-7 and 1080-7 of the *Standard Specifications*. Repair damage occurring to the painted portion of the coating during shipment or installation by applying 4.0-7.0 wet mils of topcoat with a brush or roller and feather or taper this to be level with the surrounding areas.

9.6. MEASUREMENT AND PAYMENT

Actual number of strain poles with protective coating applied furnished, installed, and accepted.

Actual number of signal pedestals with protective coating applied furnished, installed, and accepted.

Actual number of pushbutton posts with protective coating applied furnished, installed, and accepted.

Payment will be made under:

Protective Coating for Strain Pole (_____)	Each
Protective Coating for Signal Pedestal (_____)	Each
Protective Coating for Pushbutton Post (_____)	Each

10. RECTANGULAR RAPID FLASHING BEACON SOLAR POWERED DISPLAY AND CONTROLLER ASSEMBLY

10.1. DESCRIPTION

Provide rectangular rapid flashing beacon (RRFB) that is solar powered and pedestrian activated. Ensure the RRFB consist of two rapidly flashing rectangular-shaped yellow indications, solar panel, battery, controller assembly and all necessary hardware. Ensure multiple RRFB units at a given crosswalk are synchronized.

Ensure the RRFB meets the physical display and operational requirements in the interim approval for RRFB by the Federal Highway Administration; see requirements at https://mutcd.fhwa.dot.gov/resources/interim_approval/ia21/ia21.pdf.

Ensure the RRFB meets the full requirements as noted in the subsequent Official Interpretations issued by the Federal Highway Administration.

10.2. MATERIALS

Comply with Section 1094 of the 2018 Standard Specifications for Roads and Structures for ground mounted sign supports. Unless otherwise shown on the plans, Three Pound Steel U-Channel Posts shall be used for mounting the rectangular rapid flashing beacon assembly.

Provide two rapid flashing yellow indications that are aligned horizontally in a single housing with a space between both indications of a minimum of 7" from inside edge of one indication to inside edge of the other indication. Ensure each indication is rectangular-shaped and has minimum dimensions of 5" wide by 2" high. Provide a Light Emitting Diode (LED) array for each indication. Provide Independent Laboratory Certification and test results for each indication facing motorists as evidence that the light intensity meets the Class 1 requirements for of the Society of Automotive Engineers (SAE) standard J595 (Directional Flashing Optical Warning Devices for Authorized Emergency, Maintenance, and Service Vehicles) dated November 2008. Provide an aluminum housing that can be attached to a 4.5" OD pedestal pole. Powder coat the housing with an electrostatically applied, fused-polyester paint in highway yellow (Federal Standard 595C, Color Chip Number 13538) a minimum of 2.5 to 3.5 mils thick. Ensure the housing does not project beyond the outside edges of a W11-2 or S1-1 sign. Ensure the two indications are installed into the housing assembly to face in the direction of the approaching vehicular traffic. When specified, provide two additional identical indications for the motorists in a similar constructed housing that can be attached on the opposite side of the pole.

Provide the two yellow indications facing motorists to flash in a rapidly alternating "wig-wag" flashing sequence (left light on, then right light on). Ensure 70 to 80 periods of flashing per minute with the left indication emitting two slow pulses of light and the right indication emitting four rapid pulses of light followed by a long pulse of light. Ensure the indications have approximately equal periods of rapid pulsing light emissions and dark operation. Ensure flash rates are not at frequencies between 5 and 30 flashes per second to avoid flash-induced seizures. Provide a flashing yellow LED indication on the end of the housing to provide notification of activation and operation of the device to pedestrians in the crosswalk.

During operation, ensure the RRFB remains dark until a pedestrian actuation occurs and then returns back dark at a programmed time after the pedestrian activation. Provide wireless communication equipment to ensure all RRFBs associated at a given crosswalk simultaneously start operation of their alternating rapid flashing indications when activated and cease operation simultaneously. Provide a means to prevent interference with other systems utilizing similar communications equipment.

Provide a 12VDC sealed gel, sealed lead acid, or absorption glass mat battery with sufficient capacity for 5 days of 3 hours of continuous operation with no additional charge from solar panel. Ensure the battery is located in a moisture and corrosion resistant enclosure. Provide a solar panel with a minimum array-to-load ratio of 1.2 and charging circuitry for the battery. Provide a solar sizing report that shows the system loss of load probability is 0% for the entire year for Raleigh, North Carolina. Provide mounting hardware to allow solar panel to be tilted at least 45 degrees from horizontal and panned 360 degrees.

Provide stainless steel fasteners for all items exposed to the weather. For fasteners protected from the weather, provide fasteners fabricated from stainless steel or other corrosion-resistant materials.

Ensure assemblies provide protection from environmental conditions and accidental contact equivalent to a NEMA 3R-rated enclosure. Ensure all components operate properly within the following limits unless otherwise noted:

- Humidity: 5% to 95%, non-condensing
- Ambient Temperature: -30.0°F to +165°F
- Shock - NEMA TS2-2003, Section 2.1.10
- Vibration - NEMA TS2-2003, Section 2.1.9

10.3. CONSTRUCTION METHODS

For each approach to the RRFB location, use two RRFB assemblies, installed at the crosswalk, one on the right-hand side of the roadway and one on the left-hand side of the roadway. On a divided highway, install the left-hand side assembly in the median, if practical, rather than on the far-left side of the highway. Each RRFB assembly shall consist of a W11-2 (Pedestrian) or S1-1 (School) crossing warning sign, a RRFB, and W16-7p (downward diagonal arrow) plaque. Install the RRFB on the same support as the associated W11-2 (Pedestrian) or S1-1 (School) crossing warning sign and plaque. Do not install an RRFB independent of the crossing signs for the approach the RRFB faces.

Ensure that the outside edges of the RRFB indications, including any housings, do not project beyond the outside edges of the W11-2 or S1-1 sign. Locate the RRFB between the bottom of the crossing warning sign and the top of the supplemental W16-7p plaque, rather than 12 inches above or below the sign assembly.

If using pushbuttons to activate the RRFBs (versus passive detection), install the pushbutton assembly below the RRFB and W16-7p plaque. Mount the pushbutton at a minimum height of 3.5 feet but no higher than 4.0 feet above the adjacent pedestrian travel way. With pushbutton activation, mount a pedestrian instructional sign with legend “PUSH BUTTON TO TURN ON WARNING LIGHTS” adjacent to or integral with each pedestrian pushbutton.

Obtain flashing duration to be programmed into the RRFB from the Engineer.

10.4. MEASUREMENT AND PAYMENT

Actual number of rectangular rapid flashing beacon assemblies furnished, installed, and accepted.

No measurement will be made of rapidly flashing rectangular-shaped yellow indications, solar panel, battery, controller assembly, mounting posts, and all necessary hardware as these items will be considered incidental to furnishing and installing rectangular rapid flashing beacon assemblies.

Payment will be made under:

Rectangular Rapid Flashing Beacon AssemblyEach

11. CELLULAR MODEMS FOR COMMUNICATIONS

11.1. DESCRIPTION

For equipment cabinets designated to communicate via a DOT furnished cellular modem, install cellular modems provided by the Department to establish a communications link to the Traffic Operations Center.

11.2. MATERIALS

A. Obtaining Cellular Modem:

To obtain cellular modems in a timely manner make request to the Engineer a minimum of 8 (eight) weeks in advance of deployment. Cellular modems will be provided with all necessary network configuration data and IP addressing for plug-and-play operations. Cellular modems will be supplied with a power supply, antenna with coaxial cabling, nuts and washers for installation by the Contractor.

B. Cellular Modem Antenna Mounting Bracket:

Fabricate, furnish and install an L-Shaped mounting bracket to be secured to the outside of the cabinet to hold the cellular modem antenna. Design the L-Shape bracket out of 5052-H32 aluminum that is 0.125" thick by 3" wide by 6" long. Place a 90-degree bend along the 6" axis at ½ its length. Provide two ¼" mounting holes on one side of the L-Bend and provide 1/4" stainless-steel bolts, washers and nuts, for mounting the L-Bracket to the outside of the cabinet. On the other half of the bracket provide a 5/8" hole centered in the plate to accept the cellular antenna and coaxial cable.

11.3. CONSTRUCTION METHODS

A. Cellular Modem:

Mount the modem in the cabinet so as not to interfere with access or visually inspecting other equipment located in the cabinet. Arrange all cables (power, antenna and network cables) in a neat workmanship like manner. Use zip ties or other means to neatly route and secure the various cables so they are not subject to becoming pinched in the cabinet doors or be subject to fraying as they bend around objects in the cabinet interior. Secure the modem in a manner approved by the Engineer.

B. Cellular Modem Antenna Mounting Bracket:

File drill mounting holes in the cabinet to match up with the bracket mounting holes. Drill one (1) additional 5/8" hole centered under the bracket into the side of the cabinet to provide an entryway for the antenna's coaxial cable. For all drilling operations that require field manufacturing of holes in a cabinet shell, ensure caution is taken to not allow metal shavings to fall into or on equipment inside the cabinet.

Prior to mounting the L-Bracket to the cabinet, run a ¼" bead of silicon calk near the back-top area of the L-Bracket and around each field drilled ¼" cabinet mounting holes. Install stainless steel bolts, washers and nuts and secure the bracket to the cabinet. Install the coaxial antenna cable through the cable gland (Bud Industries – Nylon Cable Gland: Part No: NG-9512, or equivalent) and into the cabinet. If necessary, lightly ream the nylon compression nut opening for insertion of the RG-58 antennae hex nut and coaxial cable. Tighten the cable gland to the cabinet shell and tighten the compression nut on the nylon cable gland to provide a water-tight seal around the coaxial antenna cable.

Reference the drawing below for additional details regarding the Mounting Bracket construction and mounting.

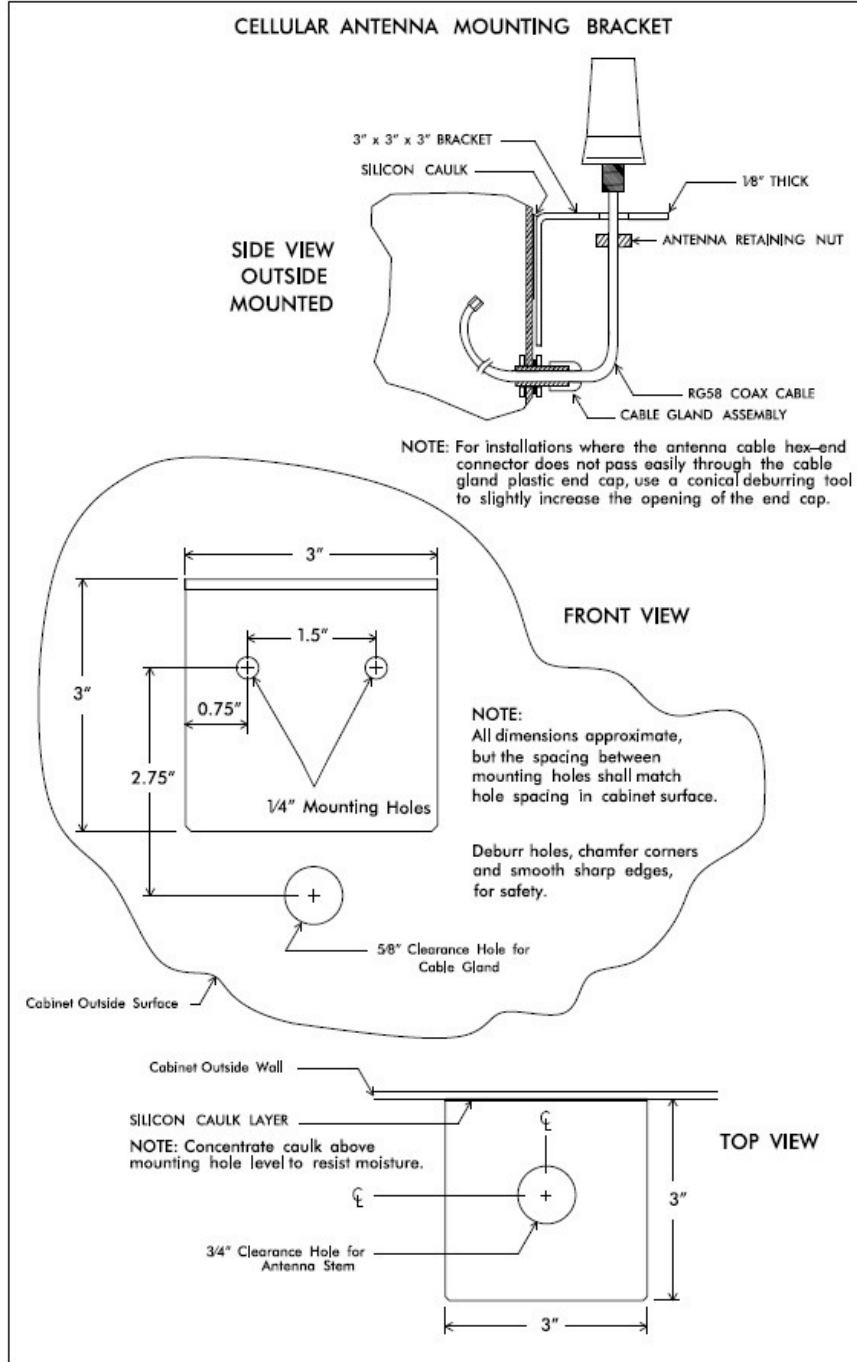

11.4. MEASUREMENT AND PAYMENT

No measurement will be made for installing the “Cellular Modem” as it will be considered incidental to the installation of the ITS device or traffic signal the Cellular Modem is being integrated with. This includes but is not limited to the fabrication and installation of the cellular antenna mounting bracket, cable glands, silicon-caulk, zip-ties, bolts, nuts and washers or labor required to install the cellular modem.

Project R-5799

ST-1

Transylvania County

Project Special Provisions

Culvert

<u>Table of Contents</u>	Page #
FALSEWORK AND FORMWORK (2-14-22).....	ST-2
SUBMITTAL OF WORKING DRAWINGS (2-14-22).....	ST-9
CRANE SAFETY (6-20-19).....	ST-15
GROUT FOR STRUCTURES (12-1-17).....	ST-16

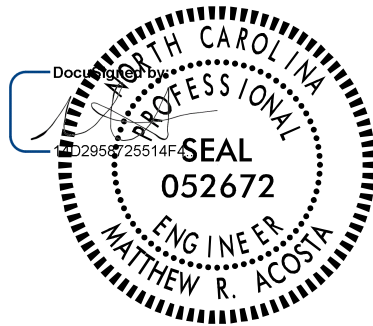

5/3/2023

FALSEWORK AND FORMWORK**(2-14-22)****1.0 DESCRIPTION**

Use this Special Provision as a guide to develop temporary works submittals required by the Standard Specifications or other provisions; no additional submittals are required herein. Such temporary works include, but are not limited to, falsework and formwork.

Falsework is any temporary construction used to support the permanent structure until it becomes self-supporting. Formwork is the temporary structure or mold used to retain plastic or fluid concrete in its designated shape until it hardens. Access scaffolding is a temporary structure that functions as a work platform that supports construction personnel, materials, and tools, but is not intended to support the structure. Scaffolding systems that are used to temporarily support permanent structures (as opposed to functioning as work platforms) are considered to be falsework under the definitions given. Shoring is a component of falsework such as horizontal, vertical, or inclined support members. Where the term “temporary works” is used, it includes all of the temporary facilities used in bridge construction that do not become part of the permanent structure.

Design and construct safe and adequate temporary works that will support all loads imposed and provide the necessary rigidity to achieve the lines and grades shown on the plans in the final structure.

2.0 MATERIALS

Select materials suitable for temporary works; however, select materials that also ensure the safety and quality required by the design assumptions. The Engineer has authority to reject material on the basis of its condition, inappropriate use, safety, or nonconformance with the plans. Clearly identify allowable loads or stresses for all materials or manufactured devices on the plans. Revise the plan and notify the Engineer if any change to materials or material strengths is required.

3.0 DESIGN REQUIREMENTS**A. Working Drawings**

Provide working drawings for items as specified in the contract, or as required by the Engineer, with design calculations and supporting data in sufficient detail to permit a structural and safety review of the proposed design of the temporary work.

On the drawings, show all information necessary to allow the design of any component to be checked independently as determined by the Engineer.

When concrete placement is involved, include data such as the drawings of proposed sequence, rate of placement, direction of placement, and location of all construction joints.

Project R-5799

ST-3

Transylvania County

When required, have the drawings and calculations prepared under the guidance of, and sealed by, a North Carolina Registered Professional Engineer who is knowledgeable in temporary works design.

If requested by the Engineer, submit with the working drawings manufacturer's catalog data listing the weight of all construction equipment that will be supported on the temporary work. Show anticipated total settlements and/or deflections of falsework and forms on the working drawings. Include falsework footing settlements, joint take-up, and deflection of beams or girders.

As an option for the Contractor, overhang falsework hangers may be uniformly spaced, at a maximum of 36 inches, provided the following conditions are met:

Member Type (PCG)	Member Depth, (inches)	Max. Overhang Width, (inches)	Max. Slab Edge Thickness, (inches)	Max. Screenshot Wheel Weight, (lbs.)	Bracket Min. Vertical Leg Extension, (inches)
II	36	39	14	2000	26
III	45	42	14	2000	35
IV	54	45	14	2000	44
MBT	63	51	12	2000	50
MBT	72	55	12	1700	48

Overhang width is measured from the centerline of the girder to the edge of the deck slab. For Type II, III & IV prestressed concrete girders (PCG), 45-degree cast-in-place half hangers and rods must have a minimum safe working load of 6,000 lbs.

For MBT prestressed concrete girders, 45-degree angle holes for falsework hanger rods shall be cast through the girder top flange and located, measuring along the top of the member, 1'-2 1/2" from the edge of the top flange. Hanger hardware and rods must have a minimum safe working load of 6,000 lbs.

For links slabs, the tops of girders directly beneath the link slab shall be free of overhang falsework attachments or other hardware. Submit calculations and working drawings for overhang falsework in the link slab region.

The overhang bracket provided for the diagonal leg shall have a minimum safe working load of 3,750 lbs. The vertical leg of the bracket shall extend to the point that the heel bears on the girder bottom flange, no closer than 4 inches from the bottom of the member. However, for 72-inch members, the heel of the bracket shall bear on the web, near the bottom flange transition.

Provide adequate overhang falsework and determine the appropriate adjustments for deck geometry, equipment, casting procedures and casting conditions.

Project R-5799

ST-4

Transylvania County

If the optional overhang falsework spacing is used, indicate this on the falsework submittal and advise the girder producer of the proposed details. Failure to notify the Engineer of hanger type and hanger spacing on prestressed concrete girder casting drawings may delay the approval of those drawings.

Falsework hangers that support concentrated loads and are installed at the edge of thin top flange concrete girders (such as bulb tee girders) shall be spaced so as not to exceed 75% of the manufacturer's stated safe working load. Use of dual leg hangers (such as Meadow Burke HF-42 and HF-43) are not allowed on concrete girders with thin top flanges. Design the falsework and forms supporting deck slabs and overhangs on girder bridges so that there will be no differential settlement between the girders and the deck forms during placement of deck concrete.

When staged construction of the bridge deck is required, detail falsework and forms for screed and fluid concrete loads to be independent of any previous deck pour components when the mid-span girder deflection due to deck weight is greater than $\frac{3}{4}$ ".

Note on the working drawings any anchorages, connectors, inserts, steel sleeves or other such devices used as part of the falsework or formwork that remains in the permanent structure. If the plan notes indicate that the structure contains the necessary corrosion protection required for a Corrosive Site, epoxy coat, galvanize or metalize these devices. Electroplating will not be allowed. Any coating required by the Engineer will be considered incidental to the various pay items requiring temporary works.

Design falsework and formwork requiring submittals in accordance with the 1995 AASHTO *Guide Design Specifications for Bridge Temporary Works* except as noted herein.

1. Wind Loads

Table 2.2 of Article 2.2.5.1 is modified to include wind velocities up to 110 mph. In addition, Table 2.2A is included to provide the maximum wind speeds by county in North Carolina.

Table 2.2 - Wind Pressure Values

Height Zone feet above ground	Pressure, lb/ft ² for Indicated Wind Velocity, mph				
	70	80	90	100	110
0 to 30	15	20	25	30	35
30 to 50	20	25	30	35	40
50 to 100	25	30	35	40	45
over 100	30	35	40	45	50

2. Time of Removal

The following requirements replace those of Article 3.4.8.2.

Do not remove forms until the concrete has attained strengths required in Article 420-16 of the Standard Specifications and these Special Provisions.

Do not remove forms until the concrete has sufficient strength to prevent damage to the surface.

Project R-5799

ST-6

Transylvania County

Table 2.2A - Steady State Maximum Wind Speeds by Counties in North Carolina

COUNTY	25 YR (mph)	COUNTY	25 YR (mph)	COUNTY	25 YR (mph)
Alamance	70	Franklin	70	Pamlico	100
Alexander	70	Gaston	70	Pasquotank	100
Alleghany	70	Gates	90	Pender	100
Anson	70	Graham	80	Perquimans	100
Ashe	70	Granville	70	Person	70
Avery	70	Greene	80	Pitt	90
Beaufort	100	Guilford	70	Polk	80
Bertie	90	Halifax	80	Randolph	70
Bladen	90	Harnett	70	Richmond	70
Brunswick	100	Haywood	80	Robeson	80
Buncombe	80	Henderson	80	Rockingham	70
Burke	70	Hertford	90	Rowan	70
Cabarrus	70	Hoke	70	Rutherford	70
Caldwell	70	Hyde	110	Sampson	90
Camden	100	Iredell	70	Scotland	70
Carteret	110	Jackson	80	Stanley	70
Caswell	70	Johnston	80	Stokes	70
Catawba	70	Jones	100	Surry	70
Cherokee	80	Lee	70	Swain	80
Chatham	70	Lenoir	90	Transylvania	80
Chowan	90	Lincoln	70	Tyrell	100
Clay	80	Macon	80	Union	70
Cleveland	70	Madison	80	Vance	70
Columbus	90	Martin	90	Wake	70
Craven	100	McDowell	70	Warren	70
Cumberland	80	Mecklenburg	70	Washington	100
Currituck	100	Mitchell	70	Watauga	70
Dare	110	Montgomery	70	Wayne	80
Davidson	70	Moore	70	Wilkes	70
Davie	70	Nash	80	Wilson	80
Duplin	90	New Hanover	100	Yadkin	70
Durham	70	Northampton	80	Yancey	70
Edgecombe	80	Onslow	100		
Forsyth	70	Orange	70		

Project R-5799

ST-7

Transylvania County

B. Review and Approval

The Engineer is responsible for the review and approval of temporary works' drawings.

Submit the working drawings sufficiently in advance of proposed use to allow for their review, revision (if needed), and approval without delay to the work.

The time period for review of the working drawings does not begin until complete drawings and design calculations, when required, are received by the Engineer.

Do not start construction of any temporary work for which working drawings are required until the drawings have been approved. Such approval does not relieve the Contractor of the responsibility for the accuracy and adequacy of the working drawings.

4.0 CONSTRUCTION REQUIREMENTS

All requirements of Section 420 of the Standard Specifications apply.

Construct temporary works in conformance with the approved working drawings. Ensure that the quality of materials and workmanship employed is consistent with that assumed in the design of the temporary works. Do not weld falsework members to any portion of the permanent structure unless approved. Show any welding to the permanent structure on the approved construction drawings.

Provide tell-tales attached to the forms and extending to the ground, or other means, for accurate measurement of falsework settlement. Make sure that the anticipated compressive settlement and/or deflection of falsework does not exceed 1 inch. For cast-in-place concrete structures, make sure that the calculated deflection of falsework flexural members does not exceed 1/240 of their span regardless of whether or not the deflection is compensated by camber strips.

A. Maintenance and Inspection

Inspect and maintain the temporary work in an acceptable condition throughout the period of its use. Certify that the manufactured devices have been maintained in a condition to allow them to safely carry their rated loads. Clearly mark each piece so that its capacity can be readily determined at the job site.

Perform an in-depth inspection of an applicable portion(s) of the temporary works, in the presence of the Engineer, not more than 24 hours prior to the beginning of each concrete placement. Inspect other temporary works at least once a month to ensure that they are functioning properly. Have a North Carolina Registered Professional Engineer inspect the cofferdams, shoring, sheathing, support of excavation structures, and support systems for load tests prior to loading.

B. Foundations

Determine the safe bearing capacity of the foundation material on which the supports for temporary works rest. If required by the Engineer, conduct load tests to verify proposed bearing capacity values that are marginal or in other high-risk situations.

The use of the foundation support values shown on the contract plans of the permanent structure is permitted if the foundations are on the same level and on the same soil as those of the permanent structure.

Allow for adequate site drainage or soil protection to prevent soil saturation and washout of the soil supporting the temporary works supports.

If piles are used, the estimation of capacities and later confirmation during construction using standard procedures based on the driving characteristics of the pile is permitted. If preferred, use load tests to confirm the estimated capacities; or, if required by the Engineer conduct load tests to verify bearing capacity values that are marginal or in other high risk situations.

The Engineer reviews and approves the proposed pile and soil bearing capacities.

5.0 REMOVAL

Unless otherwise permitted, remove and keep all temporary works upon completion of the work. Do not disturb or otherwise damage the finished work.

Remove temporary works in conformance with the contract documents. Remove them in such a manner as to permit the structure to uniformly and gradually take the stresses due to its own weight.

6.0 METHOD OF MEASUREMENT

Unless otherwise specified, temporary works will not be directly measured.

7.0 BASIS OF PAYMENT

Payment at the contract unit prices for the various pay items requiring temporary works will be full compensation for the above falsework and formwork.

Project R-5799

ST-9

Transylvania County

SUBMITTAL OF WORKING DRAWINGS**(2-14-22)****8.0 GENERAL**

Submit working drawings in accordance with Article 105-2 of the *Standard Specifications* and this provision. For this provision, “submittals” refers to only those listed in this provision. The list of submittals contained herein does not represent a list of required submittals for the project. Submittals are only necessary for those items as required by the contract. Make submittals that are not specifically noted in this provision directly to the Engineer. Either the Structures Management Unit or the Geotechnical Engineering Unit or both units will jointly review submittals.

If a submittal contains variations from plan details or specifications or significantly affects project cost, field construction or operations, discuss the submittal with and submit all copies to the Engineer. State the reason for the proposed variation in the submittal. To minimize review time, make sure all submittals are complete when initially submitted. Provide a contact name and information with each submittal. Direct any questions regarding submittal requirements to the Engineer, Structures Management Unit contacts or the Geotechnical Engineering Unit contacts noted below.

To facilitate in-plant inspection by NCDOT and approval of working drawings, provide the name, address and telephone number of the facility where fabrication will actually be done if different than shown on the title block of the submitted working drawings. This includes, but is not limited to, precast concrete items, prestressed concrete items and fabricated steel or aluminum items.

9.0 ADDRESSES AND CONTACTS

For submittals to the Structures Management Unit, use the following addresses:

Via Email: SMU-wdr@ncdot.gov (do not cc SMU Working Drawings staff)

Via US mail:

Mr. B. C. Hanks, P. E.
State Structures Engineer
North Carolina Department
of Transportation
Structures Management Unit
1581 Mail Service Center
Raleigh, NC 27699-1581

Attention: Mr. J. L. Bolden, P. E.

Via other delivery service:

Mr. B. C. Hanks, P. E.
State Structures Engineer
North Carolina Department
of Transportation
Structures Management Unit
1000 Birch Ridge Drive
Raleigh, NC 27610

Attention: Mr. J. L. Bolden, P. E.

For submittals to the Geotechnical Engineering Unit, use the following addresses:

For projects in Divisions 1-7, use the following Eastern Regional Office addresses:

Project R-5799

ST-10

Transylvania County

Via Email: EastGeotechnicalSubmittal@ncdot.gov

Via US mail:

Mr. David Hering, L.G., P. E.
Assistant State Geotechnical
Engineer – Eastern Region
North Carolina Department
of Transportation
Geotechnical Engineering Unit
Eastern Regional Office
1570 Mail Service Center
Raleigh, NC 27699-1570

Via other delivery service:

Mr. David Hering, L.G., P. E.
Assistant State Geotechnical
Engineer – Eastern Region
North Carolina Department
of Transportation
Geotechnical Engineering Unit
Eastern Regional Office
3301 Jones Sausage Road, Suite 100
Garner, NC 27529

For projects in Divisions 8-14, use the following Western Regional Office addresses:

Via Email: WestGeotechnicalSubmittal@ncdot.gov

Via US mail or other delivery service:

Mr. Eric Williams, P. E.
Assistant State Geotechnical
Engineer – Western Region
North Carolina Department
of Transportation
Geotechnical Engineering Unit
Western Regional Office
5253 Z Max Boulevard
Harrisburg, NC 28075

The status of the review of structure-related submittals sent to the Structures Management Unit can be viewed from the Unit's website, via the "[Drawing Submittal Status](#)" link.

The status of the review of geotechnical-related submittals sent to the Geotechnical Engineering Unit can be viewed from the Unit's website, via the "[Geotechnical Construction Submittals](#)" link.

Direct any questions concerning submittal review status, review comments or drawing markups to the following contacts:

Primary Structures Contact:

James Bolden (919) 707 – 6408
jlbolden@ncdot.gov

Secondary Structures Contacts:

Emmanuel Omile (919) 707 – 6451
eomile@ncdot.gov

Project R-5799

ST-11

Transylvania County

Madonna Rorie (919) 707 – 6508
mrorie@ncdot.gov

Eastern Regional Geotechnical Contact (Divisions 1-7):

David Hering (919) 662 – 4710
dthering@ncdot.gov

Western Regional Geotechnical Contact (Divisions 8-14):

Eric Williams (704) 455 – 8902
ewilliams3@ncdot.gov

10.0 SUBMITTAL COPIES

Furnish one complete copy of each submittal, including all attachments, to the Engineer. At the same time, submit a copy of the same complete submittal directly to the Structures Management Unit and/or the Geotechnical Engineering Unit as specified in the tables below.

The first table below covers “Structure Submittals.” The Engineer will receive review comments and drawing markups for these submittals from the Structures Management Unit. The second table in this section covers “Geotechnical Submittals.” The Engineer will receive review comments and drawing markups for these submittals from the Geotechnical Engineering Unit.

Unless otherwise required, submit one set of supporting calculations to either the Structures Management Unit or the Geotechnical Engineering Unit unless both units require submittal copies in which case submit a set of supporting calculations to each unit. Provide additional copies of any submittal as directed.

STRUCTURE SUBMITTALS

Submittal	Submittal Required by Structures Management Unit?	Submittal Required by Geotechnical Engineering Unit?	Contract Reference Requiring Submittal ¹
Arch Culvert Falsework	Y	N	Plan Note, SN Sheet & “Falsework and Formwork”
Box Culvert Falsework ⁷	Y	N	Plan Note, SN Sheet & “Falsework and Formwork”
Cofferdams	Y	Y	Article 410-4
Foam Joint Seals ⁶	Y	N	“Foam Joint Seals”

Project R-5799

ST-12

Transylvania County

Expansion Joint Seals (hold down plate type with base angle)	Y	N	“Expansion Joint Seals”
Expansion Joint Seals (modular)	Y	N	“Modular Expansion Joint Seals”
Expansion Joint Seals (strip seals)	Y	N	“Strip Seal Expansion Joints”
Falsework & Forms ² (substructure)	Y	N	Article 420-3 & “Falsework and Formwork”
Falsework & Forms (superstructure)	Y	N	Article 420-3 & “Falsework and Formwork”
Girder Erection over Railroad	Y	N	Railroad Provisions
Maintenance and Protection of Traffic Beneath Proposed Structure	Y	N	“Maintenance and Protection of Traffic Beneath Proposed Structure at Station ____”
Metal Bridge Railing	Y	N	Plan Note
Metal Stay-in-Place Forms	Y	N	Article 420-3
Metalwork for Elastomeric Bearings ^{4,5}	Y	N	Article 1072-8
Miscellaneous Metalwork ^{4,5}	Y	N	Article 1072-8
Disc Bearings ⁴	Y	N	“Disc Bearings”
Overhead and Digital Message Signs (DMS) (metalwork and foundations)	Y	N	Applicable Provisions
Placement of Equipment on Structures (cranes, etc.)	Y	N	Article 420-20
Prestressed Concrete Box Beam (detensioning sequences) ³	Y	N	Article 1078-11
Precast Concrete Box Culverts	Y	N	“Optional Precast Reinforced Concrete Box Culvert at Station ____”
Prestressed Concrete Cored Slab (detensioning sequences) ³	Y	N	Article 1078-11
Prestressed Concrete Deck Panels	Y	N	Article 420-3

Project R-5799

ST-13

Transylvania County

Prestressed Concrete Girder (strand elongation and detensioning sequences)	Y	N	Articles 1078-8 and 1078- 11
Removal of Existing Structure over Railroad	Y	N	Railroad Provisions
Revised Bridge Deck Plans (adaptation to prestressed deck panels)	Y	N	Article 420-3
Revised Bridge Deck Plans (adaptation to modular expansion joint seals)	Y	N	“Modular Expansion Joint Seals”
Sound Barrier Wall (precast items)	Y	N	Article 1077-2 & “Sound Barrier Wall”
Sound Barrier Wall Steel Fabrication Plans ⁵	Y	N	Article 1072-8 & “Sound Barrier Wall”
Structural Steel ⁴	Y	N	Article 1072-8
Temporary Detour Structures	Y	Y	Article 400-3 & “Construction, Maintenance and Removal of Temporary Structure at Station _____”
TFE Expansion Bearings ⁴	Y	N	Article 1072-8

FOOTNOTES

- References are provided to help locate the part of the contract where the submittals are required. References in quotes refer to the provision by that name. Articles refer to the *Standard Specifications*.
- Submittals for these items are necessary only when required by a note on plans.
- Submittals for these items may not be required. A list of pre-approved sequences is available from the producer or the Materials & Tests Unit.
- The fabricator may submit these items directly to the Structures Management Unit.
- The two sets of preliminary submittals required by Article 1072-8 of the *Standard Specifications* are not required for these items.
- Submittals for Fabrication Drawings are not required. Submittals for Catalogue Cuts of Proposed Material are required. See Section 5.A of the referenced provision.

Project R-5799

ST-14

Transylvania County

7. Submittals are necessary only when the top slab thickness is 18" or greater.

GEOTECHNICAL SUBMITTALS

Submittal	Submittals Required by Geotechnical Engineering Unit	Submittals Required by Structures Management Unit	Contract Reference Requiring Submittal ¹
Drilled Pier Construction Plans ²	Y	N	Subarticle 411-3(A)
Crosshole Sonic Logging (CSL) Reports ²	Y	N	Subarticle 411-5(A)(2)
Pile Driving Equipment Data Forms ^{2,3}	Y	N	Subarticle 450-3(D)(2)
Pile Driving Analyzer (PDA) Reports ²	Y	N	Subarticle 450-3(F)(3)
Retaining Walls ⁴	Y; drawings and calculations	Y; drawings	Applicable Provisions
Temporary Shoring ⁴	Y; drawings and calculations	Y; drawings	“Temporary Shoring” & “Temporary Soil Nail Walls”

FOOTNOTES

- References are provided to help locate the part of the contract where the submittals are required. References in quotes refer to the provision by that name. Subarticles refer to the *Standard Specifications*.
- Submit one hard copy of submittal to the Engineer. Submit a second copy of submittal electronically (PDF via email), US mail or other delivery service to the appropriate Geotechnical Engineering Unit regional office. Electronic submission is preferred.
- The Pile Driving Equipment Data Form is available from:
https://connect.ncdot.gov/resources/Geological/Pages/Geotech_Forms_Details.aspx
See second page of form for submittal instructions.
- Electronic copy of submittal is required. See referenced provision.

Project R-5799

ST-15

Transylvania County

CRANE SAFETY**(6-20-19)**

Comply with the manufacturer specifications and limitations applicable to the operation of any and all cranes and derricks. Prime contractors, sub-contractors, and fully operated rental companies shall comply with the current Occupational Safety and Health Administration (OSHA) regulations.

Submit all items listed below to the Engineer prior to beginning crane operations. Changes in personnel or equipment must be reported to the Engineer and all applicable items listed below must be updated and submitted prior to continuing with crane operations.

CRANE SAFETY SUBMITTAL LIST

- A. **Competent Person:** Provide the name and qualifications of the “Competent Person” responsible for crane safety and lifting operations. The named competent person will have the responsibility and authority to stop any work activity due to safety concerns.
- B. **Riggers:** Provide the qualifications and experience of the persons responsible for rigging operations. Qualifications and experience should include, but not be limited to, weight calculations, center of gravity determinations, selection and inspection of sling and rigging equipment, and safe rigging practices.
- C. **Crane Inspections:** Inspection records for all cranes shall be current and readily accessible for review upon request.
- D. **Certifications:** Crane operators shall be certified by the National Commission for the Certification of Crane Operators (NCCCO) or the National Center for Construction Education and Research (NCCER). Other approved nationally accredited programs will be considered upon request. In addition, crane operators shall have a current CDL medical card. Submit a list of crane operator(s) and include current certification for each type of crane operated (small hydraulic, large hydraulic, small lattice, large lattice) and medical evaluations for each operator.

Project R-5799

ST-16

Transylvania County

GROUT FOR STRUCTURES**(12-1-17)****1.0 DESCRIPTION**

This special provision addresses grout for use in pile blockouts, grout pockets, shear keys, dowel holes and recesses for structures. This provision does not apply to grout placed in post-tensioning ducts for bridge beams, girders, decks, end bent caps, or bent caps. Mix and place grout in accordance with the manufacturer's recommendations, the applicable sections of the Standard Specifications and this provision.

2.0 MATERIAL REQUIREMENTS

Unless otherwise noted on the plans, use a Type 3 Grout in accordance with Section 1003 of the Standard Specifications.

Initial setting time shall not be less than 10 minutes when tested in accordance with ASTM C266.

Construction loading and traffic loading shall not be allowed until the 3 day compressive strength is achieved.

3.0 SAMPLING AND PLACEMENT

Place and maintain components in final position until grout placement is complete and accepted. Concrete surfaces to receive grout shall be free of defective concrete, laitance, oil, grease and other foreign matter. Saturate concrete surfaces with clean water and remove excess water prior to placing grout.

4.0 BASIS OF PAYMENT

No separate payment will be made for "Grout for Structures". The cost of the material, equipment, labor, placement, and any incidentals necessary to complete the work shall be considered incidental to the structure item requiring grout.

PROJECT SPECIAL PROVISION

(10-18-95) (Rev. 8-15-23)

Z-1a

PERMITS

The Contractor's attention is directed to the following permits, which have been issued to the Department of Transportation by the authority granting the permit.

<u>PERMIT</u>	<u>AUTHORITY GRANTING THE PERMIT</u>
Dredge and Fill and/or Work in Navigable Waters (404)	U. S. Army Corps of Engineers
Water Quality (401)	Division of Environmental Management, DEQ State of North Carolina

The Contractor shall comply with all applicable permit conditions during construction of this project.

Agents of the permitting authority will periodically inspect the project for adherence to the permits.

The Contractor's attention is also directed to Articles 107-10 and 107-13 of the *2018 Standard Specifications* and the following:

Should the Contractor propose to utilize construction methods (such as temporary structures or fill in waters and/or wetlands for haul roads, work platforms, cofferdams, etc.) not specifically identified in the permit (individual, general, or nationwide) authorizing the project it shall be the Contractor's responsibility to coordinate with the Engineer to determine what, if any, additional permit action is required. The Contractor shall also be responsible for initiating the request for the authorization of such construction method by the permitting agency. The request shall be submitted through the Engineer. The Contractor shall not utilize the construction method until it is approved by the permitting agency. The request normally takes approximately 60 days to process; however, no extensions of time or additional compensation will be granted for delays resulting from the Contractor's request for approval of construction methods not specifically identified in the permit.

Where construction moratoriums are contained in a permit condition which restricts the Contractor's activities to certain times of the year, those moratoriums will apply only to the portions of the work taking place in the restricted waters, wetlands or buffer zones, provided that activities outside those areas is done in such a manner as to not affect the restricted waters, wetlands or buffer zones.

**U.S. ARMY CORPS OF ENGINEERS
WILMINGTON DISTRICT**

Action Id. **SAW-2022-02043** County: **Transylvania County** U.S.G.S. Quad: **Pisgah Forest**

GENERAL PERMIT (REGIONAL AND NATIONWIDE) VERIFICATION

Permittee: **North Carolina Department of Transportation**

Mr. Kevin Barnett

Address: **253 Webster Road**

Sylva NC, 28779

Nearest Town **Pisgah Forest**

Nearest Waterway **Davidson River**

USGS HUC **06010105**

River Basin **French Broad-Holston**

Coordinates Latitude: **35.272801;**

Longitude: **-82.705099**

Location description: **The R5799 project is located along US 64, Hwy 276 and Hwy 280 where they intersect at a four way intersection in Pisgah Forest, Transylvania County, North Carolina.**

Description of projects area and activity: **This permit verification authorizes construction of two traffic circles (one at the entrance to Pisgah National Forest and one at Ecusta Rd.) and will result in the permanent impact to 371 lf of stream channel and 0.01 acres of wetland impact.**

Applicable Law: Section 404 (Clean Water Act, 33 USC 1344);
 Section 10 (Rivers and Harbors Act, 33 USC 403)

Authorization: Regional General Permit Number and/or Nationwide Permit Number: **GP 50 - NCDOT - Bridge, Road Widening and Interchanges**

SEE ATTACHED RGP or NWP GENERAL, REGIONAL AND/OR SPECIAL CONDITIONS

Special Conditions

- 1) **Endangered Species: In order to avoid and minimize effects to endangered species DOT will comply with the following measure.**
 - a. **NCDOT will remove trees between October 15 and April 1, outside the bat active season.**
 - b. **NCDOT will comply with Best Management Practices as outlined in the Standards Manual for sensitive waters.**
 - c. **NCDOT will conduct bat roost surveys on all culverts and bridges that will be widened, extended, or otherwise impacted by the project within two years of the start of construction. NCDOT will notify the U.S. Fish and Wildlife Service (Service) if bats are discovered.**
 - d. **NCDOT or other parties will not install new permanent lighting as part of the project or as a consequence of the proposed action.**
 - e. **NCDOT will ensure temporary lighting for night work is shielded and faces away from waterways and riparian areas.**
- 2) **In order to compensate for impacts associated with this permit, mitigation shall be provided in accordance with the provisions outlined on the most recent version of the**

attached Compensatory Mitigation Responsibility Transfer Form. The requirements of this form, including any special conditions listed on this form, are hereby incorporated as special conditions of this permit authorization.

Your work is authorized by the above referenced permit provided it is accomplished in strict accordance with the attached conditions and your submitted application dated September 1, 2022 and the ensuing record. Any violation of the attached conditions or deviation from your submitted plans may subject the permittee to a stop work order, a restoration order, a Class I administrative penalty, and/or appropriate legal action.

This verification will remain valid until the expiration date identified below unless the nationwide and/or regional general permit authorization is modified, suspended or revoked. If, prior to the expiration date identified below, the nationwide and/or regional general permit authorization is reissued and/or modified, this verification will remain valid until the expiration date identified below, provided it complies with all requirements of the modified nationwide permit. If the nationwide and/or regional general permit authorization expires or is suspended, revoked, or is modified, such that the activity would no longer comply with the terms and conditions of the nationwide permit, activities which have commenced (i.e., are under construction) or are under contract to commence in reliance upon the nationwide and/or regional general permit, will remain authorized provided the activity is completed within twelve months of the date of the nationwide and/or regional general permit's expiration, modification or revocation, unless discretionary authority has been exercised on a case-by-case basis to modify, suspend or revoke the authorization.

Activities subject to Section 404 (as indicated above) may also require an individual Section 401 Water Quality Certification. You should contact the NC Division of Water Resources (telephone 919-807-6300) to determine Section 401 requirements.

For activities occurring within the twenty coastal counties subject to regulation under the Coastal Area Management Act (CAMA), prior to beginning work you must contact the N.C. Division of Coastal Management in Morehead City, NC, at (252) 808-2808.

This Department of the Army verification does not relieve the permittee of the responsibility to obtain any other required Federal, State or local approvals/permits.

If there are any questions regarding this verification, any of the conditions of the Permit, or the Corps of Engineers regulatory program, please contact **Crystal Amschler at (828) 271-7980 X 4231 or Crystal.C.Amschler@usace.army.mil.**

Corps Regulatory Official: *Mark Matthewz* 2023.05.08 07:06:05
Expiration Date of Verification: **May 25, 2025** Date: **May 8, 2023**

The Wilmington District is committed to providing the highest level of support to the public. To help us ensure we continue to do so, please complete our Customer Satisfaction Survey, located online at <https://regulatory.ops.usace.army.mil/customer-service-survey/>

Action ID Number: SAW-2022-02043

County: Transylvania County

Permittee: North Carolina Department of Transportation

Project Name: NCDOT / US 64, US 276, and NC 280 / R-5799 / Transylvania County / Div 14

Date Verification Issued: May 8, 2023

Project Manager: Crystal Amschler

Upon completion of the activity authorized by this permit and any mitigation required by the permit, sign this certification and return it to the following address:

**US ARMY CORPS OF ENGINEERS
WILMINGTON DISTRICT**

Attn: Crystal Amschler, Project Manager
WRDA-Transportation Permitting Branch
151 Patton Avenue, Room 208
Asheville, North Carolina 28801

Please note that your permitted activity is subject to a compliance inspection by a U. S. Army Corps of Engineers representative. Failure to comply with any terms or conditions of this authorization may result in the Corps suspending, modifying or revoking the authorization and/or issuing a Class I administrative penalty, or initiating other appropriate legal action.

I hereby certify that the work authorized by the above referenced permit has been completed in accordance with the terms and condition of the said permit, and required mitigation was completed in accordance with the permit conditions.

Signature of Permittee

Date

P-5

DEPARTMENT OF THE ARMY
Wilmington District, Corps of Engineers
69 Darlington Avenue
Wilmington, North Carolina 28403-1343

Regional General Permit No. SAW-2019-02350 (RGP 50)
Name of Permittee: North Carolina Department of Transportation
Effective Date: May 26, 2020
Expiration Date: May 25, 2025

DEPARTMENT OF THE ARMY REGIONAL GENERAL PERMIT

A regional general permit (RGP) to perform work in or affecting navigable waters of the United States and waters of the United States, upon recommendation of the Chief of Engineers, pursuant to Section 10 of the Rivers and Harbors Act of March 3, 1899 (33 U.S.C. 403), and Section 404 of the Clean Water Act (33 U.S.C. 1344), is hereby issued by authority of the Secretary of the Army by the

District Commander
U.S. Army Engineer District, Wilmington
Corps of Engineers
69 Darlington Avenue
Wilmington, North Carolina 28403-1343

TO AUTHORIZE THE DISCHARGE OF DREDGED OR FILL MATERIAL IN WATERS OF THE UNITED STATES (U.S.), INCLUDING WETLANDS, ASSOCIATED WITH MAINTENANCE, REPAIR, AND CONSTRUCTION PROJECTS CONDUCTED BY THE VARIOUS DIVISIONS OF THE NORTH CAROLINA DEPARTMENT OF TRANSPORTATION (NCDOT), INCLUDING THE NCDOT DIVISION OF HIGHWAYS, RAIL, BICYCLE/PEDESTRIAN, ETC.

Activities authorized by this RGP:

- a. (1) Road widening, and/or (2) construction, maintenance, and/or repair of bridges. For bridge projects, work can include the approaches.
- b. (1) Improvement of interchanges or intersections, or (2) construction of interchanges or intersections over, or on, existing roads.

Full descriptions/terms of “a” and “b”:

a. (1) Road widening, and/or (2) construction, maintenance, and/or repair of bridges. For bridge projects, work can include the approaches.

Permanent impacts that result in a loss of waters of the U.S., excluding stream relocation(s), must be less than or equal to 500 linear feet (lf) of stream and/or one (1) acre of wetland/open water for each single and complete linear project.

Single and complete linear project. As noted in 33 CFR 330.2(i), for linear projects, the “single and complete project” (i.e., single and complete crossing) will apply to each crossing of a separate water of the U.S. (i.e., single waterbody) at that location; except that for linear projects crossing a single waterbody several times at separate and distant locations, each crossing is considered a single and complete project. However, individual channels in a braided stream or river, or individual arms of a large, irregularly-shaped wetland or lake, etc., are not separate waterbodies and crossing of such features cannot be considered separately.

Also authorized under “a”: (1) stream relocation(s) and (2) temporary impacts, such as those from temporary structures, fills, dewatering, and other work necessary to conduct the activities listed under “a”. Stream relocation(s) and temporary impacts will be evaluated independently and are not limited to the permanent loss limits of 500 lf of stream and/or 1 acre of wetland/open water (i.e., stream relocations and/or temporary impacts do not factor into these limits) for each single and complete linear project; however, if the Corps determines that the proposed stream relocation(s) and/or temporary impacts are of such magnitude that they cannot be authorized under this section (“a”) of RGP 50, even if the permanent losses from road widening, and/or construction, maintenance, and repair of bridges do not exceed the impact limits for this section (“a”) of RGP 50, an Individual Permit will be required.

If the Corps determines, on a case-by-case basis, that the concerns for the aquatic environment so indicate, he/she may exercise discretionary authority to override this RGP and require an Individual Permit.

b. (1) Improvement of interchanges or intersections, or (2) construction of interchanges or intersections, over or, on existing roads.

For activities authorized under “b”, the limits for permanent impacts that result in a loss of waters of the U.S. depend on the location of the impacts, as described below:

- In the coastal plain of North Carolina (both inner coastal plain and outer coastal plain) - permanent impacts that result in a loss of waters of the U.S., excluding stream relocation(s), must be less than or equal to 1,000 lf of stream and/or 3 acres of wetland/open water for the entire interchange or intersection project.

- All other areas of North Carolina - permanent impacts that result in a loss of waters of the U.S., excluding stream relocation(s), must be less than or equal to 1,000 lf of stream and/or 2 acres of wetland/open water for the entire interchange or intersection project.

Coastal plain – See http://saw-reg.usace.army.mil/JD/LRRs_PandT.pdf for Land Resource Areas LRRP (inner coastal plain) and LRRT (outer coastal plain).

When proposed impacts to waters of the U.S. are located both inside AND outside of the coastal plain, the Corps will determine, based on the location(s) of proposed impacts to waters of the U.S., if a project is a “coastal plain project”.

Single and complete project. For permitting purposes, each interchange or intersection is considered to be one single and complete project. For example, an interchange project cannot result in a permanent loss (excluding stream relocation), of (1) greater than 1,000 lf of stream and/or 3 acres of wetland/open water in the coastal plain OR (2) greater than 1,000 lf of stream and/or 2 acres of wetland/open water in all other areas of North Carolina.

Approach fills may be considered to be part of an interchange or intersection project if the Corps determines that inclusion of these areas meet the terms of this section (“b”) of RGP 50. Early coordination with the Corps is encouraged.

Intersections, regardless of the mode of transportation (e.g., railroad, other roadways, etc.), may be at grade or grade separated if the Corps determines that the project would meet the terms of this section (“b”) of RGP 50. Early coordination with the Corps is encouraged.

Also authorized under “b”: (1) stream relocation(s) and (2) temporary impacts, such as those from temporary structures, fills, dewatering, and other work necessary to conduct the activities listed under “b”. Stream relocation(s) and temporary impacts will be evaluated independently and are not limited to the permanent loss limits of (1) 1,000 lf of stream and/or 3 acres of wetland/open water in the coastal plain OR (2) 1,000 lf of stream and/or 2 acres of wetland/open water in all other areas of North Carolina (i.e., stream relocations and/or temporary impacts do not factor into these limits) for each interchange or intersection project; however, if the Corps determines that the proposed stream relocation(s) and/or temporary impacts are of such magnitude that they cannot be authorized under this section (“b”) of RGP 50, even if the permanent losses from improvement of interchanges or intersections, or construction of interchanges or intersections over, or on, existing roads do not exceed the impact limits for this section (“b”) of RGP 50, an Individual Permit will be required.

If the Corps determines, on a case-by-case basis, that the concerns for the aquatic environment so indicate, he/she may exercise discretionary authority to override this RGP and require an Individual Permit.

1. Special Conditions.

a. The prospective permittee must submit a pre-construction notification (PCN) and applicable supporting information to the District Engineer and receive written verification from the Corps that the proposed work complies with this RGP prior to commencing any activity authorized by this RGP.

b. If the project will not impact a designated “Area of Environmental Concern” (AEC) in the twenty* (20) counties of North Carolina covered by the North Carolina Coastal Area Management Act (CAMA) (“CAMA counties”), a consistency submission is not required. If the project will impact a designated AEC and meets the definition of “development”, the prospective permittee must obtain the required CAMA permit. Development activities shall not commence until a copy of the approved CAMA permit is furnished to the appropriate Corps Regulatory Field Office (Wilmington Field Office – 69 Darlington Avenue, Wilmington, NC 28403 or Washington Field Office – 2407 West 5th Street, Washington, NC 27889).

***The 20 CAMA counties in North Carolina include Beaufort, Bertie, Brunswick, Camden, Carteret, Chowan, Craven, Currituck, Dare, Gates, Hertford, Hyde, New Hanover, Onslow, Pamlico, Pasquotank, Pender, Perquimans, Tyrrell, and Washington.**

c. No work shall be authorized by this RGP within the 20* CAMA counties without prior consultation with the National Oceanic and Atmospheric Administration’s (NOAA) Habitat Conservation Division. For each activity reviewed by the Corps where it is determined that the activity may affect Essential Fish Habitat (EFH) for federally managed species, an EFH Assessment shall be prepared by the prospective permittee and forwarded to the Corps and NOAA Fisheries for review and comment prior to authorization of work.

d. Culverts and pipes. The following conditions [(1)-(8)] apply to the construction of culverts/pipes, and work on existing culverts/pipes.

Additionally, if the proposed work would affect an existing culvert/pipe (e.g., culvert/pipe extensions), the prospective permittee must include actions (in the PCN) to correct any existing deficiencies that are located:

- At the inlet and/or outlet of the existing culvert/pipe, IF these deficiencies are/were caused by the existing culvert/pipe, or
- Near the inlet or outlet of the existing culvert/pipe, IF these deficiencies are/were caused by the existing culvert/pipe.

P-9

These deficiencies may include, but are not limited to, stream over-widening, bank erosion, streambed scour, perched culvert/pipes, and inadequate water depth in culvert(s). Also note if the proposed work would address the existing deficiency or eliminate it – e.g., bank erosion on left bank, but the culvert extension will be placed in this eroded area. If the prospective permittee is unable to correct the deficiencies caused by the existing culvert/pipe, they must document the reasons in the PCN for Corps consideration.

(1) No activity may result in substantial, permanent disruption of the movement of those species of aquatic life indigenous to the waterbody, including those species that normally migrate through the area. Measures will be included that will promote the safe passage of fish and other aquatic organisms.

(2) The dimension, pattern, and profile of the stream above and below a culvert/pipe shall not be modified by widening the stream channel or by reducing the depth of the stream in connection with the construction activity. It is acceptable to use rock vanes at culvert/pipe outlets to ensure, enhance, or maintain aquatic passage. Pre-formed scour holes are acceptable when designed for velocity reduction. The width, height, and gradient of a proposed opening shall be such as to pass the average historical low flow and spring flow without adversely altering flow velocity. Spring flow will be determined from gauge data, if available. In the absence of such data, bankfull flow will be used as a comparable level.

(3) Burial/depth specifications: If the project is located within any of the 20* CAMA counties, culvert/pipe inverts will be buried at least one foot below normal bed elevation when they are placed within the Public Trust AEC and/or the Estuarine Waters AEC as designated by CAMA. If the project is located outside of the 20* CAMA counties, culvert/pipe inverts will be buried at least one foot below the bed of the stream for culverts/pipes that are greater than 48 inches in diameter. Culverts/pipes that are 48 inches in diameter or less shall be buried or placed on the stream bed as practicable and appropriate to maintain aquatic passage, to include passage during drought or low flow conditions. Every effort shall be made to maintain the existing channel slope. A waiver from the burial/depth specifications in this condition may be requested in writing. The prospective permittee is encouraged to request agency input about waiver requests as early as possible, and prior to submitting the PCN for a specific project; this will allow the agencies time to conduct a site visit, if necessary, and will prevent time delays and potential project revisions for the prospective permittee. The waiver will only be issued by the Corps if it can be demonstrated that the impacts of complying with burial requirements would result in more adverse impacts to the aquatic environment.

(4) Appropriate actions to prevent destabilization of the channel and head cutting upstream shall be incorporated in the design and placement of culverts/pipes.

(5) Culverts/pipes placed within riparian and/or riverine wetlands must be installed in a manner that does not restrict the flow and circulation patterns of waters of the U.S. Culverts/pipes placed across wetland fills purely for the purposes of equalizing surface

P-10

water do not have to be buried, but must be of adequate size and/or number to ensure unrestricted transmission of water.

(6) Bankfull flows (or less) shall be accommodated through maintenance of the existing bankfull channel cross sectional area in no more than one culvert/pipe or culvert/pipe barrel. Additional culverts/pipes or barrels at such crossings shall be allowed only to receive flows exceeding the bankfull flow. A waiver from this condition may be requested in writing; this request must be specific as to the reason(s) for the request. The waiver will be issued if it can be demonstrated that it is not practicable to comply with this condition.

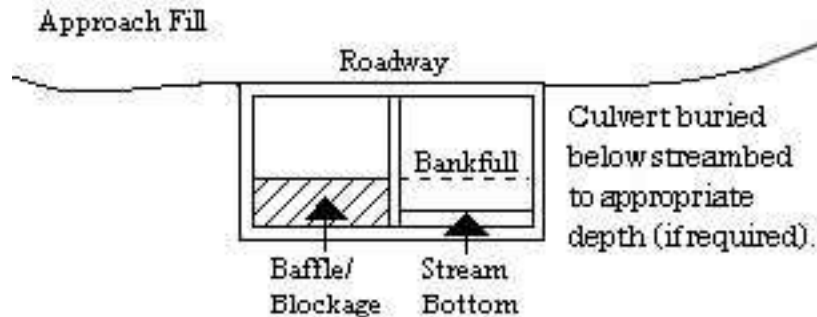

(7) Where adjacent floodplain is available, flows exceeding bankfull will be accommodated by installing culverts/pipes at the floodplain elevation. When multiple culverts/pipes are used, baseflow must be maintained at the appropriate width and depth by the construction of floodplain benches, sills, and/or construction methods to ensure that the overflow culvert(s)/pipe(s) is elevated above the baseflow culvert(s)/pipe(s).

(8) The width of the baseflow culvert/pipe shall be comparable to the width of the bankfull width of the stream channel. If the width of the baseflow culvert/pipe is wider than the stream channel, the culvert/pipe shall include baffles, benches and/or sills to maintain the width of the stream channel. A waiver from this condition may be requested in writing; this request must be specific as to the reason(s) for the request. The waiver will be issued if it can be demonstrated that it is not practicable or necessary to include baffles, benches or sills.

See the remaining special conditions for additional information about culverts/pipes in specific areas.

e. Discharges into waters of the U.S. designated by either the North Carolina Division of Marine Fisheries (NCDMF) or the North Carolina Wildlife Resources Commission (NCWRC) as anadromous fish spawning areas are prohibited during the period between February 15th and June 30th, without prior written approval from the Corps and the appropriate wildlife agencies (NCDMF, NCWRC, and/or the National Marine Fisheries Service (NMFS)). Discharges into waters of the U.S. designated by NCWRC as primary nursery areas in inland waters are prohibited during the period between February 15th and September 30th, without prior written approval from the Corps and the appropriate wildlife agencies. Discharges into waters of the U.S. designated by NCDMF as primary nursery areas shall be coordinated with NCDMF prior to being authorized by

this RGP. Coordination with NCDMF may result in a required construction moratorium during periods of significant biological productivity or critical life stages.

The prospective permittee should contact:

NC Division of Marine Fisheries
3441 Arendell Street
Morehead City, NC 28557
Telephone 252-726-7021
or 800-682-2632

North Carolina Wildlife Resources Commission
Habitat Conservation Division
1721 Mail Service Center
Raleigh, NC 27699-1721
Telephone (919) 707-0220

f. This permit does not authorize the use of culverts in areas designated as anadromous fish spawning areas by the NCDMF or the NCWRC.

g. No in-water work shall be conducted in Waters of the U.S. designated as Atlantic sturgeon critical habitat during the periods between February 1st and June 30th. No in-water work shall be conducted in Waters of the U.S. in the Roanoke River designated as Atlantic sturgeon critical habitat during the periods between February 1st and June 30th, and between August 1st to October 31st, without prior written approval from NMFS.

h. Before discharging dredged or fill material into waters of the U.S. in designated trout watersheds in North Carolina, the PCN will be sent to the NCWRC and the Corps concurrently. See <https://www.saw.usace.army.mil/Missions/Regulatory-Permit-Program/Agency-Coordination/Trout.aspx> for the designated trout watersheds. The PCN shall summarize alternatives to conducting work in waters of the U.S. in trout watersheds that were considered during the planning process and detail why alternatives were or were not selected. For proposals where (1) a bridge in a trout stream will be replaced with a culvert, or (2) a culvert will be placed in a trout stream, the PCN must also include a compensatory mitigation plan for all loss of stream bed, and details of any on-site evaluations that were conducted to determine that installation of a culvert will not adversely affect passage of fish or other aquatic biota at the project site. The evaluation information must include factors such as the proposed slope of the culvert and determinations of how the slope will be expected to allow or impede passage, the necessity of baffles and/or sills to ensure passage, design considerations to ensure that expected baseflow will be maintained for passage and that post-construction velocities will not prevent passage, site conditions that will or will not allow proper burial of the culvert, existing structures (e.g., perched culverts, waterfalls, etc.) and/or stream patterns up and downstream of the culvert site that could affect passage and bank stability, and any other considerations regarding passage. The level of detail for this information shall be based on site conditions (i.e., culverts on a slope over 3% will most likely require more information than culverts on a slope that is less than 1%, etc.). Also, in order to evaluate potential impacts, the prospective permittee will describe bedforms that will be impacted by the proposed culvert – e.g., pools, glides, riffles, etc. The NCWRC will respond to both the prospective permittee and the Corps.

P-12

i. For all activities authorized by this RGP that involve the use of riprap material for bank stabilization, the following measures shall be applied:

(1) Where bank stabilization is conducted as part of an activity, natural design, bioengineering, and/or geoengineering methods that incorporate natural durable materials, native seed mixes, and native plants and shrubs are to be utilized, as appropriate to site conditions, to the maximum extent practicable.

(2) Filter cloth must be placed underneath the riprap as an additional requirement of its use in North Carolina waters; however, the prospective permittee may request a waiver from this requirement. The waiver request must be in writing. The Corps will only issue a waiver if the prospective permittee demonstrates that the impacts of complying with this requirement would result in greater adverse impacts to the aquatic environment. Note that filter fabric is not required if the riprap will be pushed or “keyed” into the bank of the waterbody.

(3) The placement of riprap shall be limited to the areas depicted on submitted work plan drawings.

(4) Riprap shall not be placed in a manner that prevents or impedes fish passage.

(5) Riprap shall be clean and free from loose dirt or any pollutant except in trace quantities that will not have an adverse environmental effect.

(6) Riprap shall be of a size sufficient to prevent its movement from the authorized alignment by natural forces under normal conditions.

(7) Riprap material shall consist of clean rock or masonry material such as, but not limited to, granite, marl, or broken concrete.

j. Discharges of dredged or fill material into waters of the U.S., including wetlands, must be minimized or avoided to the maximum extent practicable.

k. Generally, off-site detours are preferred to avoid and minimize impacts to the human and natural environment; however, if an off-site detour is considered impracticable, then an on-site detour may be considered as a necessary component of the actions authorized by this RGP. Impacts from the detour may be considered temporary and may not require compensatory mitigation if the impacted area is restored to pre-construction elevations and contours after construction is complete. The permittee shall also restore natural hydrology and stream corridors (if applicable), and reestablish native vegetation/riparian corridors. If the construction of a detour (on-site or off-site) includes standard undercutting methods, removal of all material and backfilling with suitable material is required. See special condition “s” for additional information.

l. All activities authorized by this RGP shall, to the maximum extent practicable, be

conducted "in the dry", with barriers installed between work areas and aquatic habitat to protect that habitat from sediment, concrete, and other pollutants. Where concrete is utilized, measures will be taken to prevent live or fresh concrete, including bags of uncured concrete, from coming into contact with waters of the U.S. until the concrete has set and cured. All water in the work area that has been in contact with concrete shall only be returned to waters of the U.S. when it no longer poses a threat to aquatic organisms (concrete is set and cured).

m. In cases where new alignment approaches are to be constructed and the existing approach fill in waters of the U.S. is to be abandoned and no longer maintained as a roadway, the abandoned fill shall be removed and the area will be restored to pre-construction elevations and contours. The permittee shall also restore natural hydrology and stream corridors (if applicable), and reestablish native vegetation/riparian corridors, to the extent practicable. This activity may qualify as compensatory mitigation credit for the project and will be assessed on a case-by-case basis in accordance with Special Conditions "q" and "r" in this document. Any proposed on-site wetland restoration area must be void of utility conflicts and/or utility maintenance areas. A restoration plan detailing this activity will be required with the submittal of the PCN.

n. To the maximum extent practicable, the pre-construction course, condition, capacity, and location of open waters must be maintained for each activity, including stream channelization and storm water management activities, except as provided below. The activity must be constructed to withstand expected high flows. The activity must not restrict or impede the passage of normal or high flows, unless the primary purpose of the activity is to impound water or manage high flows. The activity may alter the pre-construction course, condition, capacity, and location of open waters if it benefits the aquatic environment (e.g., stream restoration or relocation activities).

o. The project must be implemented and/or conducted so that all reasonable and practicable measures to ensure that equipment, structures, fill pads, and work associated with the project do not adversely affect upstream and/or downstream reaches. Adverse effects include, but are not limited to, channel instability, scour, flooding, and/or shoreline/streambank erosion. During construction, the permittee shall routinely monitor for these effects, cease all work if/when detected, take initial corrective measures to correct actively eroding areas, and notify the Corps immediately. Permanent corrective measures may require additional authorization from the Corps.

p. All PCNs will describe sedimentation and erosion control structures and measures proposed for placement in waters of the U.S. To the maximum extent practicable, structures and measures will be depicted on maps, surveys or drawings showing location and impacts to jurisdictional wetlands and streams. In addition, appropriate soil and erosion control measures must be established and maintained during construction. All fills, temporary and permanent, must be adequately stabilized at the earliest practicable date to prevent erosion of fill material into adjacent waters or wetlands.

q. Compensatory mitigation will be required for permanent impacts resulting in a loss of waters of the U.S. due to culvert/pipe installation and other similar activities. Mitigation may be required for stream relocation projects (see Special Condition “r” below). When compensatory mitigation is required, the prospective permittee will attach a proposed mitigation plan to the PCN. Compensatory mitigation proposals will be written in accordance with currently approved Wilmington District guidance and Corps mitigation regulations, unless the purchase of mitigation credits from an approved mitigation bank or the North Carolina Division of Mitigation Services (NCDMS) is proposed to address all compensatory mitigation requirements. The Corps Project Manager will make the final determination concerning the appropriate amount and type of mitigation.

r. Stream Relocations (non-tidal only) - for the purposes of permitting, stream relocations are considered a loss of waters of the U.S. Depending on the condition and location of (1) the existing stream, and (2) the relocated channel, stream relocation(s) may provide a functional uplift. The Corps will determine if an uplift is possible based on the information submitted with the PCN. If the anticipated uplift(s) occurs, it may offset, either partially or fully, the loss associated with a stream relocation(s) - (i.e., due to the uplift, either no compensatory mitigation would be required for the stream relocation itself, or compensatory mitigation would be required at a reduced ratio).

Because the amount of potential uplift is dependent upon the condition (or quality) of the channel to be relocated, there is no pre-determined amount of uplift needed to satisfy the requirements for a successful relocation project. After performing the evaluation(s) noted in this document, the prospective permittee will propose a certain amount of uplift potential and the Corps project manager will make the final determination. Baseline conditions and subsequent monitoring must show that the relocated channel is providing/will provide aquatic function at, or above, the level provided by the baseline (pre-project) condition. If the required uplift is not achieved, the work will not be in compliance with this special condition of RGP 50 and remediation will be required through repair (and continued monitoring), or by the permittee providing compensatory mitigation (e.g., mitigation credit through an approved bank, mitigation credit through NCDMS, etc.).

Compensatory mitigation, in addition to the stream relocation activity, may be required if the Corps determines that (a) no uplift in stream function is achievable, (b) the proposed uplift in stream function is not sufficient, by itself, (c) the risks associated with achieving potential uplifts in stream function are excessive, and/or (d) the time period for achieving the potential uplifts/functional success is too great.

On-site compensatory mitigation is not the same as stream relocation. While stream relocation simply moves a stream to a nearby, geographically similar area, it does not generate mitigation credits. If NCDOT proposes to generate compensatory mitigation on a project site, NCDOT must submit a mitigation plan that complies with 33 CFR 332.4.

The prospective permittee is required to submit the following information for any proposed project that involves stream relocation, regardless of the size/length of the stream relocation (note that 1-5 below only apply to stream relocations and not to compensatory mitigation):

- (1) A statement detailing why relocating the stream is unavoidable. In order to ensure that this action is separate from a compensatory mitigation project, the need for the fill must be related to road/interchange/intersection construction or improvement, and the project must meet the requirements set forth in the full descriptions/terms of “a” and “b” on pages 2 and 3 of this permit.
- (2) An evaluation of effects on the relocated stream and buffer from utilities, or potential for impact from utility placement in the future.
- (3) An evaluation of the baseline condition of the stream to be relocated. In order to demonstrate a potential uplift, the prospective permittee must provide the baseline (pre-impact) condition of the stream that is proposed for relocation. The prospective permittee will document the baseline condition of the stream by using the Corps’ (Wilmington District’s) current functional assessment method - e.g., the North Carolina Stream Assessment Method (NCSAM). The functional assessment must be used to identify specific areas where an uplift would reasonably be expected to occur, and also show important baseline functions that will remain after the relocation.
- (4) An evaluation of the potential uplifts to stream function for the relocated channel. The amount of detail required in the plan will be commensurate with the functional capacity of the original stream and proposed uplift(s). Low functional capacity will warrant less monitoring and less detail in the plan in order to ensure that the relocated channel provides the same, or better/increased, suite of aquatic functions as the existing channel.
- (5) A proposed monitoring plan for the relocated channel (and buffer, if applicable), will be prepared in accordance with current District guidance. The level of detail needed in the plan will be directly related to the quality of baseline functions and the anticipated uplift, therefore it is recommended that a pre-application discussion occur with the Corps Project Manager as early as possible. For example, if the risk for achieving the anticipated functional uplift is moderate or low, or if there is a low amount of proposed uplift, less information and monitoring will be required in the proposed relocation plan; similar to the requirements found in the "2003 Stream Mitigation Guidelines". If the risk for uplift is higher, or if there is a high amount of proposed uplift, additional monitoring and information will be required, trending toward the prescriptions found in the most recent Wilmington District Compensatory Mitigation Guidance – e.g., the 2016 Wilmington District Stream and Wetland Compensatory Mitigation Update. All monitoring will be for at least 5 years unless the Corps project manager determines that (a) a specific project requires less than 5 years due to site conditions or limited risk/uplift potential, and/or complexity (or simplicity) of the existing channel and/or the

P-16

relocation work, or (b) the Corps project manager determines (during the monitoring period) that the 5 years of monitoring may be reduced (or that no further monitoring is required) based on monitoring information received once the stream relocation has been completed.

s. Upon completion of any work authorized by this RGP, all temporary fills (to include culverts, pipes, causeways, etc.) will be completely removed from waters of the U.S. and the areas will be restored to pre-construction elevations and contours. The permittee shall also restore natural hydrology and stream corridors (if applicable), and reestablish native vegetation/riparian corridors. This work will be completed within 60 days of completion of project construction. If this timeframe occurs while a required moratorium of this permit is in effect, the temporary fill shall be removed in its entirety within 60 days of the moratorium end date. If vegetation cannot be planted due to the time of the year, all disturbed areas will be seeded with a native mix appropriate for the impacted area, and vegetation will be planted during the next appropriate time frame. A native seed mix may contain non-invasive small grain annuals (e.g. millet and rye grain) to ensure adequate cover while native vegetation becomes established. The PCN must include a restoration plan showing how all temporary fills and structures will be removed and how the area will be restored to pre-project elevations and contours.

t. Once the authorized work in waters of the U.S. is complete, the permittee shall sign and return the compliance certificate that is attached to the RGP verification letter.

u. The District Engineer will consider any comments from Federal and/or State agencies concerning the proposed activity's compliance with the terms and conditions of this RGP.

v. The Corps may place additional special conditions, limitations, or restrictions on any verification of the use of RGP 50 on a project-by-project basis.

2. General Conditions.

a. Except as authorized by this RGP or any Corps approved modification to this RGP, no excavation, fill or mechanized land-clearing activities shall take place within waters or wetlands, at any time during construction or maintenance of the project. This permit does not authorize temporary placement or double handling of excavated or fill material within waters or wetlands outside the permitted area. This prohibition applies to all borrow and fill activities connected with the project.

b. Authorization under this RGP does not obviate the need to obtain other federal, state, or local authorizations.

c. All work authorized by this RGP must comply with the terms and conditions of the applicable CWA Section 401 Water Quality Certification for this RGP issued by the North Carolina Division of Water Resources (NCDWR).

d. The permittee shall employ all sedimentation and erosion control measures necessary to prevent an increase in sedimentation or turbidity within waters and wetlands outside of the permit area. This shall include, but is not limited to, the immediate installation of silt fencing or similar appropriate devices around all areas subject to soil disturbance or the movement of earthen fill, and the immediate stabilization of all disturbed areas. Additionally, the project must remain in full compliance with all aspects of the Sedimentation Pollution Control Act of 1973 (North Carolina General Statutes Chapter 113A Article 4).

e. The activities authorized by this RGP must not interfere with the public's right to free navigation on all navigable waters of the U.S. No attempt will be made by the permittee to prevent the full and free use by the public of all navigable waters at, or adjacent to, the authorized work for a reason other than safety.

f. The permittee understands and agrees that if future operations by the U.S. require the removal, relocation, or other alteration, of the structure or work herein authorized, or if, in the opinion of the Secretary of the Army or his authorized representative, said structure or work shall cause unreasonable obstruction to the free navigation of the navigable waters, the permittee will be required, upon due notice from the Corps, to remove, relocate, or alter the structural work or obstructions caused thereby, without expense to the U.S. No claim shall be made against the U.S. on account of any such removal or alteration.

g. The permittee, upon receipt of a notice of revocation of this RGP for the verified individual activity, may apply for an individual permit, or will, without expense to the U.S. and in such time and manner as the Secretary of the Army or his/her authorized representative may direct, restore the affected water of the U.S. to its former conditions.

h. This RGP does not authorize any activity that would conflict with a federal project's congressionally authorized purposes, established limitations or restrictions, or limit an agency's ability to conduct necessary operation and maintenance functions. Per Section 14 of the Rivers and Harbors Act of 1899, as amended (33 U.S.C. 408), no project that has the potential to take possession of or make use of for any purpose, or build upon, alter, deface, destroy, move, injure, or obstruct a federally constructed work or project, including, but not limited to, levees, dams, jetties, navigation channels, borrow areas, dredged material disposal sites, flood control projects, etc., shall be permitted unless the project has been reviewed and approved by the appropriate Corps approval authority. Permittees shall not begin the activity authorized by this RGP until notified by the Corps that the activity may proceed.

i. The permittee shall obtain a Consent to Cross Government Easement from the appropriate Corps District's Land Use Coordinator prior to any crossing of a Corps easement and/or prior to commencing construction of any structures, authorized dredging, or other work within the right-of-way of, or in proximity to, a federally designated disposal area.

P-18

j. The permittee will allow the Wilmington District Engineer or his/her representative to inspect the authorized activity at any time deemed necessary to ensure that the activity is being performed or maintained in strict accordance with the Special and General Conditions of this permit.

k. This RGP does not grant any property rights or exclusive privileges.

l. This RGP does not authorize any injury to the property or rights of others.

m. This RGP does not authorize the interference with any existing or proposed federal project.

n. In issuing this permit, the Federal Government does not assume any liability for the following:

(1) Damages to the permitted project or uses thereof as a result of other permitted or unpermitted activities or from natural causes.

(2) Damages to the permitted project or uses thereof as a result of current or future activities undertaken by or on behalf of the U.S. in the public interest.

(3) Damages to persons, property, or to other permitted or unpermitted activities or structures caused by the activity authorized by this permit.

(4) Design or construction deficiencies associated with the permitted work.

(5) Damage claims associated with any future modification, suspension, or revocation of this permit.

o. Authorization provided by this RGP may be modified, suspended or revoked in whole, or in part, if the Wilmington District Engineer, acting for the Secretary of the Army, determines that such action would be in the best public interest. The term of this RGP shall be five (5) years unless subject to modification, suspension, or revocation. Any modification, suspension, or revocation of this authorization will not be the basis for any claim for damages against the U.S. Government.

p. No activity may occur in a component of the National Wild and Scenic Rivers System, or in a river officially designated by Congress as a "study river" for possible inclusion in the system while the river is in an official study status, unless the appropriate Federal agency with direct management responsibility for such river, has determined in writing that the proposed activity will not adversely affect the Wild and Scenic designation or study status. Information on Wild and Scenic Rivers may be obtained from the appropriate Federal land management agency responsible for the designated Wild and Scenic River or "study river" (e.g., National Park Service, U.S. Forest Service, etc.).

q. Endangered Species.

(1) No activity is authorized under this RGP which is likely to directly or indirectly jeopardize the continued existence of a threatened or endangered species or a species proposed for such designation, as identified under the Federal Endangered Species Act (ESA), or which will directly or indirectly destroy or adversely modify the critical habitat of such species. No activity is authorized under this RGP which “may affect” a listed species or critical habitat, unless Section 7 consultation addressing the effects of the proposed activity has been completed.

(2) Federal agencies should follow their own procedures for complying with the requirements of the ESA. Federal prospective permittees (and when FHWA is the lead federal agency) must provide the District Engineer with the appropriate documentation to demonstrate compliance with those requirements. The District Engineer will review the documentation and determine whether it is sufficient to address ESA compliance for the RGP activity, or whether additional ESA consultation is necessary.

(3) Non-federal prospective permittees - for activities that might affect federally-listed endangered or threatened species or designated critical habitat, the PCN must include the name(s) of the endangered or threatened species that might be affected by the proposed work or that utilize the designated critical habitat that might be affected by the proposed work. The District Engineer will determine whether the proposed activity “may affect” or will have “no effect” to listed species and designated critical habitat. In cases where the non-federal prospective permittee has identified listed species or critical habitat that might be affected or is in the vicinity of the project, and has so notified the Corps, the prospective permittee shall not begin work until the Corps has provided notification that the proposed activities will have “no effect” on listed species or critical habitat, or until Section 7 consultation has been completed.

(4) As a result of formal or informal consultation with the U.S. Fish and Wildlife Service (USFWS) or NMFS, the District Engineer may add species-specific endangered species conditions to the RGP verification letter for a project.

(5) Authorization of an activity by a RGP does not authorize the “take” of a threatened or endangered species as defined under the ESA. In the absence of separate authorization (e.g., an ESA Section 10 Permit, a Biological Opinion with “incidental take” provisions, etc.) from the USFWS or the NMFS, the ESA prohibits any person subject to the jurisdiction of the U.S. to take a listed species, where "take" means to harass, harm, pursue, hunt, shoot, wound, kill, trap, capture, or collect, or to attempt to engage in any such conduct. The word “harm” in the definition of “take” means an act which actually kills or injures wildlife. Such an act may include significant habitat modification or degradation where it actually kills or injures wildlife by significantly impairing essential behavioral patterns, including breeding, feeding or sheltering.

(6) Information on the location of threatened and endangered species and their critical habitat can be obtained directly from the offices of the USFWS in North Carolina at the addresses provided below, or from the USFWS and NMFS via their world wide web pages at <http://www.fws.gov/> or <http://www.fws.gov/ipac> and <http://www.noaa.gov/fisheries.html> respectively.

USFWS offices in North Carolina:

The Asheville USFWS Office covers all NC counties west of, and including, Anson, Stanly, Davidson, Forsyth and Stokes Counties.

US Fish and Wildlife Service
Asheville Field Office
160 Zillicoa Street
Asheville, NC 28801
Telephone: (828) 258-3939

The Raleigh USFWS Office covers all NC counties east of, and including, Richmond, Montgomery, Randolph, Guilford, and Rockingham Counties.

US Fish and Wildlife Service
Raleigh Field Office
Post Office Box 33726
Raleigh, NC 27636-3726
Telephone: (919) 856-4520

r. The Wilmington District, USFWS, NCDOT, and the FHWA have conducted programmatic Section 7(a)(2) consultation for a number of federally listed species and habitat, and programmatic consultation concerning other federally listed species and/or habitat may occur in the future. The result of completed programmatic consultation is a Programmatic Biological Opinion (PBO) issued by the USFWS. These PBOs contain mandatory terms and conditions to implement the reasonable and prudent measures that are associated with “incidental take” of whichever species or critical habitat is covered by a specific PBO. Authorization under RGP 50 is conditional upon the permittee’s compliance with all the mandatory terms and conditions associated with incidental take of the applicable PBO (or PBOs), which are incorporated by reference in RGP 50. Failure to comply with the terms and conditions associated with incidental take of an applicable PBO, where a take of the federally listed species occurs, would constitute an unauthorized take by the permittee, and would also constitute permittee non-compliance with the authorization under RGP 50. If the terms and conditions of a specific PBO (or PBOs) apply to a project, the Corps will include this/these requirements in any RGP 50 verification that may be issued for a project. The USFWS is the appropriate authority to determine compliance with the terms and conditions of its PBO, and with the ESA.

s. Northern long-eared bat (NLEB) (*Myotis septentrionalis*). Standard Local Operating Procedures for Endangered Species (SLOPES) for the NLEB have been approved by the Corps and the U.S. Fish and Wildlife Service. See <http://www.saw.usace.army.mil/Missions/Regulatory-Permit-Program/Agency-Coordination/ESA/>. This SLOPES details how the Corps will make determinations of effect to the NLEB when the Corps is the lead federal agency for an NCDOT project that is located in the western 41 counties of North Carolina. This SLOPES does not address NCDOT projects (either federal or state funded) in the eastern 59 counties in North Carolina. Note that if another federal agency is the lead federal agency for a project in the western 41 counties, procedures for satisfying the requirements of Section 7(a)(2) of the ESA will be dictated by that agency and will not be applicable for consideration under the SLOPES; however, information that demonstrates the lead federal agency's (if other than the Corps) compliance with Section 7(a)(2) / 4(d) Rule for the NLEB, will be required in the PCN. Note that at the time of issuance of RGP 50, the federal listing status of the NLEB as "Threatened" is being litigated at the National level. If, as a result of litigation, the NLEB is federally listed as "Endangered", this general condition ("s") will no longer be applicable because the 4(d) Rule, and this NLEB SLOPES, will no longer apply/be valid.

t. For proposed activities the sixteen (16) counties listed below, prospective permittees must provide a copy of the PCN to the USFWS, 160 Zillicoa Street, Asheville, North Carolina 28801. This PCN must be sent concurrently to the USFWS and the Corps Project Manager for that specific county.

The 16 counties with tributaries that drain to designated critical habitat that require notification to the Asheville USFWS are: Avery, Cherokee, Forsyth, Graham, Haywood, Henderson, Jackson, Macon Mecklenburg, Mitchell, Stokes, Surry, Swain, Transylvania, Union and Yancey.

u. If the permittee discovers or observes any live, damaged, injured or dead individual of an endangered or threatened species during construction, the permittee shall immediately notify the Wilmington District Engineer so that required coordination can be initiated with the U.S. Fish and Wildlife Service and/or National Marine Fisheries Service.

v. Historic Properties.

(1) In cases where the District Engineer determines that the activity may have the potential to cause effects to properties listed, or eligible for listing, in the National Register of Historic Places (NRHP), the activity is not authorized, until the requirements of Section 106 of the National Historic Preservation Act (NHPA) have been satisfied.

(2) Federal prospective permittees (or when FHWA is the lead federal agency) should follow their own procedures for complying with the requirements of Section 106 of the NHPA. Federal prospective permittees must provide the District Engineer with the appropriate documentation to demonstrate compliance with those requirements; this includes copies of correspondence sent to all interested, federally recognized tribes and a summary statement about

tribal consultation efforts or, if the Corps enters into a Programmatic Agreement (PA) with the FHWA/NCDOT, documentation that the FHWA/NCDOT has complied with PA requirements. The District Engineer will review the documentation and determine whether it is sufficient to address Section 106 compliance for this RGP activity, or whether additional Section 106 consultation is necessary.

(3) Non-federal prospective permittees - the PCN must state which historic properties may be affected by the proposed work or include a vicinity map indicating the location of the historic properties or the potential for the presence of historic properties. Assistance regarding information on the location of or potential for the presence of historic resources can be sought from the State Historic Preservation Officer (SHPO) and/or Tribal Historic Preservation Officer (THPO), as appropriate, and the NRHP (see 33 CFR 330.4(g)). When reviewing PCNs, the District Engineer will comply with the current procedures for addressing the requirements of Section 106 of the NHPA. The District Engineer shall make a reasonable and good faith effort to carry out appropriate identification efforts, which may include background research, consultation, oral history interviews, sample field investigation, and field survey. Based on the information submitted and these efforts, the District Engineer shall determine whether the proposed activity has the potential to cause an effect on the historic properties.

(4) Section 106 consultation is not required when the Corps determines that the activity does not have the potential to cause effects on historic properties (see 36 CFR §800.3(a)).

(5) Section 110k of the NHPA (16 U.S.C. 470h-2(k)) prevents the Corps from granting a permit or other assistance to a prospective permittee who, with intent to avoid the requirements of Section 106 of the NHPA, has intentionally significantly adversely affected a historic property to which the permit will relate, or having legal power to prevent it, allowed such significant adverse effect to occur, unless the Corps, after consultation with the Advisory Council on Historic Preservation (ACHP), determines that circumstances justify granting such assistance despite the adverse effect created or permitted by the prospective permittee. If circumstances justify granting the assistance, the Corps is required to notify the ACHP and provide documentation specifying the circumstances, the degree of damage to the integrity of any historic properties affected, and proposed mitigation. This documentation must include any views obtained from the prospective permittee, SHPO/THPO, appropriate Indian tribes if the undertaking occurs on or affects historic properties on tribal lands or affects properties of interest to those tribes, and other parties known to have a legitimate interest in the impacts to the permitted activity on historic properties.

w. If you discover any previously unknown historic or archeological remains while accomplishing the activity authorized by this general permit, you must immediately notify this office of what you have found. We will initiate the Federal and state coordination required to determine if the remains warrant a recovery effort or if the site is eligible for listing in the National Register of Historic Places.

x. Permittees are advised that development activities in or near a floodway may be subject to the National Flood Insurance Program that prohibits any development, including fill, within a floodway that results in any increase in base flood elevations. This general permit does not authorize any activity prohibited by the National Flood Insurance Program.

y. The permittee must install and maintain, at his/her expense, any signal lights and signals prescribed by the U.S. Coast Guard, through regulations or otherwise, on authorized facilities. For further information, the permittee should contact Coast Guard Sector North Carolina at (910) 772-2191 or email Coast Guard Fifth District at cgd5waterways@uscg.mil.

z. The permittee must maintain any structure or work authorized by this general permit in good condition and in conformance with the terms and conditions of this general permit. The permittee is not relieved of this requirement if the permittee abandons the structure or work. Transfer in fee simple of the work authorized by this general permit will automatically transfer this general permit to the property's new owner, with all of the rights and responsibilities enumerated herein. The permittee must inform any subsequent owner of all activities undertaken under the authority of this general permit and provide the subsequent owner with a copy of the terms and conditions of this general permit.

aa. At his or her sole discretion, any time during the processing cycle, the Wilmington District Engineer may determine that this general permit will not be applicable to a specific proposal. In such case, the procedures for processing an individual permit in accordance with 33 CFR 325 will be available.

bb. Except as authorized by this general permit or any Corps approved modification to this general permit, all fill material placed in waters or wetlands shall be generated from an upland source and will be clean and free of any pollutants except in trace quantities. Metal products, organic materials (including debris from land clearing activities), or unsightly debris will not be used.

cc. Except as authorized by this general permit or any Corps approved modification to this general permit, all excavated material will be disposed of in approved upland disposal areas.

dd. Activities which have commenced (i.e., are under construction) or are under contract to commence in reliance upon this general permit will remain authorized provided the activity is completed within twelve months of the date of the general permit's expiration, modification, or revocation. Activities completed under the authorization of this general permit that were in effect at the time the activity was completed continue to be authorized by the general permit.

ee. The permittee is responsible for obtaining any "take" permits required under the USFWS's regulations governing compliance with the Migratory Bird Treaty Act or the Bald and Golden Eagle Protection Act. The permittee should contact the appropriate local office of the USFWS to determine if such "take" permits are required for a particular activity.

ff. The activity must comply with applicable FEMA approved state or local floodplain management requirements.

gg. There will be no unreasonable interference with navigation or the right of the public to riparian access by the existence or use of activities authorized by this RGP.

hh. Unless authorization to fill those specific wetlands or mudflats has been issued by the Corps, heavy equipment working in wetlands or mudflats must be placed on mats, or other measures must be taken to minimize soil disturbance.

ii. This RGP will not be applicable to proposed construction when the Wilmington District Engineer determines that the proposed activity will significantly affect the quality of the human environment and determines that an EIS must be prepared.

BY AUTHORITY OF THE SECRETARY OF THE ARMY:

CLARK.ROBERT.J
AMES.10189013
03

Digitally signed by
CLARK.ROBERT.JAMES.1018
901303
Date: 2020.05.26 14:50:28
-04'00'

Robert J. Clark
Colonel, U. S. Army
District Commander

ROY COOPER
Governor
ELIZABETH S. BISER
Secretary
RICHARD E. ROGERS, JR.
Director



September 26, 2022

DWR # 20221186
Transylvania County

Mr. Kevin Barnett, Division Environmental Officer
NCDOT, Division 14
253 Webster Road
Sylvan, NC 28779

Subject: APPROVAL OF 401 WATER QUALITY CERTIFICATION WITH ADDITIONAL CONDITIONS
Intersection Improvements US64 NC 280 & 276 R-5799
Davidson River [French Broad River Basin, 06010105, WS-V, B; Trout]

Dear Mr. Barnett:

You have our approval for the impacts listed below for the purpose described in your application dated September 1, 2022 and received by the Division of Water Resources (Division) on September 1, 2022. These impacts are covered by the attached Water Quality General Certification Number 4135 and the conditions listed below. This certification is associated with the use of General Permit Number 201902350 once it is issued to you by the U.S. Army Corps of Engineers. Please note that you should get any other federal, state, or local permits before proceeding with your project, including those required by (but not limited to) Sediment and Erosion Control, Non-Discharge, and Water Supply Watershed regulations.

The Division has determined that the proposed project will comply with water quality requirements provided that you adhere to the conditions listed in the enclosed certification and to the additional conditions itemized below.

The following proposed impacts are hereby approved. No other impacts are approved, including incidental impacts. [15A NCAC 02H .0506(b)]

Stream Impacts in the French Broad River Basin

Site	Permanent Fill in Intermittent Stream (linear ft)	Temporary Fill in Intermittent Stream (linear ft)	Permanent Fill in Perennial Stream (linear ft)	Temporary Fill in Perennial Stream (linear ft)	Total Stream Impact (linear ft)	Stream Impacts Requiring Mitigation (linear ft)
S1			164		164	
S2				10	10	
S3			64		64	
S4				13	13	
S5			11		11	
S6				5	5	
S7				13	13	



Site	Permanent Fill in Intermittent Stream (linear ft)	Temporary Fill in Intermittent Stream (linear ft)	Permanent Fill in Perennial Stream (linear ft)	Temporary Fill in Perennial Stream (linear ft)	Total Stream Impact (linear ft)	Stream Impacts Requiring Mitigation (linear ft)
S8			45		45	
S9				15	15	
S10			17		17	
S11			35		35	
S12				12	12	
S13			35		35	
S14				12	12	
Total			371	80	451	0

Total Stream Impact for Project: 371 linear feet of permanent and 80 linear feet of temporary.

Wetland Impacts in the French Broad River Basin (Riverine)

Site	Fill (ac)	Fill (temporary) (ac)	Excavation (ac)	Mechanized Clearing (ac)	Hand Clearing (ac)	Total Wetland Impact (ac)
W1	0.01				0.01	0.02
Total	0.01				0.01	0.02

Total Wetland Impact for Project: 0.02 acres.

This approval is for the purpose and design described in your application. The plans and specifications for this project are incorporated by reference as part of this Certification. If you change your project, you must notify the Division and you may be required to submit a new application package with the appropriate fee. If the property is sold, the new owner must be given a copy of this Certification and is responsible for complying with all conditions. [15A NCAC 02H .0507(d)(2)].

If you are unable to comply with any of the conditions of the attached Water Quality General Certification or with the additional conditions itemized below, you must notify the Asheville Regional Office within 24 hours (or the next business day if a weekend or holiday) from the time the permittee becomes aware of the circumstances.

The permittee shall report to the Asheville Regional Office any noncompliance with, and/or any violation of, stream or wetland standards [15A NCAC 02B .0200] including but not limited to sediment impacts to streams or wetlands. Information shall be provided orally within 24 hours (or the next business day if a weekend or holiday) from the time the permittee became aware of the non-compliance circumstances.

Condition(s) of Certification:

Project Specific Conditions

1. The NCDOT Division Environmental Officer or Environmental Assistant will conduct a pre-construction meeting with all appropriate staff to ensure that the project supervisor and essential staff understand potential issues at the permitted site. NCDWR staff shall be invited to the pre-construction meeting. [15A NCAC 02H.0506(b)(2) and (b)(3)]
2. The permittee shall use Design Standards in Sensitive Watersheds (15A NCAC 4B.0124[a]-[e]) in areas draining to Trout waters. [15A NCAC 02H.0225 (d)(3)(B)]
3. The permittee will need to adhere to all appropriate in-water work moratoria (including the use of pile driving or vibration techniques) prescribed by the NC Wildlife Resources Commission. No in-water



work is permitted between October 15 and April 15 of any year, without prior approval from the NC Division of Water Resources and the NC Wildlife Resources Commission.

In-stream work and land disturbance within the 25-foot buffer zone are prohibited during the trout-spawning season of October 15 through April 15 to protect the egg and fry stages of trout.

General Conditions

1. Unless otherwise approved in this certification, placement of culverts and other structures in open waters and streams shall be placed below the elevation of the streambed by one foot for all culverts with a diameter greater than 48 inches, and 20 percent of the culvert diameter for culverts having a diameter less than 48 inches, to allow low flow passage of water and aquatic life. Design and placement of culverts and other structures including temporary erosion control measures shall not be conducted in a manner that may result in dis-equilibrium of wetlands or streambeds or banks, adjacent to or upstream and downstream of the above structures. The applicant is required to provide evidence that the equilibrium is being maintained if requested in writing by NCDWR. If this condition is unable to be met due to bedrock or other limiting features encountered during construction, please contact NCDWR for guidance on how to proceed and to determine whether or not a permit modification will be required. [15A NCAC 02H.0506(b)(2)]
2. If concrete is used during construction, a dry work area shall be maintained to prevent direct contact between curing concrete and stream water. Water that inadvertently contacts uncured concrete shall not be discharged to surface waters due to the potential for elevated pH and possible aquatic life and fish kills. [15A NCAC 02B.0200]
3. During the construction of the project, no staging of equipment of any kind is permitted in waters of the U.S. or protected riparian buffers. [15A NCAC 02H.0506(b)(2)]
4. The dimension, pattern, and profile of the stream above and below the crossing shall not be modified. Disturbed floodplains and streams shall be restored to natural geomorphic conditions. [15A NCAC 02H.0506(b)(2)]
5. The use of rip-rap above the Normal High Water Mark shall be minimized. Any rip-rap placed for stream stabilization shall be placed in stream channels in such a manner that it does not impede aquatic life passage. [15A NCAC 02H.0506(b)(2)]
6. The Permittee shall ensure that the final design drawings adhere to the permit and to the permit drawings submitted for approval. [15A NCAC 02H .0507(c) and 15A NCAC 02H .0506 (b)(2) and (c)(2)]
7. All work in or adjacent to stream waters shall be conducted in a dry work area. Approved BMP measures from the most current version of NCDOT Construction and Maintenance Activities manual such as sandbags, rock berms, cofferdams and other diversion structures shall be used to prevent excavation in flowing water. [15A NCAC 02H.0506(b)(3) and (c)(3)]
8. Heavy equipment shall be operated from the banks rather than in the stream channel in order to minimize sedimentation and reduce the introduction of other pollutants into the stream. [15A NCAC 02H.0506(b)(3)]
9. All mechanized equipment operated near surface waters must be regularly inspected and maintained to prevent contamination of stream waters from fuels, lubricants, hydraulic fluids, or other toxic materials. [15A NCAC 02H.0506(b)(3)]
10. No rock, sand or other materials shall be dredged from the stream channel except where authorized by this certification. [15A NCAC 02H.0506(b)(3)]



11. Discharging hydroseed mixtures and washing out hydro seeders and other equipment in or adjacent to surface waters is prohibited. [15A NCAC 02H.0506(b)(3)]
12. The permittee and its authorized agents shall conduct its activities in a manner consistent with State water quality standards (including any requirements resulting from compliance with §303(d) of the Clean Water Act) and any other appropriate requirements of State and Federal law. If the NCDWR determines that such standards or laws are not being met (including the failure to sustain a designated or achieved use) or that State or federal law is being violated, or that further conditions are necessary to assure compliance, the NCDWR may reevaluate and modify this certification. [15A NCAC 02B.0200]
13. All fill slopes located in jurisdictional wetlands shall be placed at slopes no flatter than 3:1, unless otherwise authorized by this certification. [15A NCAC 02H.0506(b)(2)]
14. A copy of this Water Quality Certification shall be maintained on the construction site at all times. In addition, the Water Quality Certification and all subsequent modifications, if any, shall be maintained with the Division Engineer and the on-site project manager. [15A NCAC 02H .0507(c) and 15A NCAC 02H .0506 (b)(2) and (c)(2)]
15. The outside buffer, wetland or water boundary located within the construction corridor approved by this authorization shall be clearly marked by highly visible fencing prior to any land disturbing activities. Impacts to areas within the fencing are prohibited unless otherwise authorized by this certification. [15A NCAC 02H.0501 and .0502]
16. The issuance of this certification does not exempt the Permittee from complying with any and all statutes, rules, regulations, or ordinances that may be imposed by other government agencies (i.e. local, state, and federal) having jurisdiction, including but not limited to applicable buffer rules, stormwater management rules, soil erosion and sedimentation control requirements, etc.
17. The Permittee shall report any violations of this certification to the Division of Water Resources within 24 hours of discovery. [15A NCAC 02B.0506(b)(2)]
18. Upon completion of the project (including any impacts at associated borrow or waste sites), the NCDOT Division Engineer shall complete and return the enclosed "Certification of Completion Form" to notify the NCDWR when all work included in the 401 Certification has been completed. [15A NCAC 02H.0502(f)]
19. Native riparian vegetation must be reestablished in the riparian areas within the construction limits of the project by the end of the growing season following completion of construction. [15A NCAC 02B.0506(b)(2)]
20. There shall be no excavation from, or waste disposal into, jurisdictional wetlands or waters associated with this permit without appropriate modification. Should waste or borrow sites, or access roads to waste or borrow sites, be located in wetlands or streams, compensatory mitigation will be required since that is a direct impact from road construction activities. [15A NCAC 02H.0506(b)(3) and (c)(3)]
21. Erosion and sediment control practices must be in full compliance with all specifications governing the proper design, installation and operation and maintenance of such Best Management Practices in order to protect surface waters standards [15A NCAC 02H.0506(b)(3) and (c)(3)]:
 - a. The erosion and sediment control measures for the project must be designed, installed, operated, and maintained in accordance with the most recent version of the *North Carolina Sediment and Erosion Control Planning and Design Manual*.
 - b. The design, installation, operation, and maintenance of the sediment and erosion control measures must be such that they equal, or exceed, the requirements specified in the most recent version of the *North Carolina Sediment and Erosion Control Manual*. The devices shall be maintained on all construction sites, borrow sites, and waste pile (spoil) projects, including contractor-owned or leased borrow pits associated with the project.



- c. For borrow pit sites, the erosion and sediment control measures must be designed, installed, operated, and maintained in accordance with the most recent version of the *North Carolina Surface Mining Manual*.
- d. The reclamation measures and implementation must comply with the reclamation in accordance with the requirements of the Sedimentation Pollution Control Act.

22. Sediment and erosion control measures shall not be placed in wetlands or waters unless otherwise approved by this Certification. [15A NCAC 02H.0506(b)(3) and (c)(3)]

This approval and its conditions are final and binding unless contested. [G.S. 143-215.5] This Certification can be contested as provided in Chapter 150B of the North Carolina General Statutes by filing a Petition for a Contested Case Hearing (Petition) with the North Carolina Office of Administrative Hearings (OAH) **within sixty (60) calendar days**. Requirements for filing a Petition are set forth in Chapter 150B of the North Carolina General Statutes and Title 26 of the North Carolina Administrative Code. Additional information regarding requirements for filing a Petition and Petition forms may be accessed at <http://www.ncoah.com/> or by calling the OAH Clerk's Office at (919) 431-3000.

One (1) copy of the Petition must also be served to the North Carolina Department of Environmental Quality:

William F. Lane, General Counsel
Department of Environmental Quality
1601 Mail Service Center
Raleigh, NC 27699-1601

This letter completes the review of the Division under section 401 of the Clean Water Act and 15A NCAC 02H .0500. Please contact Kevin Mitchell at 828-296-4650 or kevin.mitchell@ncdenr.gov if you have any questions or concerns.

Sincerely,

DocuSigned by:

Richard E. Rogers, Jr., Director
Division of Water Resources

ec: Crystal Amschler, US Army Corps of Engineers Asheville Regulatory Field Office (via email)
Dave McHenry, NC Wildlife Resources Commission (via email)
Holland Youngman, US Fish and Wildlife Service (via email)

File Copy



STATE OF NORTH CAROLINA
DEPARTMENT OF ENVIRONMENTAL QUALITY
DIVISION OF WATER RESOURCES

WATER QUALITY GENERAL CERTIFICATION NO. 4135

GENERAL CERTIFICATION FOR PROJECTS ELIGIBLE FOR US ARMY CORPS OF ENGINEERS

- **NATIONWIDE PERMIT NUMBER 14 (LINEAR TRANSPORTATION PROJECTS), AND**
- **REGIONAL GENERAL PERMIT 198200031 (NCDOT BRIDGES, WIDENING PROJECTS, INTERCHANGE IMPROVEMENTS)**

Water Quality Certification Number 4135 is issued in conformity with the requirements of Section 401, Public Laws 92-500 and 95-217 of the United States and subject to the North Carolina Regulations in 15A NCAC 02H .0500 and 15A NCAC 02B .0200 for the discharge of fill material to surface waters and wetland areas as described in 33 CFR 330 Appendix A (B) (14) of the US Army Corps of Engineers regulations and Regional General Permit 198200031.

The State of North Carolina certifies that the specified category of activity will not violate applicable portions of Sections 301, 302, 303, 306 and 307 of the Public Laws 92-500 and 95-217 if conducted in accordance with the conditions hereinafter set forth.

Effective date: December 1, 2017

Signed this day: December 1, 2017

By

A handwritten signature in black ink, appearing to read 'Linda Culpepper', is written over a solid horizontal line.

for Linda Culpepper
Interim Director

Activities meeting any one (1) of the following thresholds or circumstances require written approval for a 401 Water Quality Certification from the Division of Water Resources (DWR):

- a) If any of the conditions of this Certification (listed below) cannot be met; or
- b) Any temporary or permanent impacts to wetlands, open waters and/or streams, except for construction of a driveway to a single family residential lot that is determined to not be part of a larger common plan of development, as long as the driveway involves a travel lane of less than 25 feet and total stream impacts of less than 60 feet, including any topographic/slope stabilization or in-stream stabilization needed for the crossing; or
- c) Any stream relocation or stream restoration; or
- d) Any high-density project, as defined in 15A NCAC 02H .1003(2)(a) and by the density thresholds specified in 15A NCAC 02H .1017, which:
 - i. Disturbs one acre or more of land (including a project that disturbs less than one acre of land that is part of a larger common plan of development or sale); and
 - ii. Has permanent wetland, stream or open water impacts; and
 - iii. Is proposing new built-upon area; and
 - iv. Does not have a stormwater management plan reviewed and approved under a state stormwater program¹ or a state-approved local government stormwater program².

Projects that have vested rights, exemptions, or grandfathering from state or locally-implemented stormwater programs and projects that satisfy state or locally-implemented stormwater programs through use of community in-lieu programs **require written approval**; or

- e) Any permanent impacts to waters, or to wetlands adjacent to waters, designated as: ORW (including SAV), HQW (including PNA), SA, WS-1, WS-11, or North Carolina or National Wild and Scenic River.
- f) Any permanent impacts to waters, or to wetlands adjacent to waters, designated as Trout except for driveway projects that are below threshold (b) above provided that:
 - i. The impacts are not adjacent to any existing structures
 - ii. All conditions of this General Certification can be met, including adherence to any moratoriums as stated in Condition #10; and
 - iii. A *Notification of Work in Trout Watersheds Form* is submitted to the Division at least 60 days prior to commencement of work; or
- g) Any permanent impacts to coastal wetlands [15A NCAC 07H .0205], or Unique Wetlands (UWL); or
- h) Any impact associated with a Notice of Violation or an enforcement action for violation(s) of NC Wetland Rules (15A NCAC 02H .0500), NC Isolated Wetland Rules (15A NCAC 02H .1300), NC Surface Water or Wetland Standards (15A NCAC 02B .0200), or State Regulated Riparian Buffer Rules (15A NCAC 02B .0200); or

¹ e.g. Coastal Counties, HQW, ORW, or state-implemented Phase II NPDES

² e.g. Delegated Phase II NPDES, Water Supply Watershed, Nutrient-Sensitive Waters, or Universal Stormwater Management Program

GC4135

- i) Any impacts to subject water bodies and/or state regulated riparian buffers along subject water bodies in the Neuse, Tar-Pamlico, or Catawba River Basins or in the Randleman Lake, Jordan Lake or Goose Creek Watersheds (or any other basin or watershed with State Regulated Riparian Area Protection Rules [Buffer Rules] in effect at the time of application) *unless*:
 - i. The activities are listed as "EXEMPT" from these rules; or
 - ii. A Buffer Authorization Certificate is issued by the NC Division of Coastal Management (DCM); or
 - iii. A Buffer Authorization Certificate or a Minor Variance is issued by a delegated or designated local government implementing a state riparian buffer program pursuant to 143-215.23

Activities included in this General Certification that do not meet one of the thresholds listed above do not require written approval.

I. ACTIVITY SPECIFIC CONDITIONS:

1. If this Water Quality Certification is used to access residential, commercial or industrial building sites, then all parcels owned by the applicant that are part of the single and complete project authorized by this Certification must be buildable without additional impacts to streams or wetlands. If required in writing by DWR, the applicant shall provide evidence that the parcels are buildable without requiring additional impacts to wetlands, waters, or state regulated riparian buffers. [15A NCAC 02H .0506(b)(4) and (c)(4)]
2. For road and driveway construction purposes, this Certification shall only be utilized from natural high ground to natural high ground. [15A NCAC 02H .0506(b)(2) and (c)(2)]
3. Deed notifications or similar mechanisms shall be placed on all lots with retained jurisdictional wetlands, waters, and state regulated riparian buffers within the project boundaries in order to assure compliance with NC Wetland Rules (15A NCAC 02H .0500), NC Isolated Wetland Rules {15A NCAC 02H .1300), and/or State Regulated Riparian Buffer Rules (15A NCAC 02B .0200). These mechanisms shall be put in place at the time of recording of the property or individual parcels, whichever is appropriate. [15A NCAC 02H .0506(b)(4) and (c)(4)]
4. For the North Carolina Department of Transportation, compliance with the NCDOT's individual NPDES permit NCS000250 shall serve to satisfy this condition. All other high-density projects that trigger threshold item (d) above shall comply with one of the following requirements: [15A NCAC 02H .0506(b)(5) and (c)(5)]

GC4135

- a. Provide a completed Stormwater Management Plan (SMP) for review and approval, including all appropriate stormwater control measure (SCM) supplemental forms and associated items, that complies with the high-density development requirements of 15A NCAC 02H .1003. Stormwater management shall be provided throughout the entire project area in accordance with 15A NCAC 02H .1003. For the purposes of 15A NCAC 02H .1003(2)(a), density thresholds shall be determined in accordance with 15A NCAC 02H .1017.
- b. Provide documentation (including calculations, photos, etc.) that the project will not cause degradation of downstream surface waters. Documentation shall include a detailed analysis of the hydrological impacts from stormwater runoff when considering the volume and velocity of stormwater runoff from the project built upon area and the size and existing condition of the receiving stream(s).

Exceptions to this condition require application to and written approval from DWR.

II. GENERAL CONDITIONS:

1. When written authorization is required, the plans and specifications for the project are incorporated into the authorization by reference and are an enforceable part of the Certification. Any modifications to the project require notification to DWR and may require an application submittal to DWR with the appropriate fee. [15A NCAC 02H .0501 and .0502]
2. No waste, spoil, solids, or fill of any kind shall occur in wetlands or waters beyond the footprint of the impacts (including temporary impacts) as authorized in the written approval from DWR; or beyond the thresholds established for use of this Certification without written authorization. [15A NCAC 02H .0501 and .0502]

No removal of vegetation or other impacts of any kind shall occur to state regulated riparian buffers beyond the footprint of impacts approved in a Buffer Authorization or Variance or as listed as an exempt activity in the applicable riparian buffer rules. [15A NCAC 028 .0200]

3. In accordance with 15A NCAC 02H .0506(h) and Session Law 2017-10, compensatory mitigation may be required for losses of greater than 300 linear feet of perennial streams and/or greater than one (1) acre of wetlands. Impacts associated with the removal of a dam shall not require mitigation when the removal complies with the requirements of Part 3 of Article 21 in Chapter 143 of the North Carolina General Statutes. Impacts to isolated and other non-404 jurisdictional wetlands shall not be combined with 404 jurisdictional wetlands for the purpose of determining when impact thresholds trigger a mitigation requirement. For linear publicly owned and maintained transportation projects that are not determined to be part of a larger common plan of development by the US Army Corps of Engineers, compensatory mitigation may be required for losses of greater than 300 linear feet per perennial stream.

GC4135

Compensatory stream and/or wetland mitigation shall be proposed and completed in compliance with G.S. 143-214.11. For applicants proposing to conduct mitigation within a project site, a complete mitigation proposal developed in accordance with the most recent guidance issued by the US Army Corps of Engineers Wilmington District shall be submitted for review and approval with the application for impacts.

4. All activities shall be in compliance with any applicable State Regulated Riparian Buffer Rules in Chapter 2 of Title 15A.
5. When applicable, all construction activities shall be performed and maintained in full compliance with G.S. Chapter 113A Article 4 (Sediment and Pollution Control Act of 1973). Regardless of applicability of the Sediment and Pollution Control Act, all projects shall incorporate appropriate Best Management Practices for the control of sediment and erosion so that no violations of state water quality standards, statutes, or rules occur. [15A NCAC 02H .0506{b}(3) and (c)(3) and 15A NCAC 02B .0200]

Design, installation, operation, and maintenance of all sediment and erosion control measures shall be equal to or exceed the requirements specified in the most recent version of the *North Carolina Sediment and Erosion Control Manual*, or for linear transportation projects, the *NCDOT Sediment and Erosion Control Manual*.

All devices shall be maintained on all construction sites, borrow sites, and waste pile (spoil) sites, including contractor-owned or leased borrow pits associated with the project. Sufficient materials required for stabilization and/or repair of erosion control measures and stormwater routing and treatment shall be on site at all times.

For borrow pit sites, the erosion and sediment control measures shall be designed, installed, operated, and maintained in accordance with the most recent version of the *North Carolina Surface Mining Manual*. Reclamation measures and implementation shall comply with the reclamation in accordance with the requirements of the Sedimentation Pollution Control Act and the Mining Act of 1971.

If the project occurs in waters or watersheds classified as Primary Nursery Areas (PNAs), SA, WS-1, WS-11, High Quality Waters (HQW), or Outstanding Resource Waters (ORW), then the sedimentation and erosion control designs shall comply with the requirements set forth in 15A NCAC 04B .0124, *Design Standards in Sensitive Watersheds*.

6. Sediment and erosion control measures shall not be placed in wetlands or waters except within the footprint of temporary or permanent impacts authorized under this Certification. Exceptions to this condition require application to and written approval from DWR. [15A NCAC 02H .0501 and .0502]
7. Erosion control matting that incorporates plastic mesh and/or plastic twine shall not be used along streambanks or within wetlands. Exceptions to this condition require application to and written approval from DWR. [15A NCAC 02B .0201]

GC4135

8. An NPDES Construction Stormwater Permit (NCG010000) is required for construction projects that disturb one (1) or more acres of land. The NCG010000 Permit allows stormwater to be discharged during land disturbing construction activities as stipulated in the conditions of the permit. If the project is covered by this permit, full compliance with permit conditions including the erosion & sedimentation control plan, inspections and maintenance, self-monitoring, record keeping and reporting requirements is required. [15A NCAC 02H .0506(b)(5) and (c)(5)]

The North Carolina Department of Transportation (NCDOT) shall be required to be in full compliance with the conditions related to construction activities within the most recent version of their individual NPDES (NCS000250) stormwater permit. [15A NCAC 02H .0506(b)(5) and (c)(5)]

9. All work in or adjacent to streams shall be conducted so that the flowing stream does not come in contact with the disturbed area. Approved best management practices from the most current version of the *NC Sediment and Erosion Control Manual*, or the *NC DOT Construction and Maintenance Activities Manual*, such as sandbags, rock berms, cofferdams, and other diversion structures shall be used to minimize excavation in flowing water. Exceptions to this condition require application to and written approval from DWR. [15A NCAC 02H .0506(b)(3) and (c)(3)]

10. If activities must occur during periods of high biological activity (e.g. sea turtle nesting, fish spawning, or bird nesting), then biological monitoring may be required at the request of other state or federal agencies and coordinated with these activities. [15A NCAC 02H .0506 (b)(2) and 15A NCAC 04B .0125]

All moratoriums on construction activities established by the NC Wildlife Resources Commission (WRC), US Fish and Wildlife Service (USFWS), NC Division of Marine Fisheries (DMF), or National Marine Fisheries Service (NMFS) shall be implemented. Exceptions to this condition require written approval by the resource agency responsible for the given moratorium. A copy of the approval from the resource agency shall be forwarded to DWR.

Work within a designated trout watershed of North Carolina (as identified by the Wilmington District of the US Army Corps of Engineers), or identified state or federal endangered or threatened species habitat, shall be coordinated with the appropriate WRC, USFWS, NMFS, and/or DMF personnel.

11. Culverts shall be designed and installed in such a manner that the original stream profiles are not altered and allow for aquatic life movement during low flows. The dimension, pattern, and profile of the stream above and below a pipe or culvert shall not be modified by widening the stream channel or by reducing the depth of the stream in connection with the construction activity. The width, height, and gradient of a proposed culvert shall be such as to pass the average historical low flow and spring flow without adversely altering flow velocity. [15A NCAC 02H .0506(b)(2) and (c)(2)]

P-36

GC4135

Placement of culverts and other structures in streams shall be below the elevation of the streambed by one foot for all culverts with a diameter greater than 48 inches, and 20% of the culvert diameter for culverts having a diameter less than or equal to 48 inches, to allow low flow passage of water and aquatic life.

If multiple pipes or barrels are required, they shall be designed to mimic the existing stream cross section as closely as possible including pipes or barrels at flood plain elevation and/or sills where appropriate. Widening the stream channel shall be avoided.

When topographic constraints indicate culvert slopes of greater than 5%, culvert burial is not required, provided that all alternative options for flattening the slope have been investigated and aquatic life movement/connectivity has been provided when possible (e.g. rock ladders, cross vanes, etc.). Notification, including supporting documentation to include a location map of the culvert, culvert profile drawings, and slope calculations, shall be provided to DWR 60 calendar days prior to the installation of the culvert.

When bedrock is present in culvert locations, culvert burial is not required provided that there is sufficient documentation of the presence of bedrock. Notification, including supporting documentation such as, a location map of the culvert, geotechnical reports, photographs, etc. shall be provided to DWR a minimum of 60 calendar days prior to the installation of the culvert. If bedrock is discovered during construction, then DWR shall be notified by phone or email within 24 hours of discovery.

If other site-specific topographic constraints preclude the ability to bury the culverts as described above and/or it can be demonstrated that burying the culvert would result in destabilization of the channel, then exceptions to this condition require application to and written approval from DWR.

Installation of culverts in wetlands shall ensure continuity of water movement and be designed to adequately accommodate high water or flood conditions. When roadways, causeways, or other fill projects are constructed across FEMA-designated floodways or wetlands, openings such as culverts or bridges shall be provided to maintain the natural hydrology of the system as well as prevent constriction of the floodway that may result in destabilization of streams or wetlands.

The establishment of native woody vegetation and other soft stream bank stabilization techniques shall be used where practicable instead of rip-rap or other bank hardening methods.

12. Bridge deck drains shall not discharge directly into the stream. Stormwater shall be directed across the bridge and pre-treated through site-appropriate means to the maximum extent practicable (e.g. grassed swales, pre-formed scour holes, vegetated buffers, etc.) before entering the stream. Exceptions to this condition require application to and written approval from DWR. [ISA NCAC 02H .0506(b)(S)]

GC4135

13. Application of fertilizer to establish planted/seeded vegetation within disturbed riparian areas and/or wetlands shall be conducted at agronomic rates and shall comply with all other Federal, State and Local regulations. Fertilizer application shall be accomplished in a manner that minimizes the risk of contact between the fertilizer and surface waters. [15A NCAC 02B .0200 and 15A NCAC 02B .0231]
14. If concrete is used during construction, then all necessary measures shall be taken to prevent direct contact between uncured or curing concrete and waters of the state. Water that inadvertently contacts uncured concrete shall not be discharged to waters of the state. [15A NCAC 02B .0200]
15. All proposed and approved temporary fill and culverts shall be removed and the impacted area shall be returned to natural conditions within 60 calendar days after the temporary impact is no longer necessary. The impacted areas shall be restored to original grade, including each stream's original cross-sectional dimensions, planform pattern, and longitudinal bed profile. For projects that receive written approval, no temporary impacts are allowed beyond those included in the application and authorization. All temporarily impacted sites shall be restored and stabilized with native vegetation. [15A NCAC 02H .0506(b)(2) and (c)(2)]
16. All proposed and approved temporary pipes/culverts/rip-rap pads etc. in streams shall be installed as outlined in the most recent edition of the *North Carolina Sediment and Erosion Control Planning and Design Manual* or the *North Carolina Surface Mining Manual* or the *North Carolina Department of Transportation Best Management Practices for Construction and Maintenance Activities* so as not to restrict stream flow or cause dis-equilibrium during use of this Certification. [15A NCAC 02H .0506(b)(2) and (c)(2)]
17. Any rip-rap required for proper culvert placement, stream stabilization, or restoration of temporarily disturbed areas shall be restricted to the area directly impacted by the approved construction activity. All rip-rap shall be placed such that the original stream elevation and streambank contours are restored and maintained. Placement of rip-rap or other approved materials shall not result in de-stabilization of the stream bed or banks upstream or downstream of the area or in a manner that precludes aquatic life passage. [15A NCAC 02H .0506(b)(2)]
18. Any rip-rap used for stream or shoreline stabilization shall be of a size and density to prevent movement by wave, current action, or stream flows and shall consist of clean rock or masonry material free of debris or toxic pollutants. Rip-rap shall not be installed in the streambed except in specific areas required for velocity control and to ensure structural integrity of bank stabilization measures. [15A NCAC 02H .0506(b)(2)]
19. Applications for rip-rap groins proposed in accordance with 15A NCAC 07H .1401 (NC Division of Coastal Management General Permit for construction of Wooden and Rip-rap Groins in Estuarine and Public Trust Waters) shall meet all the specific conditions for design and construction specified in 15A NCAC 07H.1405.

P-38

GC4135

20. All mechanized equipment operated near surface waters shall be inspected and maintained regularly to prevent contamination of surface waters from fuels, lubricants, hydraulic fluids, or other toxic materials. Construction shall be staged in order to minimize the exposure of equipment to surface waters to the maximum extent practicable. Fueling, lubrication and general equipment maintenance shall be performed in a manner to prevent, to the maximum extent practicable, contamination of surface waters by fuels and oils. [15A NCAC 02H .0506{b}(3) and {c}(3) and 15A NCAC 02B .0211 {12}]
21. Heavy equipment working in wetlands shall be placed on mats or other measures shall be taken to minimize soil disturbance. [15A NCAC 02H .0506{b}(3) and {c}(3)]
22. In accordance with 143-215.85{b}, the applicant shall report any petroleum spill of 25 gallons or more; any spill regardless of amount that causes a sheen on surface waters; any petroleum spill regardless of amount occurring within 100 feet of surface waters; and any petroleum spill less than 25 gallons that cannot be cleaned up within 24 hours.
23. If an environmental document is required under the State Environmental Policy Act {SEPA}, then this General Certification is not valid until a Finding of No Significant Impact {FONSI} or Record of Decision {ROD} is issued by the State Clearinghouse. If an environmental document is required under the National Environmental Policy Act {NEPA}, then this General Certification is not valid until a Categorical Exclusion, the Final Environmental Assessment, or Final Environmental Impact Statement is published by the lead agency. [15A NCAC 01C .0107{a}]
24. This General Certification does not relieve the applicant of the responsibility to obtain all other required Federal, State, or Local approvals before proceeding with the project, including those required by, but not limited to, Sediment and Erosion Control, Non-Discharge, Water Supply Watershed, and Trout Buffer regulations.
25. The applicant and their authorized agents shall conduct all activities in a manner consistent with State water quality standards {including any requirements resulting from compliance with §303{d} of the Clean Water Act}, and any other appropriate requirements of State and Federal Law. If DWR determines that such standards or laws are not being met, including failure to sustain a designated or achieved use, or that State or Federal law is being violated, or that further conditions are necessary to assure compliance, then DWR may revoke or modify a written authorization associated with this General Water Quality Certification. [15A NCAC 02H .0507{d}]
26. The permittee shall require its contractors and/or agents to comply with the terms and conditions of this permit in the construction and maintenance of this project and shall provide each of its contractors and/or agents associated with the construction or maintenance of this project with a copy of this Certification. A copy of this Certification, including all conditions shall be available at the project site during the construction and maintenance of this project. [15A NCAC 02H .0507 {c} and 15A NCAC 02H .0506 {b}(2) and {c}(2)]

GC4135

27. When written authorization is required for use of this Certification, upon completion of all permitted impacts included within the approval and any subsequent modifications, the applicant shall be required to return a certificate of completion (available on the DWR website <https://edocs.deq.nc.gov/Forms/Certificate-of-Completion>). [15A NCAC 02H .0502(f)]
28. Additional site-specific conditions, including monitoring and/or modeling requirements, may be added to the written approval letter for projects proposed under this Water Quality Certification in order to ensure compliance with all applicable water quality and effluent standards. [15A NCAC 02H .0507(c)]
29. If the property or project is sold or transferred, the new permittee shall be given a copy of this Certification (and written authorization if applicable) and is responsible for complying with all conditions. [15A NCAC 02H .0501 and .0502]

111. GENERAL CERTIFICATION ADMINISTRATION:



1. In accordance with North Carolina General Statute 143-215.3D(e), written approval for a 401 Water Quality General Certification must include the appropriate fee. An applicant for a CAMA permit under Article 7 of Chapter 113A of the General Statutes for which a Water Quality Certification is required shall only make one payment to satisfy both agencies; the fee shall be as established by the Secretary in accordance with 143-215.3D(e)(7).
2. This Certification neither grants nor affirms any property right, license, or privilege in any waters, or any right of use in any waters. This Certification does not authorize any person to interfere with the riparian rights, littoral rights, or water use rights of any other person and this Certification does not create any prescriptive right or any right of priority regarding any usage of water. This Certification shall not be interposed as a defense in any action respecting the determination of riparian or littoral rights or other rights to water use. No consumptive user is deemed by virtue of this Certification to possess any prescriptive or other right of priority with respect to any other consumptive user regardless of the quantity of the withdrawal or the date on which the withdrawal was initiated or expanded.
3. This Certification grants permission to the Director, an authorized representative of the Director, or DWR staff, upon the presentation of proper credentials, to enter the property during normal business hours. [15A NCAC 02H .0502(e)]
4. This General Certification shall expire on the same day as the expiration date of the corresponding Nationwide Permit and/or Regional General Permit. The conditions in effect on the date of issuance of Certification for a specific project shall remain in effect for the life of the project, regardless of the expiration date of this Certification. This General Certification is rescinded when the US Army Corps of Engineers reauthorizes any of the corresponding Nationwide Permits and/or Regional General Permits or when deemed appropriate by the Director of the Division of Water Resources.

P-40

GC4135

5. Non-compliance with or violation of the conditions herein set forth by a specific project may result in revocation of this General Certification for the project and may also result in criminal and/or civil penalties.
6. The Director of the North Carolina Division of Water Resources may require submission of a formal application for Individual Certification for any project in this category of activity if it is deemed in the public's best interest or determined that the project is likely to have a significant adverse effect upon water quality, including state or federally listed endangered or threatened aquatic species, or degrade the waters so that existing uses of the water or downstream waters are precluded.

History Note: Water Quality Certification (WQC) Number 4135 issued December 1, 2017 replaces WQC Number 4088 issued March 3, 2017; WQC 3886 issued March 12, 2012; WQC Number 3820 issued April 6, 2010; WQC Number 3627 issued March 2007; WQC Number 3404 issued March 2003; WQC Number 3375 issued March 18, 2002; WQC Number 3289 issued June 1, 2000; WQC Number 3103 issued February 11, 1997; WQC Number 2732 issued May 1, 1992; WQC Number 2666 issued January 21, 1992; WQC Number 2177 issued November 5, 1987.

PROJECT REFERENCE NO.	R-2799	SHEET NO.	5
PROJECT NAME	ROCKY MOUNTAIN ENGINEERS	DATE	11/15/2011
ENGINEER'S SIGNATURE AND SEAL 		SURVEYOR'S SIGNATURE AND SEAL 	

RS&H
 REGISTERED PROFESSIONAL ENGINEERS
 1000 WEST 10TH AVENUE, SUITE 100
 DENVER, COLORADO 80202

PERMIT DRAWING
 SHEET 5 OF 16

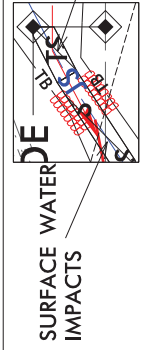
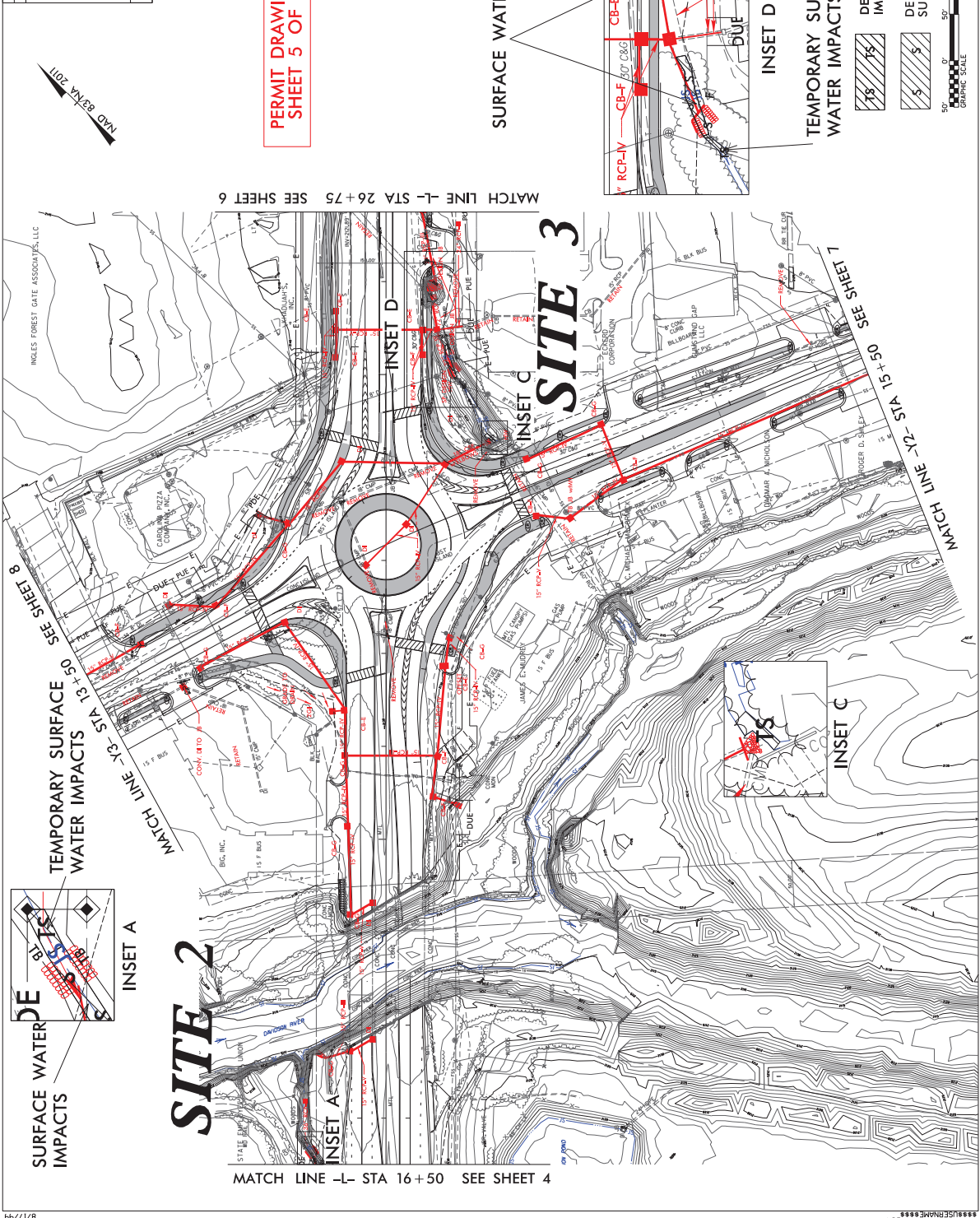

INSET A

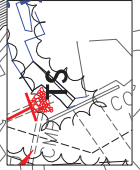

INSET C

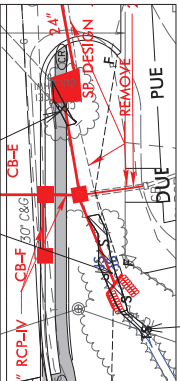

INSET D

SURFACE WATER IMPACTS

TEMPORARY SURFACE WATER IMPACTS

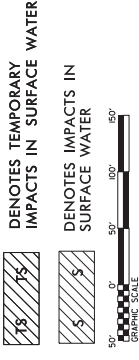

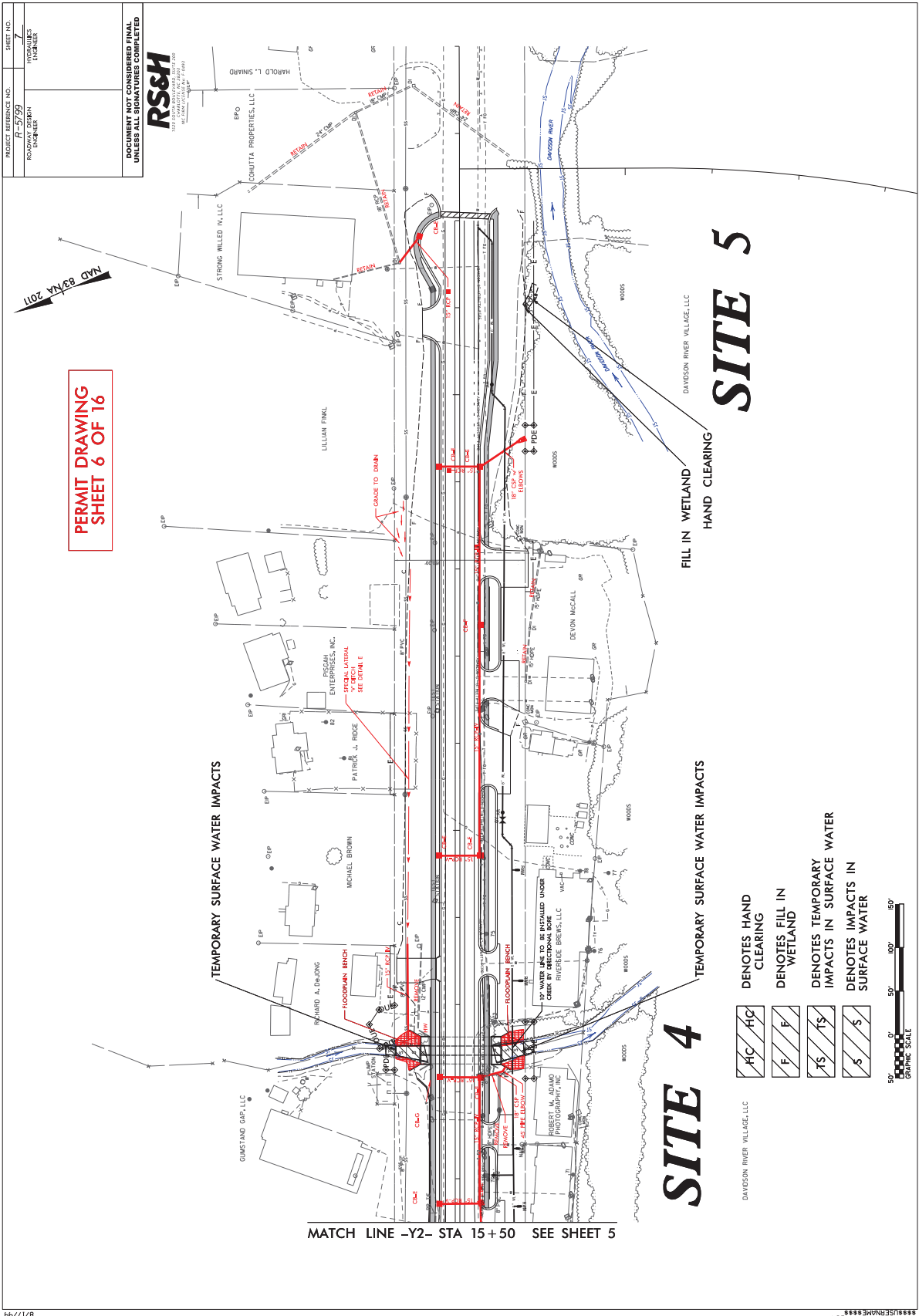

8/17/99

*****TIN*****

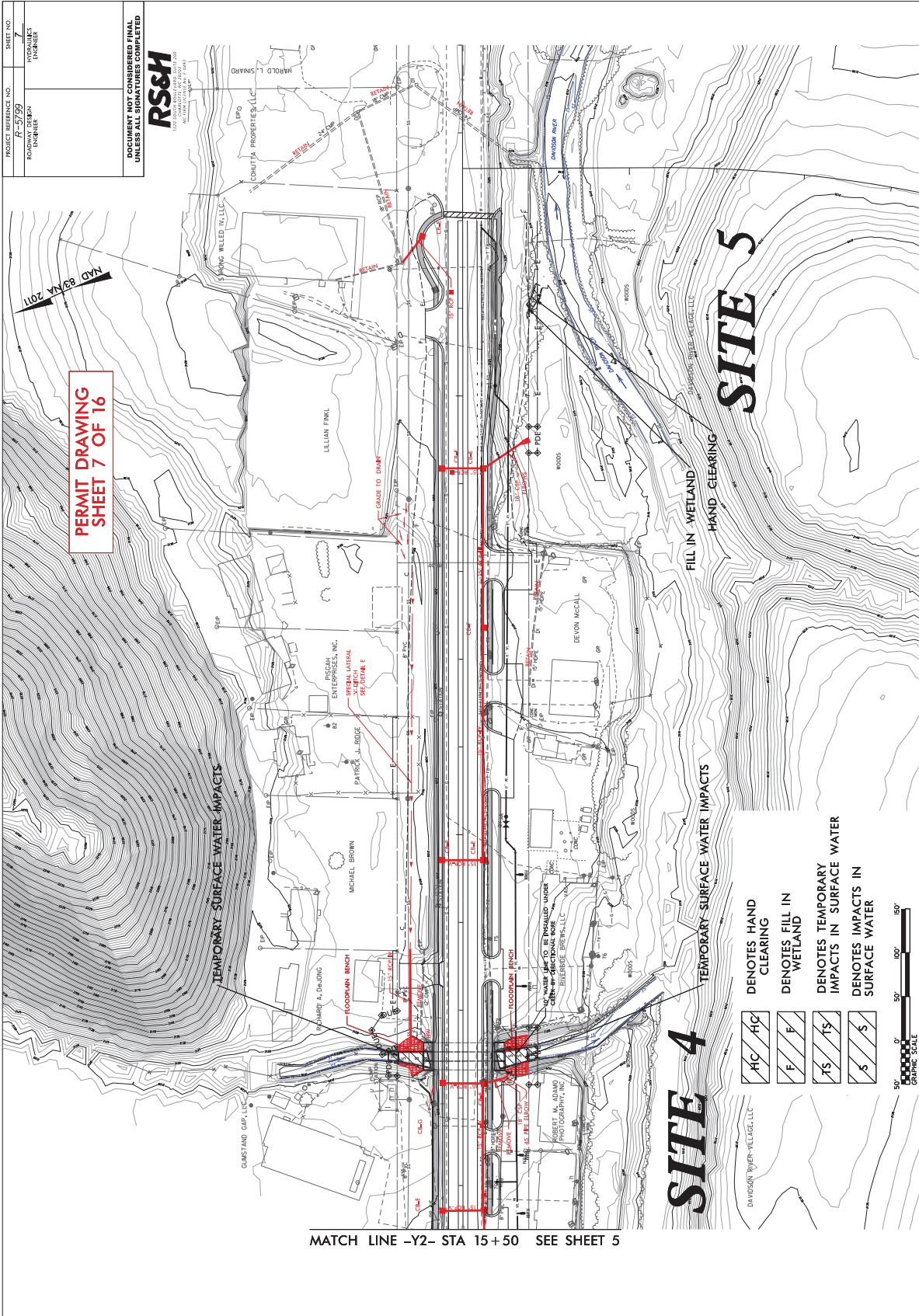

PROJECT REFERENCE NO. R-5799
 RICHARDSON ENGINEERS
 SHEET NO. 7
 DATE: 08/20/2011

NO SIGNATURES OR STAMPS ARE VALID UNLESS ALL SIGNATURES COMPLETED

RS&H
 REGISTERED PROFESSIONAL ENGINEERS
 STATE OF TEXAS
 LICENSE NO. 10580

PERMIT DRAWING
 SHEET 7 OF 16

MATCH LINE -Y2- STA 15+50 SEE SHEET 5

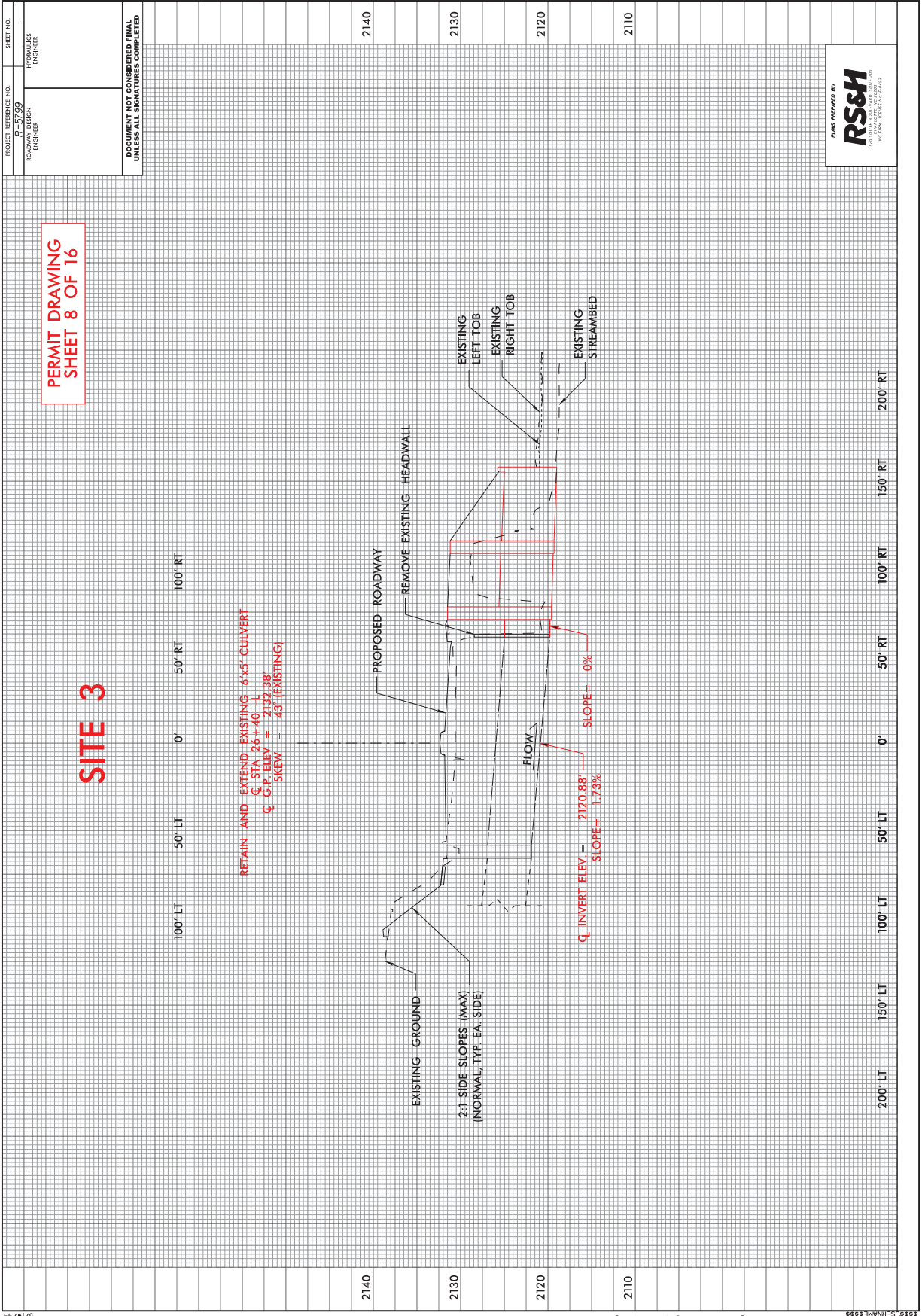

5/14/99
 29-Apr-2022 14:46
 I:\Projects\2022\22-001\Drawings\Environmental\Drawings\Site\5799\p.m.08.plt.dgn

PROJECT REFERENCE NO.
R-5799

DESIGNER
ROAD DESIGN
ENGINEER

SHEET NO.
PERMITS
ENGINEER

DOCUMENT NOT CONSIDERED FINAL
UNLESS ALL SIGNATURES COMPLETED



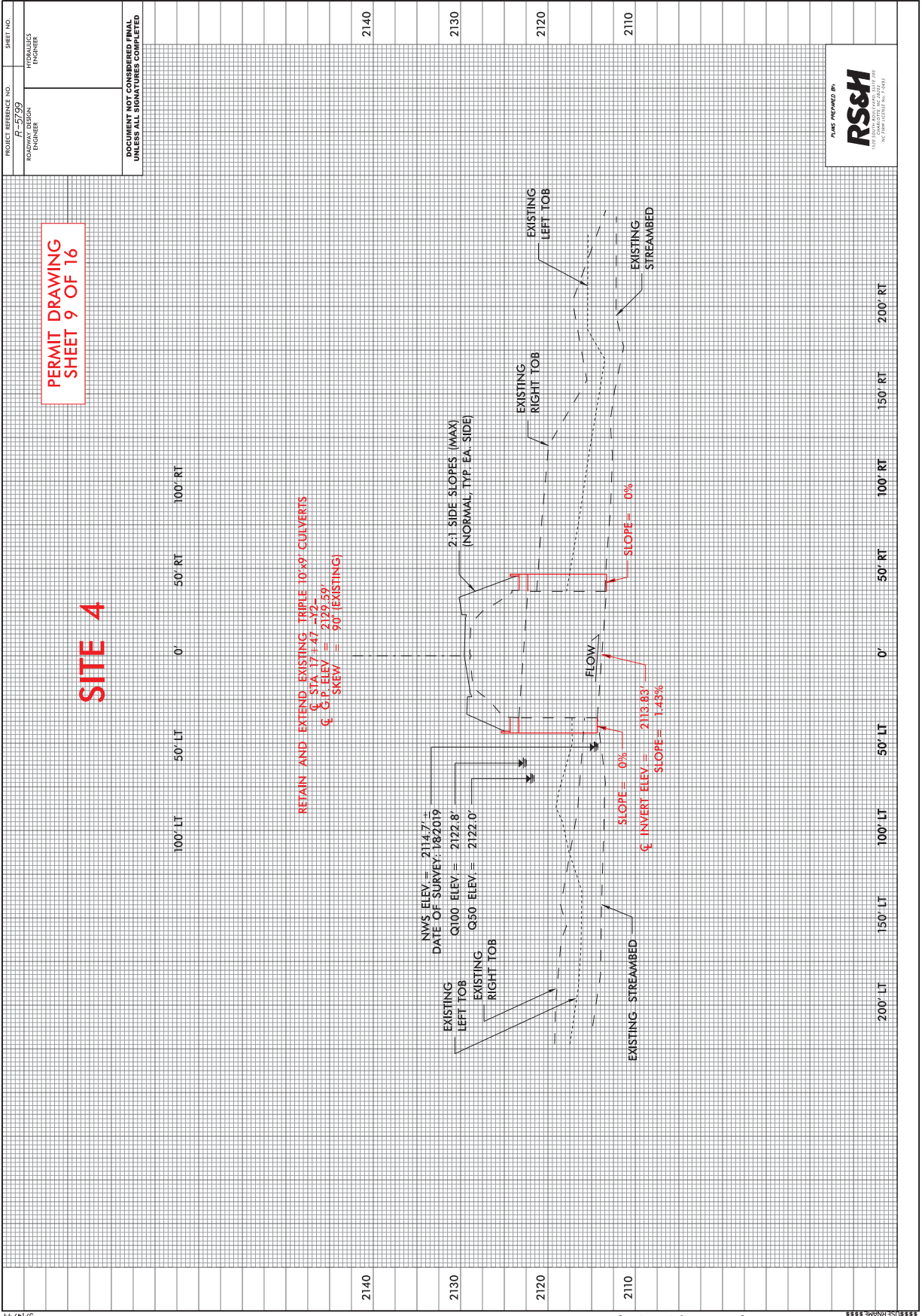

PERMIT DRAWING
SHEET 9 OF 16

SITE 4

PROJECT REFERENCE NO. R-5799	SHEET NO.
ROAD DESIGN ENGINEER	STATUS ENGINEER
DOCUMENT NOT CONSIDERED FINAL UNLESS ALL SIGNATURES COMPLETED	



2140

2130

2120

2110

200' LT 150' LT 100' LT 50' LT 0' 50' RT 100' RT 150' RT 200' RT

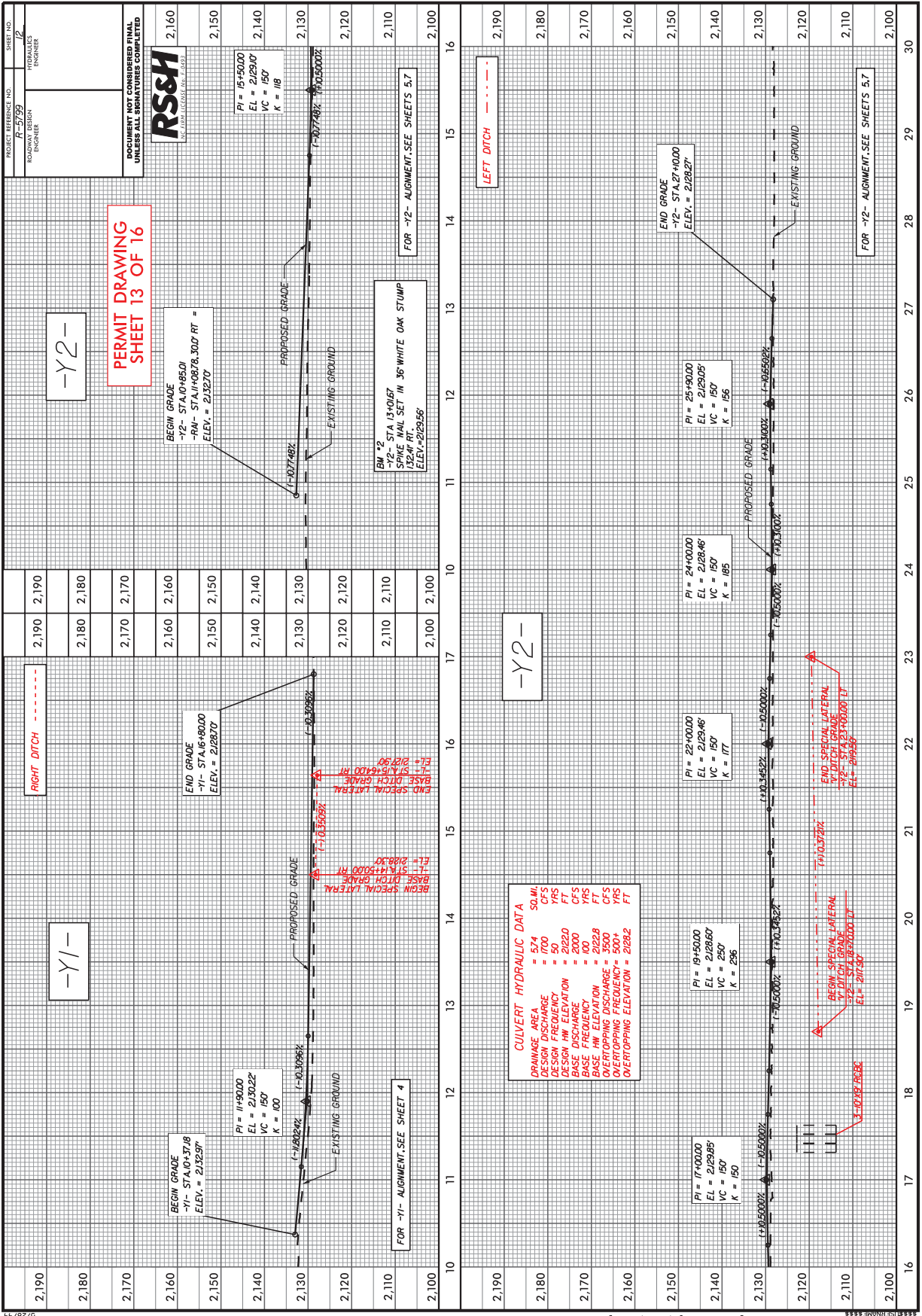

CULVERT HYDRAULIC DATA

DESIGN AREA	= 574	SQ. MI.
DESIGN FREQ	= 50	YRS
DESIGN HW ELEVATION	= 2125.0	FT
BASE DISCHARGE	= 2000	CFS
BASE HW ELEVATION	= 100	FT
OVERTOPPING FREQ	= 202.8	YRS
OVERTOPPING FREQ	= 500	YRS
OVERTOPPING ELEVATION	= 2128.2	FT

0 5 10
PROJ. REFERENCE NO. R-5799
SHEET NO. X-1

PERMIT DRAWING
SHEET 15 OF 16

SITE 5

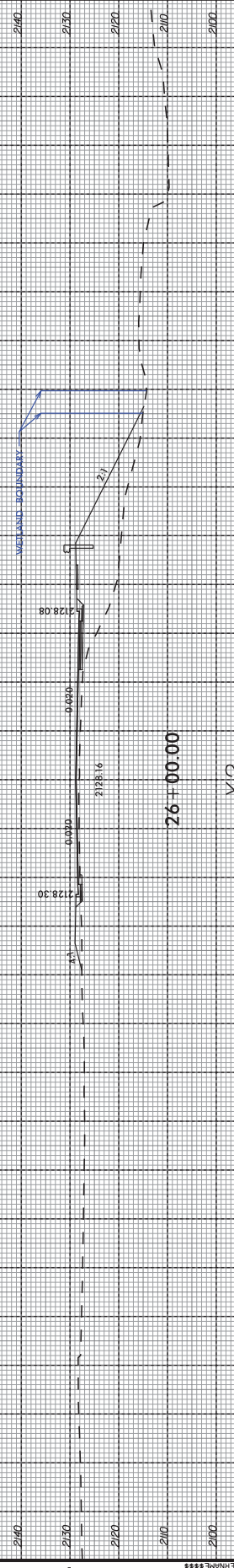

County: TRANSYLVANIA

Line #	Item Number	Sec #	Description	Quantity	Unit Cost	Amount
ROADWAY ITEMS						
0001	0000100000-N	800	MOBILIZATION	Lump Sum	L.S.	
0002	0000400000-N	801	CONSTRUCTION SURVEYING	Lump Sum	L.S.	
0003	0036000000-E	225	UNDERCUT EXCAVATION	1,450 CY		
0004	0050000000-E	226	SUPPLEMENTARY CLEARING & GRUBBING	1 ACR		
0005	0063000000-N	SP	GRADING	Lump Sum	L.S.	
0006	0106000000-E	230	BORROW EXCAVATION	23,750 CY		
0007	0127000000-N	235	EMBANKMENT SETTLEMENT GAUGES	3 EA		
0008	0195000000-E	265	SELECT GRANULAR MATERIAL	1,000 CY		
0009	0196000000-E	270	GEOTEXTILE FOR SOIL STABILIZATION	2,000 SY		
0010	0199000000-E	SP	TEMPORARY SHORING	2,300 SF		
0011	0223000000-E	275	ROCK PLATING	30 SY		
0012	0318000000-E	300	FOUNDATION CONDITIONING MATERIAL, MINOR STRUCTURES	930 TON		
0013	0320000000-E	300	FOUNDATION CONDITIONING GEOTEXTILE	2,910 SY		
0014	0342000000-E	310	*** SIDE DRAIN PIPE (12")	50 LF		
0015	0343000000-E	310	15" SIDE DRAIN PIPE	80 LF		
0016	0345000000-E	310	24" SIDE DRAIN PIPE	44 LF		
0017	0354000000-E	310	**** RC PIPE CULVERTS, CLASS ***** (15", V)	1,124 LF		

County: TRANSYLVANIA

Line #	Item Number	Sec #	Description	Quantity	Unit Cost	Amount
0018	0354000000-E	310	**** RC PIPE CULVERTS, CLASS ***** (18", V)	360 LF		
0019	0354000000-E	310	**** RC PIPE CULVERTS, CLASS ***** (24", V)	124 LF		
0020	0354000000-E	310	**** RC PIPE CULVERTS, CLASS ***** (30", V)	44 LF		
0021	0366000000-E	310	15" RC PIPE CULVERTS, CLASS III	552 LF		
0022	0372000000-E	310	18" RC PIPE CULVERTS, CLASS III	516 LF		
0023	0378000000-E	310	24" RC PIPE CULVERTS, CLASS III	368 LF		
0024	0390000000-E	310	36" RC PIPE CULVERTS, CLASS III	144 LF		
0025	0408000000-E	310	54" RC PIPE CULVERTS, CLASS III	128 LF		
0026	0426000000-E	310	72" RC PIPE CULVERTS, CLASS III	77 LF		
0027	0448200000-E	310	15" RC PIPE CULVERTS, CLASS IV	2,904 LF		
0028	0448300000-E	310	18" RC PIPE CULVERTS, CLASS IV	116 LF		
0029	0448400000-E	310	24" RC PIPE CULVERTS, CLASS IV	436 LF		
0030	0448500000-E	310	30" RC PIPE CULVERTS, CLASS IV	664 LF		
0031	0588000000-E	310	18" CS PIPE CULVERTS, 0.064" THICK	140 LF		
0032	0636000000-E	310	*** CS PIPE ELBOWS, ***** THICK (18", 0.064")	4 EA		
0033	0995000000-E	340	PIPE REMOVAL	3,106 LF		
0034	1099500000-E	505	SHALLOW UNDERCUT	500 CY		

County: TRANSYLVANIA

Line #	Item Number	Sec #	Description	Quantity	Unit Cost	Amount
0035	1099700000-E	505	CLASS IV SUBGRADE STABILIZATION	1,000 TON		
0036	1220000000-E	545	INCIDENTAL STONE BASE	250 TON		
0037	1308000000-E	607	MILLING ASPHALT PAVEMENT, **** TO ***** (0" TO 1-1/2")	1,690 SY		
0038	1308000000-E	607	MILLING ASPHALT PAVEMENT, **** TO ***** (0" TO 1-1/4")	200 SY		
0039	1330000000-E	607	INCIDENTAL MILLING	1,500 SY		
0040	1503000000-E	610	ASPHALT CONC INTERMEDIATE COURSE, TYPE I19.0C	10,450 TON		
0041	1519000000-E	610	ASPHALT CONC SURFACE COURSE, TYPE S9.5B	8,680 TON		
0042	1693000000-E	654	ASPHALT PLANT MIX, PAVEMENT REPAIR	2,510 TON		
0043	2044000000-E	815	6" PERFORATED SUBDRAIN PIPE	1,000 LF		
0044	2209000000-E	838	ENDWALLS	2 CY		
0045	2220000000-E	838	REINFORCED ENDWALLS	8 CY		
0046	2253000000-E	840	PIPE COLLARS	2.98 CY		
0047	2264000000-E	840	PIPE PLUGS	0.3 CY		
0048	2275000000-E	SP	FLOWABLE FILL	10 CY		
0049	2286000000-N	840	MASONRY DRAINAGE STRUCTURES	101 EA		
0050	2297000000-E	840	MASONRY DRAINAGE STRUCTURES	59 CY		
0051	2308000000-E	840	MASONRY DRAINAGE STRUCTURES	23 LF		

County: TRANSYLVANIA

Line #	Item Number	Sec #	Description	Quantity	Unit Cost	Amount
0052	2364000000-N	840	FRAME WITH TWO GRATES, STD 840.16	23 EA		
0053	2366000000-N	840	FRAME WITH TWO GRATES, STD 840.24	1 EA		
0054	2367000000-N	840	FRAME WITH TWO GRATES, STD 840.29	1 EA		
0055	2374000000-N	840	FRAME WITH GRATE & HOOD, STD 840.03, TYPE ** (E)	21 EA		
0056	2374000000-N	840	FRAME WITH GRATE & HOOD, STD 840.03, TYPE ** (F)	27 EA		
0057	2374000000-N	840	FRAME WITH GRATE & HOOD, STD 840.03, TYPE ** (G)	27 EA		
0058	2396000000-N	840	FRAME WITH COVER, STD 840.54	7 EA		
0059	2451000000-N	852	CONCRETE TRANSITIONAL SECTION FOR DROP INLET	8 EA		
0060	2535000000-E	846	*** X *** CONCRETE CURB (8" X 18")	1,130 LF		
0061	2535000000-E	846	*** X *** CONCRETE CURB (9" X 18")	470 LF		
0062	2542000000-E	846	1'-6" CONCRETE CURB & GUTTER	2,890 LF		
0063	2549000000-E	846	2'-6" CONCRETE CURB & GUTTER	11,650 LF		
0064	2591000000-E	848	4" CONCRETE SIDEWALK	5,510 SY		
0065	2605000000-N	848	CONCRETE CURB RAMPS	84 EA		
0066	2612000000-E	848	6" CONCRETE DRIVEWAY	320 SY		
0067	2655000000-E	852	5" MONOLITHIC CONCRETE ISLANDS (KEYED IN)	1,040 SY		

County: TRANSYLVANIA

Line #	Item Number	Sec #	Description	Quantity	Unit Cost	Amount
0068	2738000000-E	SP	GENERIC PAVING ITEM 7" JOINTED CONCRETE TRUCK APRON WITH WIRE MESH	1,270 SY		
0069	2815000000-N	858	ADJUSTMENT OF DROP INLETS	1 EA		
0070	2830000000-N	858	ADJUSTMENT OF MANHOLES	4 EA		
0071	2860000000-N	859	CONVERT EXISTING CATCH BASIN TO JUNCTION BOX	2 EA		
0072	2905000000-N	859	CONVERT EXISTING DROP INLET TO JUNCTION BOX	2 EA		
0073	2920000000-N	859	CONVERT EXISTING DROP INLET TO CATCH BASIN	1 EA		
0074	3030000000-E	862	STEEL BEAM GUARDRAIL	2,250 LF		
0075	3045000000-E	862	STEEL BEAM GUARDRAIL, SHOP CURVED	25 LF		
0076	3150000000-N	862	ADDITIONAL GUARDRAIL POSTS	10 EA		
0077	3180000000-N	SP	GUARDRAIL ANCHOR UNITS, TYPE ***** (III, SHOP CURVED)	1 EA		
0078	3210000000-N	862	GUARDRAIL END UNITS, TYPE CAT-1	8 EA		
0079	3215000000-N	SP	GUARDRAIL ANCHOR UNITS, TYPE III	8 EA		
0080	3287000000-N	SP	GUARDRAIL END UNITS, TYPE TL-3	2 EA		
0081	3288000000-N	SP	GUARDRAIL END UNITS, TYPE TL-2	17 EA		
0082	3575000000-E	SP	GENERIC FENCING ITEM HANDRAIL	930 LF		
0083	3628000000-E	876	RIP RAP, CLASS I	189 TON		
0084	3649000000-E	876	RIP RAP, CLASS B	112 TON		

County: TRANSYLVANIA

Line #	Item Number	Sec #	Description	Quantity	Unit Cost	Amount
0085	3656000000-E	876	GEOTEXTILE FOR DRAINAGE	1,254 SY		
0086	4054000000-E	902	PLAIN CONCRETE SIGN FOUNDATIONS	1 CY		
0087	4060000000-E	903	SUPPORTS, BREAKAWAY STEEL BEAM	204 LB		
0088	4072000000-E	903	SUPPORTS, 3-LB STEEL U-CHANNEL	1,410 LF		
0089	4096000000-N	904	SIGN ERECTION, TYPE D	11 EA		
0090	4102000000-N	904	SIGN ERECTION, TYPE E	109 EA		
0091	4108000000-N	904	SIGN ERECTION, TYPE F	13 EA		
0092	4110000000-N	904	SIGN ERECTION, TYPE *** (GROUND MOUNTED) (A)	1 EA		
0093	4116100000-N	904	SIGN ERECTION, RELOCATE TYPE **** (GROUND MOUNTED) (D)	27 EA		
0094	4138000000-N	907	DISPOSAL OF SUPPORT, STEEL BEAM	2 EA		
0095	4155000000-N	907	DISPOSAL OF SIGN SYSTEM, U-CHANNEL	46 EA		
0096	4192000000-N	907	DISPOSAL OF SUPPORT, U-CHANNEL	20 EA		
0097	4236000000-N	907	DISPOSAL OF SIGN, A & B (GROUND MOUNTED)	1 EA		
0098	4238000000-N	907	DISPOSAL OF SIGN, D, E OR F	17 EA		
0099	4360000000-N	SP	GENERIC SIGNING ITEM END OF MEDIAN MARKER	2 EA		
0100	4400000000-E	1110	WORK ZONE SIGNS (STATIONARY)	348 SF		
0101	4405000000-E	1110	WORK ZONE SIGNS (PORTABLE)	336 SF		

County: TRANSYLVANIA

Line #	Item Number	Sec #	Description	Quantity	Unit Cost	Amount
0102	4410000000-E	1110	WORK ZONE SIGNS (BARRICADE MOUNTED)	234 SF		
0103	4415000000-N	1115	FLASHING ARROW BOARD	2 EA		
0104	4420000000-N	1120	PORTABLE CHANGEABLE MESSAGE SIGN	4 EA		
0105	4430000000-N	1130	DRUMS	300 EA		
0106	4434000000-N	SP	SEQUENTIAL FLASHING WARNING LIGHTS	50 EA		
0107	4445000000-E	1145	BARRICADES (TYPE III)	80 LF		
0108	4447000000-E	SP	PEDESTRIAN CHANNELIZING DEVICES	180 LF		
0109	4455000000-N	1150	FLAGGER	170 DAY		
0110	4465000000-N	1160	TEMPORARY CRASH CUSHIONS	2 EA		
0111	4480000000-N	1165	TMA	2 EA		
0112	4490000000-E	1170	PORTABLE CONCRETE BARRIER (ANCHORED)	450 LF		
0113	4510000000-N	1190	LAW ENFORCEMENT	320 HR		
0114	4600000000-N	SP	GENERIC TRAFFIC CONTROL ITEM AUDIBLE WARNING DEVICES	8 EA		
0115	4685000000-E	1205	THERMOPLASTIC PAVEMENT MARKING LINES (4", 90 MILS)	19,903 LF		
0116	4695000000-E	1205	THERMOPLASTIC PAVEMENT MARKING LINES (8", 90 MILS)	4,854 LF		
0117	4709000000-E	1205	THERMOPLASTIC PAVEMENT MARKING LINES (24", 90 MILS)	2,209 LF		
0118	4720000000-E	1205	THERMOPLASTIC PAVEMENT MARKING CHARACTER (90 MILS)	12 EA		

County: TRANSYLVANIA

Line #	Item Number	Sec #	Description	Quantity	Unit Cost	Amount
0119	4725000000-E	1205	THERMOPLASTIC PAVEMENT MARKING SYMBOL (90 MILS)	168 EA		
0120	4726110000-E	1205	HEATED-IN-PLACE THERMOPLASTIC PAVEMENT MARKING SYMBOL (90 MILS)	60 EA		
0121	4810000000-E	1205	PAINT PAVEMENT MARKING LINES (4")	14,360 LF		
0122	4815000000-E	1205	PAINT PAVEMENT MARKING LINES (6")	1,099 LF		
0123	4820000000-E	1205	PAINT PAVEMENT MARKING LINES (8")	2,697 LF		
0124	4835000000-E	1205	PAINT PAVEMENT MARKING LINES (24")	697 LF		
0125	4840000000-N	1205	PAINT PAVEMENT MARKING CHARACTER	4 EA		
0126	4845000000-N	1205	PAINT PAVEMENT MARKING SYMBOL	31 EA		
0127	4850000000-E	1205	REMOVAL OF PAVEMENT MARKING LINES (4")	8,244 LF		
0128	4860000000-E	1205	REMOVAL OF PAVEMENT MARKING LINES (8")	1,400 LF		
0129	4870000000-E	1205	REMOVAL OF PAVEMENT MARKING LINES (24")	325 LF		
0130	4875000000-N	1205	REMOVAL OF PAVEMENT MARKING SYMBOLS & CHARACTERS	26 EA		
0131	4905100000-N	SP	NON-CAST IRON SNOWPLOWABLE PAVEMENT MARKER	626 EA		
0132	5255000000-N	1413	PORTABLE LIGHTING	Lump Sum	L.S.	
0133	5325200000-E	1510	2" WATER LINE	173 LF		
0134	5325600000-E	1510	6" WATER LINE	69 LF		
0135	5325800000-E	1510	8" WATER LINE	359 LF		

County: TRANSYLVANIA

Line #	Item Number	Sec #	Description	Quantity	Unit Cost	Amount
0136	5326000000-E	1510	10" WATER LINE	3,665 LF		
0137	5326200000-E	1510	12" WATER LINE	328 LF		
0138	5329000000-E	1510	DUCTILE IRON WATER PIPE FITTINGS	11,040 LB		
0139	5536000000-E	1515	2" VALVE	1 EA		
0140	5538000000-E	1515	4" VALVE	1 EA		
0141	5540000000-E	1515	6" VALVE	6 EA		
0142	5546000000-E	1515	8" VALVE	1 EA		
0143	5552000000-E	1515	10" VALVE	12 EA		
0144	5572000000-E	1515	10" TAPPING SLEEVE & VALVE	3 EA		
0145	5589100000-E	1515	1" AIR RELEASE VALVE	9 EA		
0146	5648000000-N	1515	RELOCATE WATER METER	30 EA		
0147	5649000000-N	1515	RECONNECT WATER METER	7 EA		
0148	5666000000-N	1515	FIRE HYDRANT	2 EA		
0149	5672000000-N	1515	RELOCATE FIRE HYDRANT	3 EA		
0150	5673000000-E	1515	FIRE HYDRANT LEG	52 LF		
0151	5684800000-E	1515	10" LINE STOP WITH BYPASS	1 EA		
0152	5686500000-E	1515	WATER SERVICE LINE	1,502 LF		

County: TRANSYLVANIA

Line #	Item Number	Sec #	Description	Quantity	Unit Cost	Amount
0153	5689000000-E	1515	GENERIC UTILITY ITEM 4" CHECK VALVE	1 EA		
0154	5691100000-E	1520	4" SANITARY GRAVITY SEWER	24 LF		
0155	5691300000-E	1520	8" SANITARY GRAVITY SEWER	337 LF		
0156	5709200000-E	1520	4" FORCE MAIN SEWER	34 LF		
0157	5709300000-E	1520	6" FORCE MAIN SEWER	251 LF		
0158	5768000000-N	1520	SANITARY SEWER CLEAN-OUT	1 EA		
0159	5768500000-E	1520	SEWER SERVICE LINE	10 LF		
0160	5769000000-E	1520	DUCTILE IRON SEWER PIPE FITTINGS	1,275 LB		
0161	5775000000-E	1525	4' DIA UTILITY MANHOLE	4 EA		
0162	5781000000-E	1525	UTILITY MANHOLE WALL 4' DIA	9 LF		
0163	5800000000-E	1530	ABANDON 6" UTILITY PIPE	552 LF		
0164	5801000000-E	1530	ABANDON 8" UTILITY PIPE	509 LF		
0165	5802000000-E	1530	ABANDON 10" UTILITY PIPE	3,656 LF		
0166	5815500000-N	1530	REMOVE FIRE HYDRANT	1 EA		
0167	5816000000-N	1530	ABANDON UTILITY MANHOLE	1 EA		
0168	5835000000-E	1540	*** ENCASEMENT PIPE (10")	10 LF		
0169	5835400000-E	1540	6" ENCASEMENT PIPE	10 LF		

County: TRANSYLVANIA

Line #	Item Number	Sec #	Description	Quantity	Unit Cost	Amount
0170	5836000000-E	1540	24" ENCASEMENT PIPE	402 LF		
0171	5872600000-E	1550	DIRECTIONAL DRILLING OF *** (12")	328 LF		
0172	5918000000-N	SP	GENERIC UTILITY ITEM UTILITY COORDINATION	3,250 HR		
0173	6000000000-E	1605	TEMPORARY SILT FENCE	11,860 LF		
0174	6006000000-E	1610	STONE FOR EROSION CONTROL, CLASS A	560 TON		
0175	6009000000-E	1610	STONE FOR EROSION CONTROL, CLASS B	515 TON		
0176	6012000000-E	1610	SEDIMENT CONTROL STONE	900 TON		
0177	6015000000-E	1615	TEMPORARY MULCHING	8.5 ACR		
0178	6018000000-E	1620	SEED FOR TEMPORARY SEEDING	500 LB		
0179	6021000000-E	1620	FERTILIZER FOR TEMPORARY SEEDING	2.5 TON		
0180	6024000000-E	1622	TEMPORARY SLOPE DRAINS	200 LF		
0181	6029000000-E	SP	SAFETY FENCE	560 LF		
0182	6030000000-E	1630	SILT EXCAVATION	1,150 CY		
0183	6036000000-E	1631	MATTING FOR EROSION CONTROL	20,000 SY		
0184	6037000000-E	SP	COIR FIBER MAT	100 SY		
0185	6042000000-E	1632	1/4" HARDWARE CLOTH	2,420 LF		
0186	6070000000-N	1639	SPECIAL STILLING BASINS	3 EA		

County: TRANSYLVANIA

Line #	Item Number	Sec #	Description	Quantity	Unit Cost	Amount
0187	6071012000-E	SP	COIR FIBER WATTLE	450 LF		
0188	6071020000-E	SP	POLYACRYLAMIDE (PAM)	140 LB		
0189	6071030000-E	1640	COIR FIBER BAFFLE	80 LF		
0190	6084000000-E	1660	SEEDING & MULCHING	5 ACR		
0191	6087000000-E	1660	MOWING	3 ACR		
0192	6090000000-E	1661	SEED FOR REPAIR SEEDING	100 LB		
0193	6093000000-E	1661	FERTILIZER FOR REPAIR SEEDING	0.25 TON		
0194	6096000000-E	1662	SEED FOR SUPPLEMENTAL SEEDING	200 LB		
0195	6108000000-E	1665	FERTILIZER TOPDRESSING	6 TON		
0196	6111000000-E	SP	IMPERVIOUS DIKE	315 LF		
0197	6114500000-N	1667	SPECIALIZED HAND MOWING	10 MHR		
0198	6114800000-N	SP	MANUAL LITTER REMOVAL	5 MHR		
0199	6114900000-E	SP	LITTER DISPOSAL	1 TON		
0200	6117000000-N	SP	RESPONSE FOR EROSION CONTROL	75 EA		
0201	6117500000-N	SP	CONCRETE WASHOUT STRUCTURE	6 EA		
0202	6123000000-E	1670	REFORESTATION	0.1 ACR		
0203	6132000000-N	SP	GENERIC EROSION CONTROL ITEM FABRIC INSERT INLET PROTECTION DEVICE	50 EA		

County: TRANSYLVANIA

Line #	Item Number	Sec #	Description	Quantity	Unit Cost	Amount
0204	6132000000-N	SP	GENERIC EROSION CONTROL ITEM FABRIC INSERT INLET PROTECTION DEVICE CLEANOUT	150 EA		
0205	6210000000-N	1670	ACER RUBRUM, RED MAPLE, ACER RUBRUM RED MAPLE ('BOWHALL', 10'-12')	2 EA		
0206	6245000000-N	1670	CERCIS CANADENSIS, REDBUD, (5' MIN.)	3 EA		
0207	6265000000-N	1670	CORNUS KOUSA, KOUSA DOGWOOD, CORNUS KOUSA KOUSA DOGWOOD (JAPANESE DOGWOOD, 5' MIN)	6 EA		
0208	6340000000-N	1670	HEMEROCALLIS, DAYLILY HEMEROCALLIS DAYLILLY ('HAPPY RETURNS' DWARF DAYLILY 1 GAL)	45 EA		
0209	6385000000-N	1670	ILEX VERTICILLATA, WINTERBERRY ILEX VERTICILLATA ('JIM DANDY' WINTERBERRY, 7 GAL)	4 EA		
0210	6385000000-N	1670	ILEX VERTICILLATA, WINTERBERRY ILEX VERTICILLATA ('RED SPRITE' WINTERBERRY, 3 GAL)	18 EA		
0211	6400000000-N	1670	ITEA VIRGINICA, VIRGINIA SWEETSPIRE, ITEA VIRGINICA ('SPRICH' LITTLE HENRY SWEETSPIRE, 3 GAL)	106 EA		
0212	6500000000-N	1670	NYSSA SYLVATICA, BLACK GUM, NYSSA SYLVATICA TUPELO, BLACK GUM (2.5-3 GAL)	3 EA		
0213	6640000000-N	1670	GENERIC PLANTING ITEM AMELANCHIER CANADENSIS SHADBLOW SERVICEBERRY (6')	4 EA		
0214	6640000000-N	1670	GENERIC PLANTING ITEM ARONIA MELANOCARPA 'UCONNAM165' MOUND CHOKEBERRY (2 GAL)	34 EA		
0215	6640000000-N	1670	GENERIC PLANTING ITEM BAPTISIA HYBRID FALSE INDIGO (1 GAL)	21 EA		
0216	6640000000-N	1670	GENERIC PLANTING ITEM CALAMAGROSTIS X ACUTIFLORA 'KARL FOERSTER' FOERSTER'S FEATHER REED GRASS (3 GAL)	18 EA		
0217	6640000000-N	1670	GENERIC PLANTING ITEM CAREX AMPHIBOLA CREEK SEDGE (3.25")	66 EA		

County: TRANSYLVANIA

Line #	Item Number	Sec #	Description	Quantity	Unit Cost	Amount
0218	6640000000-N	1670	GENERIC PLANTING ITEM CAREX FLACCA 'BLUE ZINGER' BLUE ZINGER SEDGE (3.25")	36 EA		
0219	6640000000-N	1670	GENERIC PLANTING ITEM CARPINUS CAROLINIANA 'JFS-KW6' NATIVE FLAME AMERICAN HORNBEAM (5' MIN)	4 EA		
0220	6640000000-N	1670	GENERIC PLANTING ITEM CHIONANTHUS VIRGINICUS WHITE FRINGE TREE (5' MIN)	3 EA		
0221	6640000000-N	1670	GENERIC PLANTING ITEM CORNUS X 'RUTGAN' STELLER PINK DOGWOOD (5' MIN)	3 EA		
0222	6640000000-N	1670	GENERIC PLANTING ITEM CRATAEGUS VIRIDIS 'WINTER KING' HAWTHORN (2-2.5" CAL)	3 EA		
0223	6640000000-N	1670	GENERIC PLANTING ITEM DESCHAMPSIA CAESPITOSA 'GOLDTAU' GOLDEN DEW TUFTED HAIR GRASS (1 GAL)	76 EA		
0224	6640000000-N	1670	GENERIC PLANTING ITEM DEUTZIA GRACILIS 'MINCREAM' CREME FRAICHE DEUTZIA (3 GAL)	44 EA		
0225	6640000000-N	1670	GENERIC PLANTING ITEM FOTHERGILLA GARDENII 'BLUE SHADOW' FOTHERGILLA (3 GAL)	19 EA		
0226	6640000000-N	1670	GENERIC PLANTING ITEM HELIANTHUS ANNUUS 'LOW DOWN' SUNFLOWER (1 GAL)	60 EA		
0227	6640000000-N	1670	GENERIC PLANTING ITEM HYDRANGEA ARBORESCENS 'NCHA5' INVINCIBELLE WEE WHITE (2 GAL)	71 EA		
0228	6640000000-N	1670	GENERIC PLANTING ITEM HYDRANGEA PANICULATA 'LIMELIGHT' HARDY HYDRANGEA (5 GAL)	10 EA		
0229	6640000000-N	1670	GENERIC PLANTING ITEM HYDRANGEA SERRATA 'MAKD' TINY TUFF STUFF MOUNTAIN HYDRANGEA (2 GAL)	100 EA		
0230	6640000000-N	1670	GENERIC PLANTING ITEM JUNIPERUS SQUAMATA 'BLUE STAR' BLUE STAR JUNIPER (3 GAL)	23 EA		

County: TRANSYLVANIA

Line #	Item Number	Sec #	Description	Quantity	Unit Cost	Amount
0231	6640000000-N	1670	GENERIC PLANTING ITEM MONARDA DIDYMA 'PARDON MY PURPLE' BEE BALM (1 GAL)	29 EA		
0232	6640000000-N	1670	GENERIC PLANTING ITEM NEPETA X FAASSENII 'WALKER'S LOW' CATMINT (1 GAL)	74 EA		
0233	6640000000-N	1670	GENERIC PLANTING ITEM PHLOX HYBRIDA 'PHL091601' PAPARAZZI LEVINE CREEPING PHLOX (1 GAL)	18 EA		
0234	6640000000-N	1670	GENERIC PLANTING ITEM PHLOX HYBRIDA 'PPPHL07301' PAPARAZZI ANGELINA CREEPING PHLOX (1 GAL)	24 EA		
0235	6640000000-N	1670	GENERIC PLANTING ITEM PICEA ABIES 'CUPRESSINA' COLUMNAR NORWAY SPRUCE (10'- 12')	6 EA		
0236	6640000000-N	1670	GENERIC PLANTING ITEM PICEA GLAUCA 'PENDULA' WEEPING WHITE SPRUCE (8' MIN)	3 EA		
0237	6640000000-N	1670	GENERIC PLANTING ITEM PINUS MUGO 'SLOWMOUND' SLOWMOUND MUGO PINE (3 GAL)	37 EA		
0238	6640000000-N	1670	GENERIC PLANTING ITEM PRUNUS LAUROCERASUS 'MOUNT VERNON' ENGLISH LAUREL (3 GAL)	27 EA		
0239	6640000000-N	1670	GENERIC PLANTING ITEM QUERCUS X WAREI 'NADLER' KINDRED SPIRIT OAK (10-12")	9 EA		
0240	6640000000-N	1670	GENERIC PLANTING ITEM RHODODENDRON 'CHIONOIDES' RHODODENDRON (3 GAL)	13 EA		
0241	6640000000-N	1670	GENERIC PLANTING ITEM RHODODENDRON 'ROBLES' PP22762 AUTUMN LILAC ENCORE AZALEA (3 GAL)	14 EA		
0242	6640000000-N	1670	GENERIC PLANTING ITEM RHODODENDRON 'ROSEUM ELEGANS' RHODODENDRON (5-7 GAL)	5 EA		
0243	6640000000-N	1670	GENERIC PLANTING ITEM ROSA X 'NOATRAUM' FLOWER CARPET PINK GROUND COVER ROSE (3 GAL)	97 EA		

County: TRANSYLVANIA

Line #	Item Number	Sec #	Description	Quantity	Unit Cost	Amount
0244	6640000000-N	1670	GENERIC PLANTING ITEM SALVIA NEMOROSA 'CARADONNA' MEADOW SAGE (1 GAL)	20 EA		
0245	6640000000-N	1670	GENERIC PLANTING ITEM SPIRAEA JAPONICA 'YAN' USPP 21615 DOUBLE PLAY GOLD SPIREA (3 GAL)	85 EA		
0246	6640000000-N	1670	GENERIC PLANTING ITEM SPOROBOLUS HETEROLEPIS PRAIRIE DROPSEED (1 GAL)	85 EA		
0247	6640000000-N	1670	GENERIC PLANTING ITEM SPOROBOLUS HETEROLEPIS 'TARA' PRAIRIE DROPSEED (1 GAL)	242 EA		
0248	6640000000-N	1670	GENERIC PLANTING ITEM TAXUS X MEDIA 'EVERLOW' SPREADING YEW (3 GAL)	16 EA		
0249	6640000000-N	1670	GENERIC PLANTING ITEM THUJA OCCIDENTALIS 'TECHNY' ARBORVITAE (6' MIN)	7 EA		
0250	6640000000-N	1670	GENERIC PLANTING ITEM VIBURNUM X PRAGENSE PRAGUE VIBURNUM (3'X3' MIN)	5 EA		
0251	6645000000-N	SP	GENERIC PLANTING ITEM CONCRETE TUBE FOR POST HOLES (8" DIAMETER X 48" DEPTH)	24 EA		
0252	6645000000-N	SP	GENERIC PLANTING ITEM LANDSCAPE LIGHTS	38 EA		
0253	6645000000-N	SP	GENERIC PLANTING ITEM LOW VOLTAGE TRANSFORMER	2 EA		
0254	6645000000-N	SP	GENERIC PLANTING ITEM MEDIUM BOULDERS	5 EA		
0255	6645000000-N	SP	GENERIC PLANTING ITEM PHOTOCELL	2 EA		
0256	6645000000-N	SP	GENERIC PLANTING ITEM SMALL BOULDERS	6 EA		
0257	6645000000-N	SP	GENERIC PLANTING ITEM TIMBER FENCE SECTION INCLUDING FASTENERS AND STAIN	12 EA		
0258	6676000000-E	SP	GENERIC PLANTING ITEM SODDING	38,352 SF		

County: TRANSYLVANIA

Line #	Item Number	Sec #	Description	Quantity	Unit Cost	Amount
0259	6677000000-E	SP	GENERIC PLANTING ITEM FLAGSTONE	4.5 TON		
0260	6680000000-E	SP	GENERIC PLANTING ITEM MULCH	140 CY		
0261	6680000000-E	SP	GENERIC PLANTING ITEM RIVER ROCK	14 CY		
0262	6680000000-E	SP	GENERIC PLANTING ITEM SAND FOR SETTING BED	2.8 CY		
0263	6680000000-E	SP	GENERIC PLANTING ITEM SOIL AMENDMENT	95 CY		
0264	6690000000-E	SP	GENERIC PLANTING ITEM CONDUIT 1-1/2" PVC	690 LF		
0265	6690000000-E	SP	GENERIC PLANTING ITEM CONDUIT 1" PVC	200 LF		
0266	6690000000-E	SP	GENERIC PLANTING ITEM LANDSCAPE EDGING	950 LF		
0267	7048500000-E	1705	PEDESTRIAN SIGNAL HEAD (16", 1 SECTION W/COUNTDOWN)	10 EA		
0268	7060000000-E	1705	SIGNAL CABLE	15,910 LF		
0269	7120000000-E	1705	VEHICLE SIGNAL HEAD (12", 3 SECTION)	42 EA		
0270	7132000000-E	1705	VEHICLE SIGNAL HEAD (12", 4 SECTION)	11 EA		
0271	7144000000-E	1705	VEHICLE SIGNAL HEAD (12", 5 SECTION)	2 EA		
0272	7229000000-N	SP	APS DETECTOR STATION	12 EA		
0273	7230000000-N	SP	CENTRAL CONTROL UNIT APS DETECTOR STATION	2 EA		
0274	7264000000-E	1710	MESSENGER CABLE (3/8")	3,128 LF		
0275	7288000000-E	1715	PAVED TRENCHING (***** (1, 2")	1,061 LF		

County: TRANSYLVANIA

Line #	Item Number	Sec #	Description	Quantity	Unit Cost	Amount
0276	7288000000-E	1715	PAVED TRENCHING (*****) (2, 2")	238 LF		
0277	7288000000-E	1715	PAVED TRENCHING (*****) (3, 2")	2 LF		
0278	7288000000-E	1715	PAVED TRENCHING (*****) (6, 2")	11 LF		
0279	7300000000-E	1715	UNPAVED TRENCHING (*****) (1, 2")	148 LF		
0280	7300000000-E	1715	UNPAVED TRENCHING (*****) (2, 2")	13 LF		
0281	7301000000-E	1715	DIRECTIONAL DRILL (*****) (2, 2")	230 LF		
0282	7324000000-N	1716	JUNCTION BOX (STANDARD SIZE)	18 EA		
0283	7348000000-N	1716	JUNCTION BOX (OVER-SIZED, HEAVY DUTY)	3 EA		
0284	7360000000-N	1720	WOOD POLE	14 EA		
0285	7372000000-N	1721	GUY ASSEMBLY	28 EA		
0286	7408000000-E	1722	1" RISER WITH WEATHERHEAD	3 EA		
0287	7420000000-E	1722	2" RISER WITH WEATHERHEAD	10 EA		
0288	7444000000-E	1725	INDUCTIVE LOOP SAWCUT	1,226 LF		
0289	7456000000-E	1726	LEAD-IN CABLE (*****) (14-2)	10,720 LF		
0290	7575200000-N	SP	GPS UNIT	3 EA		
0291	7576000000-N	SP	METAL STRAIN SIGNAL POLE	4 EA		
0292	7613000000-N	SP	SOIL TEST	4 EA		

County: TRANSYLVANIA

Line #	Item Number	Sec #	Description	Quantity	Unit Cost	Amount
0293	7614100000-E	SP	DRILLED PIER FOUNDATION	40 CY		
0294	7636000000-N	1745	SIGN FOR SIGNALS	23 EA		
0295	7642100000-N	1743	TYPE I POST WITH FOUNDATION	2 EA		
0296	7642200000-N	1743	TYPE II PEDESTAL WITH FOUNDATION	36 EA		
0297	7684000000-N	1750	SIGNAL CABINET FOUNDATION	1 EA		
0298	7696000000-N	1751	CONTROLLERS WITH CABINET (***** (TYPE 2070LX W/ QFREE MAXTIME, BASE MOUNTED)	1 EA		
0299	7696000000-N	1751	CONTROLLERS WITH CABINET (***** (TYPE 2070LX W/ QFREE MAXTIME, POLE MOUNTED)	3 EA		
0300	7744000000-N	1751	DETECTOR CARD (TYPE 170)	10 EA		
0301	7901000000-N	1753	CABINET BASE EXTENDER	1 EA		
0302	7972000000-N	SP	METAL POLE REMOVAL	8 EA		
0303	7980000000-N	SP	GENERIC SIGNAL ITEM MICROWAVE VEHICLE DETECTION SYSTEM (MULTIPLE ZONES)	14 EA		
0304	7980000000-N	SP	GENERIC SIGNAL ITEM PROTECTIVE COATING FOR PUSHBUTTON POST (BLACK)	2 EA		
0305	7980000000-N	SP	GENERIC SIGNAL ITEM PROTECTIVE COATING FOR SIGNAL PEDESTAL (BLACK)	36 EA		
0306	7980000000-N	SP	GENERIC SIGNAL ITEM PROTECTIVE COATING FOR STRAIN POLE (BLACK)	4 EA		
0307	7980000000-N	SP	GENERIC SIGNAL ITEM RECTANGULAR RAPID FLASHING BEACON ASSEMBLY	28 EA		

County: TRANSYLVANIA

Line #	Item Number	Sec #	Description	Quantity	Unit Cost	Amount
0308	7980000000-N	SP	GENERIC SIGNAL ITEM TYPE 2070LX CONTROLLER	1 EA		
***** BEGIN SCHEDULE AA ***** ***** (2 ALTERNATES) *****						
0309 AA1	1491000000-E	610	ASPHALT CONC BASE COURSE, TYPE B25.0C	3,810 TON		
0310 AA1	1575000000-E	620	ASPHALT BINDER FOR PLANT MIX	1,240 TON		
*** OR ***						
0311 AA2	1121000000-E	520	AGGREGATE BASE COURSE	1,113 TON		
0312 AA2	1491000000-E	610	ASPHALT CONC BASE COURSE, TYPE B25.0C	2,850 TON		
0313 AA2	1575000000-E	620	ASPHALT BINDER FOR PLANT MIX	1,195 TON		
***** END SCHEDULE AA *****						
CULVERT ITEMS						
0314	8126000000-N	414	CULVERT EXCAVATION, STA ***** (17+47.31 -Y2-)	Lump Sum	L.S.	
0315	8133000000-E	414	FOUNDATION CONDITIONING MATERIAL, BOX CULVERT	67 TON		
0316	8196000000-E	420	CLASS A CONCRETE (CULVERT)	115.2 CY		
0317	8245000000-E	425	REINFORCING STEEL (CULVERT)	14,161 LB		
WALL ITEMS						
0318	8801000000-E	SP	MSE RETAINING WALL NO **** (1)	310 SF		
0319	8801000000-E	SP	MSE RETAINING WALL NO **** (2)	1,300 SF		
0320	8801000000-E	SP	MSE RETAINING WALL NO **** (3)	430 SF		
0321	8802014000-E	SP	SOLDIER PILE RETAINING WALLS	870 SF		
0322	8847000000-E	SP	GENERIC RETAINING WALL ITEM NATURAL STONE VENEER	870 SF		

County: TRANSYLVANIA

Line #	Item Number	Sec #	Description	Quantity	Unit Cost	Amount
1147/Oct16/Q335540.13/D1580609386000/E322						Total Amount Of Bid For Entire Project :
