

TIP PROJECT: I-5972

CONTRACT: C204873

**STATE OF NORTH CAROLINA  
DEPARTMENT OF TRANSPORTATION**

**PAVEMENT MARKING PLAN  
JOHNSTON COUNTY**

**LOCATION: I-95 AND US 70 BUSINESS, UPGRADE INTERCHANGE FROM  
OUTLET CENTER DR. TO WEST OF YELVERTON GROVE RD.**

PROJECT REFERENCE NO. <b>I - 5972</b>	SHEET NO. <b>PMP - 1</b>
APPROVED: 9/19/2023	
SEAL	
<b>DOCUMENT NOT CONSIDERED FINAL UNLESS ALL SIGNATURES COMPLETED</b>	

**ROADWAY STANDARD DRAWING**

THE FOLLOWING ROADWAY STANDARDS AS APPEAR IN "ROADWAY STANDARD DRAWINGS" - PROJECT SERVICES UNIT - N.C. DEPARTMENT OF TRANSPORTATION - RALEIGH, N.C., DATED JANUARY 2018 ARE APPLICABLE TO THIS PROJECT AND BY REFERENCE HEREBY ARE CONSIDERED A PART OF THESE PLANS:

STD. NO.	TITLE
1205.01	PAVEMENT MARKINGS - LINE TYPES AND OFFSETS
1205.02	PAVEMENT MARKINGS - TWO-LANE AND MULTI-LANE ROADWAYS
1205.03	PAVEMENT MARKINGS - EXIT AND ENTRANCE RAMP
1205.04	PAVEMENT MARKINGS - INTERSECTIONS
1205.05	PAVEMENT MARKINGS - TURN LANES
1205.06	PAVEMENT MARKINGS - LANE DROPS
1205.07	PAVEMENT MARKINGS - PEDESTRIAN CROSSWALK
1205.08	PAVEMENT MARKINGS - SYMBOLS AND WORD MESSAGES
1205.09	PAVEMENT MARKINGS - PAINTED ISLANDS
1205.13	PAVEMENT MARKINGS - LANE REDUCTIONS
1250.01	RAISED PAVEMENT MARKERS - INSTALLATION SPACING
1251.01	RAISED PAVEMENT MARKERS - PERMANENT AND TEMPORARY
1253.01	RAISED PAVEMENT MARKERS - SNOWPLOWABLE
1261.01	GUARDRAIL AND BARRIER DELINEATORS- INSTALLATION SPACING
1261.02	GUARDRAIL AND BARRIER DELINEATORS - TYPES AND MOUNTING
1262.01	GUARDRAIL END DELINEATION

**INDEX**

SHEET NO.	DESCRIPTION
PMP-1	PAVEMENT MARKING PLAN TITLE SHEET
PMP-2 THRU PMP-2A	DETAILS TO BE USED IN LIEU OF 2018 STANDARD DETAILS
PMP-2B	CURB RAMP INFORMATION
PMP-3 THRU PMP-8	PAVEMENT MARKING DETAILS

**GENERAL NOTES**

THE FOLLOWING GENERAL NOTES APPLY AT ALL TIMES FOR THE DURATION OF THE CONSTRUCTION PROJECT, EXCEPT WHEN OTHERWISE NOTED IN THE PLAN, OR DIRECTED BY THE ENGINEER.

- A) INSTALL PAVEMENT MARKINGS AND PAVEMENT MARKERS ON THE FINAL SURFACE AS FOLLOWS:

ROAD NAME	MARKING	MARKER
I-95,US-70	THERMOPLASTIC	NON-CAST IRON SNOWPLOWABLE
-Y2- AND -Y3-	THERMOPLASTIC	NONE
CONCRETE SURFACES	COLD APPLIED (TYPE III)	PERMANENT RAISED

- B) TIE PROPOSED PAVEMENT MARKING LINES TO EXISTING PAVEMENT MARKING LINES.
- C) REMOVE/REPLACE ANY CONFLICTING/DAMAGED PAVEMENT MARKINGS AND MARKERS.
- D) STOP BAR LOCATION AT NON-SIGNALIZED INTERSECTIONS MAY BE ADJUSTED AS DIRECTED BY THE ENGINEER.
- E) REMOVE ALL RESIDUE AND SURFACE LAITANCE BY ACCEPTABLE METHODS ON CONCRETE BRIDGE DECKS PRIOR TO PLACING COLD APPLIED PLASTIC, TYPE III PAVEMENT MARKING MATERIAL.
- F) UNLESS OTHERWISE SPECIFIED, HEATED-IN-PLACE THERMOPLASTIC MAY BE USED IN LIEU OF EXTRUDED THERMOPLASTIC FOR STOP BARS, SYMBOLS, CHARACTERS AND DIAGONALS. IF HEATED-IN-PLACE IS USED, IT SHALL BE PAID FOR USING THE EXTRUDED THERMOPLASTIC PAY ITEM.

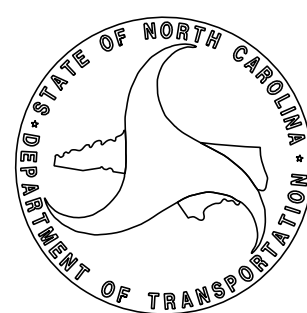

**PLAN PREPARED FOR: N.C.D.O.T. SIGNING AND DELINEATION UNIT**

R. B. ROACH, P.E., CPM	STATE SIGNING & DELINEATION ENGINEER
MITCH EATON, P.E.	SIGNING & DELINEATION REGIONAL ENGINEER

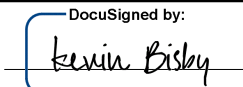

**RK&K**  
P: (919) 878-9660  
8601 Six Forks Road, Forum 1, Suite 700  
Raleigh, North Carolina 27615-3960  
NC License No. F-0112

Responsive People | Creative Solutions

PROJECT I - 5972	SHEET NO. PMP - 2
APPROVED:  <small>DocuSigned by: Kevin W. B. Esby 800802028912474</small> DATE: 9/19/2023	
SEAL	
	
<b>DOCUMENT NOT CONSIDERED FINAL UNLESS ALL SIGNATURES COMPLETED</b>	

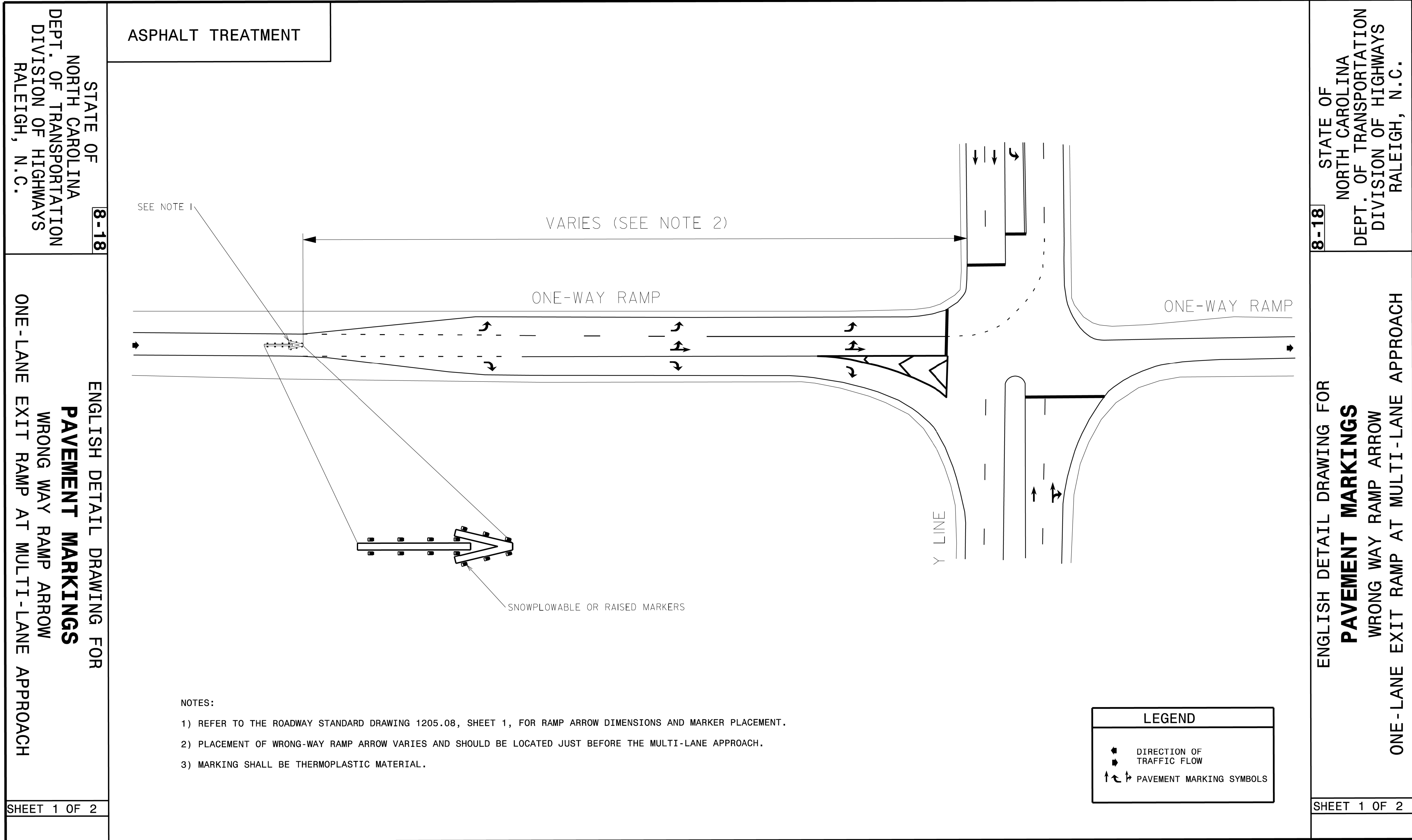

STATE OF NORTH CAROLINA  
 DEPT. OF TRANSPORTATION  
 DIVISION OF HIGHWAYS  
 RALEIGH, N.C.

**8-18**  
 ENGLISH DETAIL DRAWING FOR  
**PAVEMENT MARKINGS**  
 WRONG WAY RAMP ARROW  
 ONE-LANE EXIT RAMP AT MULTI-LANE APPROACH

SHEET 1 OF 2

- NOTES:
- 1) REFER TO THE ROADWAY STANDARD DRAWING 1205.08, SHEET 1, FOR RAMP ARROW DIMENSIONS AND MARKER PLACEMENT.
  - 2) PLACEMENT OF WRONG-WAY RAMP ARROW VARIES AND SHOULD BE LOCATED JUST BEFORE THE MULTI-LANE APPROACH.
  - 3) MARKING SHALL BE THERMOPLASTIC MATERIAL.

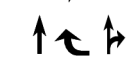
LEGEND	
	DIRECTION OF TRAFFIC FLOW
	PAVEMENT MARKING SYMBOLS

**8-18**  
 STATE OF NORTH CAROLINA  
 DEPT. OF TRANSPORTATION  
 DIVISION OF HIGHWAYS  
 RALEIGH, N.C.

ENGLISH DETAIL DRAWING FOR  
**PAVEMENT MARKINGS**  
 WRONG WAY RAMP ARROW  
 ONE-LANE EXIT RAMP AT MULTI-LANE APPROACH

SHEET 1 OF 2

9/19/2023  
 P:\5972\1818\_PSH02.dgn

**RKK**  
 P: (919) 678-8600  
 8601 Six Forks Road Forum 1 Suite 700 | Raleigh, North Carolina 27615  
 NC License No. F-0112  
 Responsive People | Creative Solutions

PAVEMENT MARKING DETAIL

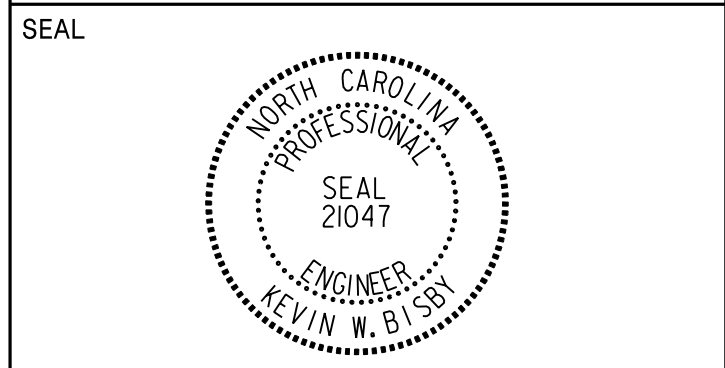

**DOCUMENT NOT CONSIDERED FINAL  
 UNLESS ALL SIGNATURES COMPLETED**

TIP NO.	SHEET NO.
DocuSigned by: <i>Matthew V. Springer</i>	
APPROVED:	8/13/2019
DATE:	6620190808584403...
SEAL	

STATE OF NORTH CAROLINA DEPT. OF TRANSPORTATION DIVISION OF HIGHWAYS RALEIGH, N.C.	<b>TWO-LANE, TWO-WAY ROADWAY</b>	<p>* STOP BAR, SEE NOTE 1        * WHITE 2'-6"/SP MINI-SKIP LINE, SEE NOTE 3        10' TYP.</p>	<b>TWO-LANE, TWO-WAY ROADWAY WITH TWO-WAY LEFT TURN LANE</b>	<p>* STOP BAR, SEE NOTE 1        * WHITE 2'-6"/SP MINI-SKIP LINE, SEE NOTE 3        10' TYP. 160'</p>	STATE OF NORTH CAROLINA DEPT. OF TRANSPORTATION DIVISION OF HIGHWAYS RALEIGH, N.C.						
	<b>UNDIVIDED MULTI-LANE ROADWAY</b>	<p>* STOP BAR, SEE NOTE 1        * WHITE 2'-6"/SP MINI-SKIP LINE, SEE NOTE 3        150' 60' 10' TYP.        * WHITE 2'-6"/SP MINI-SKIP LINES, SEE NOTE 2</p>	<b>DIVIDED MULTI-LANE ROADWAY WITH TURN BAY</b>	<p>* STOP BAR, SEE NOTE 1        * WHITE 2'-6"/SP MINI-SKIP LINE, SEE NOTE 3        * YELLOW 2'-6"/SP MINI-SKIP LINE        MEDIAN        150' 60'        CONTINUE EDGE LINE AROUND MEDIAN        WHITE 2'-6"/SP MINI-SKIP LINE        REFER TO STD. 1205.05 FOR TURN LANE MARKING GUIDANCE</p>							
	<b>DIVIDED MULTI-LANE ROADWAY WITH WIDE MEDIAN CROSSOVER</b>	<p>* STOP BAR, SEE NOTE 1        * WHITE 2'-6"/SP MINI-SKIP LINE, SEE NOTE 3        CONTINUE EDGE LINE AROUND MEDIAN        YELLOW 2'-6"/SP MINI-SKIP LINES        MEDIAN        &gt;30' REF.        150' 60'</p> <p>USE DOUBLE YELLOW CENTER LINE AND ARROW SYMBOLS IN MEDIAN CROSSOVER WHEN WIDTH OF MEDIAN EXCEEDS 30 FT, OTHERWISE THEY ARE NOT REQUIRED.</p>	<p><b>GENERAL NOTES:</b></p> <ol style="list-style-type: none"> <li>1- PLACEMENT OF STOP BARS AT NON-SIGNALIZED INTERSECTIONS IS OPTIONAL AND USED WHERE IT IS IMPORTANT TO INDICATE THE POINT WHICH VEHICLES ARE REQUIRED TO STOP. PLACE STOP BARS NO LESS THAN 4 FEET AND NO MORE THAN 30 FEET FROM THE NEAREST EDGE OF THE INTERSECTING ROADWAY. USE 10 FEET AS THE TYPICAL SETBACK DISTANCE OR AS DIRECTED BY THE ENGINEER.</li> <li>2- MINI-SKIP LANE LINE EXTENSIONS SHOULD BE USED AT INTERSECTIONS THAT HAVE REDUCED VISIBILITY CONDITIONS SUCH AS OFFSET, SKEWED, OR CURVED ROADWAYS.</li> <li>3- MINI-SKIP EDGE LINE EXTENSIONS MAY BE PLACED THROUGH INTERSECTIONS AND MAJOR DRIVEWAYS.</li> <li>4- REFER TO ROADWAY STANDARD DRAWINGS 1205.01, 1205.02, 1205.05, 1205.08 AND 1205.09 FOR ADDITIONAL PAVEMENT MARKING GUIDANCE.</li> </ol> <table border="1" style="width: 100%;"> <tr> <th colspan="2">LEGEND</th> </tr> <tr> <td> STOP SIGN</td> <td> STATIONARY SIGN</td> </tr> <tr> <td> DIRECTION OF TRAFFIC FLOW</td> <td> PAVEMENT MARKING SYMBOLS</td> </tr> <tr> <td>* OPTIONAL</td> <td></td> </tr> </table>			LEGEND		STOP SIGN	STATIONARY SIGN	DIRECTION OF TRAFFIC FLOW	PAVEMENT MARKING SYMBOLS
LEGEND											
STOP SIGN	STATIONARY SIGN										
DIRECTION OF TRAFFIC FLOW	PAVEMENT MARKING SYMBOLS										
* OPTIONAL											



SHEET 2 OF 2  
**1205D04**

SHEET 2 OF 2  
**1205D04**

**REVISED PAVEMENT MARKING  
 ROADWAY STANDARD DRAWING**

U:\13\14\Standards Group\Standards and Drawings\Drawings\Division 12\Find\1205D04\02\_08-15-19.dgn  
 User: jstokes

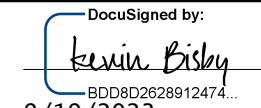
9/19/2023 10:41:23 AM PSH02A.dgn

PROJECT	SHEET NO.
I - 5972	PMP - 2B
APPROVED:  <small>DocuSigned by: Kevin W. Bisby B0C802028912474</small>	
DATE: 9/19/2023	
SEAL	
	
<b>DOCUMENT NOT CONSIDERED FINAL UNLESS ALL SIGNATURES COMPLETED</b>	

CURB RAMP INFORMATION				
CALL-OUT	LOCATION	OFFSET	TYPE	PLAN SHEET
1	-Y1-STA 24+86	38' RT	TYPE 1	6
2	-Y1-STA 25+50	39' RT	TYPE 1	6
3	-Y1-STA 25+99	39' RT	TYPE 1	6
4	-Y1-STA 26+45	39' RT	TYPE 1	6
5	-Y1-STA 26+87	39' RT	TYPE 1	6
6	-Y1-STA 27+27	39' RT	TYPE 1	6
7	-Y1-STA 28+26	43' RT	TYPE 1	6
8	-Y1-STA 28+74	46' RT	TYPE 1	6
9	-Y1-STA 31+06	51' RT	TYPE 1	4
10	-Y1-STA 31+96	43' RT	TYPE 1	4
11	-Y1-STA 42+64	44' RT	TYPE 1	4

9/19/2023  
 P:\5972\11\11\_PSH02B.dgn  
 11:54:55

### PAVEMENT MARKING SCHEDULE

**THERMOPLASTIC LINES (90 MILS)**

- T1 WHITE EDGE LINE (4")
- T2 WHITE SOLID LANE LINE (4")
- T4 3FT.-9FT./SP WHITE MINISKIP (4")
- T5 2FT.-6FT./SP WHITE MINISKIP (4")
- T11 YELLOW SINGLE CENTER (4")
- T12 10FT. YELLOW SKIP (4")
- T13 YELLOW DOUBLE CENTER (4")
- T20 WHITE EDGELINE (6")
- T21 WHITE SOLID LANE LINE (6")
- T22 10FT. WHITE SKIP (6")
- T23 3FT.-9FT. /SP WHITE MINISKIP (6")
- T24 2FT.-6FT./SP WHITE MINISKIP (6")
- T30 YELLOW EDGELINE (6")
- T31 YELLOW SINGLE CENTER (6")
- T32 10 FT. YELLOW SKIP (6")
- T33 YELLOW DOUBLE CENTER (6")
- T42 YELLOW DIAGONAL (8")
- T46 WHITE CROSSWALK LINE (8")
- T50 WHITE GORELINE (12")
- T52 YELLOW DIAGONAL (12")
- T53 WHITE SOLID LANE LINE (12")
- T54 3FT.-9FT./SP WHITE MINISKIP (12")
- T61 WHITE STOPBAR (24")

**COLD APPLIED (TYPE III) LINES**

- C20 WHITE EDGELINE (6")
- C22 10 FT. WHITE SKIP (6")
- C23 3FT.- 9FT./ SP WHITE MINISKIP (6")
- C30 YELLOW EDGELINE (6")

**THERMOPLASTIC SYMBOLS (90 MILS)**

- T70 LEFT TURN ARROW
- T71 RIGHT TURN ARROW
- T72 STRAIGHT ARROW
- T73 COMBO. LEFT/STRAIGHT ARROW
- T74 COMBO. RIGHT /STRAIGHT ARROW
- T79 MERGE ARROW
- T80 WRONG-WAY RAMP ARROW
- T100 ALPHANUMERIC CHAR.
- T103 24" YIELD LINE TRIANGLE

**PAVEMENT MARKERS**

- MB PERMANENT RAISED (CRYSTAL & RED)
- ME SNOWPLOWABLE (YELLOW & YELLOW)
- MF SNOWPLOWABLE (CRYSTAL & RED)

PROJECT SHEET NO.

I-5972 PMP-3

APPROVED: *Kevin Bishy*

DATE: 9/19/2023

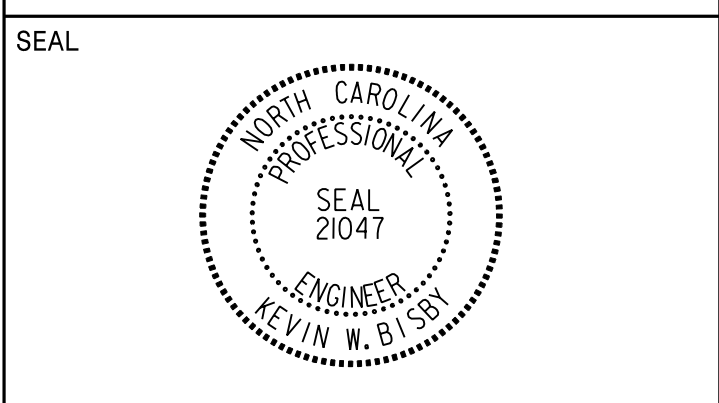

**DOCUMENT NOT CONSIDERED FINAL  
UNLESS ALL SIGNATURES COMPLETED**

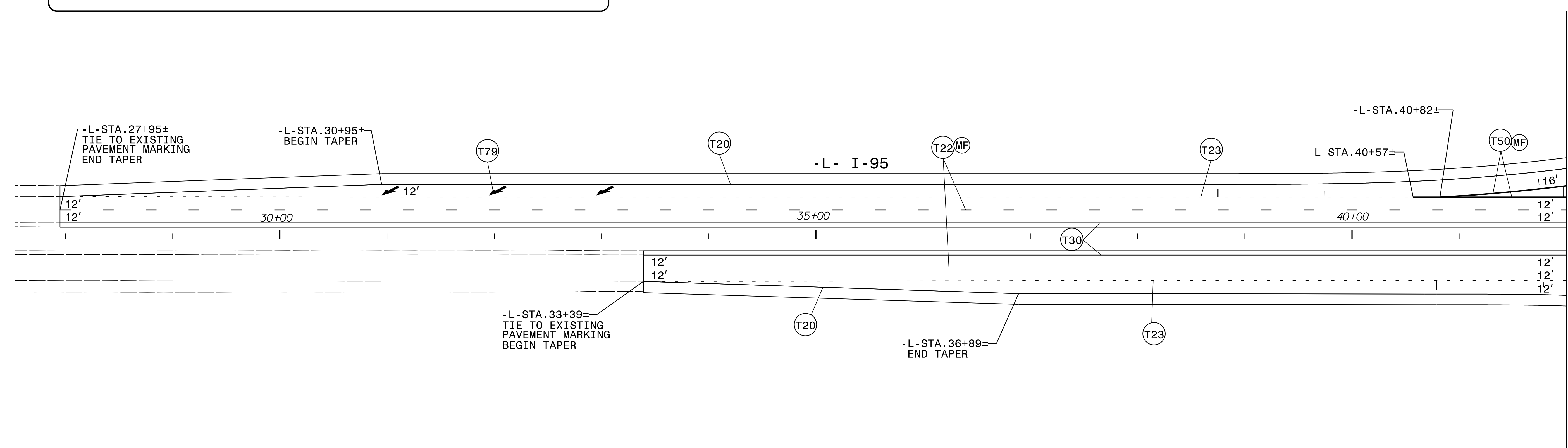
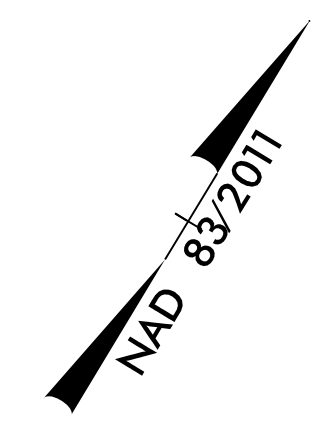

MATCHLINE -L- STA. 42+00 SEE SHEET 4

**NOTE:**  
ALL LANE WIDTHS ARE 12'  
UNLESS OTHERWISE SHOWN.

9/19/2023 10:41:03 AM psh03.dgn

**RKK**  
 P: (919) 578-9500  
 8601 Six Forks Road Forum 1 Suite 700 | Raleigh, North Carolina 27615  
 NC License No. F-0112  
 Responsive People | Creative Solutions

**PAVEMENT MARKING DETAIL**

PAVEMENT MARKING SCHEDULE	
<b>THERMOPLASTIC LINES (90 MILS)</b>	<b>COLD APPLIED (TYPE III) LINES</b>
T1 WHITE EDGE LINE (4")	C20 WHITE EDGELINE (6")
T2 WHITE SOLID LANE LINE (4")	C22 10 FT. WHITE SKIP (6")
T4 3FT.-9FT./SP WHITE MINISKIP (4")	C23 3FT.-9FT./SP WHITE MINISKIP (6")
T5 2FT.-6FT./SP WHITE MINISKIP (4")	C30 YELLOW EDGELINE (6")
T11 YELLOW SINGLE CENTER (4")	<b>THERMOPLASTIC SYMBOLS (90 MILS)</b>
T12 10FT. YELLOW SKIP (4")	T70 LEFT TURN ARROW
T13 YELLOW DOUBLE CENTER (4")	T71 RIGHT TURN ARROW
T20 WHITE EDGELINE (6")	T72 STRAIGHT ARROW
T21 WHITE SOLID LANE LINE (6")	T73 COMBO. LEFT/STRAIGHT ARROW
T22 10FT. WHITE SKIP (6")	T74 COMBO. RIGHT/STRAIGHT ARROW
T23 3FT.-9FT./SP WHITE MINISKIP (6")	T79 MERGE ARROW
T24 2FT.-6FT./SP WHITE MINISKIP (6")	T80 WRONG-WAY RAMP ARROW
T30 YELLOW EDGELINE (6")	T100 ALPHANUMERIC CHAR.
T31 YELLOW SINGLE CENTER (6")	T103 24" YIELD LINE TRIANGLE
T32 10 FT. YELLOW SKIP (6")	
T33 YELLOW DOUBLE CENTER (6")	<b>PAVEMENT MARKERS</b>
T42 YELLOW DIAGONAL (8")	MB PERMANENT RAISED (CRYSTAL & RED)
T46 WHITE CROSSWALK LINE (8")	ME SNOWPLOWABLE (YELLOW & YELLOW)
T50 WHITE GORELINE (12")	MF SNOWPLOWABLE (CRYSTAL & RED)
T52 YELLOW DIAGONAL (12")	
T53 WHITE SOLID LANE LINE (12")	
T54 3FT.-9FT./SP WHITE MINISKIP (12")	
T61 WHITE STOPBAR (24")	

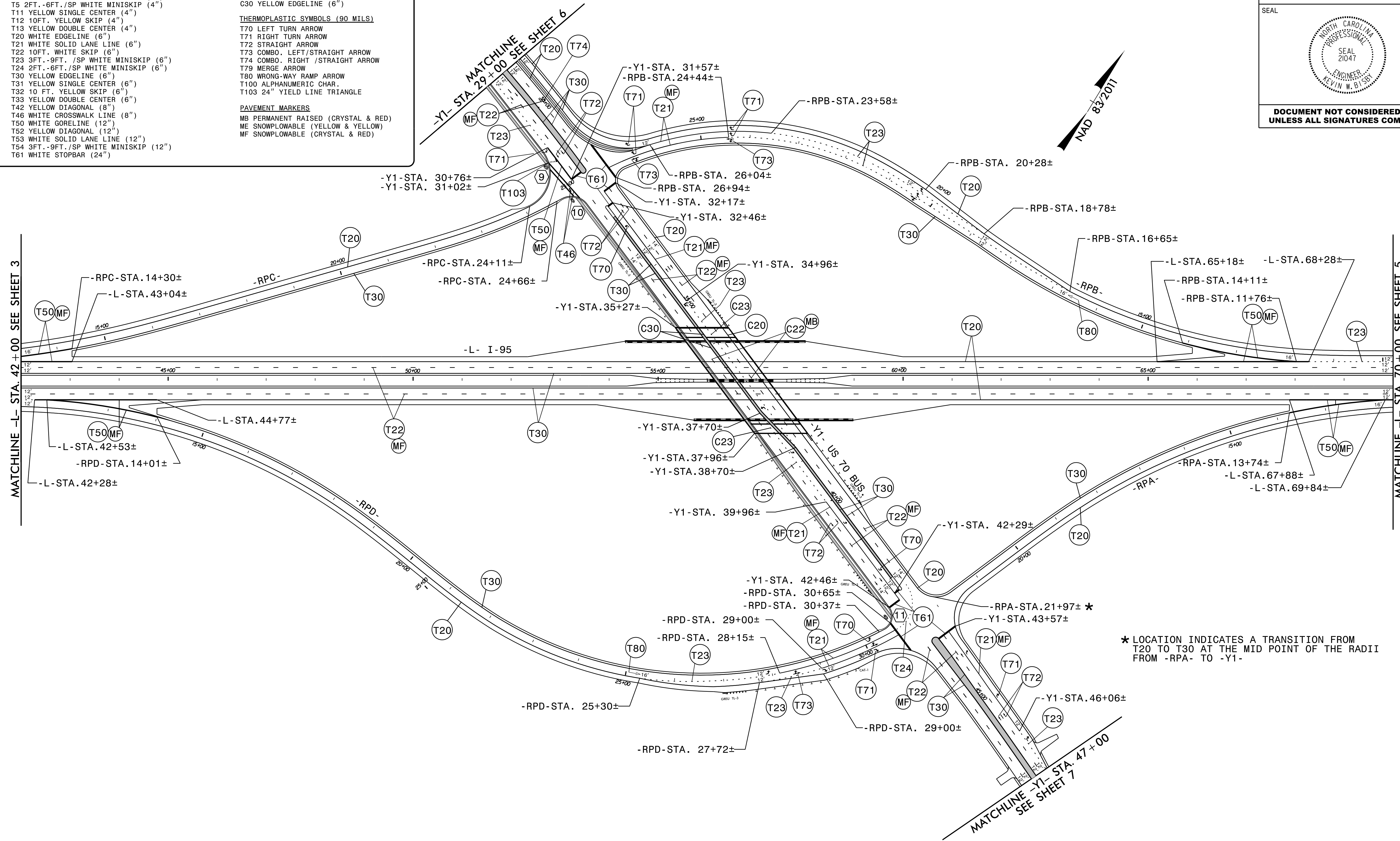

\* LOCATION INDICATES A TRANSITION FROM T20 TO T30 AT THE MID POINT OF THE RADII FROM -RPA- TO -Y1-

- NOTES:
- 1) (#) SEE PMP-2B AND ROADWAY PLAN FOR CURB RAMP INFORMATION.
  - 2) ALL LANE WIDTHS ARE 12' UNLESS OTHERWISE SHOWN.

9/19/2023 10:42:00 AM psh04.dgn

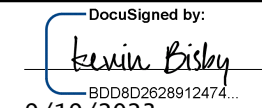
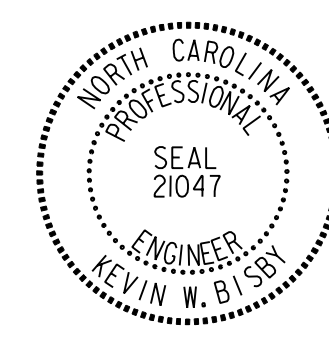
PROJECT	SHEET NO.
I-5972	PMP-5
APPROVED:  <small>DocuSigned by: Kevin W. Bishy 800802028912474</small>	
DATE: 9/19/2023	
SEAL	
	
<b>DOCUMENT NOT CONSIDERED FINAL UNLESS ALL SIGNATURES COMPLETED</b>	

### PAVEMENT MARKING SCHEDULE

**THERMOPLASTIC LINES (90 MILS)**

- T1 WHITE EDGE LINE (4")
- T2 WHITE SOLID LANE LINE (4")
- T4 3FT.-9FT./SP WHITE MINISKIP (4")
- T5 2FT.-6FT./SP WHITE MINISKIP (4")
- T11 YELLOW SINGLE CENTER (4")
- T12 10FT. YELLOW SKIP (4")
- T13 YELLOW DOUBLE CENTER (4")
- T20 WHITE EDGELINE (6")
- T21 WHITE SOLID LANE LINE (6")
- T22 10FT. WHITE SKIP (6")
- T23 3FT.-9FT./SP WHITE MINISKIP (6")
- T24 2FT.-6FT./SP WHITE MINISKIP (6")
- T30 YELLOW EDGELINE (6")
- T31 YELLOW SINGLE CENTER (6")
- T32 10 FT. YELLOW SKIP (6")
- T33 YELLOW DOUBLE CENTER (6")
- T42 YELLOW DIAGONAL (8")
- T46 WHITE CROSSWALK LINE (8")
- T50 WHITE GORELINE (12")
- T52 YELLOW DIAGONAL (12")
- T53 WHITE SOLID LANE LINE (12")
- T54 3FT.-9FT./SP WHITE MINISKIP (12")
- T61 WHITE STOPBAR (24")

**COLD APPLIED (TYPE III) LINES**

- C20 WHITE EDGELINE (6")
- C22 10 FT. WHITE SKIP (6")
- C23 3FT.- 9FT./ SP WHITE MINISKIP (6")
- C30 YELLOW EDGELINE (6")

**THERMOPLASTIC SYMBOLS (90 MILS)**

- T70 LEFT TURN ARROW
- T71 RIGHT TURN ARROW
- T72 STRAIGHT ARROW
- T73 COMBO. LEFT/STRAIGHT ARROW
- T74 COMBO. RIGHT /STRAIGHT ARROW
- T79 MERGE ARROW
- T80 WRONG-WAY RAMP ARROW
- T100 ALPHANUMERIC CHAR.
- T103 24" YIELD LINE TRIANGLE

**PAVEMENT MARKERS**

- MB PERMANENT RAISED (CRYSTAL & RED)
- ME SNOWPLOWABLE (YELLOW & YELLOW)
- MF SNOWPLOWABLE (CRYSTAL & RED)

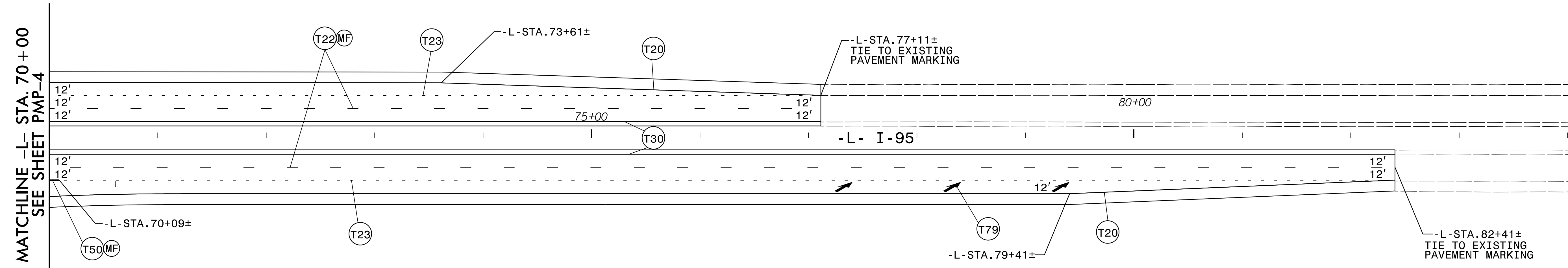
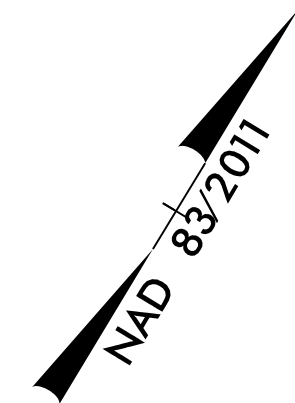



**NOTE:**  
ALL LANE WIDTHS ARE 12'  
UNLESS OTHERWISE SHOWN.

2/19/2023 10:45 AM psh05.dgn

**RKK**  
 P: (919) 578-9500  
 8601 Six Forks Road Forum 1 Suite 700 | Raleigh, North Carolina 27615  
 NC License No. F-0112  
 Responsive People | Creative Solutions

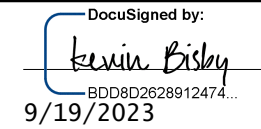
PAVEMENT MARKING DETAIL

PROJECT	SHEET NO.
I-5972	PMP-6
APPROVED:  DocuSigned by: Edwin Bishy 9/19/2023	
DATE: 9/19/2023	
SEAL 	
DOCUMENT NOT CONSIDERED FINAL UNLESS ALL SIGNATURES COMPLETED	

**PAVEMENT MARKING SCHEDULE**

THERMOPLASTIC LINES (90 MILS)

- T1 WHITE EDGE LINE (4")
- T2 WHITE SOLID LANE LINE (4")
- T4 3FT.-9FT./SP WHITE MINISKIP (4")
- T5 2FT.-6FT./SP WHITE MINISKIP (4")
- T11 YELLOW SINGLE CENTER (4")
- T12 10FT. YELLOW SKIP (4")
- T13 YELLOW DOUBLE CENTER (4")
- T20 WHITE EDGELINE (6")
- T21 WHITE SOLID LANE LINE (6")
- T22 10FT. WHITE SKIP (6")
- T23 3FT.-9FT./SP WHITE MINISKIP (6")
- T24 2FT.-6FT./SP WHITE MINISKIP (6")
- T30 YELLOW EDGELINE (6")
- T31 YELLOW SINGLE CENTER (6")
- T32 10 FT. YELLOW SKIP (6")
- T33 YELLOW DOUBLE CENTER (6")
- T42 YELLOW DIAGONAL (8")
- T46 WHITE CROSSWALK LINE (8")
- T50 WHITE GORELINE (12")
- T52 YELLOW DIAGONAL (12")
- T53 WHITE SOLID LANE LINE (12")
- T54 3FT.-9FT./SP WHITE MINISKIP (12")
- T61 WHITE STOPBAR (24")

COLD APPLIED (TYPE III) LINES

- C20 WHITE EDGELINE (6")
- C22 10 FT. WHITE SKIP (6")
- C23 3FT.- 9FT./ SP WHITE MINISKIP (6")
- C30 YELLOW EDGELINE (6")

THERMOPLASTIC SYMBOLS (90 MILS)

- T70 LEFT TURN ARROW
- T71 RIGHT TURN ARROW
- T72 STRAIGHT ARROW
- T73 COMBO. LEFT/STRAIGHT ARROW
- T74 COMBO. RIGHT /STRAIGHT ARROW
- T79 MERGE ARROW
- T80 WRONG-WAY RAMP ARROW
- T100 ALPHANUMERIC CHAR.
- T103 24" YIELD LINE TRIANGLE

PAVEMENT MARKERS

- MB PERMANENT RAISED (CRYSTAL & RED)
- ME SNOWPLOWABLE (YELLOW & YELLOW)
- MF SNOWPLOWABLE (CRYSTAL & RED)

NAD 83/2011

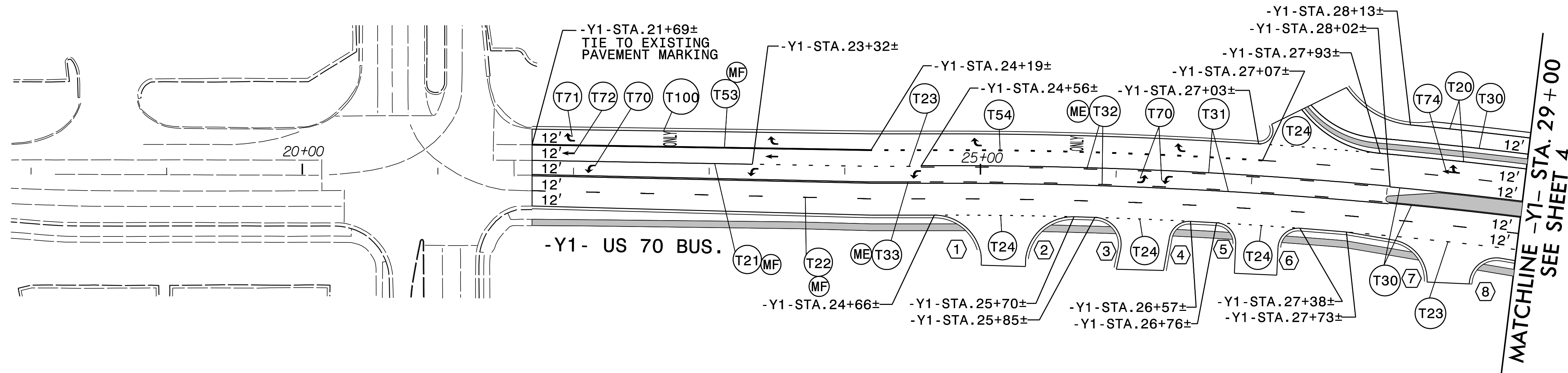

NOTES:

- 1) (#) SEE PMP-2B AND ROADWAY PLAN FOR CURB RAMP INFORMATION.
- 2) ALL LANE WIDTHS ARE 12' UNLESS OTHERWISE SHOWN.

9/19/2023 10:41:00 AM psh06.dgn

**RKK**  
 P: (919) 578-9500  
 8601 Six Forks Road Forum 1 Suite 700 | Raleigh, North Carolina 27615  
 NC License No. F-0112  
 Responsive People | Creative Solutions



# PAVEMENT MARKING SCHEDULE

## THERMOPLASTIC LINES (90 MILS)

- T1 WHITE EDGE LINE (4")
- T2 WHITE SOLID LANE LINE (4")
- T4 3FT.-9FT./SP WHITE MINISKIP (4")
- T5 2FT.-6FT./SP WHITE MINISKIP (4")
- T11 YELLOW SINGLE CENTER (4")
- T12 10FT. YELLOW SKIP (4")
- T13 YELLOW DOUBLE CENTER (4")
- T20 WHITE EDGELINE (6")
- T21 WHITE SOLID LANE LINE (6")
- T22 10FT. WHITE SKIP (6")
- T23 3FT.-9FT./SP WHITE MINISKIP (6")
- T24 2FT.-6FT./SP WHITE MINISKIP (6")
- T30 YELLOW EDGELINE (6")
- T31 YELLOW SINGLE CENTER (6")
- T32 10 FT. YELLOW SKIP (6")
- T33 YELLOW DOUBLE CENTER (6")
- T42 YELLOW DIAGONAL (8")
- T46 WHITE CROSSWALK LINE (8")
- T50 WHITE GORELINE (12")
- T52 YELLOW DIAGONAL (12")
- T53 WHITE SOLID LANE LINE (12")
- T54 3FT.-9FT./SP WHITE MINISKIP (12")
- T61 WHITE STOPBAR (24")

## COLD APPLIED (TYPE III) LINES

- C20 WHITE EDGELINE (6")
- C22 10 FT. WHITE SKIP (6")
- C23 3FT.-9FT./SP WHITE MINISKIP (6")
- C30 YELLOW EDGELINE (6")

## THERMOPLASTIC SYMBOLS (90 MILS)

- T70 LEFT TURN ARROW
- T71 RIGHT TURN ARROW
- T72 STRAIGHT ARROW
- T73 COMBO. LEFT/STRAIGHT ARROW
- T74 COMBO. RIGHT /STRAIGHT ARROW
- T79 MERGE ARROW
- T80 WRONG-WAY RAMP ARROW
- T100 ALPHANUMERIC CHAR.
- T103 24" YIELD LINE TRIANGLE

## PAVEMENT MARKERS

- MB PERMANENT RAISED (CRYSTAL & RED)
- ME SNOWFLOWABLE (YELLOW & YELLOW)
- MF SNOWFLOWABLE (CRYSTAL & RED)

MATCHLINE -Y1- STA. 47+00 SEE SHEET 4

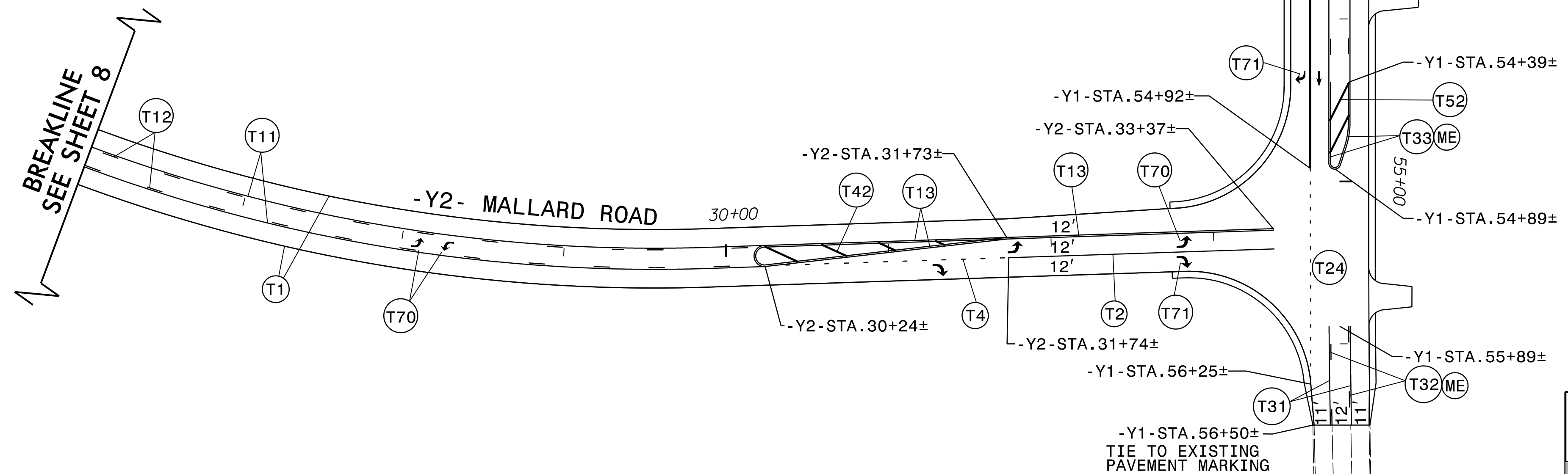

PROJECT I-5972	SHEET NO. PMP-7
APPROVED: <i>Kevin Bishy</i> 9/19/2023	
DATE: 9/19/2023	
SEAL 	
DOCUMENT NOT CONSIDERED FINAL UNLESS ALL SIGNATURES COMPLETED	

NOTE:  
ALL LANE WIDTHS ARE 12'  
UNLESS OTHERWISE SHOWN.

**RKK**  
P: (919) 578-9500  
8601 Six Forks Road Forum 1 Suite 700 | Raleigh, North Carolina 27615  
NC License No. F-0112  
Responsive People | Creative Solutions

PAVEMENT MARKING DETAIL

9/19/2023 10:47:23 AM psh07.dgn

NAD 83/2011

**MATCHLINE**  
-Y3- STA. 20+50  
SEE SHEET 4

**PAVEMENT MARKING SCHEDULE**

<p><b>THERMOPLASTIC LINES (90 MILS)</b></p> <p>T1 WHITE EDGE LINE (4")</p> <p>T2 WHITE SOLID LANE LINE (4")</p> <p>T4 3FT.-9FT./SP WHITE MINISKIP (4")</p> <p>T5 2FT.-6FT./SP WHITE MINISKIP (4")</p> <p>T11 YELLOW SINGLE CENTER (4")</p> <p>T12 10FT. YELLOW SKIP (4")</p> <p>T13 YELLOW DOUBLE CENTER (4")</p> <p>T20 WHITE EDGELINE (6")</p> <p>T21 WHITE SOLID LANE LINE (6")</p> <p>T22 10FT. WHITE SKIP (6")</p> <p>T23 3FT.-9FT. /SP WHITE MINISKIP (6")</p> <p>T24 2FT.-6FT./SP WHITE MINISKIP (6")</p> <p>T30 YELLOW EDGELINE (6")</p> <p>T31 YELLOW SINGLE CENTER (6")</p> <p>T32 10 FT. YELLOW SKIP (6")</p> <p>T33 YELLOW DOUBLE CENTER (6")</p> <p>T42 YELLOW DIAGONAL (8")</p> <p>T46 WHITE CROSSWALK LINE (8")</p> <p>T50 WHITE GORELINE (12")</p> <p>T52 YELLOW DIAGONAL (12")</p> <p>T53 WHITE SOLID LANE LINE (12")</p> <p>T54 3FT.-9FT./SP WHITE MINISKIP (12")</p> <p>T61 WHITE STOPBAR (24")</p>	<p><b>COLD APPLIED (TYPE III) LINES</b></p> <p>C20 WHITE EDGELINE (6")</p> <p>C22 10 FT. WHITE SKIP (6")</p> <p>C23 3FT.- 9FT./ SP WHITE MINISKIP (6")</p> <p>C30 YELLOW EDGELINE (6")</p>
<p><b>THERMOPLASTIC SYMBOLS (90 MILS)</b></p> <p>T70 LEFT TURN ARROW</p> <p>T71 RIGHT TURN ARROW</p> <p>T72 STRAIGHT ARROW</p> <p>T73 COMBO. LEFT/STRAIGHT ARROW</p> <p>T74 COMBO. RIGHT /STRAIGHT ARROW</p> <p>T79 MERGE ARROW</p> <p>T80 WRONG-WAY RAMP ARROW</p> <p>T100 ALPHANUMERIC CHAR.</p> <p>T103 24" YIELD LINE TRIANGLE</p>	<p><b>PAVEMENT MARKERS</b></p> <p>MB PERMANENT RAISED (CRYSTAL &amp; RED)</p> <p>ME SNOWPLOWABLE (YELLOW &amp; YELLOW)</p> <p>MF SNOWPLOWABLE (CRYSTAL &amp; RED)</p>

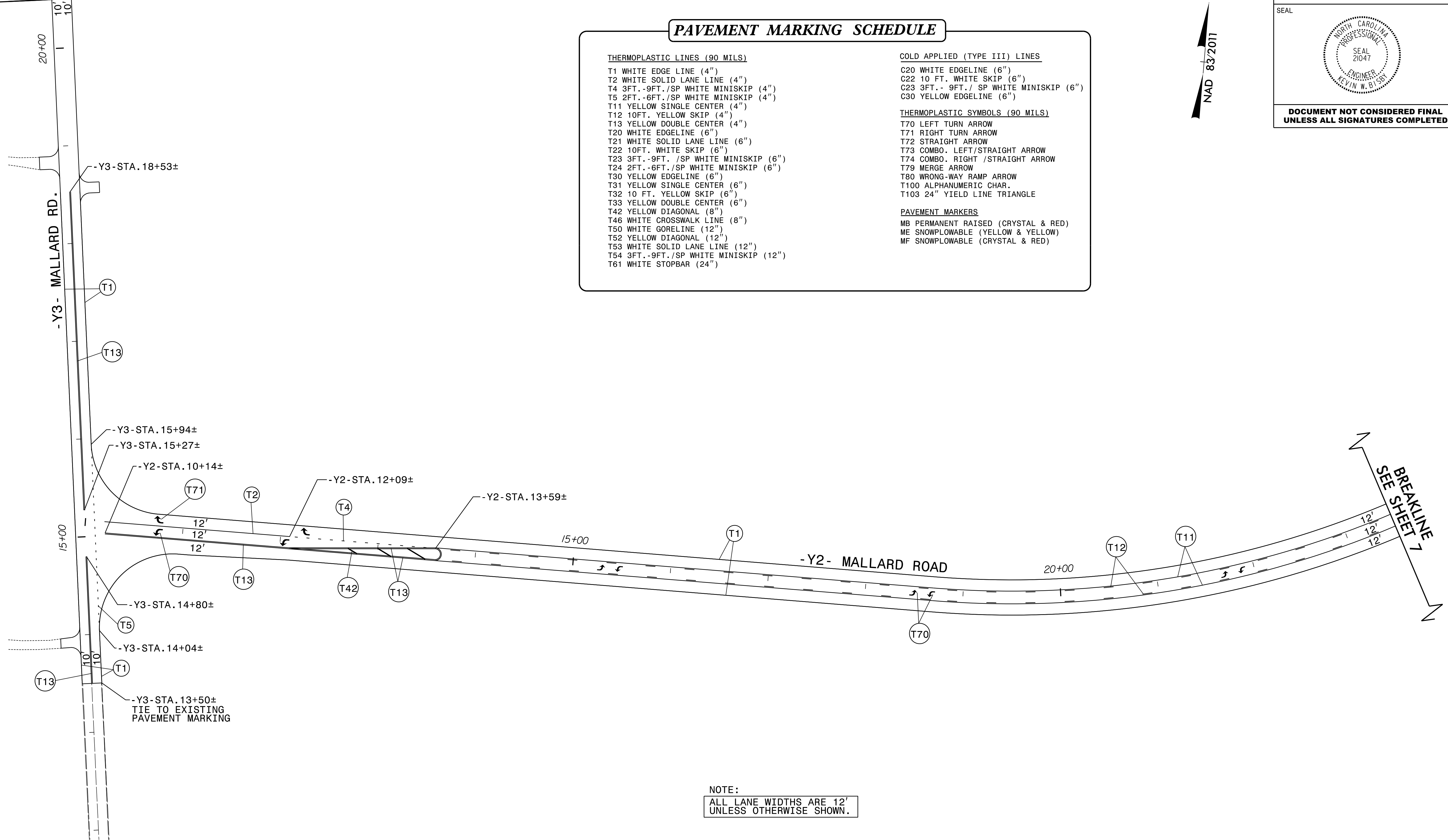

**NOTE:**  
ALL LANE WIDTHS ARE 12'  
UNLESS OTHERWISE SHOWN.

9/19/2023 10:41:00 AM psh08.dgn