





9/19/2023
 15912-TMP-FSH37.dgn
 R015by

| | | |
|--|--|---|
| APPROVED:  DATE: 9/19/2023 SEAL |   | PHASE III - STEP 3 <p style="text-align: center;">DOCUMENT NOT CONSIDERED FINAL UNLESS ALL SIGNATURES COMPLETED</p> |
|--|--|---|

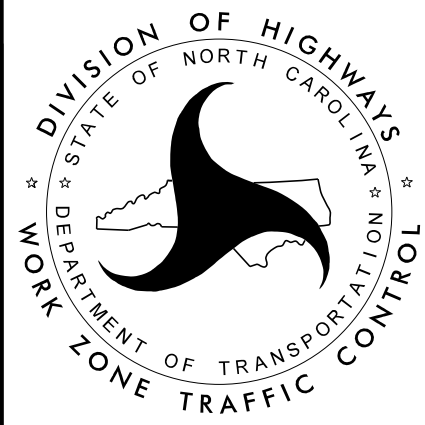
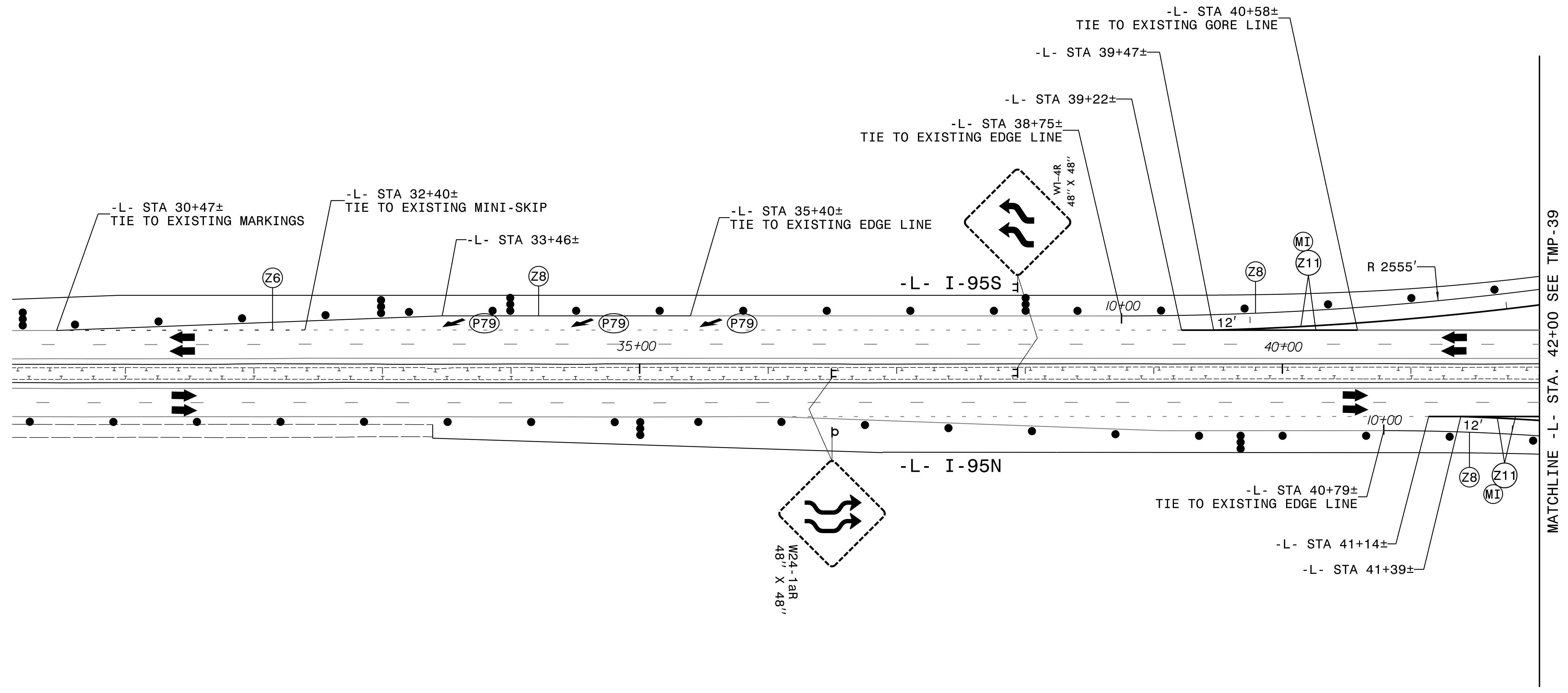

MATCHLINE -L- STA. 42+00 SEE TMP-39

9/19/2023
 15972-TMP-FSH38.dgn
 R015by

APPROVED: 
DocuSigned by: Kevin Bishop
 B00802628912474

DATE: 9/19/2023

SEAL

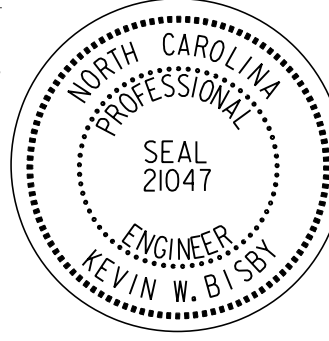

**DOCUMENT NOT CONSIDERED FINAL
 UNLESS ALL SIGNATURES COMPLETED**

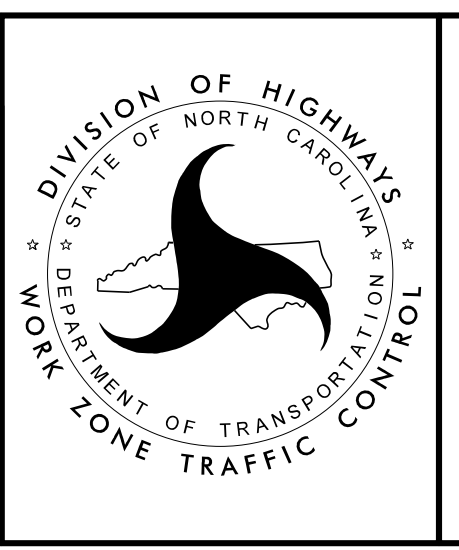

PHASE III - STEP 4

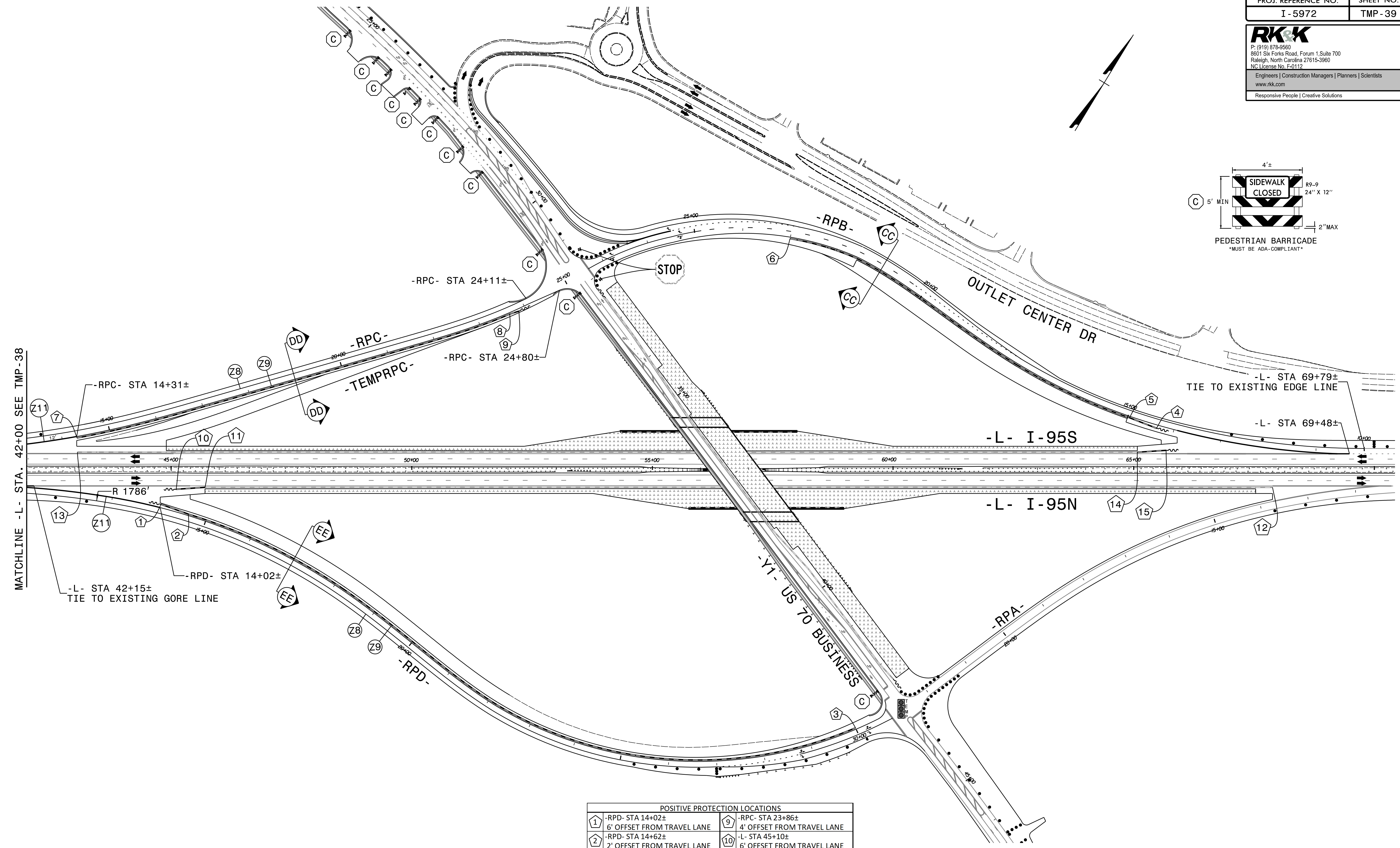
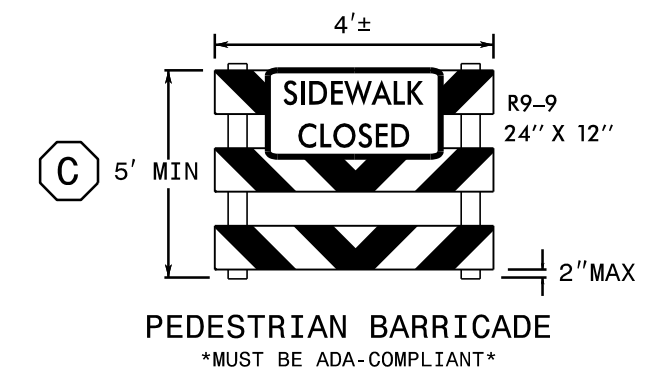

| POSITIVE PROTECTION LOCATIONS | | | |
|-------------------------------|--|----|--|
| 1 | -RPD- STA 14+02± 6' OFFSET FROM TRAVEL LANE | 9 | -RPC- STA 23+86± 4' OFFSET FROM TRAVEL LANE |
| 2 | -RPD- STA 14+62± 2' OFFSET FROM TRAVEL LANE | 10 | -L- STA 45+10± 6' OFFSET FROM TRAVEL LANE |
| 3 | -RPD- STA 30+00± 2' OFFSET FROM TRAVEL LANE | 11 | -L- STA 45+70± 2' OFFSET FROM TRAVEL LANE |
| 4 | -RPB- STA 14+36± 6' OFFSET FROM TRAVEL LANE | 12 | -L- STA 67+88± 2' OFFSET FROM TRAVEL LANE |
| 5 | -RPB- STA 14+96± 2' OFFSET FROM TRAVEL LANE | 13 | -L- STA 43+05± 2' OFFSET FROM TRAVEL LANE |
| 6 | -RPB- STA 23+00± 2' OFFSET FROM TRAVEL LANE | 14 | -L- STA 65+07± 2' OFFSET FROM TRAVEL LANE |
| 7 | -RPC- STA 14+31± 2' OFFSET FROM TRAVEL LANE | 15 | -L- STA 65+67± 6' OFFSET FROM TRAVEL LANE |
| 8 | -RPC- STA 23+66± 2' OFFSET FROM TRAVEL LANE | | |

SEE TMP-39A FOR SECTION VIEWS.
 SEE TMP-39B AND 39C FOR ADDITIONAL PAVEMENT MARKINGS.

APPROVED: 
 DATE: 9/19/2023

SEAL

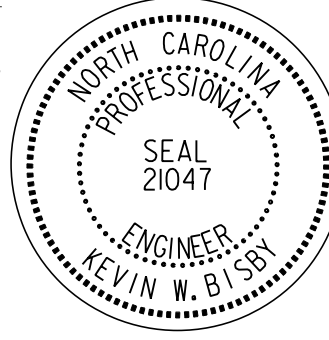

**DOCUMENT NOT CONSIDERED FINAL
 UNLESS ALL SIGNATURES COMPLETED**

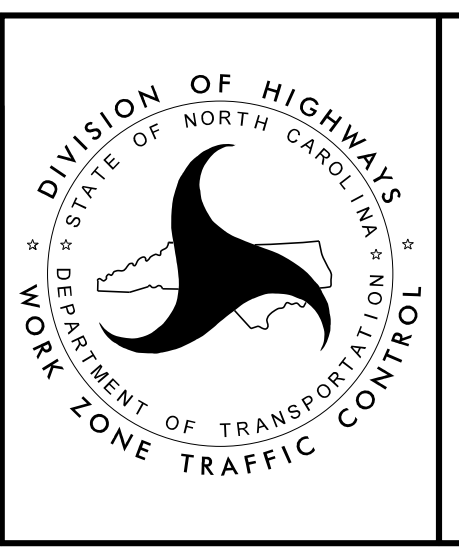

PHASE III - STEP 4

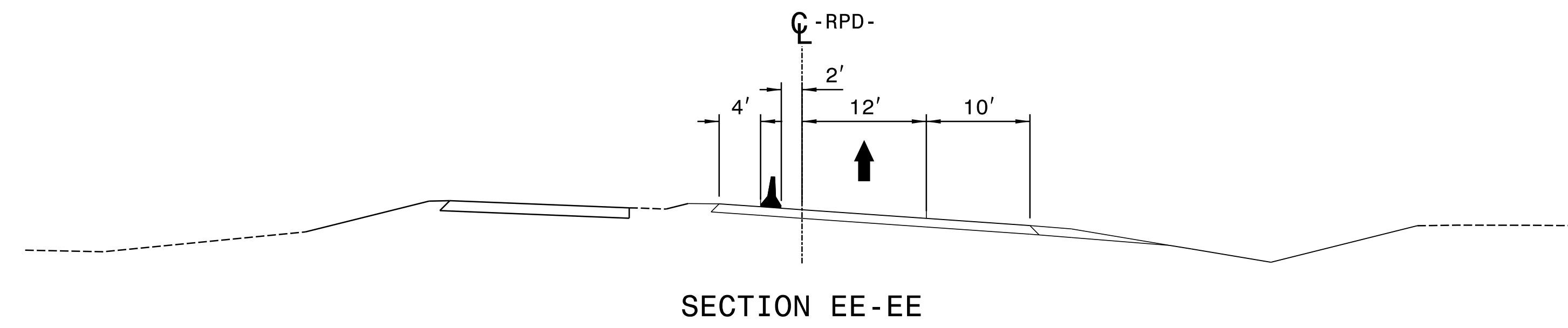
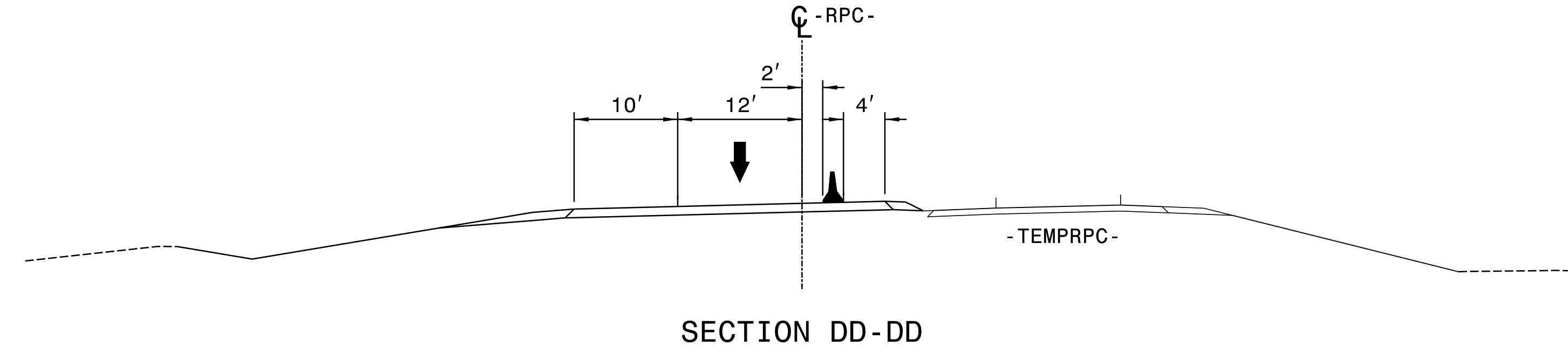
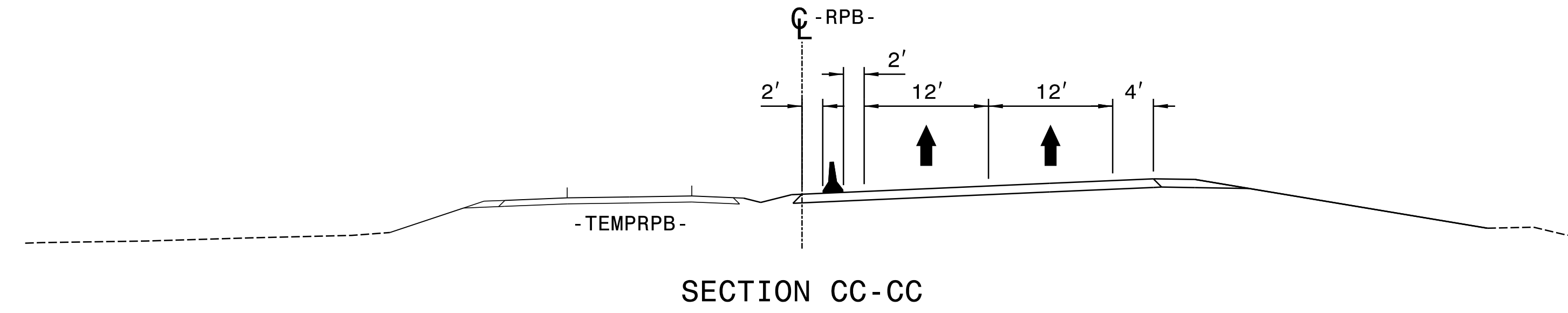

9/19/2023
 15912_TMP_FSH39A.dgn
 R015by

APPROVED: 
DocuSigned by: Kevin Bishop
800802028912472

DATE: 9/19/2023

SEAL

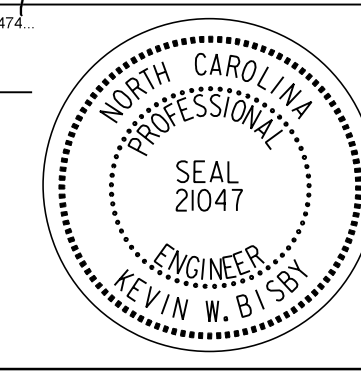

**DOCUMENT NOT CONSIDERED FINAL
UNLESS ALL SIGNATURES COMPLETED**

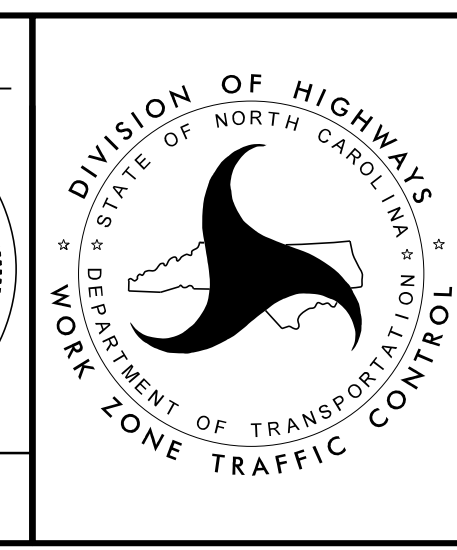

PHASE III - STEP 4

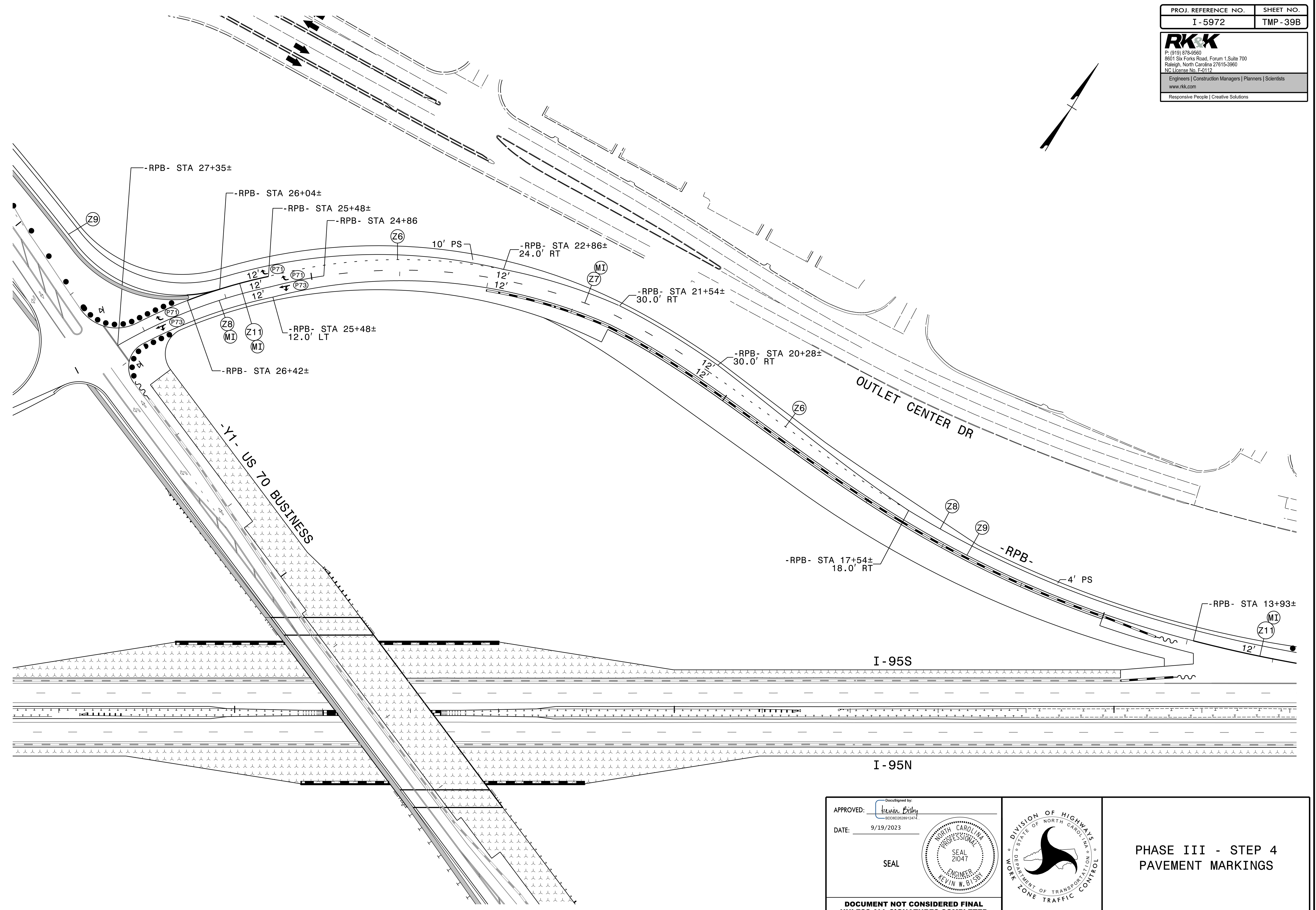

9/19/2023
 15972-TMP-FSH39B.dgn
 R015dy

APPROVED: *Kevin Bishop*
DocuSigned by: Kevin Bishop
800802028912472

DATE: 9/19/2023

SEAL

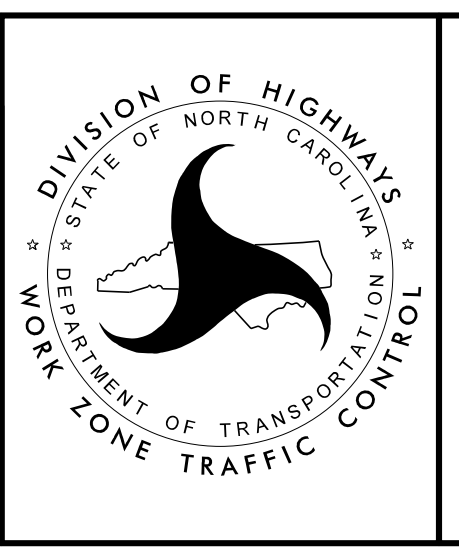

**PHASE III - STEP 4
 PAVEMENT MARKINGS**

**DOCUMENT NOT CONSIDERED FINAL
 UNLESS ALL SIGNATURES COMPLETED**

| | |
|---------------------|-----------|
| PROJ. REFERENCE NO. | SHEET NO. |
| I - 5972 | TMP-39C |

RKK
 P: (919) 878-8560
 8601 Six Forks Road, Forum 1, Suite 700
 Raleigh, North Carolina 27615-3960
 NC License No. F-0112
 Engineers | Construction Managers | Planners | Scientists
 www.rkk.com
 Responsive People | Creative Solutions

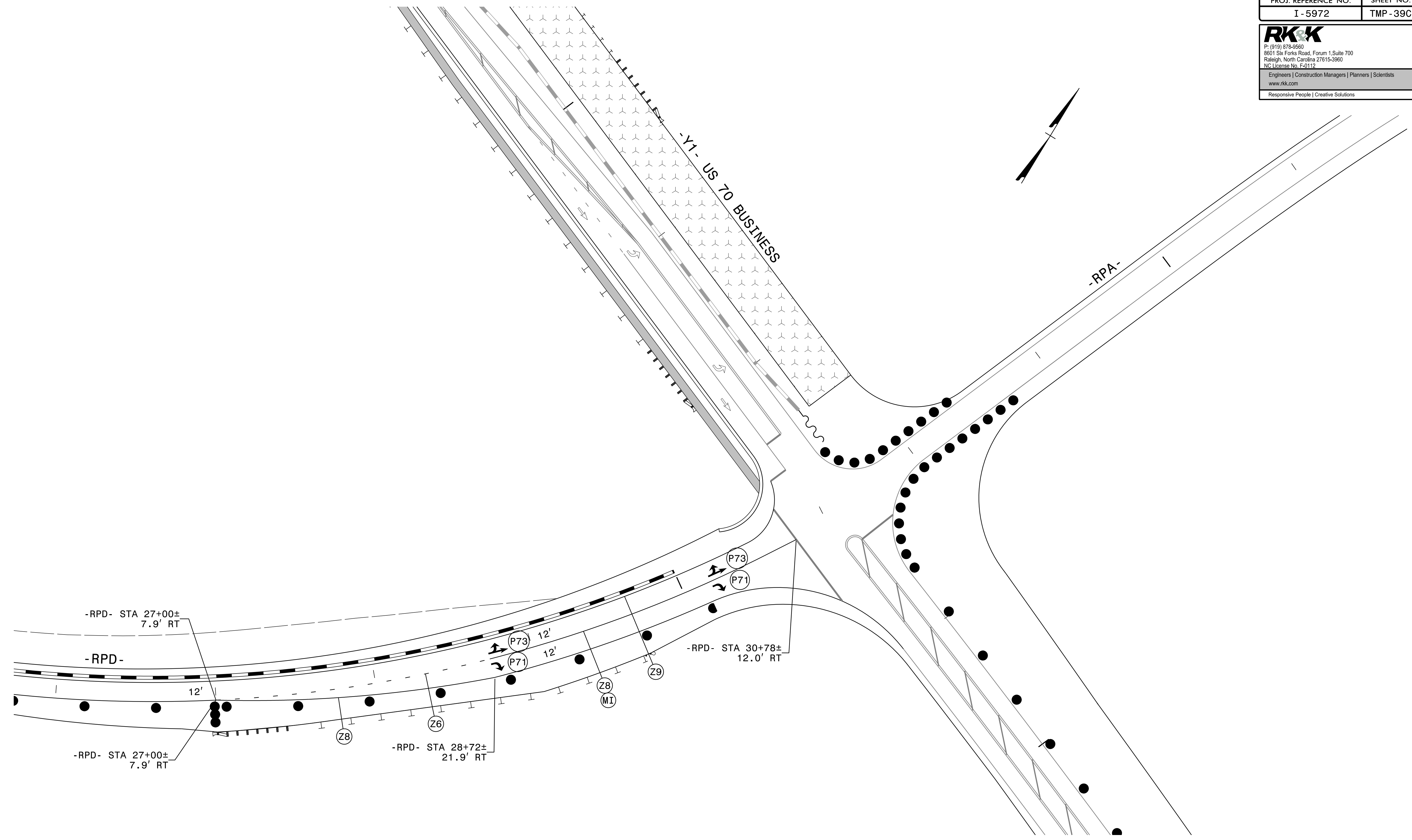

9/19/2023
 15912-TMP-FSH39C.dgn
 R015dy

APPROVED: 
DocuSigned by: Kevin Bishop
800802028912472

DATE: 9/19/2023

SEAL

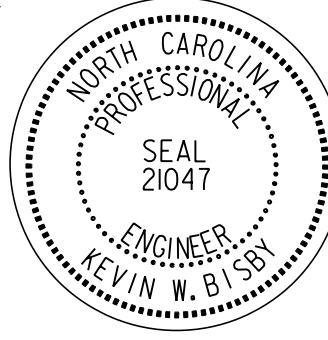

**DOCUMENT NOT CONSIDERED FINAL
UNLESS ALL SIGNATURES COMPLETED**

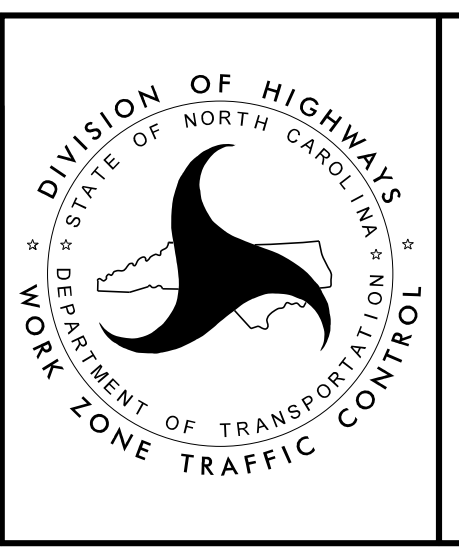

**PHASE III - STEP 4
PAVEMENT MARKINGS**

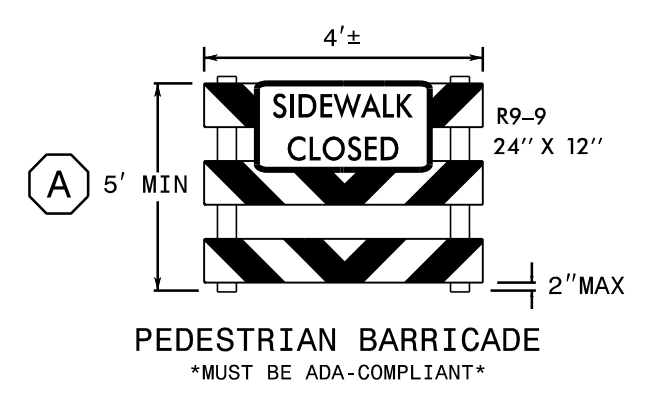
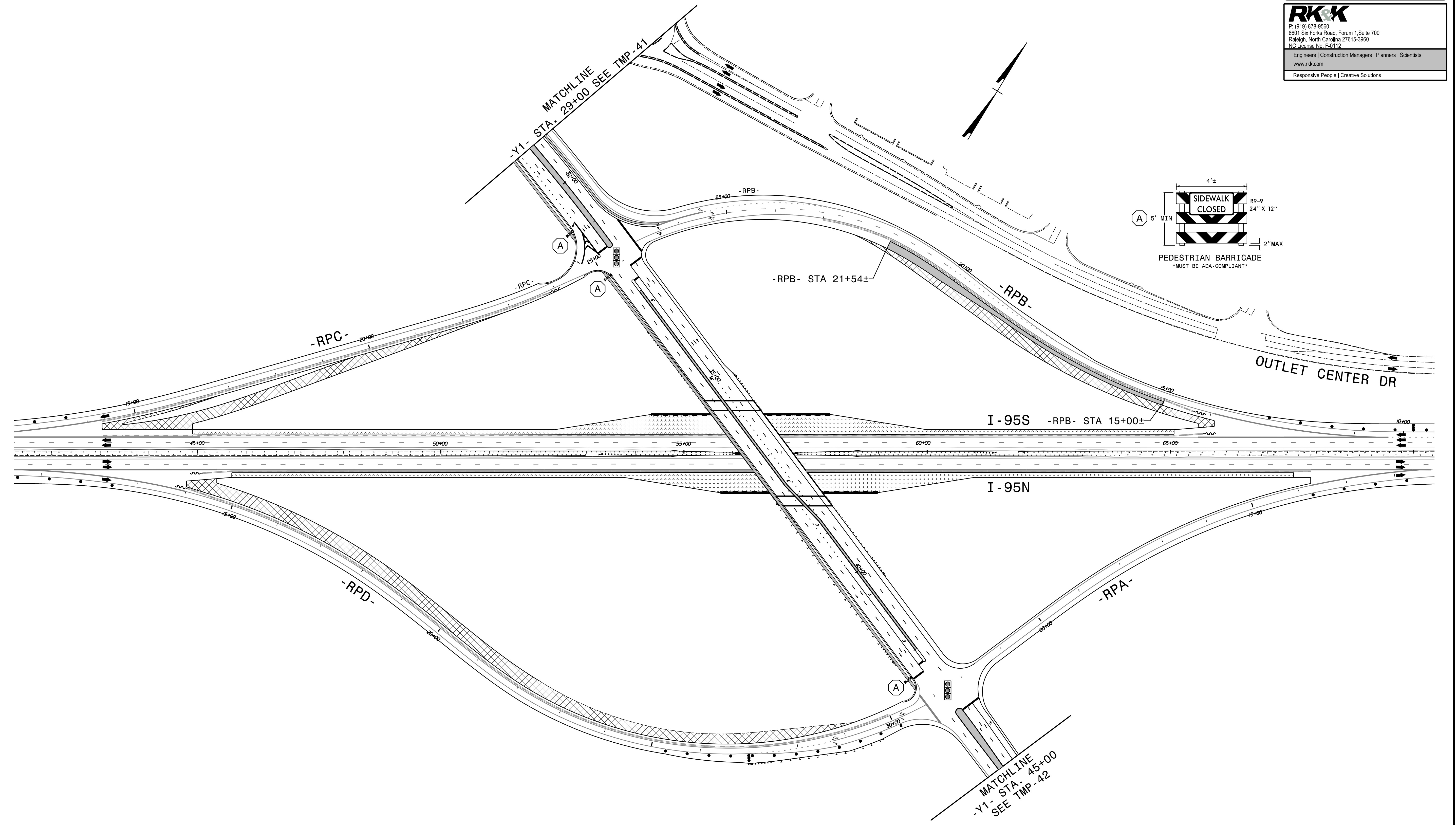

SEE TMP-40A AND 40B FOR PAVEMENT MARKINGS
 ERECT PROPOSED SIGNS AS APPLICABLE.

APPROVED: *Kevin Bisby*
DocuSigned by: Kevin Bisby 800802028912474
 DATE: 9/19/2023

SEAL

**DOCUMENT NOT CONSIDERED FINAL
 UNLESS ALL SIGNATURES COMPLETED**

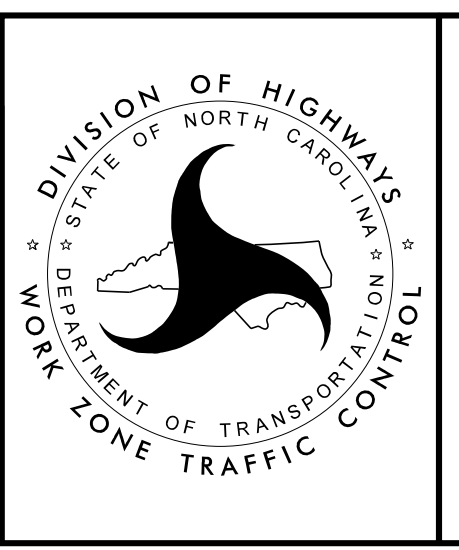

PHASE IV - STEP 1 AND 2

9/19/2023
 15972_TMP_FSH40.dgn
 K015by

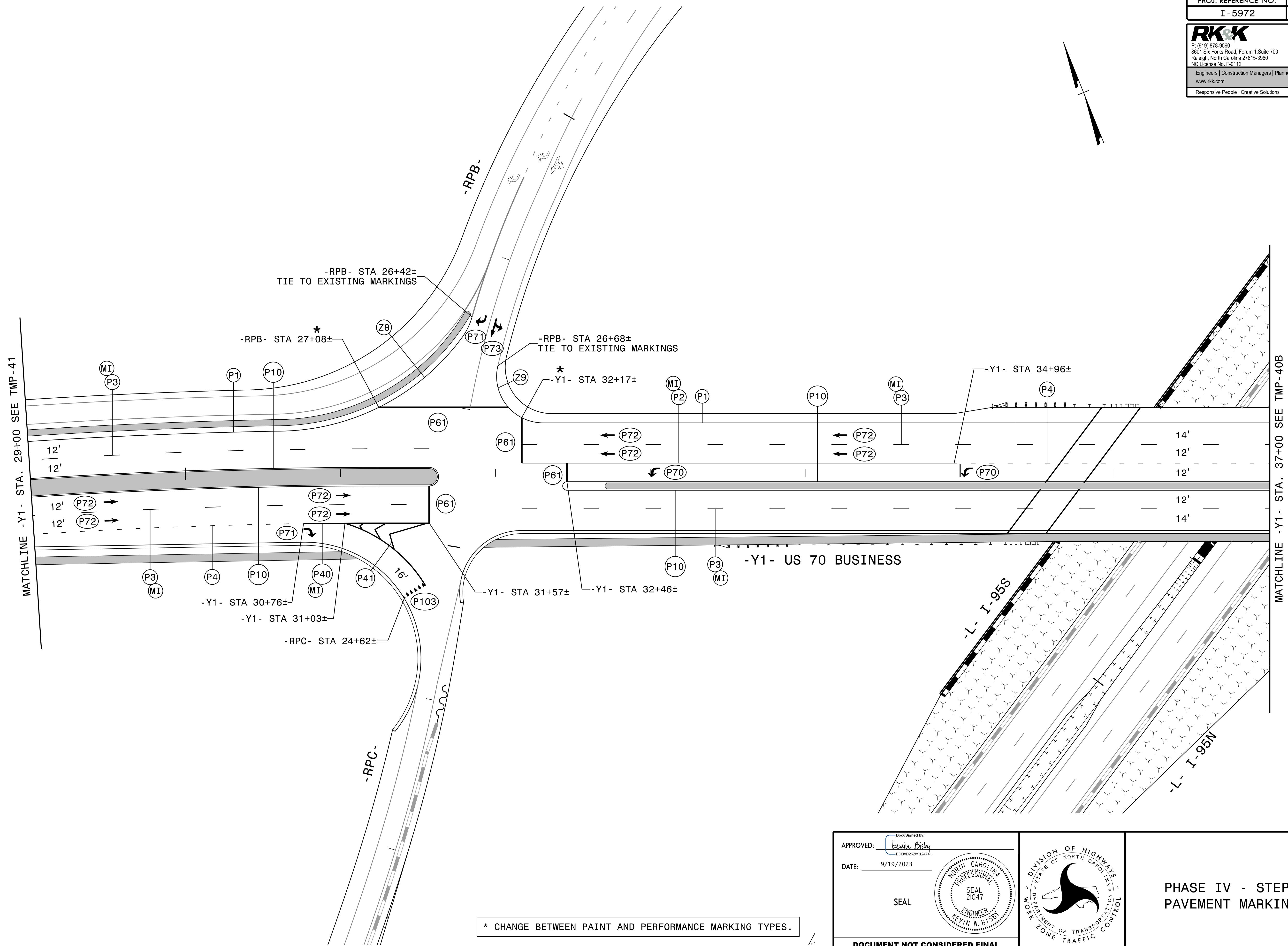
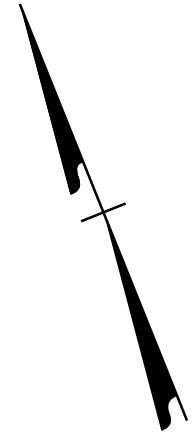

MATCHLINE -Y1- STA. 29+00 SEE TMP-41

MATCHLINE -Y1- STA. 37+00 SEE TMP-40B

* CHANGE BETWEEN PAINT AND PERFORMANCE MARKING TYPES.

9/19/2023
 15972-TMP-FSH40A.dgn
 K015by

APPROVED: 
 DATE: 9/19/2023

SEAL



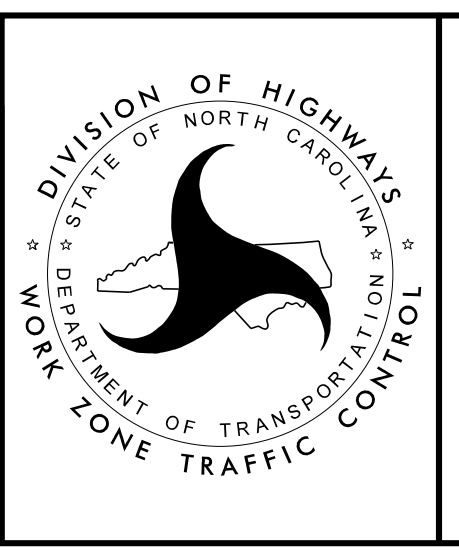

**DOCUMENT NOT CONSIDERED FINAL
 UNLESS ALL SIGNATURES COMPLETED**

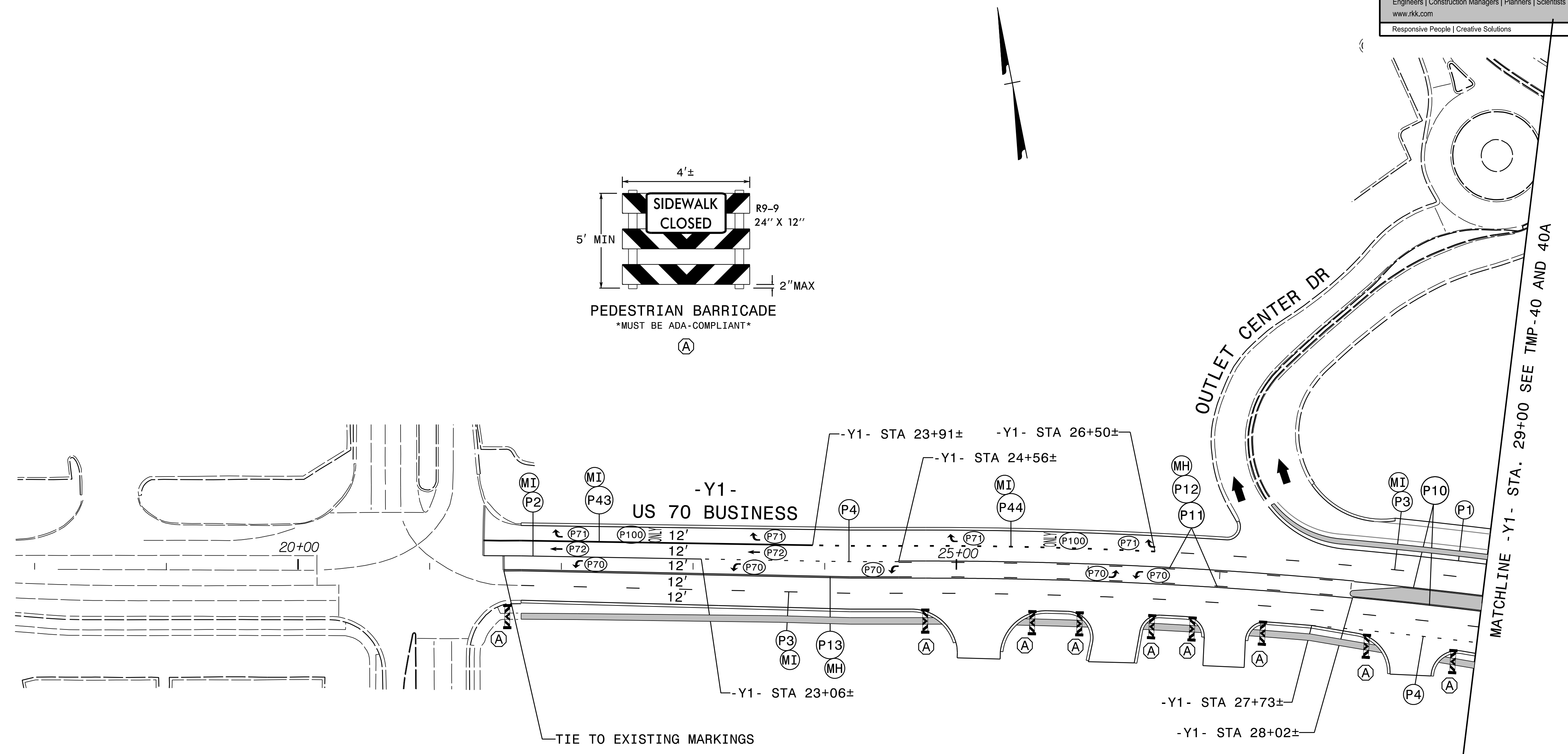
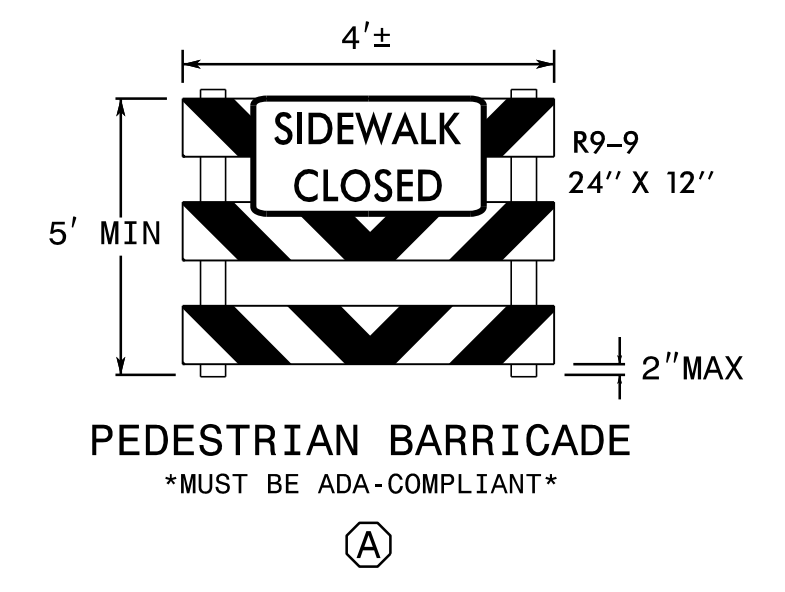

**PHASE IV - STEP 2
 PAVEMENT MARKINGS**



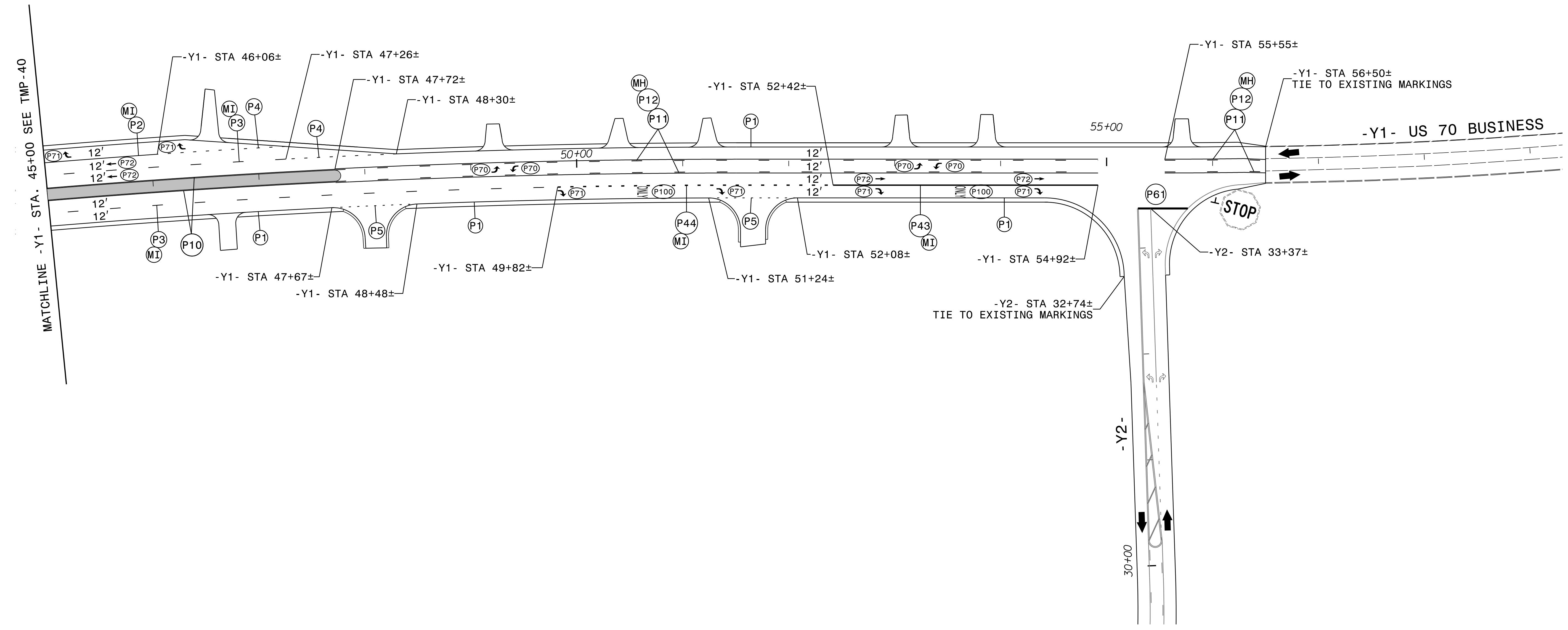
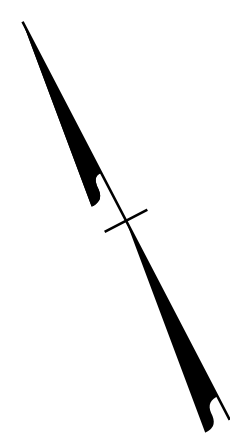

9/19/2023
 15972-TMP-FSH41.dgn
 R015by

| | | | |
|--|---|---|--|
| APPROVED:  DATE: 9/19/2023 SEAL |  |  | <p align="center">PHASE IV - STEP 2</p> |
| <p align="center">DOCUMENT NOT CONSIDERED FINAL UNLESS ALL SIGNATURES COMPLETED</p> | | | |





9/19/2023
 15912_TMP_PSH42.dgn
 R01sby

| | | |
|--|---|---|
| APPROVED:  DATE: 9/19/2023 SEAL |  |  |
| <p style="text-align: center;">DOCUMENT NOT CONSIDERED FINAL UNLESS ALL SIGNATURES COMPLETED</p> | | |

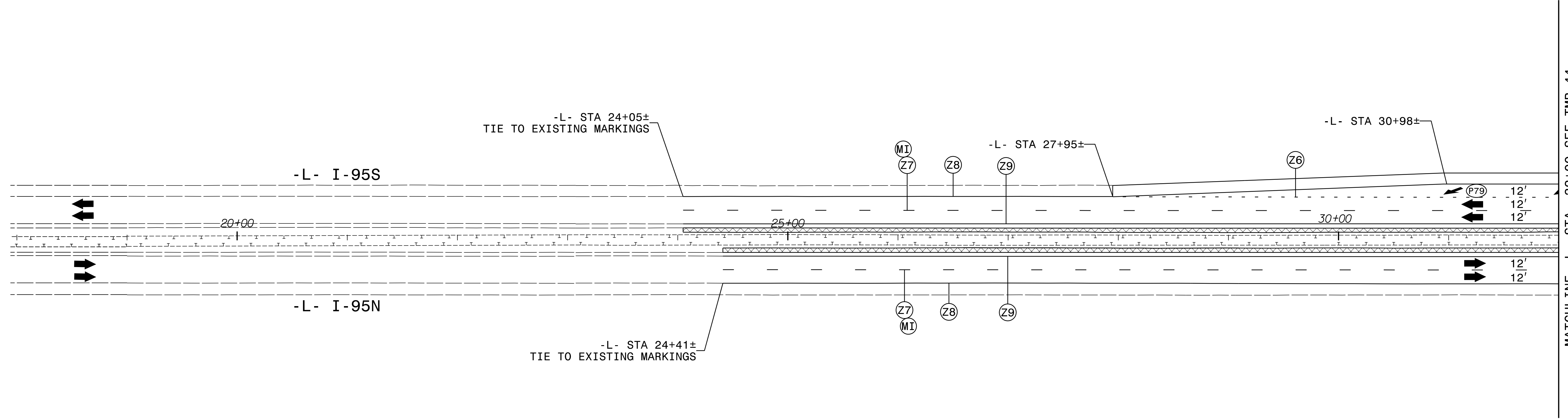
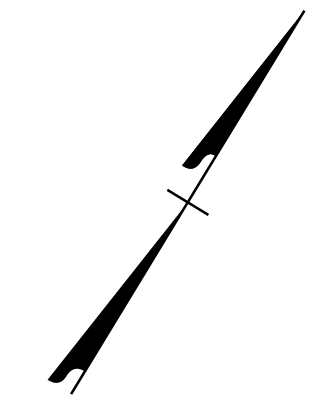
PHASE IV - STEP 2



9/19/2023
15972_TMP_FSH43.dgn
R015by

| | | |
|--|---|---|
| APPROVED:  <small>DocuSigned by: Kevin Bishop 800802028912472</small> DATE: 9/19/2023 SEAL |  |  PHASE IV - STEPS 3 AND 4 |
| <p style="text-align: center;">DOCUMENT NOT CONSIDERED FINAL UNLESS ALL SIGNATURES COMPLETED</p> | | |

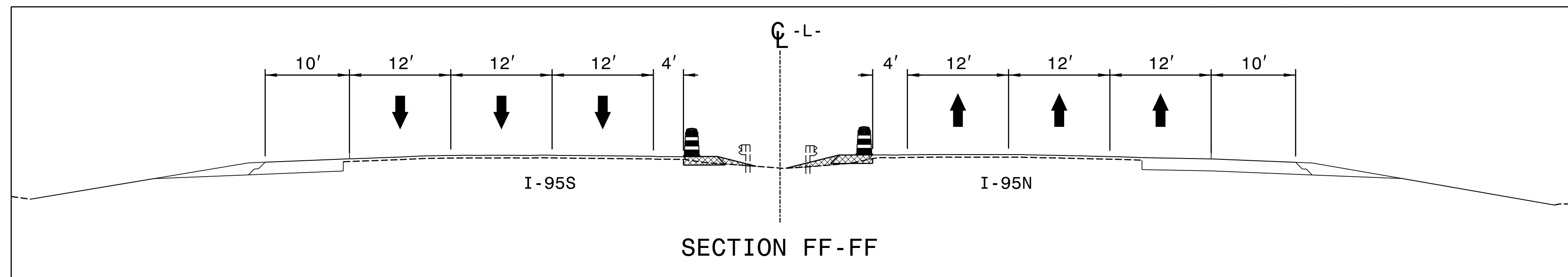
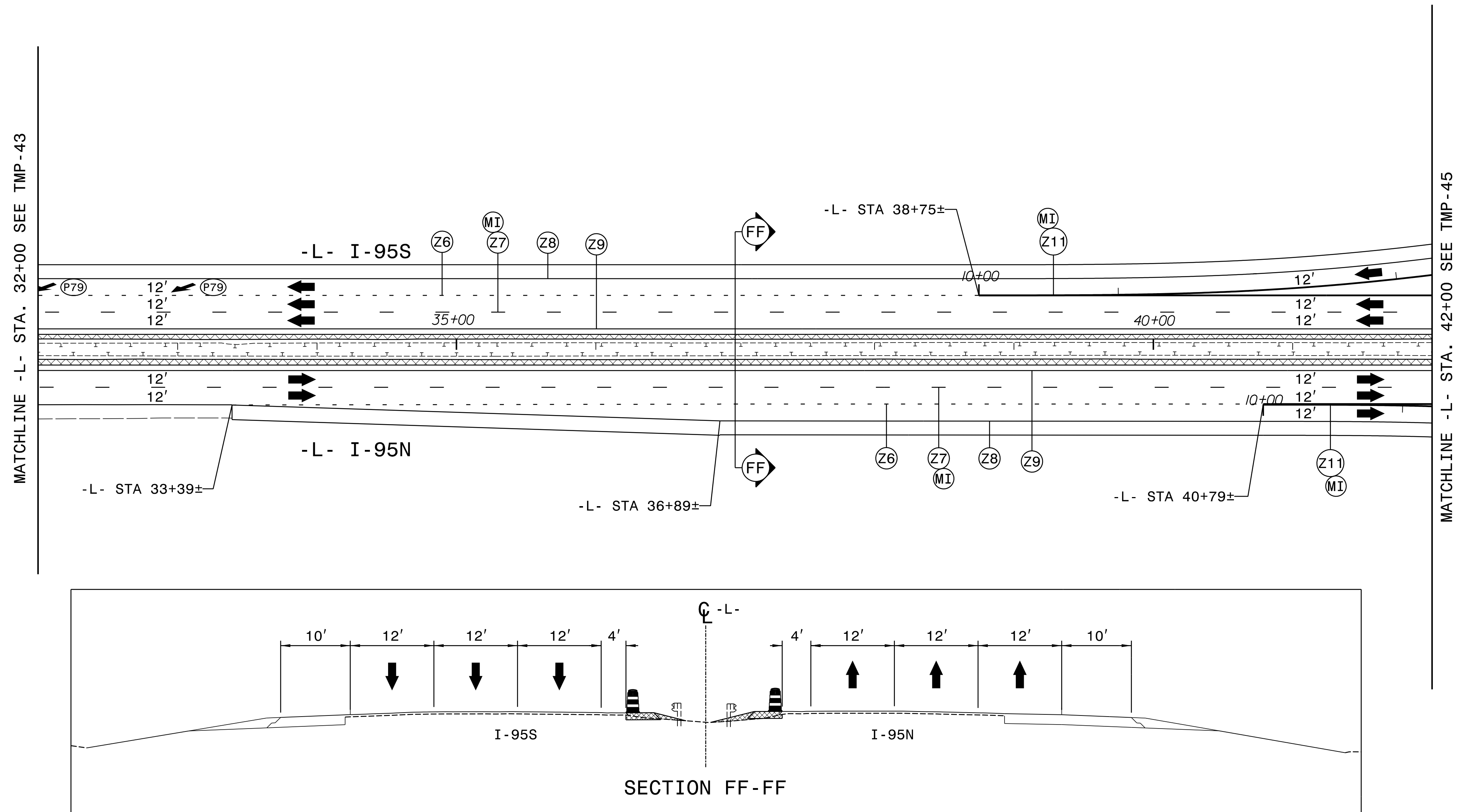
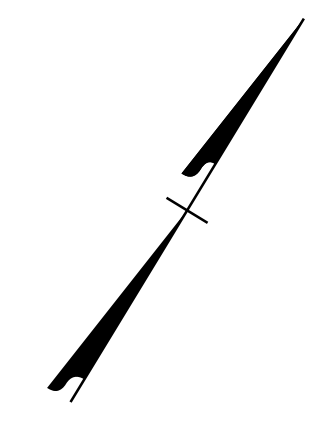

9/19/2023
 15912-TMP-FSH44.dgn
 R015by

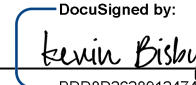
APPROVED: 
 DATE: 9/19/2023

SEAL

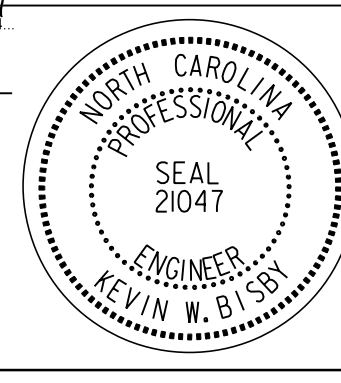
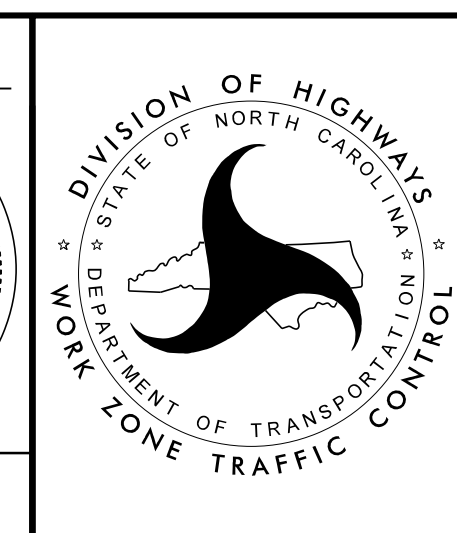

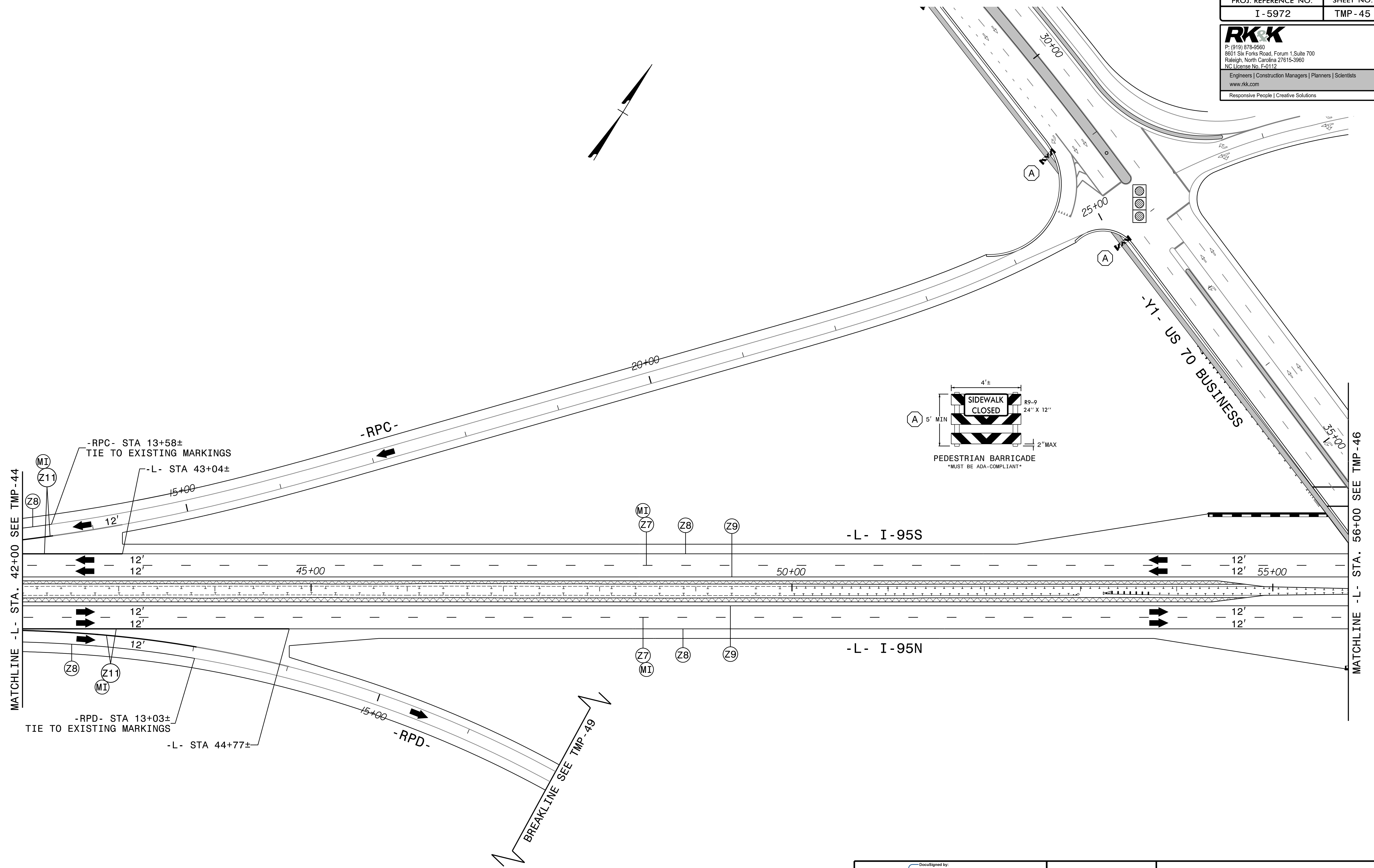

PHASE IV - STEPS 3 AND 4

**DOCUMENT NOT CONSIDERED FINAL
 UNLESS ALL SIGNATURES COMPLETED**

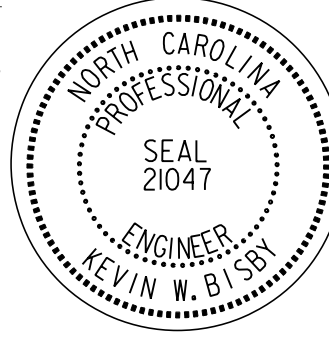
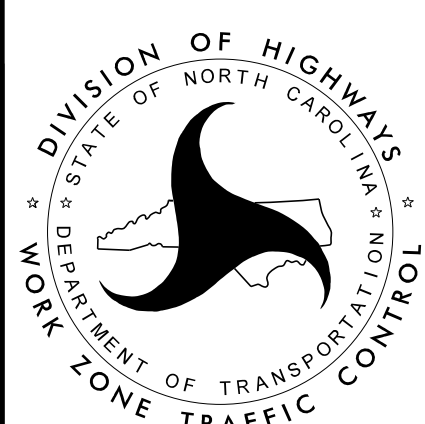

9/19/2023
 15912_TMP_PSH45.dgn
 R015bby

| | | |
|---|---|--------------------------|
| APPROVED:  DATE: 9/19/2023 SEAL:  |  | PHASE IV - STEPS 3 AND 4 |
| DOCUMENT NOT CONSIDERED FINAL UNLESS ALL SIGNATURES COMPLETED | | |

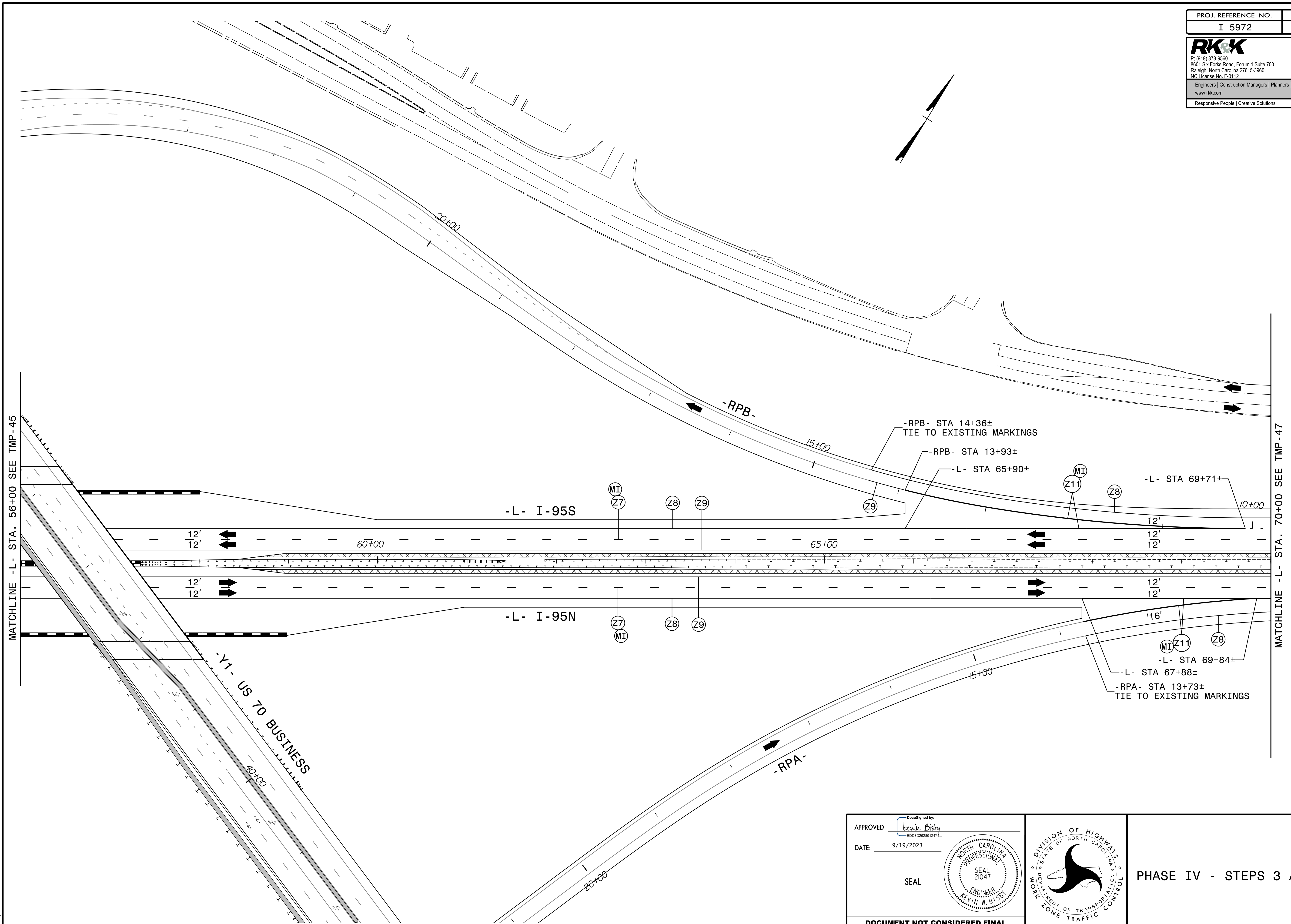

APPROVED: 
 DATE: 9/19/2023
 SEAL

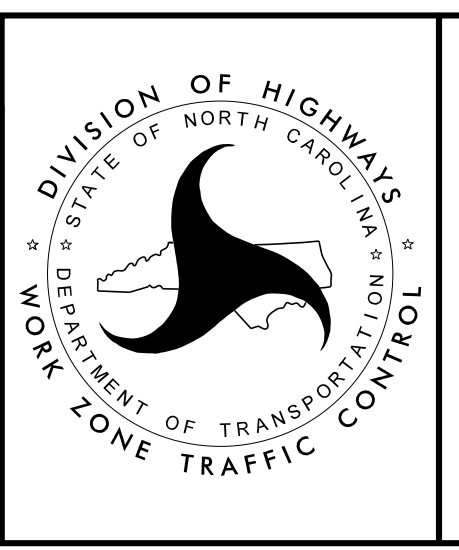

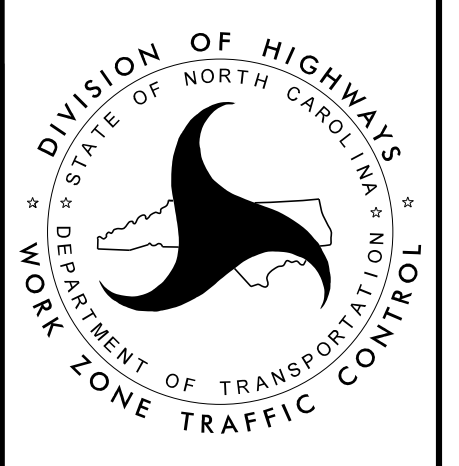

 DIVISION OF HIGHWAYS
 DEPARTMENT OF TRANSPORTATION
 OF NORTH CAROLINA
 OF K ZONE TRAFFIC CONTROL

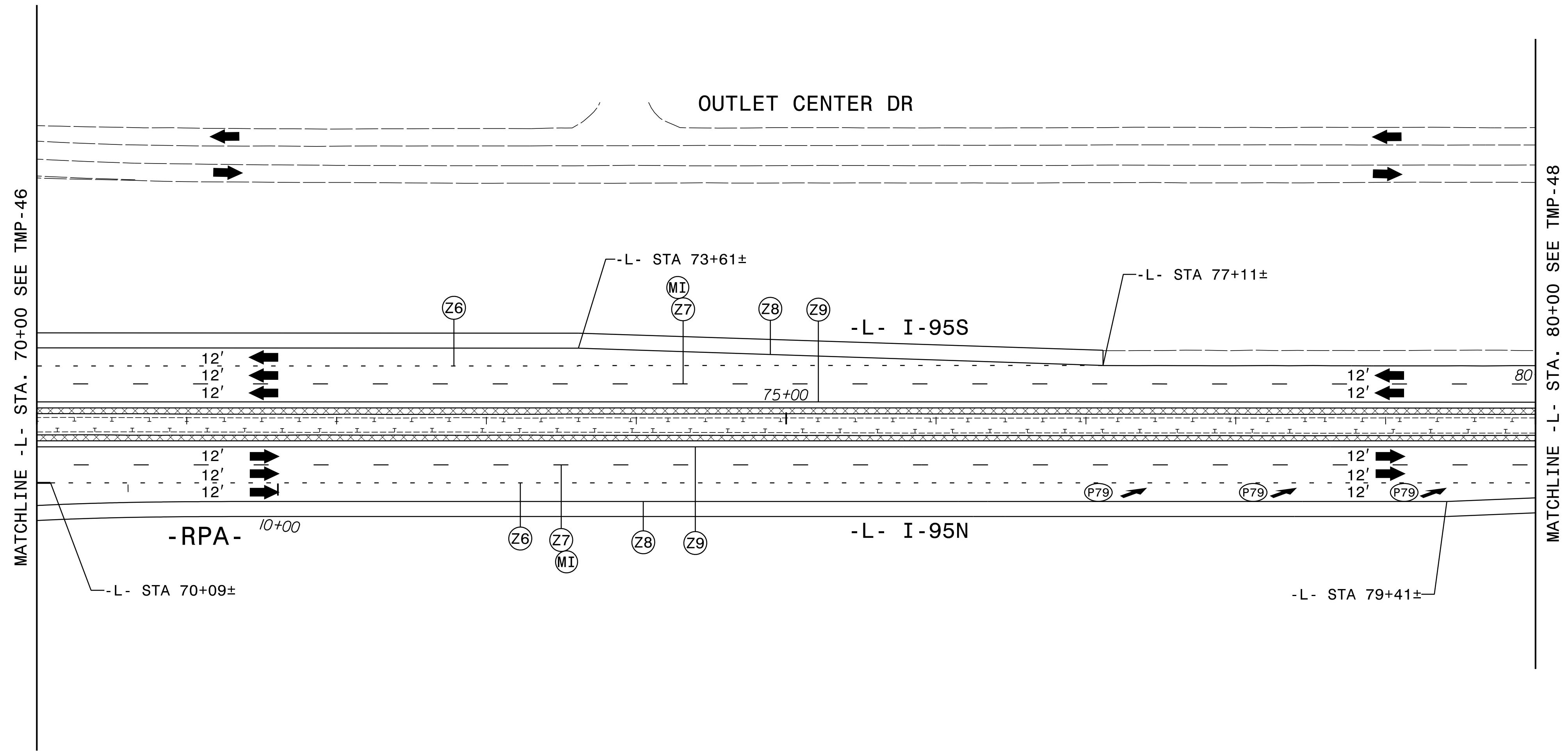
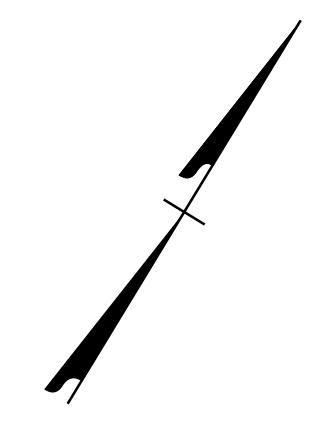
PHASE IV - STEPS 3 AND 4

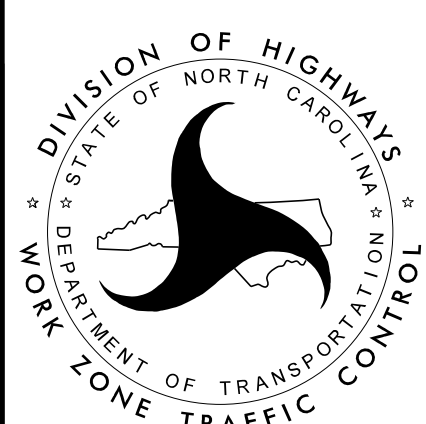

9/19/2023
 15912-TMP-FSH47.dgn
 R015by

| | | | |
|--|---|---|--------------------------|
| APPROVED:  DATE: 9/19/2023 SEAL |  |  | PHASE IV - STEPS 3 AND 4 |
| DOCUMENT NOT CONSIDERED FINAL UNLESS ALL SIGNATURES COMPLETED | | | |

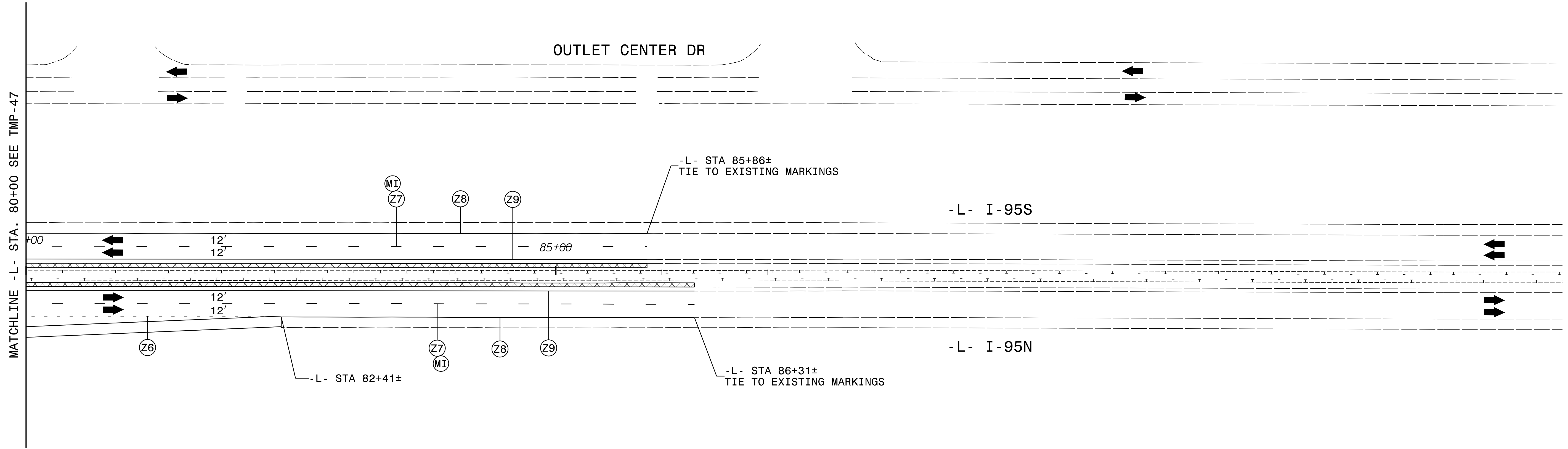
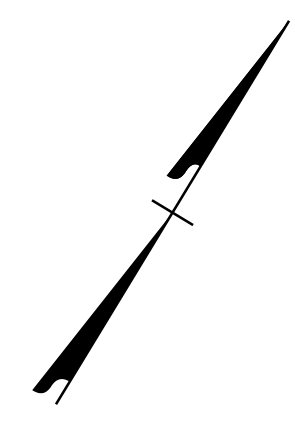

9/19/2023
 15912-TMP-FSH48.dgn
 R015by

APPROVED: 
DocuSigned by: Kevin Bishop
800802028912472

DATE: 9/19/2023

SEAL

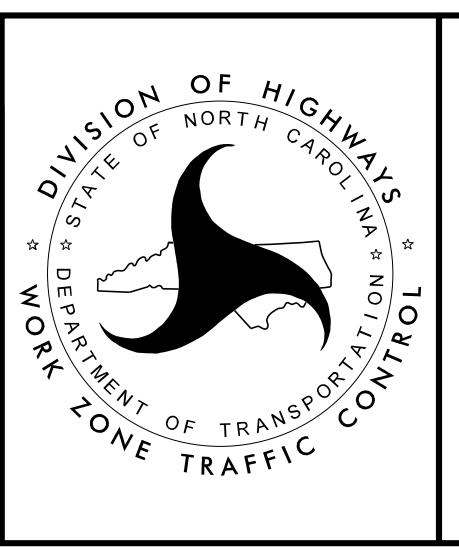



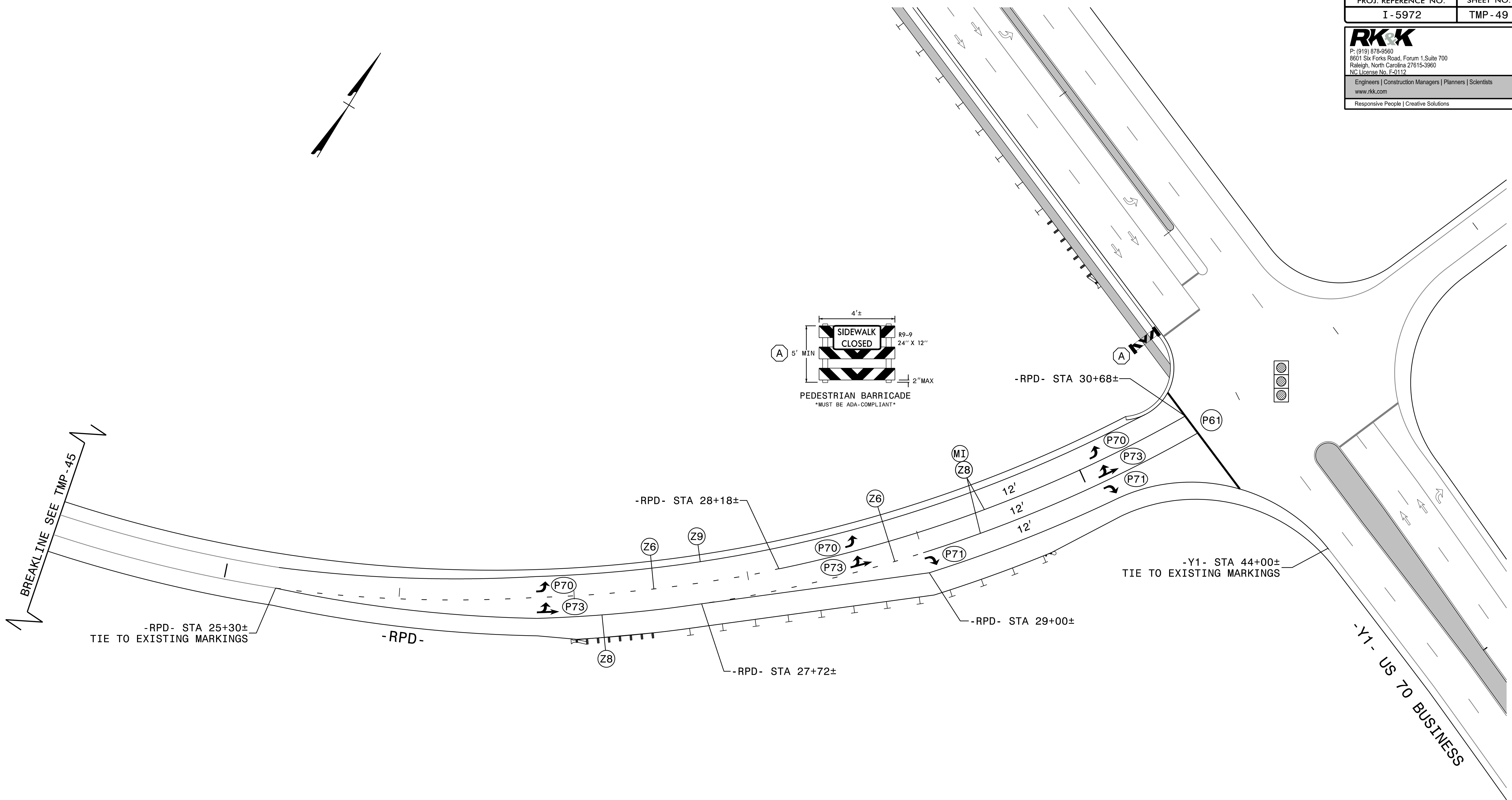

PHASE IV - STEPS 3 AND 4

**DOCUMENT NOT CONSIDERED FINAL
 UNLESS ALL SIGNATURES COMPLETED**



9/19/2023
 15912-TMP-FSH49.dgn
 R015by

| | | | |
|--|---|---|--------------------------|
| APPROVED:  DATE: 9/19/2023 SEAL |  |  | PHASE IV - STEPS 3 AND 4 |
| DOCUMENT NOT CONSIDERED FINAL UNLESS ALL SIGNATURES COMPLETED | | | |