

STATE OF NORTH CAROLINA
DIVISION OF HIGHWAYS

TRANSPORTATION MANAGEMENT PLAN

IREDELL COUNTY

DIVISION 12

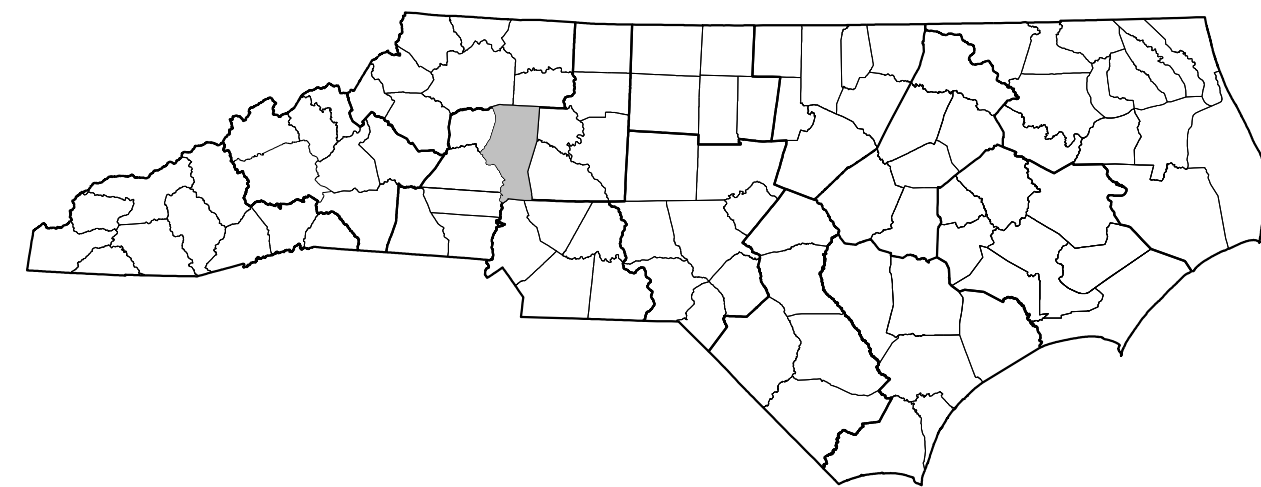

**SR 1100 BRAWLEY SCHOOL ROAD FROM
JUST EAST OF I-77 TO 1000' EAST OF US 21**

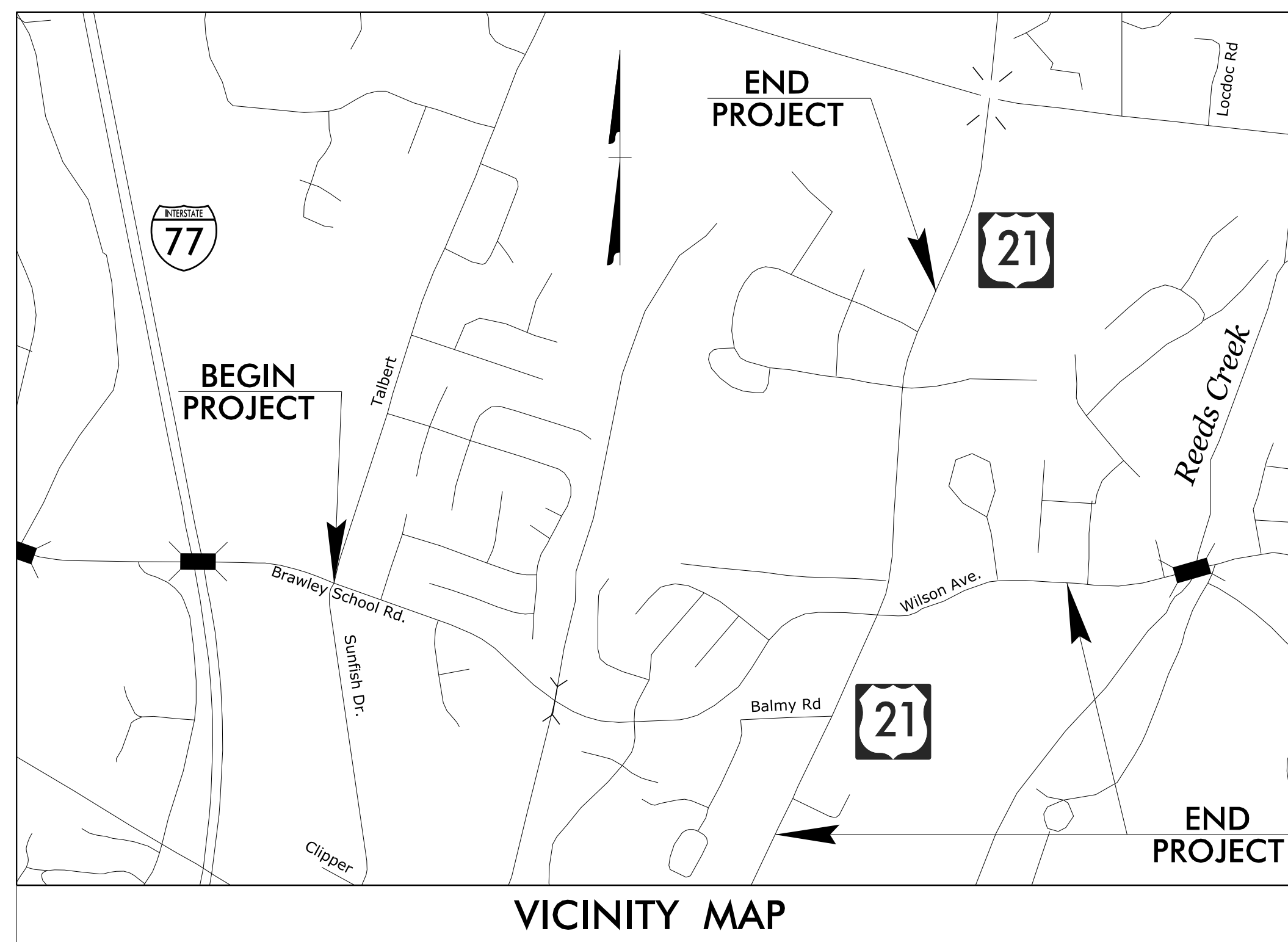

VICINITY MAP

INDEX OF SHEETS

SHEET NO.	TITLE
TMP-1	TITLE SHEET, VICINITY MAP, AND INDEX OF SHEETS
TMP-1A	LIST OF APPLICABLE ROADWAY STANDARD DRAWINGS, AND LEGEND
TMP-1B, 1C	GENERAL NOTES
TMP-2	PORTABLE CONCRETE BARRIER AT TEMPORARY SHORING LOCATIONS
TMP-2A	TEMPORARY SHORING NOTES
TMP-3	TEMPORARY TRAFFIC CONTROL PHASING
TMP-4-11	SR 1100 BRAWLEY SCHOOL ROAD -L- PHASE I STEP 1
TMP-12	SR 1100 BRAWLEY SCHOOL ROAD -L- PHASE I STEP 2,3,4
TMP-12A	-L- WILSON AVENUE DETOUR ROUTE
TMP-13	SR 1100 BRAWLEY SCHOOL ROAD -L- PHASE I STEP 3,4
TMP-14-16	SR 1100 BRAWLEY SCHOOL ROAD -L- PHASE II STEP 2
TMP-17	SR 1100 BRAWLEY SCHOOL ROAD -L- PHASE II STEP 1,2,3
TMP-18	SR 1100 BRAWLEY SCHOOL ROAD -L- PHASE II STEP 5
TMP-19-21	SR 1100 BRAWLEY SCHOOL ROAD -L- PHASE II STEP 2
TMP-22	SR 1100 BRAWLEY SCHOOL ROAD -L- PHASE II STEP 4
TMP-23-29	SR 1100 BRAWLEY SCHOOL ROAD -L- PHASE III STEP 1
TMP-30	SR 1100 BRAWLEY SCHOOL ROAD -L- PHASE III STEP 2

SHEET NO.
TMP-1

5/1/2023
L:\Traffic\Transportation Management\Plan\TCP\PLAN SHEETS\IR-3833C-TMP_01-TITLE.dgn
angood

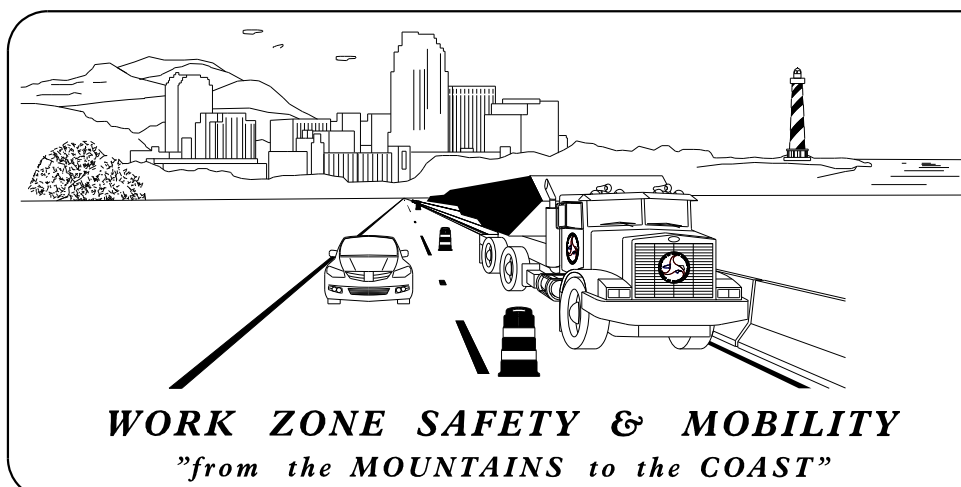

PLANS PREPARED BY:

J. W. WOOLARD, P.E.
SENIOR TRANSPORTATION ENGINEER

ANDREW N. GOOD
TRANSPORTATION DESIGNER

NCDOT DIVISION 12 CONTACTS:

BRYAN SOWELL, P.E.
PROJECT MANAGER



DOCUMENT NOT CONSIDERED FINAL
UNLESS ALL SIGNATURES COMPLETED

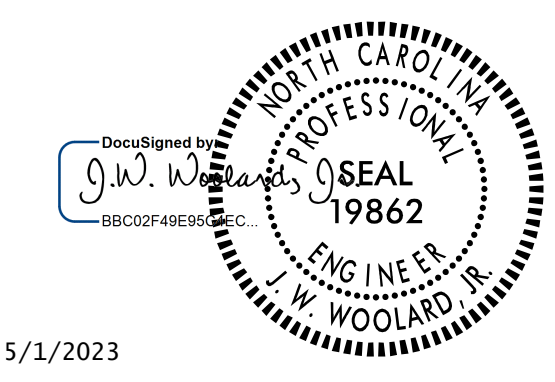

5/1/2023

TIP PROJECT: R-3833C

ROADWAY STANDARD DRAWINGS

THE FOLLOWING ROADWAY STANDARDS AS APPEAR IN "ROADWAY STANDARD DRAWINGS" - N.C. DEPARTMENT OF TRANSPORTATION - RALEIGH, N.C., DATED JANUARY 2018 ARE APPLICABLE TO THIS PROJECT AND BY REFERENCE HEREBY ARE CONSIDERED A PART OF THESE PLANS:

DIVISION 11 - WORK ZONE TRAFFIC CONTROL

STD. NO.	TITLE
1101.01	WORK ZONE ADVANCE WARNING SIGNS
1101.02	TEMPORARY LANE CLOSURES
1101.03	TEMPORARY ROAD CLOSURES
1101.04	TEMPORARY SHOULDER CLOSURES
1101.05	WORK ZONE VEHICLE ACCESSES
1101.11	TRAFFIC CONTROL DESIGN TABLES
1110.01	STATIONARY WORK ZONE SIGNS
1110.02	PORTABLE WORK ZONE SIGNS
1115.01	FLASHING ARROW BOARDS
1130.01	DRUMS
1135.01	CONES
1145.01	BARRICADES
1150.01	FLAGGING DEVICES
1160.01	TEMPORARY CRASH CUSHION
1165.01	TRUCK MOUNTED ATTENUATOR
1170.01	PORTABLE CONCRETE BARRIER
1180.01	SKINNY - DRUM

DIVISION 12 - PAVEMENT MARKINGS, MARKERS AND DELINEATORS

1205.01	PAVEMENT MARKINGS - LINE TYPES AND OFFSETS
1205.02	PAVEMENT MARKINGS - DIVIDED AND UNDIVIDED ROADWAYS
1205.04	PAVEMENT MARKINGS - INTERSECTIONS
1205.05	PAVEMENT MARKINGS - TURN LANES
1205.06	PAVEMENT MARKINGS - THRU LANE DROPS
1205.08	PAVEMENT MARKINGS - SYMOBOLS AND WORD MESSAGES
1205.09	PAVEMENT MARKINGS - PAINTED ISLANDS
1205.15	PAVEMENT MARKINGS - SUPERSTREETS
1250.01	PAVEMENT MARKER SPACING
1251.01	RAISED PAVEMENT MARKERS - PERMANENT AND TEMPORARY

PAVEMENT MARKING SCHEDULE

PAINT PAVEMENT MARKING LINES (4")	PAINT PAVEMENT MARKING LINES (24")
(P1) WHITE EDGELINE	(P61) WHITE STOPBAR
(P2) WHITE SOLID LANE LINE	
(P3) 10 FT. WHITE SKIP	PAINT PAVEMENT MARKING SYMBOLS
(P4) 3 FT. - 9 FT./SP WHITE MINISKIP	(P70) LEFT TURN ARROW
(P5) 2 FT. - 6 FT./SP WHITE MINISKIP	(P71) RIGHT TURN ARROW
(P10) YELLOW EDGELINE	(P72) STRAIGHT ARROW
(P11) YELLOW SINGLE CENTER	(P74) COMBO. RIGHT/STRAIGHT ARROW
(P12) 10 FT. YELLOW SKIP	(P76) COMBO LEFT/RIGHT/STRAIGHT ARROW
(P13) YELLOW DOUBLE CENTER	(P77) U-TURN ARROW
(P14) 2 FT. - 6 FT./SP YELLOW MINISKIP	(P78) COMBO LEFT/U-TURN ARROW
	(P79) MERGE ARROW
PAINT PAVEMENT MARKING LINES (8")	(P100) ALPHANUMERIC CHAR
(P40) WHITE GORELINE	
(P41) WHITE DIAGONAL	
(P42) YELLOW DIAGONAL	
(P43) WHITE SOLID LANE LINE	
(P44) 3 FT. - 9 FT./SP WHITE MINISKIP	
(P46) WHITE CROSSWALK LINE	

LEGEND

GENERAL

	DIRECTION OF TRAFFIC FLOW
	EXIST. PVMT.
	PROPOSED PVMT.
	NORTH ARROW
	TEMP. SHORING (LOCATION PURPOSES ONLY)
	WORK AREA
	PREVIOUSLY STARTED / CONCURRENT CONSTRUCTION
	PAVEMENT REMOVAL
	TEMPORARY PAVEMENT

PAVEMENT MARKINGS

TEMPORARY MARKINGS	EXISTING LINES	PREVIOUSLY PLACED
		WHITE EDGE LINE
		YELLOW EDGE LINE
		BROKEN LANE LINES
		MINISKIP LANE LINES
		DOUBLE YELLOW LINES
		GORELINE
		STOP BAR

PAVEMENT MARKING SYMBOLS

	EXISTING PAVEMENT MARKING SYMBOLS (HOLLOW)
	TEMPORARY SYMBOLS
	PREVIOUSLY PLACED
	ONLY
	ONLY
	ONLY
	ONLY
	ONLY

TRAFFIC CONTROL DEVICES

TEMPORARY DEVICES	PREVIOUSLY PLACED	
		BARRICADE (TYPE III)
		CONE
		DRUM
		FLASHING ARROW BOARD
		FLAGGER
		LAW ENFORCEMENT
		TRUCK MOUNTED ATTENUATOR (TMA)
		CHANGEABLE MESSAGE SIGN
		TEMPORARY CRASH CUSHION
		PORTABLE CONCRETE BARRIER

SIGNALS

	EXISTING
	PROPOSED
	TEMPORARY

TEMPORARY SIGNING

TEMPORARY SIGNS	PREVIOUSLY PLACED	
		PORTABLE SIGN
		STATIONARY SIGN
		STATIONARY OR PORTABLE SIGN

PAVEMENT MARKERS

	CRYSTAL/CRYSTAL
	CRYSTAL/RED
	YELLOW/YELLOW

5/25/2023
U:\Traffic\Transportation Management\Plan\TCP\PLAN SHEETS\IR-3833C_TMP_01A_RDWYSTDSLEGEND.dgn
angood

Stantec Consulting Services Inc.
801 Jones Franklin Road
Suite 300
Raleigh, NC 27606
Tel. 919.851.6866
Fax. 919.851.7024
www.stantec.com
License No. F-0672

5/25/2023

DOCUMENT NOT CONSIDERED FINAL
UNLESS ALL SIGNATURES COMPLETED

DIVISION OF HIGHWAYS
DEPARTMENT OF TRANSPORTATION
WORK ZONE TRAFFIC CONTROL

ROADWAY STANDARD
DRAWINGS,
AND LEGEND

MANAGEMENT STRATEGIES

PROPOSED IMPROVEMENTS ALONG BRAWLEY SCHOOL ROAD AND ALL OTHER SIDE STREETS WILL BE CONSTRUCTED WHILE MAINTAINING TRAFFIC AND USING TEMPORARY TRAFFIC PATTERNS AND TEMPORARY LANE CLOSURES. LOCAL ACCESS TO RESIDENTS AND BUSINESSES, INCLUDING PARKING, WILL BE MAINTAINED AT ALL POSSIBLE TIMES DURING CONSTRUCTION.

GENERAL NOTES

CHANGES MAY BE REQUIRED WHEN PHYSICAL DIMENSIONS IN THE DETAIL DRAWINGS, STANDARD DETAILS, AND ROADWAY DETAILS ARE NOT ATTAINABLE TO MEET FIELD CONDITIONS OR RESULT IN DUPLICATE OR UNDESIRED OVERLAPPING OF DEVICES. MODIFICATION MAY INCLUDE: MOVING, SUPPLEMENTING, COVERING, OR REMOVAL OF DEVICES AS DIRECTED BY THE ENGINEER.

THE FOLLOWING GENERAL NOTES APPLY AT ALL TIMES FOR THE DURATION OF THE CONSTRUCTION PROJECT EXCEPT WHEN OTHERWISE NOTED IN THE PLAN OR DIRECTED BY THE ENGINEER.

TIME RESTRICTIONS

A) DO NOT CLOSE OR NARROW TRAVEL LANES AS FOLLOWS:

ROAD NAME	DAY AND TIME RESTRICTIONS
ALL ROADS	6:00 A.M.-9:00 A.M. MONDAY THRU FRIDAY 4:00 P.M.-7:00 P.M. MONDAY THRU FRIDAY

GENERAL NOTES

B) DO NOT CLOSE OR NARROW TRAVEL LANES DURING HOLIDAYS AND SPECIAL EVENTS AS FOLLOWS:

- | ROAD NAME | HOLIDAY |
|-----------|---------|
| ALL ROADS | |
- FOR ANY UNEXPECTED OCCURRENCE THAT CREATES UNUSUALLY HIGH TRAFFIC VOLUMES, AS DIRECTED BY THE ENGINEER.
 - FOR NEW YEAR'S, BETWEEN THE HOURS OF 6:00 A.M. DECEMBER 31ST TO 7:00 P.M. JANUARY 2ND. IF NEW YEAR'S DAY IS ON A FRIDAY, SATURDAY, SUNDAY, OR MONDAY THEN UNTIL 7:00 P.M. THE FOLLOWING TUESDAY.
 - FOR EASTER, BETWEEN THE HOURS OF 6:00 A.M. THURSDAY AND 7:00 P.M. MONDAY.
 - FOR MEMORIAL DAY, BETWEEN THE HOURS OF 6:00 A.M. FRIDAY TO 7:00 P.M. TUESDAY.
 - FOR INDEPENDENCE DAY, BETWEEN THE HOURS OF 6:00 A.M. THE DAY BEFORE INDEPENDENCE DAY AND 7:00 P.M. THE DAY AFTER INDEPENDENCE DAY. IF INDEPENDENCE DAY IS ON A FRIDAY, SATURDAY, SUNDAY OR MONDAY; THEN BETWEEN THE HOURS OF 6:00 A.M. THE THURSDAY BEFORE INDEPENDENCE DAY AND 7:00 P.M. THE TUESDAY AFTER INDEPENDENCE DAY.
 - FOR LABOR DAY, BETWEEN THE HOURS OF 6:00 A.M. FRIDAY AND 7:00 P.M. TUESDAY.
 - FOR THANKSGIVING DAY, BETWEEN THE HOURS OF 6:00 A.M. TUESDAY TO 7:00 P.M. MONDAY.
 - FOR CHRISTMAS, BETWEEN THE HOURS OF 6:00 A.M. THE FRIDAY BEFORE THE WEEK OF CHRISTMAS DAY AND 7:00 P.M. THE FOLLOWING TUESDAY AFTER THE WEEK OF CHRISTMAS.
 - FOR ANY RACES OR EVENTS AT CHARLOTTE MOTOR SPEEDWAY THAT CREATE UNUSUALLY HIGH TRAFFIC VOLUMES, AS DIRECTED BY THE ENGINEER.
 - FOR NORTH CAROLINA RACE WEEK, BETWEEN THE HOURS OF 6:00 AM SATURDAY AND 6:00 PM THE FOLLOWING SUNDAY
- C) DO NOT CONDUCT ANY HAULING OPERATIONS AGAINST THE FLOW OF TRAFFIC OF AN OPEN TRAVELWAY UNLESS THE HAULING OPERATION IS PROTECTED BY BARRIER OR GUARDRAIL OR AS DIRECTED BY THE ENGINEER.

LANE AND SHOULDER CLOSURE REQUIREMENTS

- REMOVE LANE CLOSURE DEVICES FROM THE LANE WHEN WORK IS NOT BEING PERFORMED BEHIND THE LANE CLOSURE OR WHEN A LANE CLOSURE IS NO LONGER NEEDED OR AS DIRECTED BY THE ENGINEER.
- WHEN PERSONNEL AND/OR EQUIPMENT ARE WORKING WITHIN 15 FT OF AN OPEN TRAVEL LANE, CLOSE THE NEAREST OPEN SHOULDER USING ROADWAY STANDARD DRAWING NO. 1101.04 UNLESS THE WORK AREA IS PROTECTED BY BARRIER OR GUARDRAIL OR A LANE CLOSURE IS INSTALLED.
- WHEN PERSONNEL AND/OR EQUIPMENT ARE WORKING ON THE SHOULDER ADJACENT TO AN UNDIVIDED FACILITY AND WITHIN 5 FT OF AN OPEN TRAVEL LANE, CLOSE THE NEAREST OPEN TRAVEL LANE USING ROADWAY STANDARD DRAWING NO. 1101.02 UNLESS THE WORK AREA IS PROTECTED BY BARRIER OR GUARDRAIL.
- WHEN PERSONNEL AND/OR EQUIPMENT ARE WORKING ON THE SHOULDER ADJACENT TO A DIVIDED FACILITY AND WITHIN 10 FT OF AN OPEN TRAVEL LANE, CLOSE THE NEAREST OPEN TRAVEL LANE USING ROADWAY STANDARD DRAWING NO. 1101.02 UNLESS THE WORK AREA IS PROTECTED BY BARRIER OR GUARDRAIL.
- WHEN PERSONNEL AND/OR EQUIPMENT ARE WORKING WITHIN A LANE OF TRAVEL OF AN UNDIVIDED OR DIVIDED FACILITY, CLOSE THE LANE ACCORDING TO THE TRANSPORTATION MANAGEMENT PLANS, ROADWAY STANDARD DRAWINGS, OR AS DIRECTED BY THE ENGINEER. CONDUCT THE WORK SO THAT ALL PERSONNEL AND/OR EQUIPMENT REMAIN WITHIN THE CLOSED TRAVEL LANE.
- DO NOT WORK SIMULTANEOUSLY WITHIN 15 FT ON BOTH SIDES OF AN OPEN TRAVELWAY, RAMP, OR LOOP WITHIN THE SAME LOCATION UNLESS PROTECTED WITH GUARDRAIL OR BARRIER.

PAVEMENT EDGE DROP OFF REQUIREMENTS

- BACKFILL AT A 6:1 SLOPE UP TO THE EDGE AND ELEVATION OF EXISTING PAVEMENT IN AREAS ADJACENT TO AN OPEN TRAVEL LANE THAT HAS A DROP-OFF AS FOLLOWS:

BACKFILL DROP-OFFS THAT EXCEED 2 INCHES ON ROADWAYS WITH POSTED SPEED LIMITS OF 45 MPH OR GREATER.

BACKFILL DROP-OFFS THAT EXCEED 3 INCHES ON ROADWAYS WITH POSTED SPEED LIMITS LESS THAN 45 MPH.

BACKFILL WITH SUITABLE COMPACTED MATERIAL, AS APPROVED BY THE ENGINEER, AT NO EXPENSE TO THE DEPARTMENT.
- DO NOT EXCEED A DIFFERENCE OF 2 INCHES IN ELEVATION BETWEEN OPEN LANES OF TRAFFIC FOR NOMINAL LIFTS OF 1.5 INCHES. INSTALL ADVANCE WARNING "UNEVEN LANES" SIGNS (W8-11) 500 FT IN ADVANCE AND A MINIMUM OF ONCE EVERY HALF MILE THROUGHOUT THE UNEVEN AREA.

8/29/2023
L:\Traffic\Transportation Management\Plan\TCP\PLAN SHEETS\IR-3833C-TMP_01B_GENERALNOTES.dgn
angood

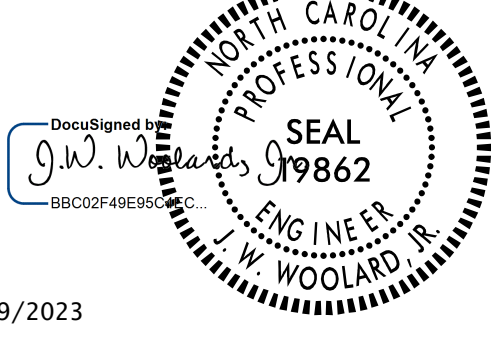
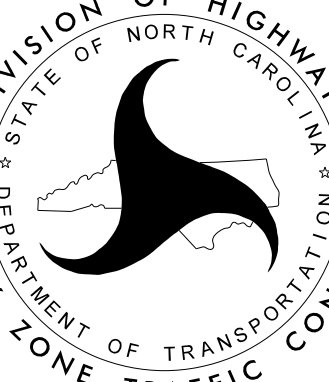
 <p>Stantec Consulting Services Inc. 801 Jones Franklin Road Suite 300 Raleigh, NC 27606 Tel. 919.851.6866 Fax. 919.851.7024 www.stantec.com License No. F-0672</p>	<p>DocuSigned by: <i>J.W. Woolard</i> 8/29/2023</p>  <p>DOCUMENT NOT CONSIDERED FINAL UNLESS ALL SIGNATURES COMPLETED</p>		<p>GENERAL NOTES</p>
--	--	---	----------------------

GENERAL NOTES

TRAFFIC PATTERN ALTERATIONS

K) NOTIFY THE ENGINEER THIRTY (30) CALENDAR DAYS PRIOR TO ANY TRAFFIC PATTERN ALTERATION.

SIGNING

L) INSTALL ADVANCE WORK ZONE WARNING SIGNS WHEN WORK IS WITHIN 40 FT FROM THE EDGE OF TRAVEL LANE AND NO MORE THAN THREE (3) DAYS PRIOR TO THE BEGINNING OF CONSTRUCTION.

M) PROVIDE SIGNING AND DEVICES REQUIRED TO CLOSE THE ROAD ACCORDING TO THE ROADWAY STANDARD DRAWINGS AND TRANSPORTATION MANAGEMENT PLANS.

AND

PROVIDE SIGNING REQUIRED FOR THE OFF-SITE DETOUR ROUTE AS SHOWN IN THE TRANSPORTATION MANAGEMENT PLANS.

N) ENSURE ALL NECESSARY SIGNING IS IN PLACE PRIOR TO ALTERING ANY TRAFFIC PATTERN.

O) INSTALL BLACK ON ORANGE "DIP" SIGNS (W8-2) AND/OR "BUMP" SIGNS (W8-1) 500 FT IN ADVANCE OF THE UNEVEN AREA, OR AS DIRECTED BY THE ENGINEER.

P) COVER OR REMOVE ALL SIGNS AND DEVICES REQUIRED TO CLOSE THE ROAD WHEN ROAD CLOSURE IS NOT IN OPERATION.

AND

COVER OR REMOVE ALL SIGNS REQUIRED FOR THE OFF-SITE DETOUR WHEN THE DETOUR IS NOT IN OPERATION.

TRAFFIC BARRIER

Q) INSTALL TEMPORARY BARRIER ACCORDING TO THE TRANSPORTATION MANAGEMENT PLANS A MAXIMUM OF TWO (2) WEEKS PRIOR TO BEGINNING WORK IN ANY LOCATION. ONCE TEMPORARY BARRIER IS INSTALLED AT ANY LOCATION PROCEED IN A CONTINUOUS MANNER TO COMPLETE THE PROPOSED WORK IN THAT LOCATION UNLESS OTHERWISE STATED IN THE TRANSPORTATION MANAGEMENT PLANS OR AS DIRECTED BY THE ENGINEER.

DO NOT PLACE BARRIER DIRECTLY ON ANY SURFACE OTHER THAN ASPHALT OR CONCRETE.

ONCE TEMPORARY BARRIER IS INSTALLED AT ANY LOCATION AND NO WORK IS PERFORMED BEHIND THE TEMPORARY BARRIER FOR A PERIOD LONGER THAN TWO (2) MONTHS, REMOVE/RESET TEMPORARY BARRIER AT NO COST TO THE DEPARTMENT UNLESS OTHERWISE STATED IN THE TRANSPORTATION MANAGEMENT PLANS, TEMPORARY BARRIER IS PROTECTING A HAZARD, OR AS DIRECTED BY THE ENGINEER.

INSTALL TEMPORARY BARRIER WITH THE TRAFFIC FLOW BEGINNING WITH THE UPSTREAM SIDE OF TRAFFIC. REMOVE TEMPORARY BARRIER AGAINST THE TRAFFIC FLOW BEGINNING WITH THE DOWNSTREAM SIDE OF TRAFFIC.

INSTALL AND SPACE DRUMS NO GREATER THAN TWICE THE POSTED SPEED LIMIT (MPH) TO CLOSE OR KEEP THE SECTION OF THE ROADWAY CLOSED UNTIL THE TEMPORARY BARRIER CAN BE PLACED OR AFTER THE TEMPORARY BARRIER IS REMOVED.

R) PROTECT THE APPROACH END OF MOVABLE/PORTABLE CONCRETE BARRIER AT ALL TIMES DURING THE INSTALLATION AND REMOVAL OF THE BARRIER BY EITHER A TRUCK MOUNTED ATTENUATOR (MAXIMUM 72 HOURS) OR A TEMPORARY CRASH CUSHION.

PROTECT THE APPROACH END OF MOVABLE/PORTABLE CONCRETE BARRIER FROM ONCOMING TRAFFIC AT ALL TIMES BY A TEMPORARY CRASH CUSHION UNLESS THE APPROACH END OF MOVABLE/PORTABLE CONCRETE BARRIER IS OFFSET FROM ONCOMING TRAFFIC AS FOLLOWS OR AS SHOWN IN THE PLANS:

POSTED SPEED LIMIT	MINIMUM OFFSET
40 OR LESS	15 FT
45-50	20 FT
55	25 FT
60 MPH or HIGHER	30 FT

TRAFFIC CONTROL DEVICES

S) WHEN LANE CLOSURES ARE NOT IN EFFECT SPACE CHANNELIZING DEVICES IN WORK AREAS NO GREATER IN FEET THAN TWICE THE POSTED SPEED LIMIT (MPH), EXCEPT 10 FT ON-CENTER IN RADII, AND 3 FT OFF THE EDGE OF AN OPEN TRAVELWAY. REFER TO STANDARD SPECIFICATIONS FOR ROADS AND STRUCTURES SECTIONS 1130 (DRUMS), 1135 (CONES) AND 1180 (SKINNY DRUMS) FOR ADDITIONAL REQUIREMENTS.

T) PLACE TYPE III BARRICADES WITH "ROAD CLOSED" SIGN R11-2 ATTACHED, OF SUFFICIENT LENGTH TO CLOSE ENTIRE ROADWAY.

U) PLACE ADDITIONAL SETS OF THREE CHANNELIZING DEVICES (DRUMS, CONES OR SKINNY DRUMS) PERPENDICULAR TO THE EDGE OF TRAVELWAY ON (500 FT) CENTERS WHEN UNOPENED LANES ARE CLOSED TO TRAFFIC.

PAVEMENT MARKINGS AND MARKERS

V) INSTALL TEMPORARY PAVEMENT MARKINGS AND TEMPORARY PAVEMENT MARKERS ON INTERIM LAYERS OF PAVEMENT AS FOLLOWS:

ROAD NAME	MARKING	MARKER
ALL ROADS	PAINT	TEMPORARY RAISED

W) PLACE ONE APPLICATION OF PAINT FOR TEMPORARY TRAFFIC PATTERNS. PLACE A SECOND APPLICATION OF PAINT SIX (6) MONTHS AFTER THE INITIAL APPLICATION AND EVERY SIX MONTHS AS DIRECTED BY THE ENGINEER.

X) TIE PROPOSED PAVEMENT MARKING LINES TO EXISTING PAVEMENT MARKING LINES.

Y) REMOVE/REPLACE ANY CONFLICTING/DAMAGED PAVEMENT MARKINGS AND MARKERS BY THE END OF EACH DAY'S OPERATION.

MISCELLANEOUS

Z) USE LAW ENFORCEMENT TO MAINTAIN TRAFFIC THROUGH THE WORK AREA AND OR INTERSECTIONS AS SHOWN IN PLANS OR DIRECTED BY THE ENGINEER.

AA) ALL CURB RAMP LOCATIONS SHALL BE DERIVED FROM STATIONING SHOWN ON PAVEMENT MARKING PLANS OR AS DIRECTED BY THE ENGINEER IN COORDINATION WITH THE SIGNING AND DELINEATION UNIT.

BB) USE ADA COMPLIANT PEDESTRIAN CHANNELIZING DEVICES TO KEEP SIDEWALKS CLOSED UNTIL THEIR IS CONTINUNUITY.

CC) CONTRACTOR SHALL MAINTAIN SIDEWALK ACCESS AT ALL TIMES AS STATED IN THE PHASING. CONTRACTOR SHALL BE RESPONSIBLE TO PROVIDE TEMPORARY SIDEWALKS (CONCRETE, ASPHALT, OR OTHER SUITABLE MATERIAL AS APPROVED BY THE ENGINEER) AT ALL LOCATIONS WHERE THE OPEN PEDESTRIAN TRAVELWAY HAS BEEN REMOVED FOR CONSTRUCTION OPERATIONS (UTILITIES, DRAINAGE, ETC.).

DD) MAINTAIN VEHICULAR ACCESS TO ALL DRIVEWAYS DURING THE LIFE OF THE CONTRACT, UNLESS OTHERWISE NOTED IN THE PHASING OR DIRECTED BY THE ENGINEER. USE INCIDENTAL STONE WHEN NECESSARY.

EE) ALL DIMENSIONS AND STATIONS IN THE TRANSPORTATION MANAGEMENT PLAN AND PHASING ARE APPROXIMATE (+/-); FIELD ADJUST AS NECESSARY OR AS DIRECTED BY THE ENGINEER.

FF) USE LAW ENFORCEMENT TO DIRECT TRAFFIC AND ENFORCE ROAD CLOSURES. LOCATIONS SHOWN IN THE PLANS ARE APPROXIMATE AND MAY BE REVISED AS THE OFFICER OR THE ENGINEER DEEM NECESSARY.

GG) CHANGEABLE MESSAGE SIGN MESSAGES SHOWN ARE EXAMPLES. OTHER MESSAGES MAY BE USED AS CONDITIONS WARRANT. ALL MESSAGES AND LOCATIONS MUST BE APPROVED BY THE ENGINEER PRIOR TO INCORPORATING.

HH) COMPLETE ANY PROPOSED OR TEMPORARY WIDENING IN SUCH A MANNER THAT PONDING OF WATER WILL NOT OCCUR IN THE TRAVEL LANE.

II) MAINTAIN EXISTING GUARDRAIL UNTIL PROPOSED FILL SLOPES ARE COMPLETED TO THE POINT THAT FIELD CONDITIONS NO LONGER MEET GUARDRAIL WARRANTS AS DIRECTED BY THE ENGINEER.

JJ) MAINTAIN ALL EXISTING SIGNING ON PROJECT (WARNING, REGULATORY AND GUIDE SIGNS). WHERE CONSTRUCTION AFFECTS THE LOCATION OF A SIGN, RELOCATE AS NECESSARY, OR INSTALL REPLACEMENT SUCH THAT THE FUNCTION OF THE SIGN IS MAINTAINED AT ALL TIMES. DURING RELOCATION OF STOP SIGNS PROVIDE FLAGGERS WITH "FLAGGER AHEAD" (W20-7a) AND "BE PREPARED TO STOP" (W3-4) SIGNS AS NECESSARY TO MAINTAIN INTERSECTION TRAFFIC.

KK) DRAINAGE CONSTRUCTION SHOWN IN THE TRANSPORTATION MANAGEMENT PLAN IS A GENERAL REPRESENTATION OF WORK TO BE PERFORMED DURING A PARTICULAR PHASE OF CONSTRUCTION. REFER TO THE ROADWAY PLANS FOR DRAINAGE ITEMS. IN THE EVENT THERE IS A DISCREPANCY BETWEEN WHAT IS SHOWN IN THE TRANSPORTATION MANAGEMENT PLAN AND THE ROADWAY PLAN, THE ROADWAY PLAN SHALL GOVERN OVER THE TRANSPORTATION MANAGEMENT PLAN.

5/24/2023 5:\Traffic\Transportation Management Plan\TCP\PLAN SHEETS\VR-3833C-TMP_01C_GENERALNOTES.dgn angood

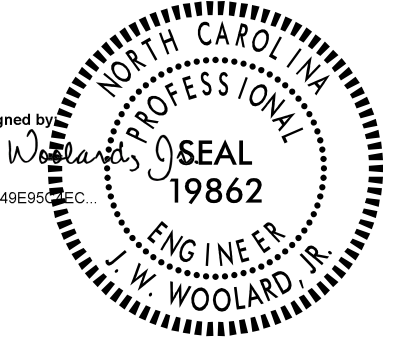
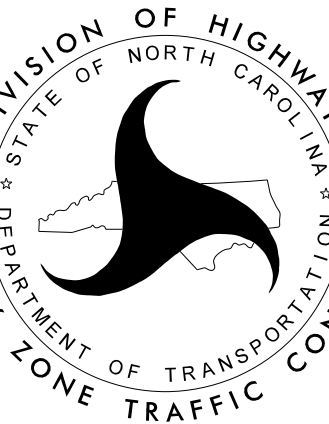
 <p>Stantec Consulting Services Inc. 801 Jones Franklin Road Suite 300 Raleigh, NC 27606 Tel. 919.851.6866 Fax. 919.851.7024 www.stantec.com License No. F-0672</p>	<p>DocuSigned by: J.W. Woolard 5/24/2023</p>  <p>DOCUMENT NOT CONSIDERED FINAL UNLESS ALL SIGNATURES COMPLETED</p>		<p style="text-align: center; font-weight: bold;">GENERAL NOTES</p>
--	--	---	---

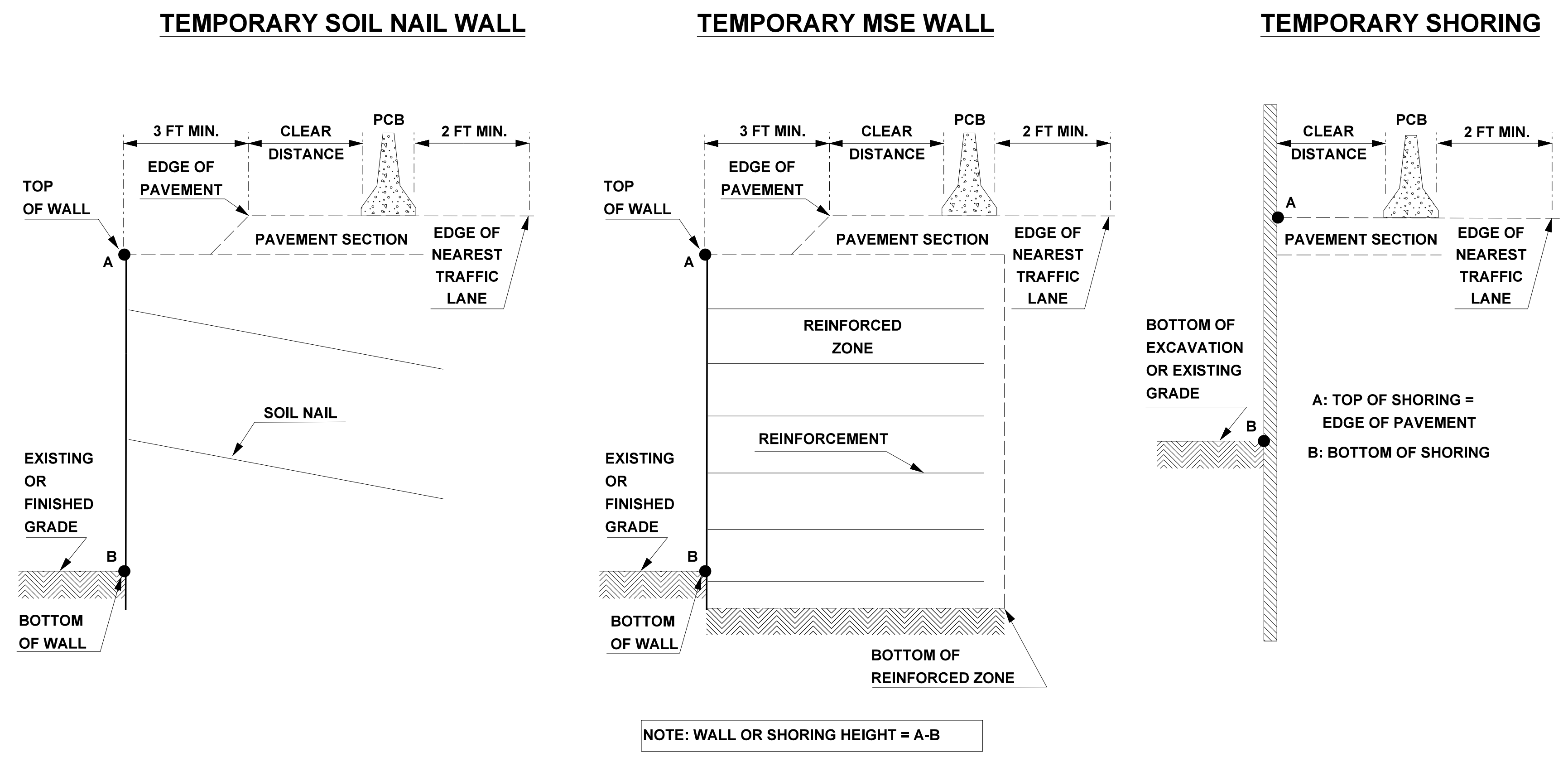

FIGURE A

NOTES

- 1- REFER TO THE TRAFFIC CONTROL PLANS FOR TEMPORARY SHORING LOCATIONS AND NOTES.
- 2- REFER TO THE "TEMPORARY SHORING" STANDARD PROVISION FOR INFORMATION ABOUT TEMPORARY SHORING AND PORTABLE CONCRETE BARRIER (PCB).
- 3- PCB IS REQUIRED IF TEMPORARY SHORING/WALL IS LOCATED WITHIN THE CLEAR ZONE IN ACCORDANCE WITH THE AASHTO ROADSIDE DESIGN GUIDE. DO NOT PLACE BARRIER DIRECTLY ON ANY SURFACE OTHER THAN ASPHALT OR CONCRETE. (CONTACT NCDOT PAVEMENT MANAGEMENT FOR APPLICABLE PAVEMENT DESIGN).
- 4- BASED ON THE CLEAR DISTANCE, OFFSET, DESIGN SPEED AND PAVEMENT TYPE, CHOOSE AN UNANCHORED OR ANCHORED PCB FROM THE TABLE SHOWN IN FIGURE B. CLEAR DISTANCE IS DEFINED AS SHOWN IN FIGURE A AND OFFSET IS DEFINED AS SHOWN IN FIGURE B.
- 5- AT THE CONTRACTOR'S OPTION OR IF THE MINIMUM REQUIRED CLEAR DISTANCE IS NOT AVAILABLE, SET PCB NEXT TO AND UP AGAINST THE TRAFFIC SIDE OF THE TEMPORARY SHORING/WALLS EXCEPT FOR BARRIER ABOVE TEMPORARY WALLS. PCB WITH THE MINIMUM REQUIRED CLEAR DISTANCE IS REQUIRED ABOVE TEMPORARY WALLS.
- 6- USE NCDOT PORTABLE CONCRETE BARRIER (PCB) IN ACCORDANCE WITH ROADWAY STANDARD DRAWING NO. 1170.01 AND SECTION 1170 OF THE STANDARD SPECIFICATIONS.
- 7- SET PCB WITH A MINIMUM HORIZONTAL DISTANCE OF 2 FT BETWEEN THE FRONT FACE OF THE BARRIER AND THE EDGE OF THE NEAREST TRAFFIC LANE AS SHOWN IN FIGURE A UNLESS OTHERWISE SHOWN IN THE PLANS OR APPROVED BY THE ENGINEER.
- 8- FOR PCB ABOVE AND BEHIND TEMPORARY WALLS, PROVIDE A MINIMUM DISTANCE OF 3 FT BETWEEN THE EDGE OF PAVEMENT AND THE WALL FACE AS SHOWN IN FIGURE A. IF THIS MINIMUM REQUIRED DISTANCE IS NOT AVAILABLE, CONTACT THE ENGINEER.
- 9- TABLE SHOWN IN FIGURE B IS BASED ON NCDOT RESEARCH PROJECT NO. 2005-010 WITH VEHICLE TYPE USED FOR NCHRP 350 CRASH TESTS.

MINIMUM REQUIRED CLEAR DISTANCE, inches

Barrier Type	Pavement Type	Offset * ft	Design Speed, mph					
			<30	31-40	41-50	51-60	61-70	71-80
Unanchored PCB	Asphalt	<8	24	26	29	32	36	40
		8-14	26	28	31	35	38	42
		14-20	27	29	34	36	39	43
		20-26	28	31	35	38	40	44
		26-32	29	32	36	39	42	45
		32-38	30	34	38	41	43	46
		38-44	31	34	41	43	45	48
	Concrete	44-50	31	35	41	43	46	49
		50-56	32	36	42	44	47	50
		>56	32	36	42	45	47	51
		<8	17	18	21	22	25	26
		8-14	19	20	23	25	26	29
		14-20	22	22	24	26	28	31
		20-26	23	24	26	27	30	34
Anchored PCB	Asphalt	All Offsets	24 for All Design Speeds					
		Concrete (including bridge approach slabs)	All Offsets	12 for All Design Speeds				

* See Figure Below

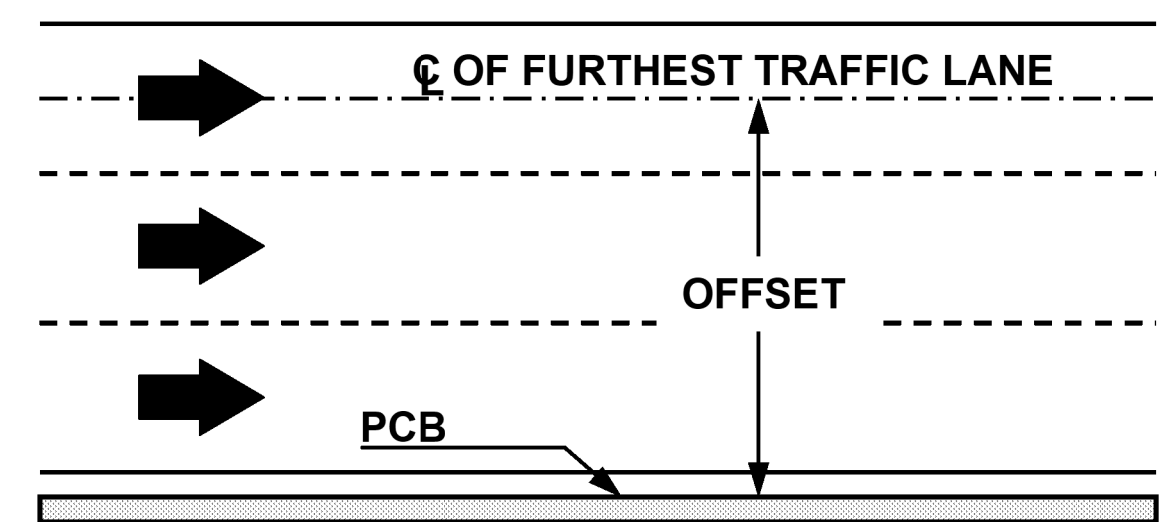
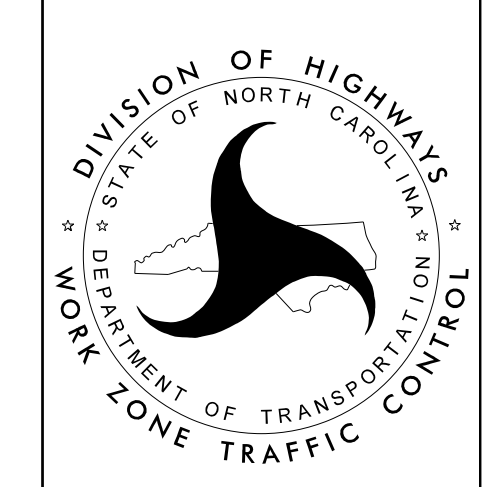

FIGURE B

DETAIL PROVIDED BY NCDOT



PORTABLE CONCRETE BARRIER AT TEMPORARY SHORING LOCATIONS

TEMPORARY SHORING LOCATION NO. 01 ESTIMATED QUANTITY = 1500.8 SF

-L- STA. 35+39, 10.5' LT TO -L- STA. 36+51, 10.5' LT
 LENGTH=112' AVERAGE HEIGHT = 13.4 FT MAXIMUM HEIGHT = 13.6 FT

- FOR TEMPORARY SHORING AND POSITIVE PROTECTION FOR TEMPORARY SHORING, SEE PLANS AND TEMPORARY SHORING PROVISION.
- BEFORE BEGINNING TEMPORARY SHORING DESIGN OR CONSTRUCTION, SURVEY EXISTING GROUND ELEVATIONS IN THE VICINITY OF SHORING LOCATIONS TO DETERMINE ACTUAL SHORING HEIGHTS.
- DESIGN TEMPORARY SHORING FROM -L- STATION 35+39, 10.5' LT TO STATION 36+51', 10.5' LT FOR THE FOLLOWING ASSUMED SOIL PARAMETERS AND GROUNDWATER ELEVATION:
 UNIT WEIGHT (γ) = 110 LB/CF
 FRICTION ANGLE (ϕ) = 26 DEGREES
 COHESION (c) = 0 LB/SF
 GROUNDWATER ELEVATION = 767 FT
- DESIGN TEMPORARY SHORING FROM -L- STATION 35+39, 10.5' LT TO STATION 36+51', 10.5 FT FOR TRAFFIC IMPACT.
- LIMITED SUBSURFACE INFORMATION IS AVAILABLE IN THE VICINITY OF TEMPORARY SHORING FROM -L- STATION 35+39, 10.5' LT TO STATION 36+51', LT. THE INFORMATION PROVIDED FOR TEMPORARY SHORING DESIGN WAS ASSUMED AND MAY NOT BE APPLICABLE TO THE ACTUAL SITE CONDITIONS ENCOUNTERED DURING CONSTRUCTION BELOW 747 FT.
- DO NOT USE ANCHORED SHORING FOR TEMPORARY SHORING FROM STATION -L- STATION 35+39, 10.5' LT TO STATION 36+51', 10.5 LT.

TEMPORARY SHORING LOCATION NO. 02 ESTIMATED QUANTITY = 468.0 SF

-L- STA. 33+00, 9.3' LT TO -L- STA. 34+17, 11.5' LT
 LENGTH=117' AVERAGE HEIGHT = 4.0 FT MAXIMUM HEIGHT = 4.7 FT

- FOR TEMPORARY SHORING AND POSITIVE PROTECTION FOR TEMPORARY SHORING, SEE PLANS AND TEMPORARY SHORING PROVISION.
- BEFORE BEGINNING TEMPORARY SHORING DESIGN OR CONSTRUCTION, SURVEY EXISTING GROUND ELEVATIONS IN THE VICINITY OF SHORING LOCATIONS TO DETERMINE ACTUAL SHORING HEIGHTS.
- DESIGN TEMPORARY SHORING FROM -L- STATION 33+00, 9.3' LT TO STATION 34+17', 11.5' RT FOR THE FOLLOWING ASSUMED SOIL PARAMETERS AND GROUNDWATER ELEVATION:
 UNIT WEIGHT (γ) = 120 LB/CF
 FRICTION ANGLE (ϕ) = 30 DEGREES
 COHESION (c) = 0 LB/SF
 GROUNDWATER ELEVATION = 767 FT

TEMPORARY SHORING LOCATION NO. 03 ESTIMATED QUANTITY = 3129.3 SF

-L- STA. 34+17, 11.5' LT TO -L- STA. 36+66, 11.5' LT
 LENGTH=549' AVERAGE HEIGHT = 5.7 FT MAXIMUM HEIGHT = 6.1 FT

- FOR TEMPORARY SHORING AND POSITIVE PROTECTION FOR TEMPORARY SHORING, SEE PLANS AND TEMPORARY SHORING PROVISION.
- BEFORE BEGINNING TEMPORARY SHORING DESIGN OR CONSTRUCTION, SURVEY EXISTING GROUND ELEVATIONS IN THE VICINITY OF SHORING LOCATIONS TO DETERMINE ACTUAL SHORING HEIGHTS.
- DESIGN TEMPORARY SHORING FROM -L- STATION 34+17, 11.5' LT TO STATION 36+66', 11.5' LT FOR THE FOLLOWING ASSUMED SOIL PARAMETERS AND GROUNDWATER ELEVATION:
 UNIT WEIGHT (γ) = 110 LB/CF
 FRICTION ANGLE (ϕ) = 26 DEGREES
 COHESION (c) = 0 LB/SF
 GROUNDWATER ELEVATION = 767 FT

TEMPORARY SHORING LOCATION NO. 04 ESTIMATED QUANTITY = 1328.7 SF

-L- STA. 36+66, 11.5' LT TO -L- STA. 39+75, 7.5' LT
 LENGTH=309' AVERAGE HEIGHT = 4.3 FT MAXIMUM HEIGHT = 6.6 FT

- FOR TEMPORARY SHORING AND POSITIVE PROTECTION FOR TEMPORARY SHORING, SEE PLANS AND TEMPORARY SHORING PROVISION.
- BEFORE BEGINNING TEMPORARY SHORING DESIGN OR CONSTRUCTION, SURVEY EXISTING GROUND ELEVATIONS IN THE VICINITY OF SHORING LOCATIONS TO DETERMINE ACTUAL SHORING HEIGHTS.
- DESIGN TEMPORARY SHORING FROM -L- STATION 36+66, 11.5' LT TO STATION 39+75', 7.5' LT FOR THE FOLLOWING ASSUMED SOIL PARAMETERS AND GROUNDWATER ELEVATION:
 UNIT WEIGHT (γ) = 110 LB/CF
 FRICTION ANGLE (ϕ) = 26 DEGREES
 COHESION (c) = 0 LB/SF
 GROUNDWATER ELEVATION = 767 FT

5/1/2023 1:24:11 PM U:\Traffic\Transportation Management Plan\TCP\PLAN SHEETS\NR-3833C-TMP_02A-TEMPORARY_SHORING_NOTES.dgn angood

THE TEMPORARY SHORING NOTES SHOWN ON THIS SHEET WERE PROVIDED THROUGH A SEALED DOCUMENT FROM THE GEOTECHNICAL ENGINEER. THE DOCUMENT WAS SUBMITTED TO STANTEC CONSULTING ON (JANUARY 7, 2022) AND SEALED BY A PROFESSIONAL ENGINEER, (JEREMY R. HAMM), LICENSE #039779.

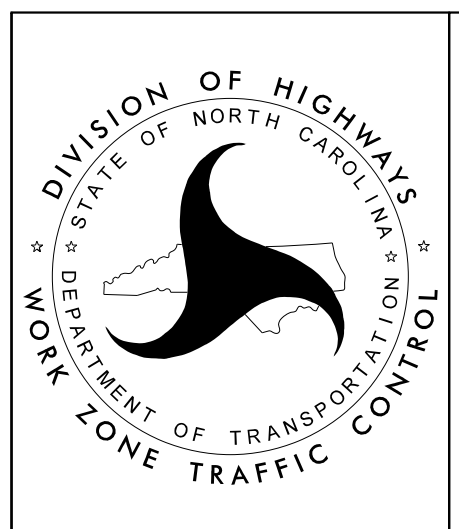

TEMPORARY SHORING NOTES

PHASING

PROJ. REFERENCE NO.	SHEET NO.
R-3833C	TMP-3

PHASE I (TMP-4 TO TMP-13)

PHASE I (TMP-4 TO TMP-13)

PRIOR TO ANY WORK OPERATIONS, INSTALL WORK ZONE ADVANCE WARNING SIGNS ON -L- AND ALL -Y- LINES PER ROADWAY STANDARD DRAWING 1101.01, SHEET 3 OF 3.

STEP 1: USING TEMPORARY LANE CLOSURES AND FLAGGING OPERATIONS PER ROADWAY STANDARD DRAWING 1101.02, SHEETS 1 AND 3 OF 14, PERFORM THE FOLLOWING:

- INSTALL FOUR (4) FEET OF TEMPORARY PAVEMENT ON -L- FROM STA. 32+00+/- LT TO STA. 40+50+/- LT AND THEN INSTALL PCB AS SHOWN ON TMP-5.
- REMOVE EXISTING PARKING LOT PAVEMENT ON LEFT SIDE OF -Y- FROM STA. 33+46+/- TO STA. 35+61+/- AS SHOWN ON TMP-7, 10.
- CONSTRUCT AWAY FROM TRAFFIC THE FOLLOWING UP TO BUT NOT INCLUDING THE FINAL LAYER OF SURFACE COURSE:
 - o LEFT SIDE OF PROPOSED -L- FROM STA. 18+37+/- TO STA. 61+84+/- AND STA. 70+32+/- TO STA. 75+83+/- (INCLUDING TEMPORARY SHORING AND CULVERT; AND EXCLUDING PROPOSED SIDEWALK FROM STA. 33+55+/- TO STA. 38+00+/-), -Y3-, -DRWY4-, AND DRIVEWAYS AS SHOWN ON TMP-4 TO TMP-8.
 - o LEFT SIDE OF PROPOSED -Y- FROM STA. 13+75+/- TO STA. 34+49+/- AND STA. 42+90+/- TO STA. 56+10+/- INCLUDING DRIVEWAYS AS SHOWN ON TMP-7, 9, 10, 11.
 - o RIGHT SIDE OF PROPOSED -Y- FROM STA. 35+01+/- TO STA. 36+86+/- AS SHOWN ON TMP-7.
- PLACE AS MUCH FILL MATERIAL AS POSSIBLE ON THE RIGHT SIDE OF PROPOSED -L- FROM STA. 62+30+/- TO STA. 75+83+/-.

STEP 2: PLACE TEMPORARY MARKINGS AND TRAFFIC CONTROL DEVICES ON -Y- AS SHOWN ON TMP-12 AND SHIFT TO THE TEMPORARY PATTERN.

ICT: COMPLETE PHASE I, STEP 3 TO STEP 5 IN 180 CONSECUTIVE CALENDAR DAYS. (SEE SPECIAL PROVISIONS)

STEP 3: PLACE OFF-SITE DETOUR SIGNS FOR -L- (WILSON AVE.) USING TMP-12A AND ROADWAY STANDARD DRAWING 1101.03, SHEET 2 OF 9. CLOSE -L- TO TRAFFIC AND PLACE TRAFFIC ON THE OFF-SITE DETOUR SHOWN ON TMP-12A.

STEP 4: REMOVE PAVEMENT FROM -L- STA. 65+75+/- TO STA. 70+52+/- AS SHOWN ON TMP-12, 13.

CONSTRUCT -L- (WILSON AVE.) UP TO BUT NOT INCLUDING THE FINAL LAYER OF SURFACE COURSE FROM STA. 62+02+/- TO STA. 75+83+/- AND -Y- STA. 34+49+/- TO STA. 49+90+/-; INCLUDING -DRWY3-DRWY4-, -DRWY6-, AND -DRWY7- AS SHOWN ON TMP-12, AND TMP-13.

STEP 5: PLACE TEMPORARY PAVEMENT MARKINGS ON -L- (WILSON AVE.) AS SHOWN ON TMP-17, 18 AND OPEN -L- (WILSON AVE.) TO TRAFFIC.

STEP 6: PLACE TEMPORARY PAVEMENT MARKINGS ON -L- AND -Y- AS SHOWN ON TMP 14 TO TMP-23 AND SHIFT TRAFFIC ON TO THE PHASE II PATTERN.

PHASE II (TMP-14 TO TMP-23)

PHASE II (TMP-14 TO TMP-23)

USING TEMPORARY LANE CLOSURES AND FLAGGING OPERATIONS PER RSD 1101.02 AS NEEDED, PERFORM THE FOLLOWING:

STEP 1: WEDGE THE -L- / -Y- INTERSECTION FROM -Y- STA. 36+15+/- TO -Y- STA. 37+70+/- AS SHOWN ON TMP-17.

STEP 2: BEGIN CONSTRUCTION OF THE FOLLOWING:

- RIGHT SIDE OF -L- FROM STA. 15+25+/- TO STA. 62+03+/- INCLUDING REMAINDER OF THE CULVERT STARTED IN PHASE I, MEDIANS AND ISLANDS FROM -L- STA. 33+15+/- TO STA. 47+52+/-, -Y1-, -Y4-, -Y5-, AND -DRWY2-. (SEE TMP-14, 15, 16, 17)
- NOTE: USING WEDGING AND INCIDENTAL STONE AS NEEDED, MAINTAIN ACCESS TO -DRWY1- AND -DRWY2- AT ALL TIMES AS DIRECTED BY THE ENGINEER. (SEE TMP-14 & 15)
- RIGHT SIDE OF -Y- FROM STA. 13+75+/- TO STA. 35+32 +/-, STA. 37+70+/- TO STA. 40+50+/-, AND STA. 41+50+/- TO STA. 56+40+/- UP TO BUT NOT INCLUDING THE FINAL LAYER OF SURFACE COURSE. (SEE TMP-17, 19, 20, 21)
 - COMPLETE -DRWY7- INCLUDING SIDEWALK AND CURB. REMOVE -DRWY8- FROM STA. 10+24+/- TO STA. 11+33+/-.

NOTE: PHASE II, STEPS 3 AND 4 CAN BE PERFORMED IN EITHER ORDER. HOWEVER, THE CONTRACTOR SHALL NOT WORK ON -Y5- AND -Y7- AT THE SAME TIME.

STEP 3: CLOSE -Y7- AS SHOWN ON TMP-17. CONSTRUCT -Y7- FROM STA. 15+35+/- TO STA. 16+42+/- (EXCEPT FOR KEYED IN ISLAND) AND THE RIGHT SIDE OF -Y- FROM STA. 40+50+/- TO STA. 41+50+/- UP TO BUT NOT INCLUDING THE FINAL LAYER OF SURFACE COURSE. (SEE TMP-17)

STEP 4: CONSTRUCT -Y5- FROM STA. 11+57+/- TO STA. 18+03+/- UP TO BUT NOT INCLUDING THE FINAL LAYER OF SURFACE COURSE AS SHOWN ON TMP-22.

CONSTRUCT REMAINING DRIVEWAYS ON THE RIGHT SIDE OF -Y- AS SHOWN ON TMP-21.

STEP 5: CONSTRUCT PROPOSED KEYED-IN ISLANDS ON -L- FROM STA. 69+10+/- TO STA. 74+55+/- AS SHOWN ON TMP-18.

STEP 6: COMPLETE ALL CONSTRUCTION STARTED IN PHASE II, STEP 2.

STEP 7: PLACE TEMPORARY PAVEMENT MARKINGS AND TRAFFIC CONTROL DEVICES ON AS SHOWN SHEETS TMP24 TO TMP 30 AND SHIFT TRAFFIC TO THE PHASE III PATTERN.

PHASE III (TMP-24 TO TMP-33)

STEP 1:

USING LANE CLOSURES AND FLAGGING OPERATIONS PER ROADWAY STANDARD DRAWING 1101.02, SHEETS 1 & 3 OF 14, PERFORM THE FOLLOWING:

- a. CONSTRUCT THE REMAINING LEFT SIDE OF -L- FROM STA. 56+03± TO STA. 61+44± WEDGING AS NECESSARY TO MAINTAIN TRAFFIC (TMP-26), -Y2- (TMP-23), AND -Y6- (TMP-25).
- b. PLACE TRAFFIC CONTROL DEVICES ON -L- FROM STA. 18+37± TO STA. 61+53± AND -Y- FROM STA. 13+75± TO STA. 34+49± AS SHOWN ON TMP-23 TO TMP-29.
- c. REMOVE TEMPORARY PAVEMENT ON -L- FROM STA. 34+09± TO STA. 38+00± AS SHOWN ON TMP-24.
- d. CONSTRUCT AWAY FROM TRAFFIC THE FOLLOWING UP TO BUT NOT INCLUDING THE FINAL LAYER OF SURFACE COURSE:
 - REMAINING MEDIANS AND ISLANDS ON -L- FROM STA. 19+10± TO STA. 61+53± EXCLUDING THE ISLAND AT -L- STA. 60+97± AS SHOWN ON TMP-24 TO TMP-27.
 - REMAINING MEDIANS AND ISLAND ON -Y- FROM STA. 18+77± TO STA. 49+77± EXCLUDING THE ISLAND AT -Y- STA. 36+96± AND STA. 37+61±. (TMP-26 TO TMP-29)
 - ISLANDS ON -Y1- (TMP-23), -Y4- (TMP-25), -Y5- (TMP-29), AND -Y7- (TMP-26).
 - REMAINING SIDEWALK ON -L- FROM STA. 33+55± TO -L- STA. 34+09± AS SHOWN ON TMP-24.
 - REMAINING PROPOSED -L- FROM STA. 41+17± TO STA. 44+65± AS SHOWN ON TMP-25.

STEP 2:

- USING TEMPORARY LANE CLOSURES PER ROADWAY STANDARD DRAWING 1101.02, SHEET 3 OF 14, COMPLETE THE FOLLOWING:
- PLACE TEMPORARY PAVEMENT MARKINGS (PAINT) ON ALL OF -Y- AND -L- IN THE FINAL PATTERN AS SHOWN ON TMP-30 AND IN THE FINAL PAVEMENT MARKING PLANS.
 - SHIFT TRAFFIC TO THE FINAL PATTERN ON ALL -Y- LINES AND -L-.
 - PLACE TRAFFIC CONTROL DEVICES ON -L- AND -Y- AS SHOWN ON TMP-30, AND CONSTRUCT ISLANDS AT -L- STA. 60+97±, -Y- STA. 36+96± AND STA. 37+61.

STEP 3: (NOT SHOWN)

USING TEMPORARY LANE CLOSURES PER ROADWAY STANDARD DRAWING 1101.02, SHEET 3 OF 14 PERFORM THE FOLLOWING:

PLACE THE FINAL LAYER OF SURFACE COURSE ON -L-, -Y-, -Y1-, -Y2-, -Y3-, -Y4-, -Y5-, -Y6-, -Y7-, -DRWY1-, -DRWY2-, -DRWY3-, -DRWY4-, AND -DRWY5-. PLACE FINAL PAVEMENT MARKINGS AS SHOWN IN THE PAVEMENT MARKING PLAN.

STEP 4:

REMOVE ALL TEMPORARY TRAFFIC CONTROL DEVICES AND PLACE TRAFFIC IN THE FINAL PATTERN.

8/24/2023 10:41:11 AM C:\Traffic\Transportation Management\Plan\TCP\PLAN SHEETS\IR-3833C-TMP-03-PHASING.dgn angood



Stantec Consulting Services Inc.
801 Jones Franklin Road
Suite 300
Raleigh, NC 27606
Tel. 919.851.6866
Fax. 919.851.7024
www.stantec.com
License No. F-0672

8/24/2023

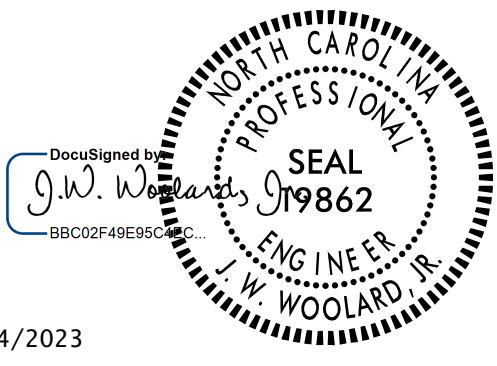

DOCUMENT NOT CONSIDERED FINAL
UNLESS ALL SIGNATURES COMPLETED

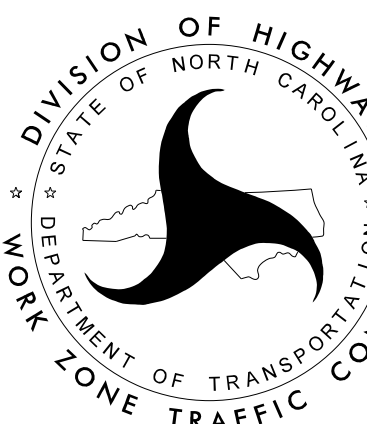

PHASING

PROJ. REFERENCE NO.	SHEET NO.
R-3833C	TMP-4

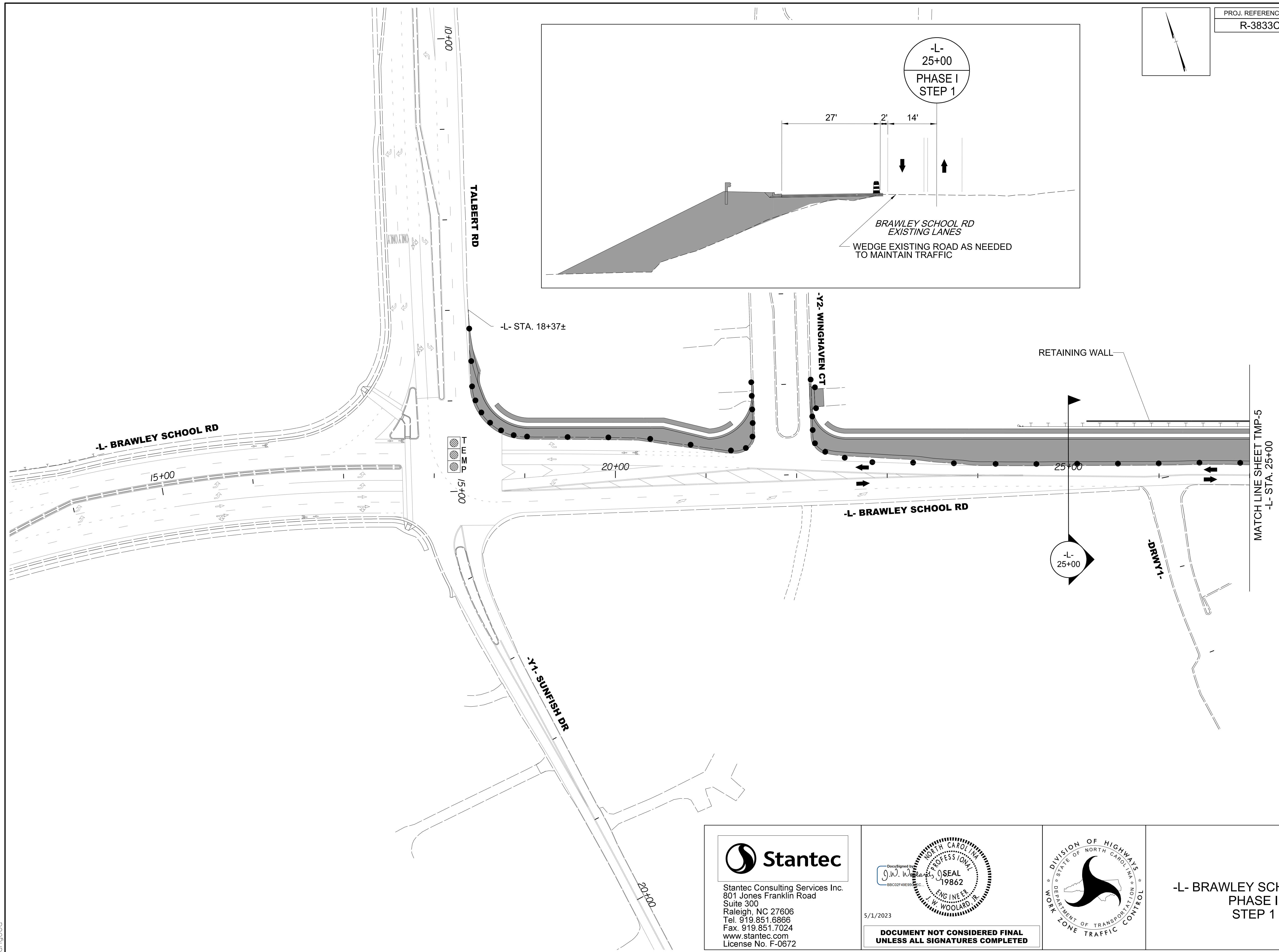
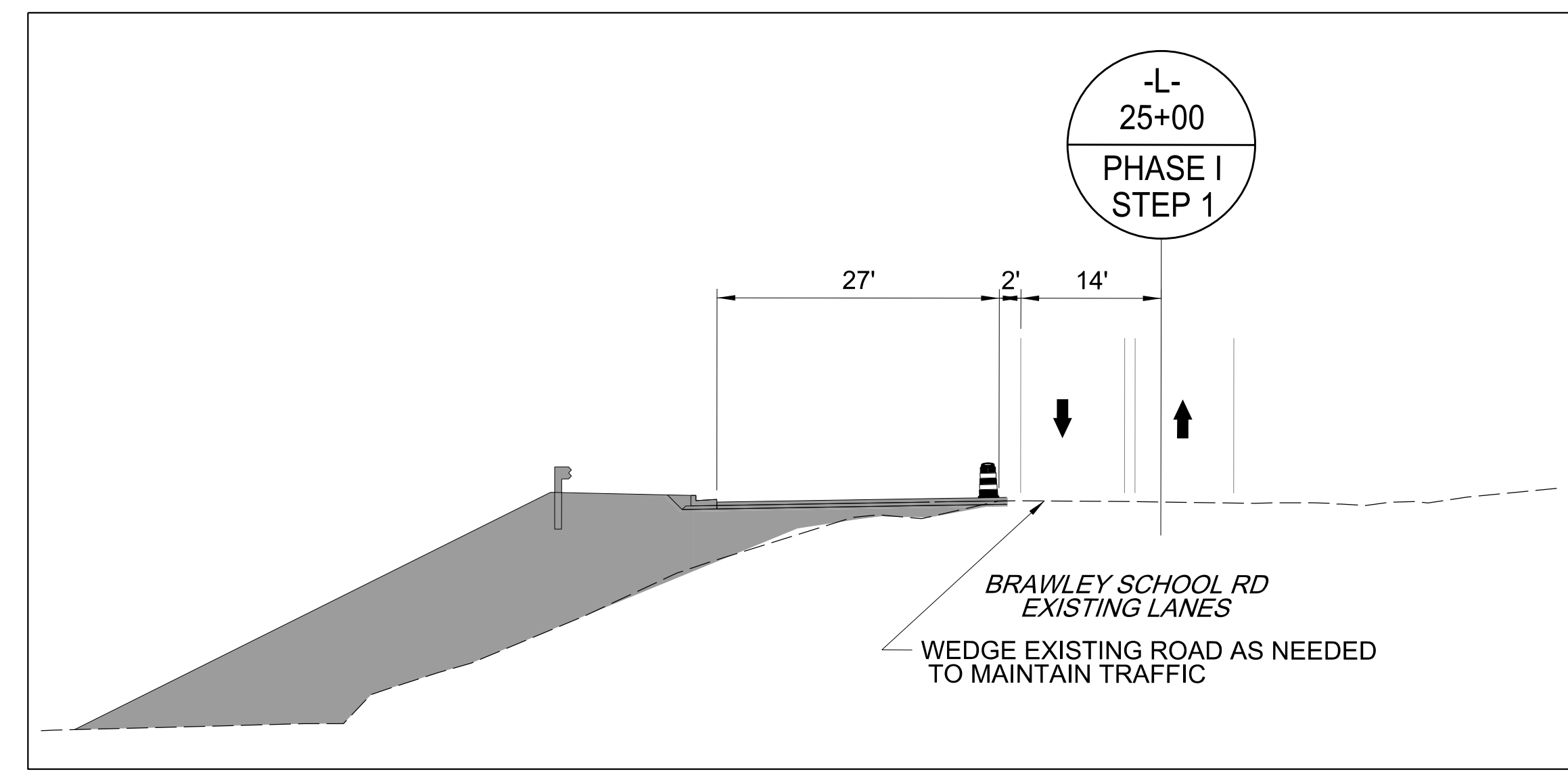
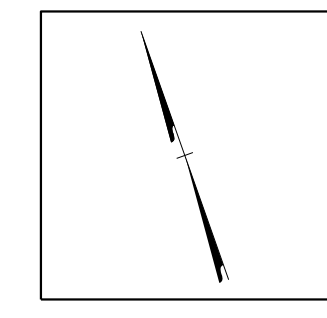

5/1/2023
 U:\Traffic\Transportation Management\Plan\TCP\PLAN SHEETS\IR-3833C-TMP_04_PHASE 1.dgn
 angood



 Stantec Consulting Services Inc.
 801 Jones Franklin Road
 Suite 300
 Raleigh, NC 27606
 Tel. 919.851.6866
 Fax. 919.851.7024
 www.stantec.com
 License No. F-0672

5/1/2023

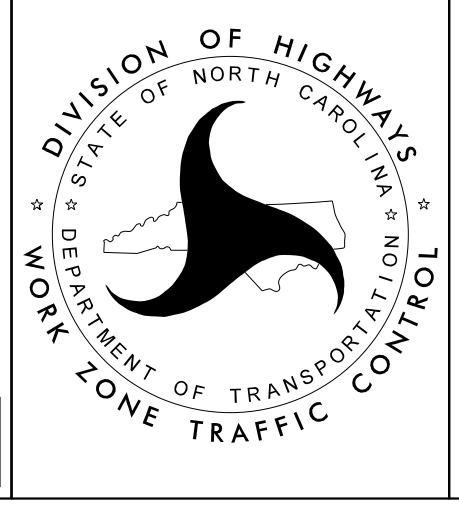
**DOCUMENT NOT CONSIDERED FINAL
 UNLESS ALL SIGNATURES COMPLETED**

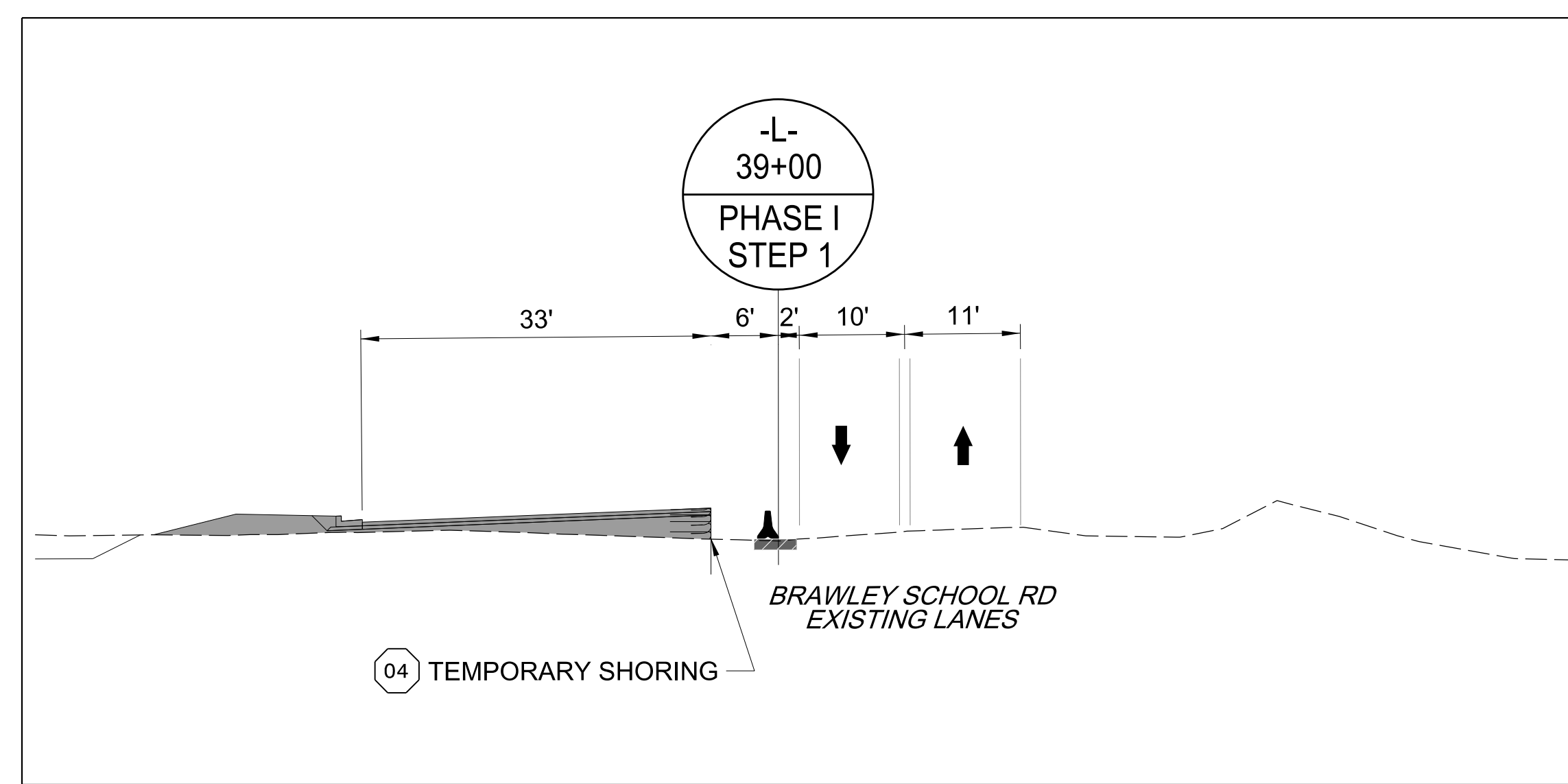
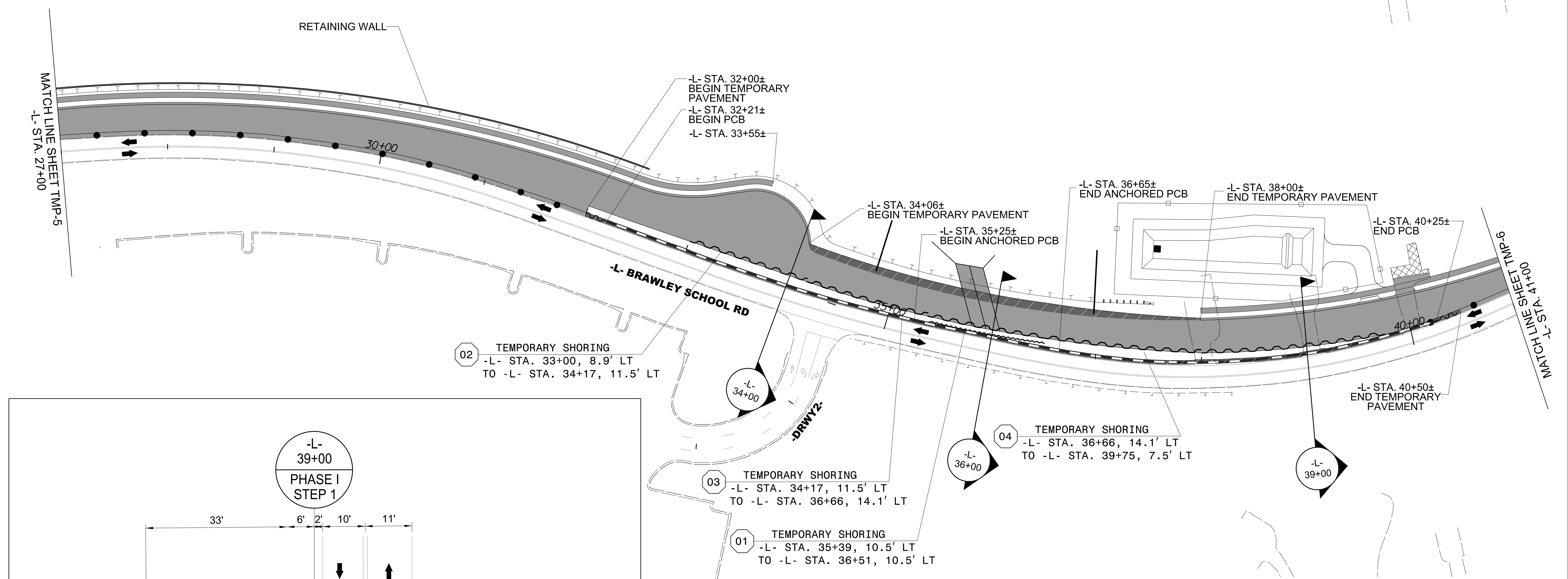
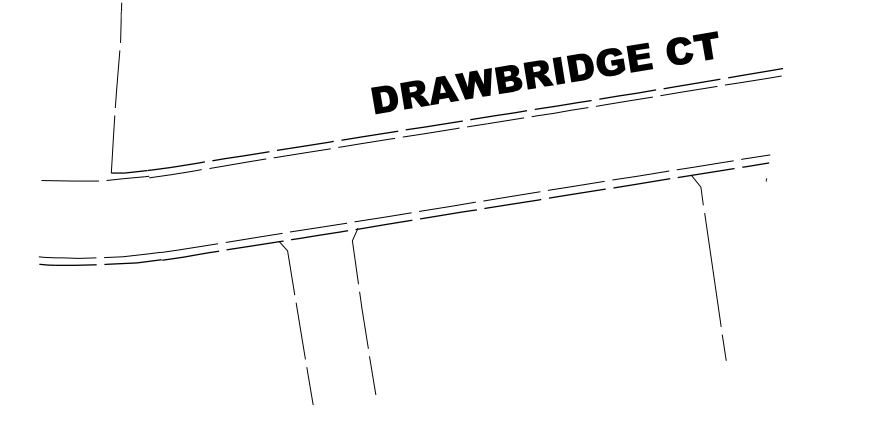
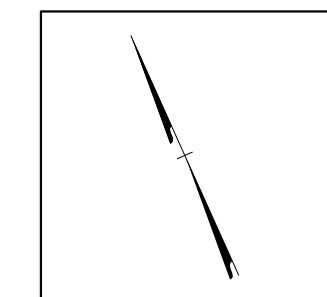
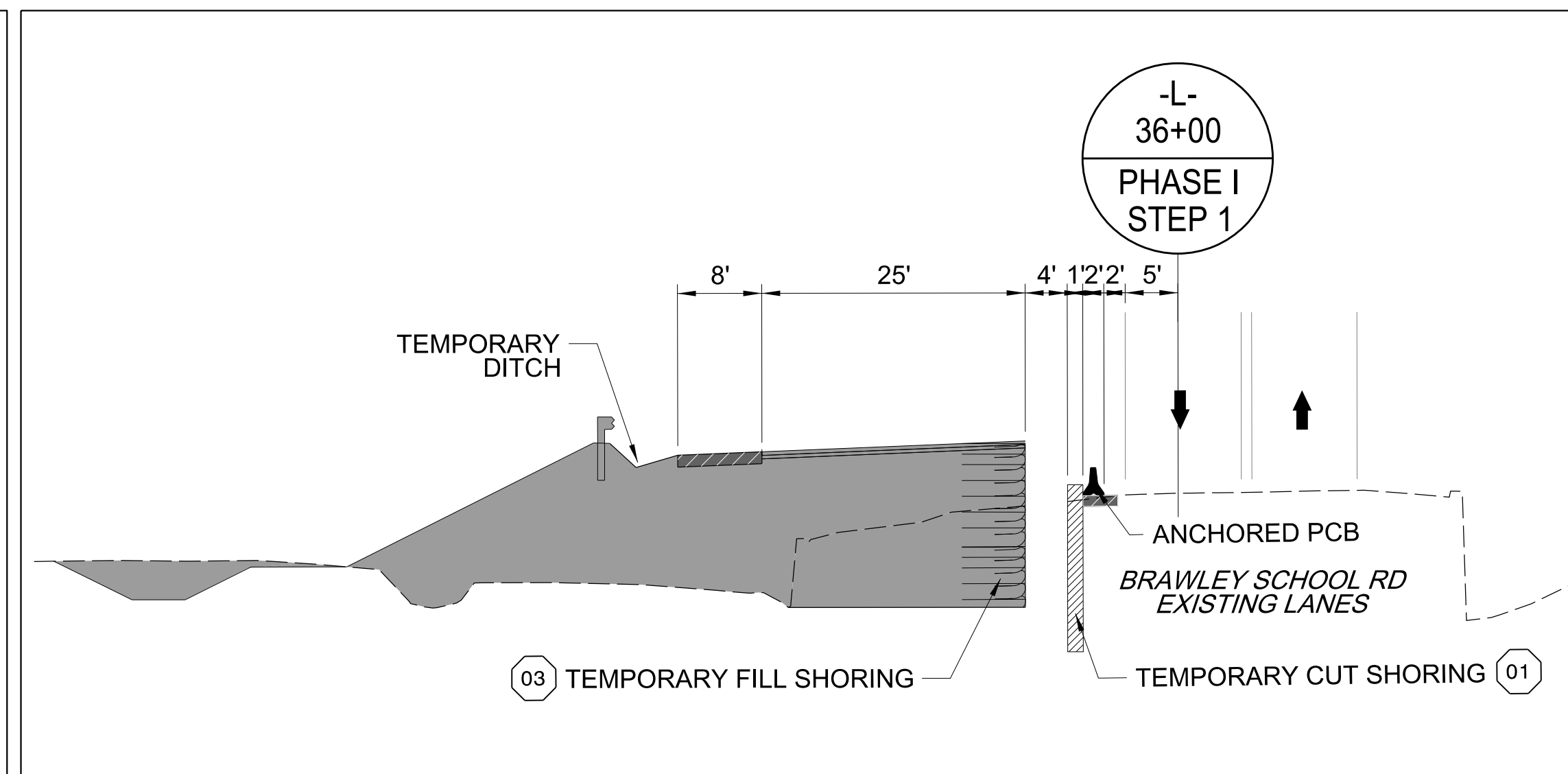
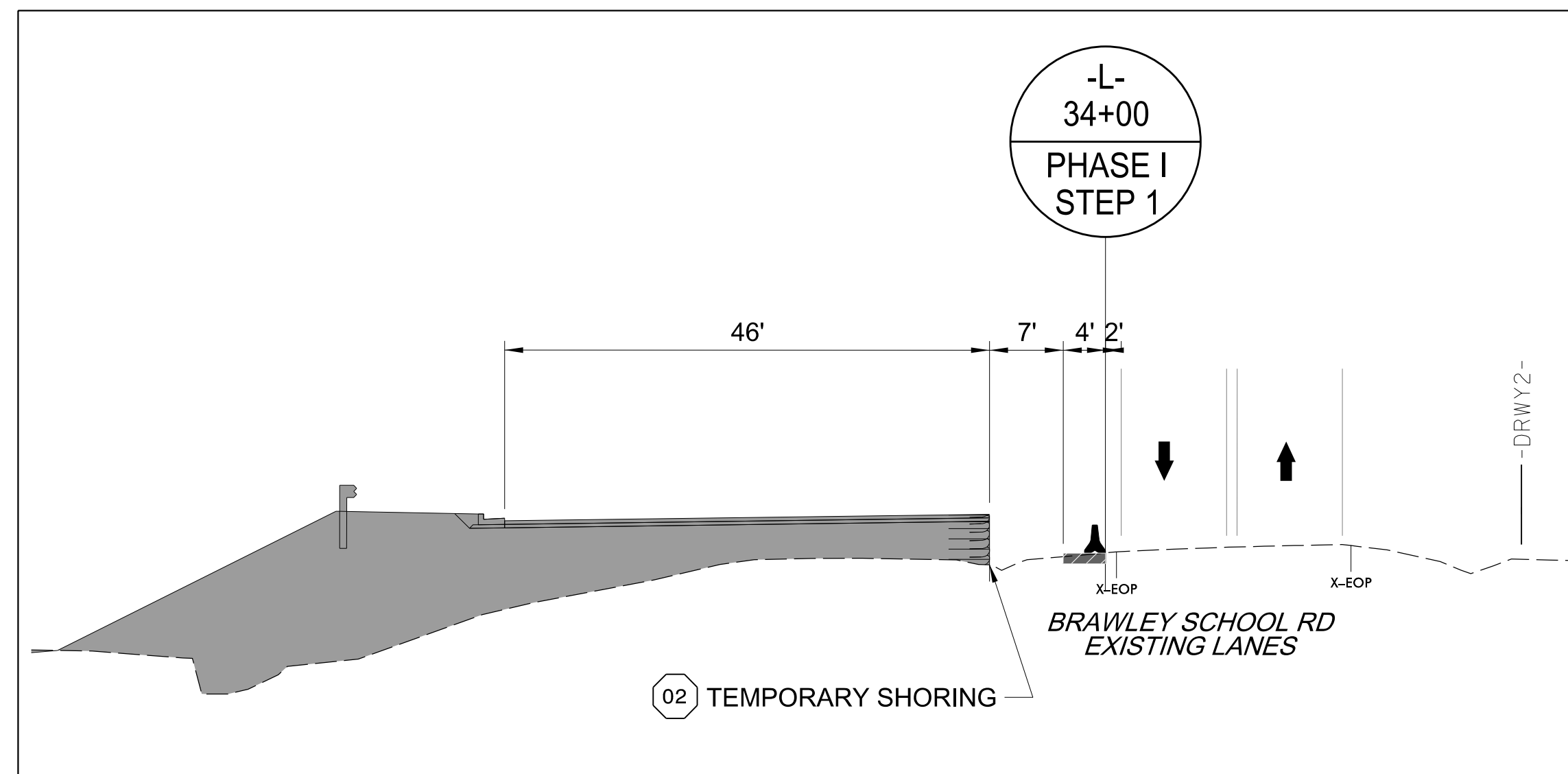

**-L- BRAWLEY SCHOOL RD
 PHASE I
 STEP 1**



Stantec

Stantec Consulting Services Inc.
801 Jones Franklin Road
Suite 300
Raleigh, NC 27606
Tel. 919.851.6866
Fax. 919.851.7024
www.stantec.com
License No. F-0672

5/1/2023

**DOCUMENT NOT CONSIDERED FINAL
UNLESS ALL SIGNATURES COMPLETED**

DIVISION OF HIGHWAYS
STATE OF NORTH CAROLINA
DEPARTMENT OF TRANSPORTATION
WORK ZONE TRAFFIC CONTROL

-L- BRAWLEY SCHOOL RD
PHASE I
STEP 1

5/1/2023
L:\Traffic\Transportation Management Plan\TCP\PLAN SHEETS\IR-3833C-TMP_05_PHASE 1.dgn
angood

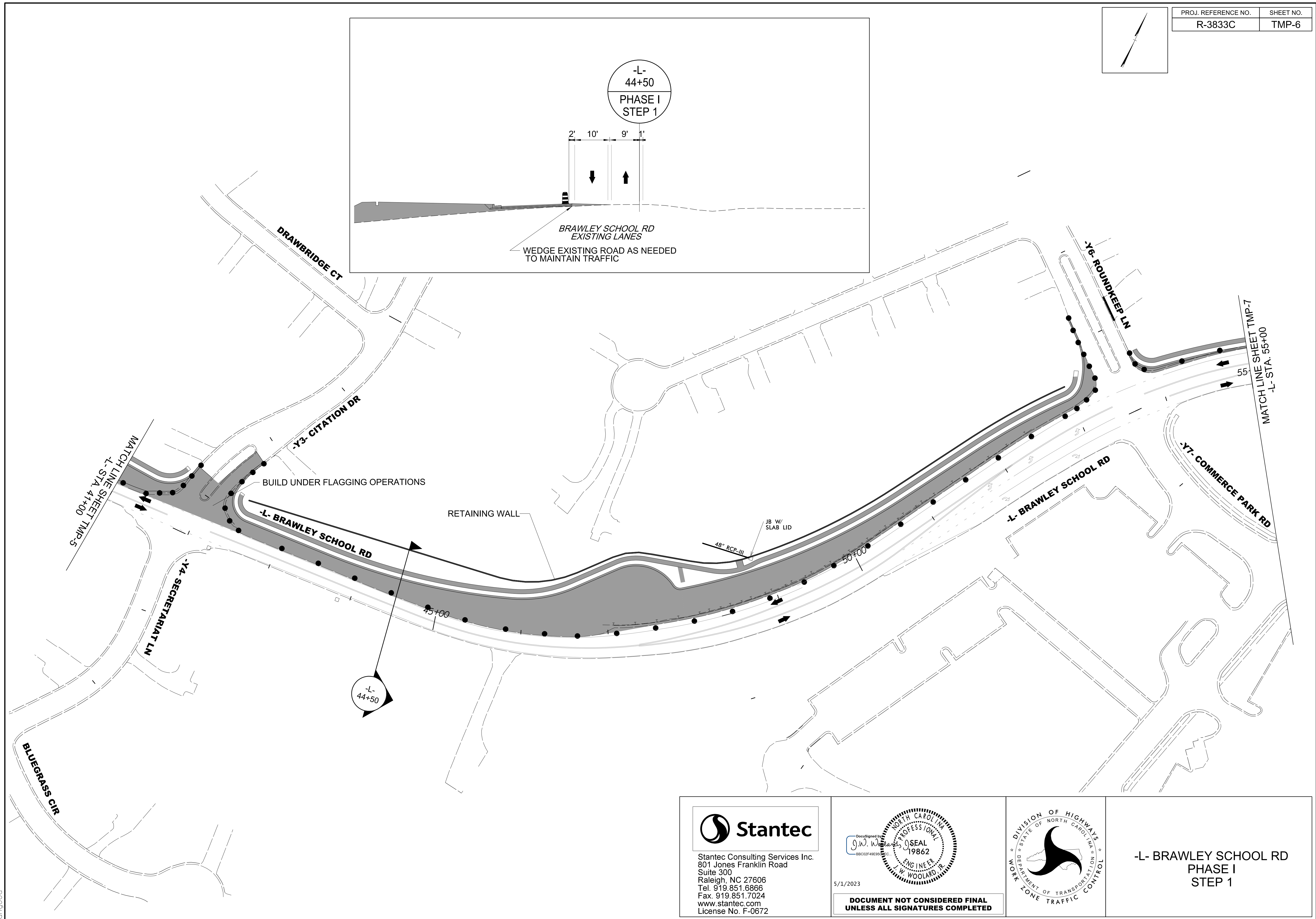
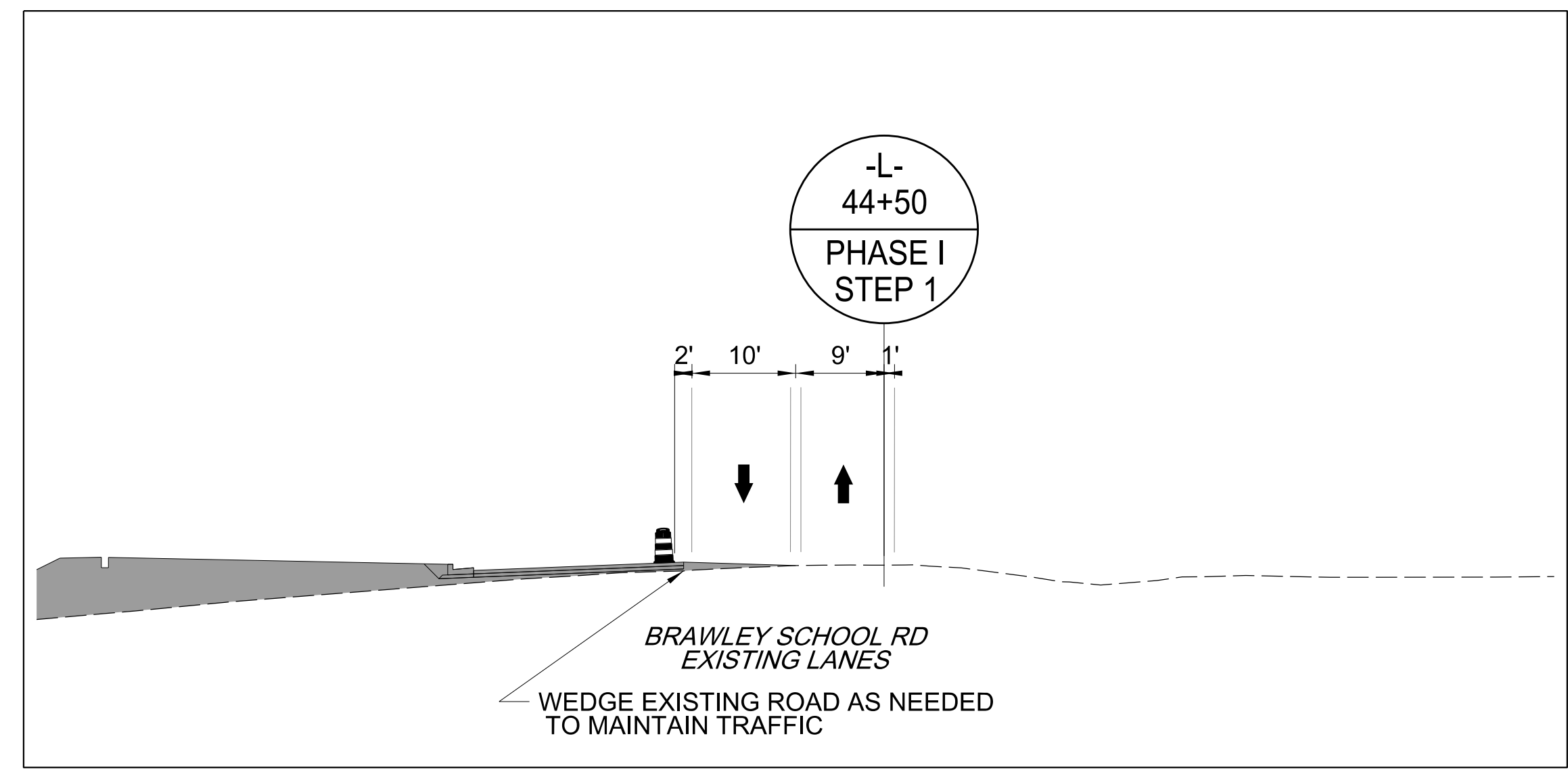
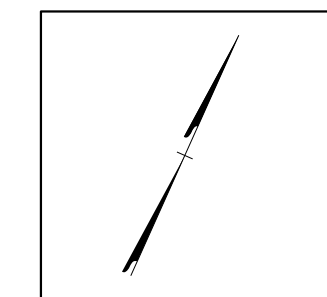

5/1/2023
L:\Traffic\Transportation Management\Plan\TCP\PLAN SHEETS\IR-3833C-TMP_06_PHASE 1.dgn
angood

Stantec
Stantec Consulting Services Inc.
801 Jones Franklin Road
Suite 300
Raleigh, NC 27606
Tel. 919.851.6866
Fax. 919.851.7024
www.stantec.com
License No. F-0672

5/1/2023

**DOCUMENT NOT CONSIDERED FINAL
UNLESS ALL SIGNATURES COMPLETED**

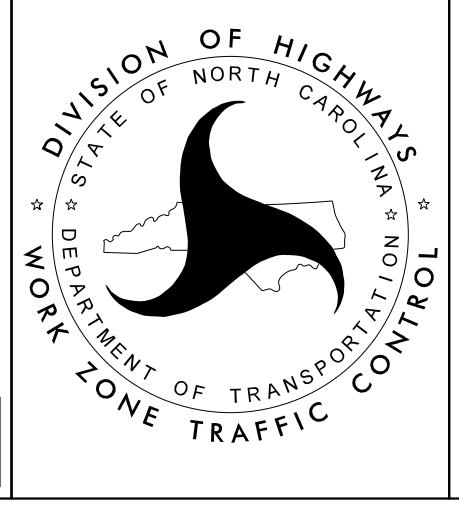

**-L- BRAWLEY SCHOOL RD
PHASE I
STEP 1**

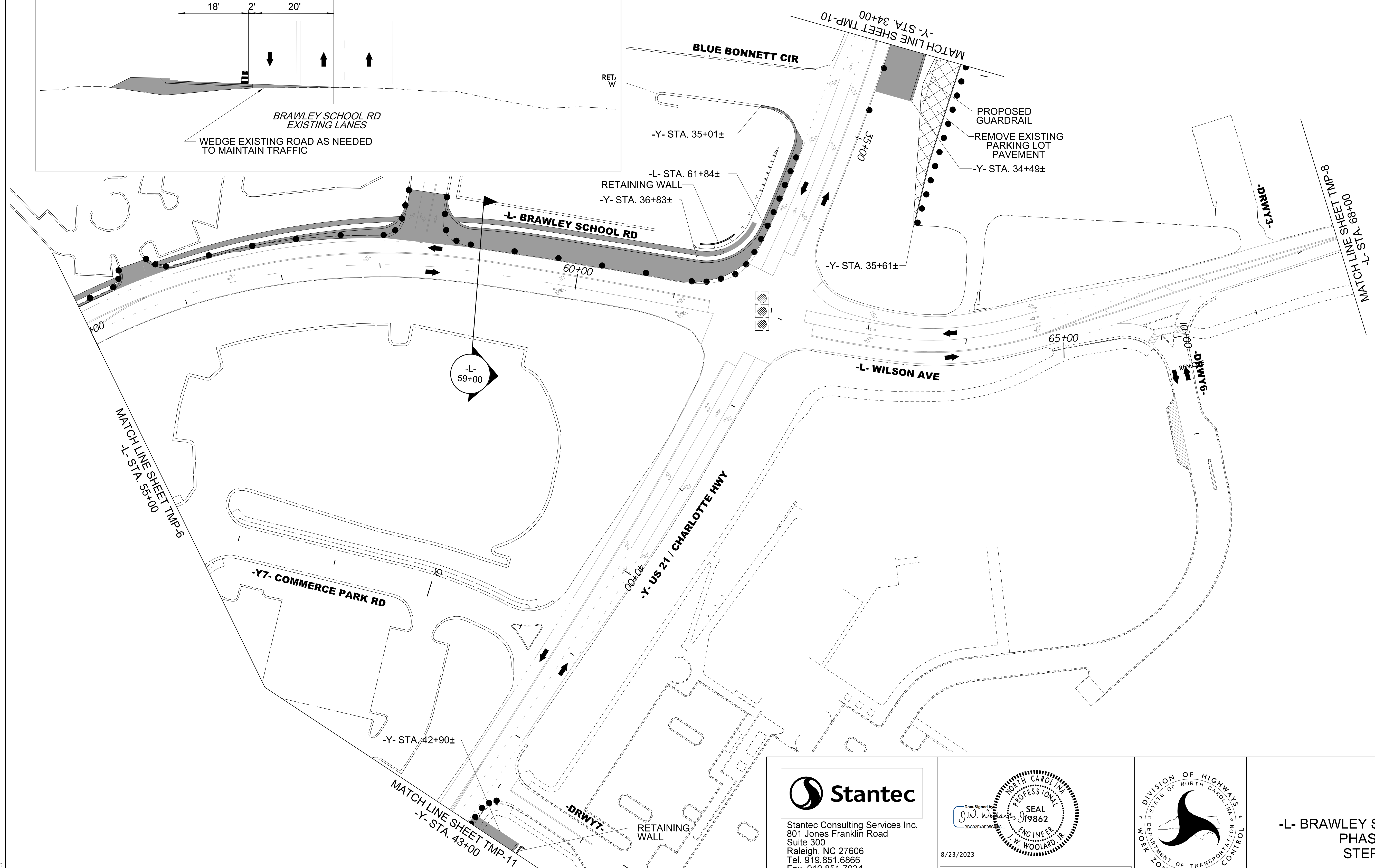
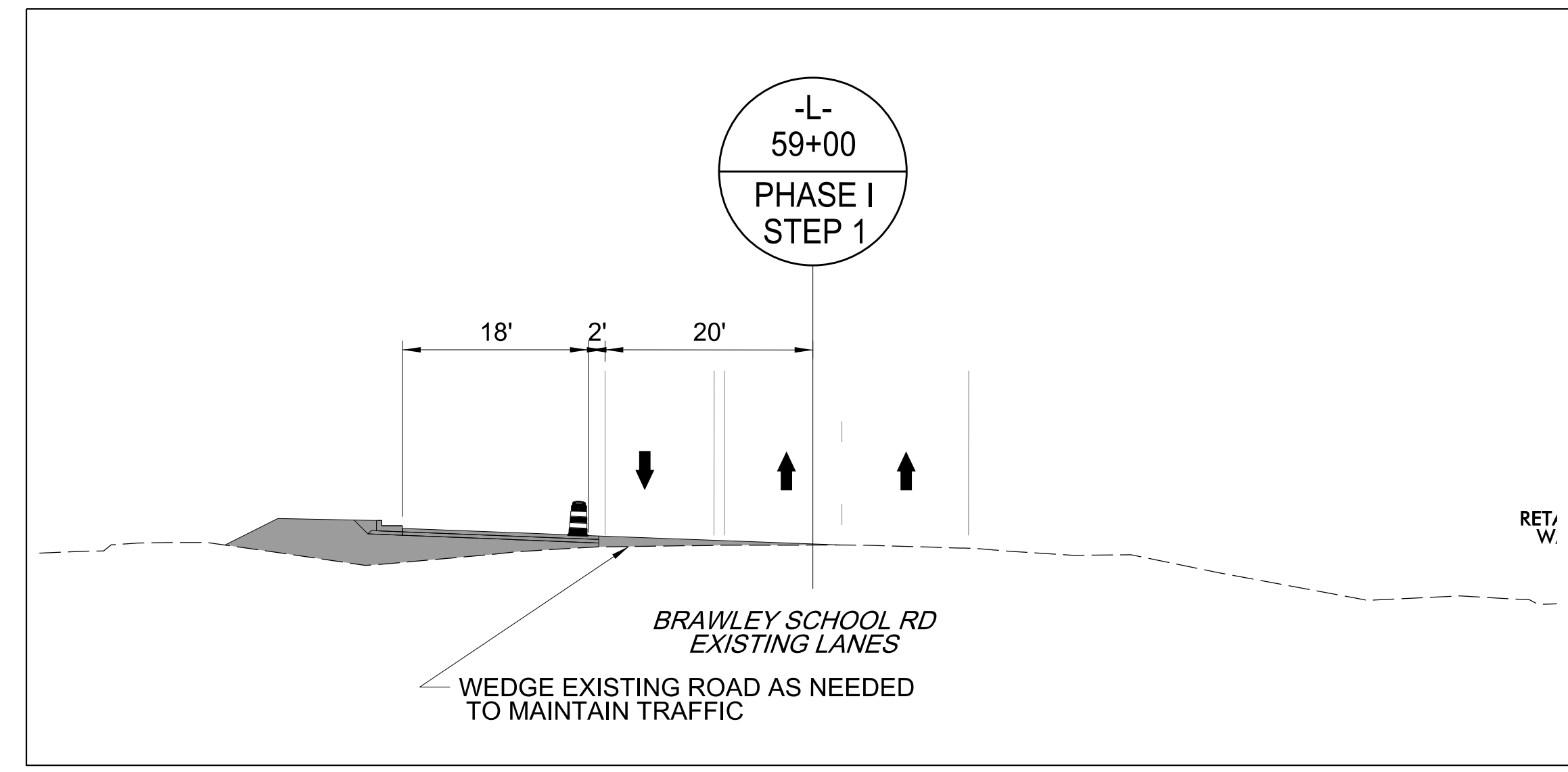
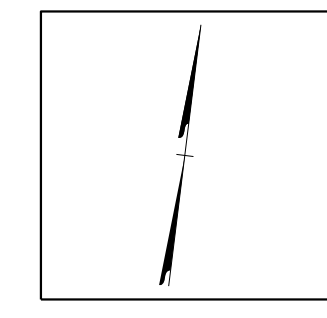

8/23/2023
 U:\Traffic\Transportation Management Plan\TCP\PLAN SHEETS\IR-3833C-TMP_07_PHASE 1.dgn
 angood

 Stantec Consulting Services Inc.
 801 Jones Franklin Road
 Suite 300
 Raleigh, NC 27606
 Tel. 919.851.6866
 Fax. 919.851.7024
 www.stantec.com
 License No. F-0672

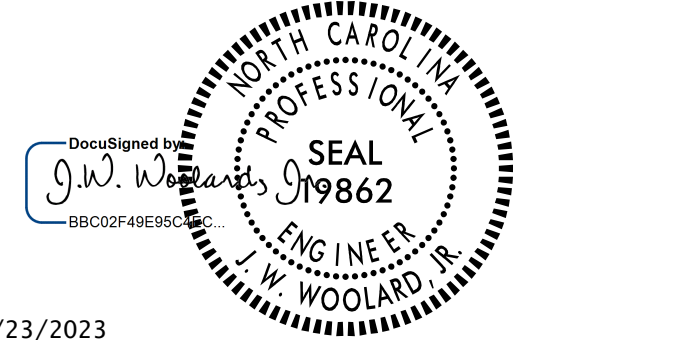
8/23/2023

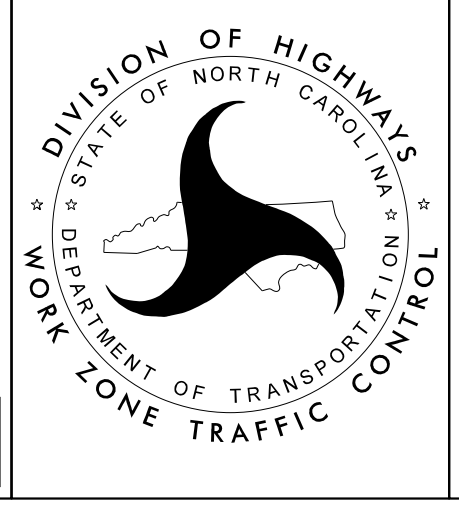
**DOCUMENT NOT CONSIDERED FINAL
 UNLESS ALL SIGNATURES COMPLETED**

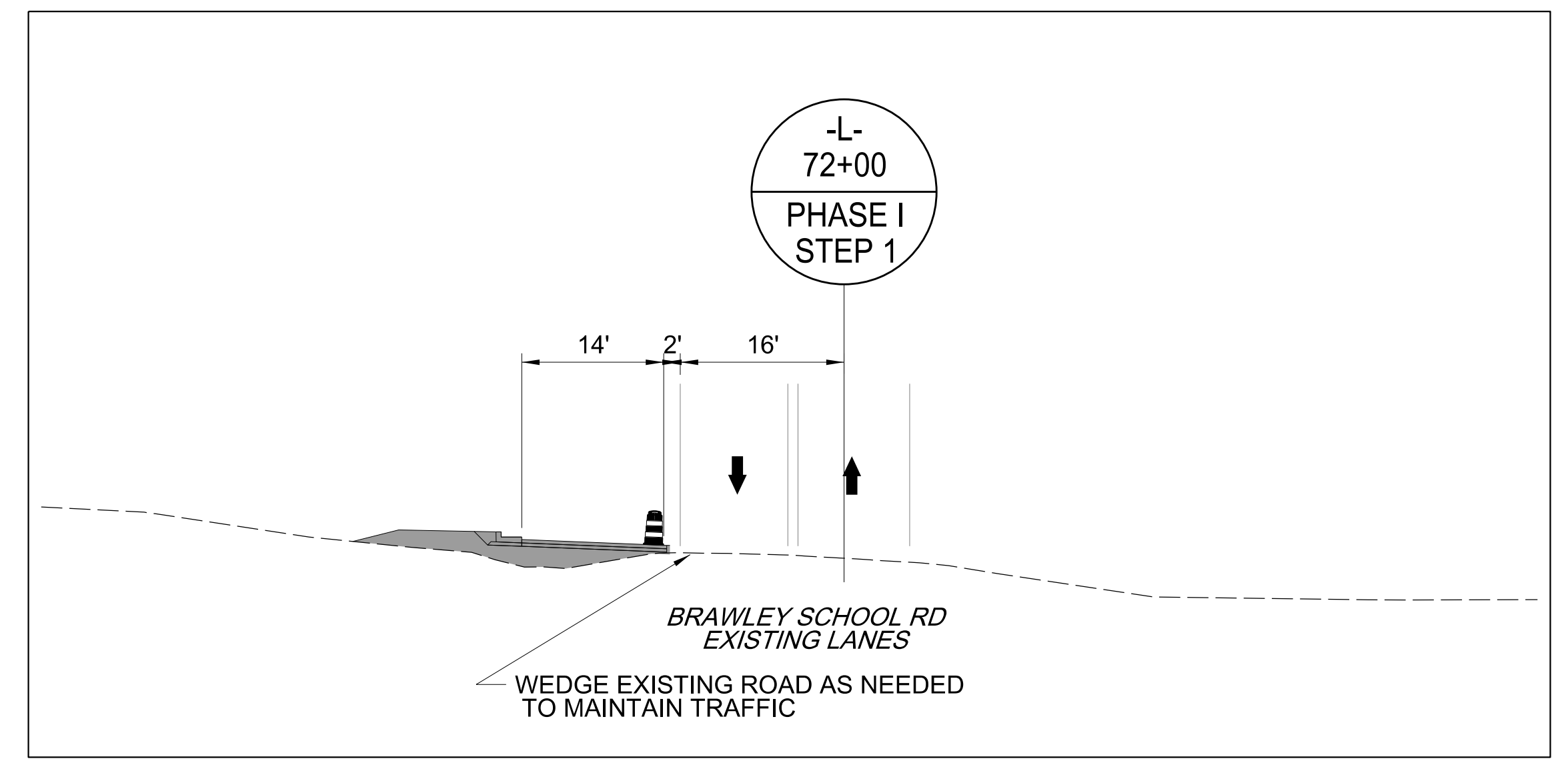
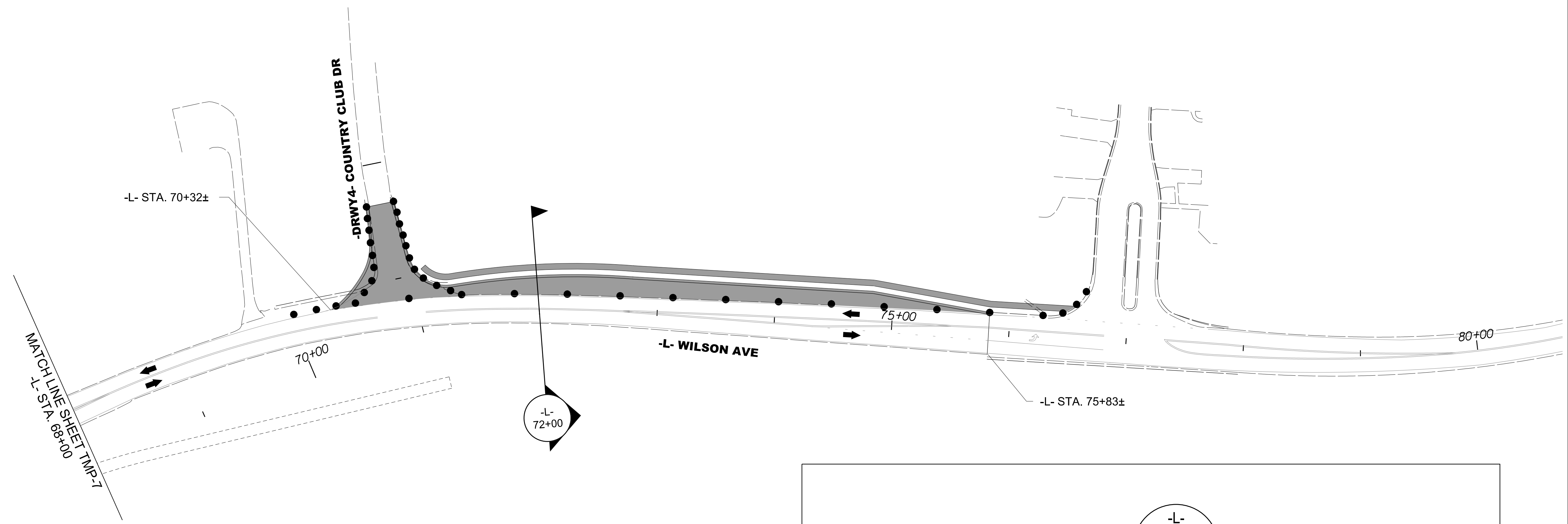
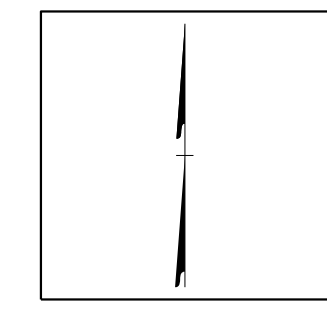

**-L- BRAWLEY SCHOOL RD
 PHASE I
 STEP 1**



5/1/2023
 U:\Traffic\Transportation Management\Plan\TCP\PLAN SHEETS\IR-3833C-TMP_08_PHASE 1.dgn
 angood

Stantec
 Stantec Consulting Services Inc.
 801 Jones Franklin Road
 Suite 300
 Raleigh, NC 27606
 Tel. 919.851.6866
 Fax. 919.851.7024
 www.stantec.com
 License No. F-0672

5/1/2023

**DOCUMENT NOT CONSIDERED FINAL
 UNLESS ALL SIGNATURES COMPLETED**

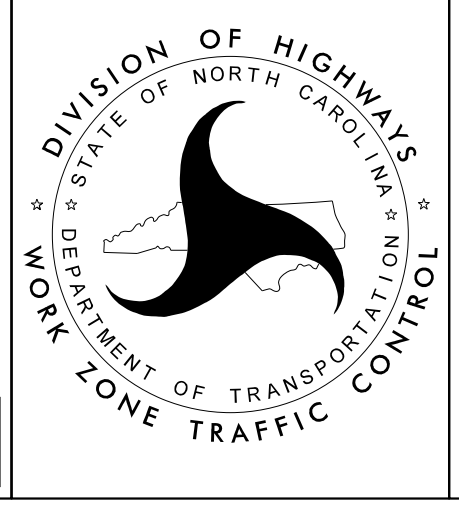

**-L- BRAWLEY SCHOOL RD
 PHASE I
 STEP 1**

PROJ. REFERENCE NO.	SHEET NO.
R-3833C	TMP-9

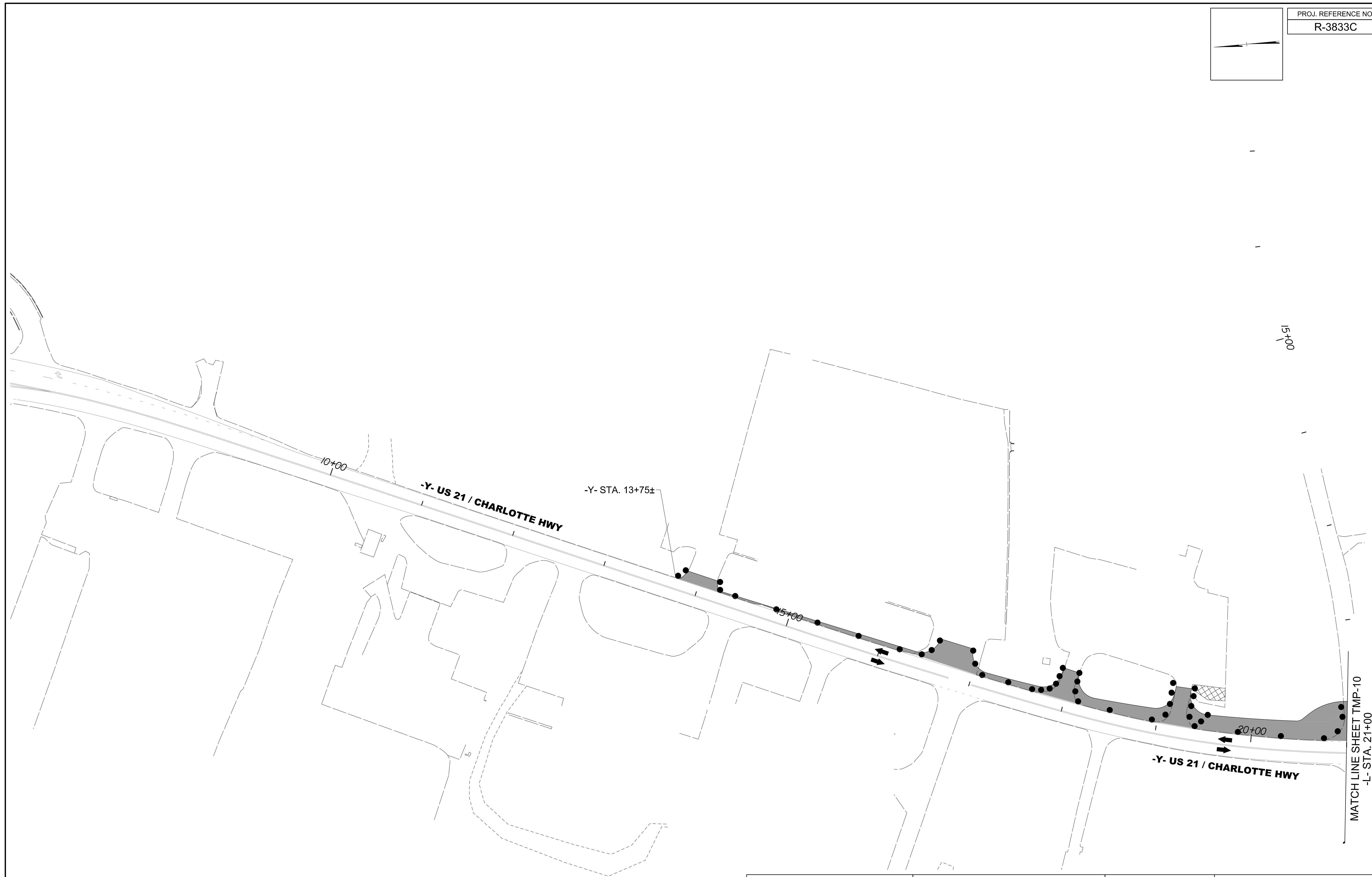
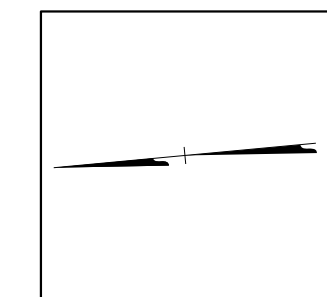

MATCH LINE SHEET TMP-10
-L- STA. 21+00

5/1/2023
L:\Traffic\Transportation Management\Plan\TCP\PLAN SHEETS\IR-3833C-TMP_09_PHASE 1.dgn
angood

Stantec
Stantec Consulting Services Inc.
801 Jones Franklin Road
Suite 300
Raleigh, NC 27606
Tel. 919.851.6866
Fax. 919.851.7024
www.stantec.com
License No. F-0672

DocuSigned by:
J.W. Woolard
19862
V. W. WOOLARD, R.
5/1/2023

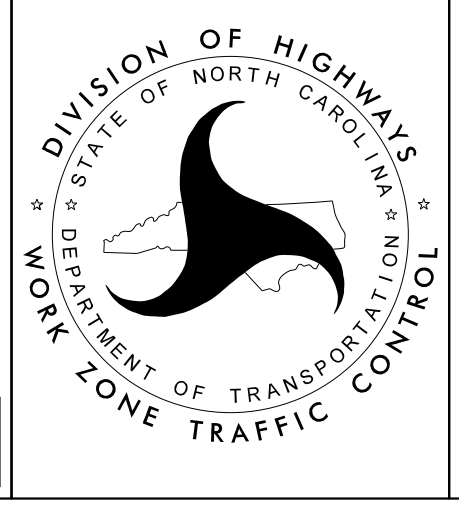

-L- BRAWLEY SCHOOL RD
PHASE I
STEP 1

**DOCUMENT NOT CONSIDERED FINAL
UNLESS ALL SIGNATURES COMPLETED**

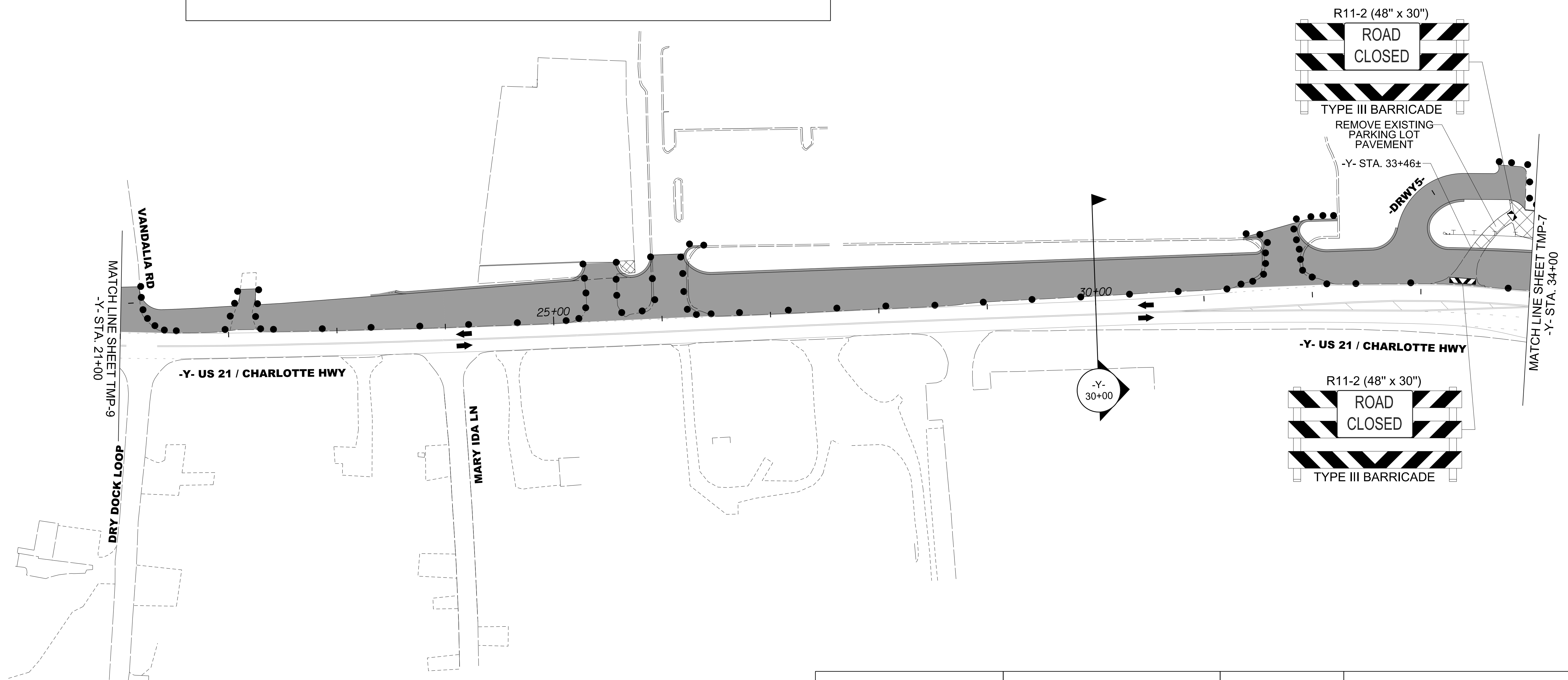
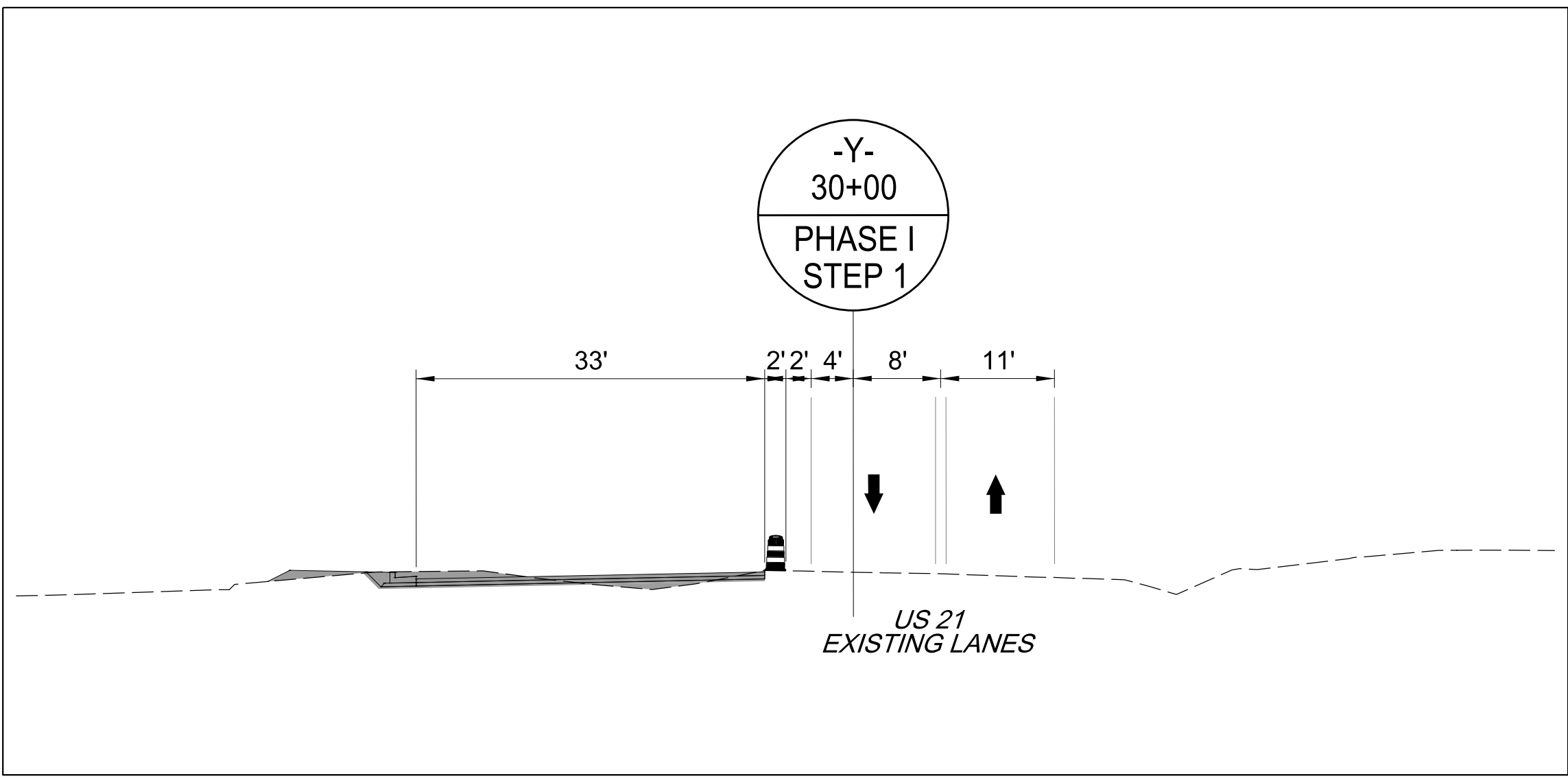
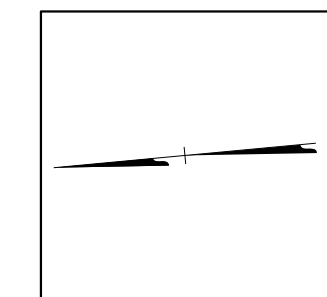

8/23/2023
 U:\Traffic\Transportation Management\Plan\TCP\PLAN SHEETS\VR-3833C-TMP-10-PHASE 1.dgn
 angood

 Stantec Consulting Services Inc.
 801 Jones Franklin Road
 Suite 300
 Raleigh, NC 27606
 Tel. 919.851.6866
 Fax. 919.851.7024
 www.stantec.com
 License No. F-0672

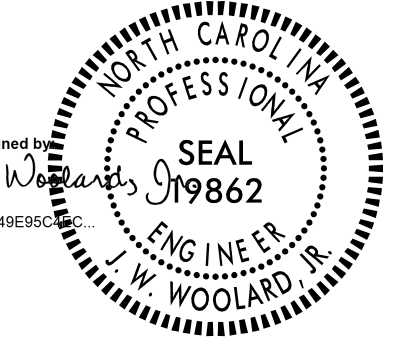
DocuSigned by:

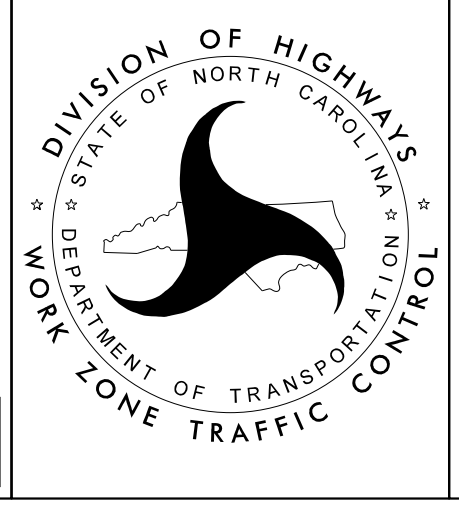
 8/23/2023
**DOCUMENT NOT CONSIDERED FINAL
 UNLESS ALL SIGNATURES COMPLETED**

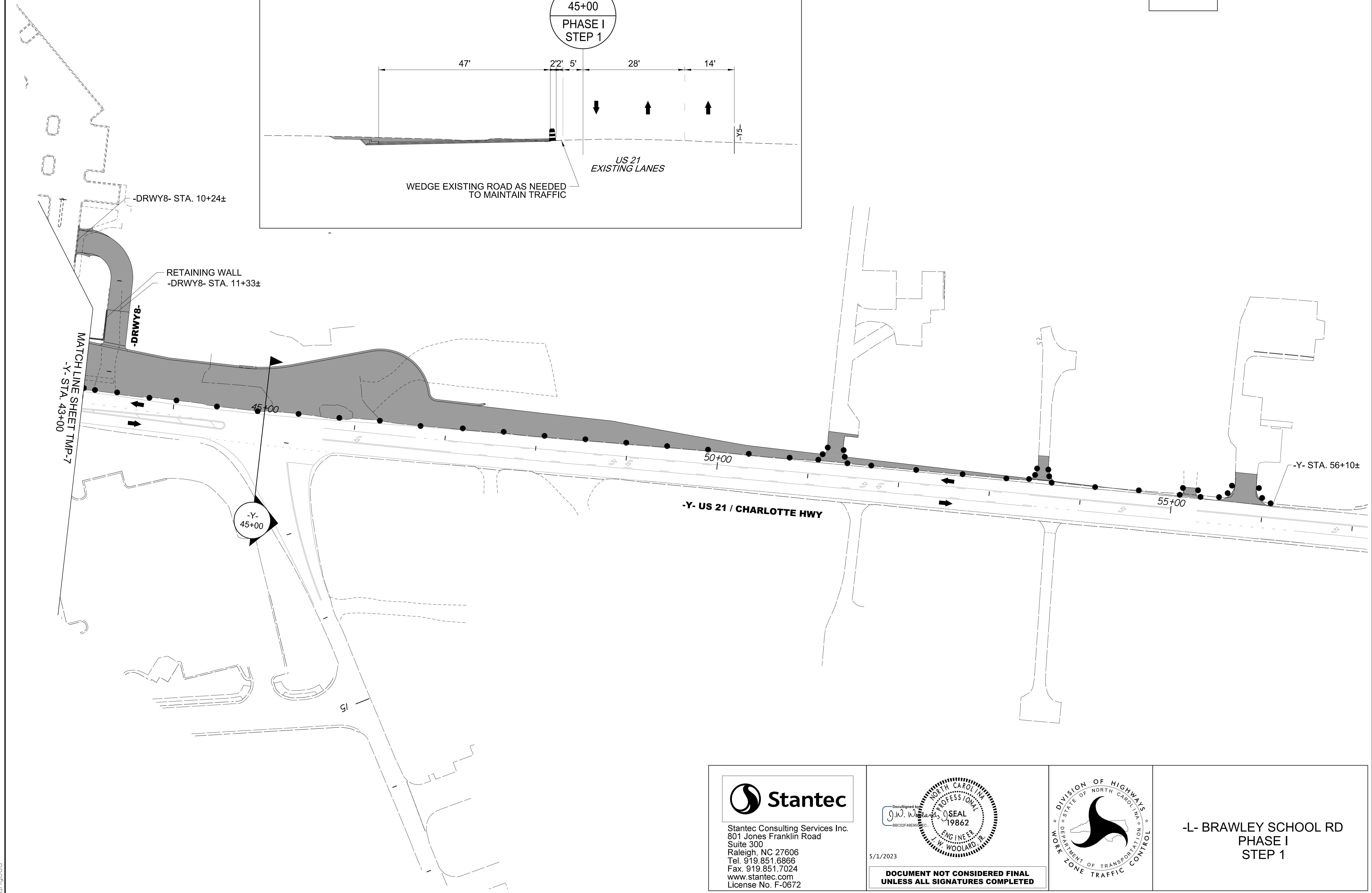
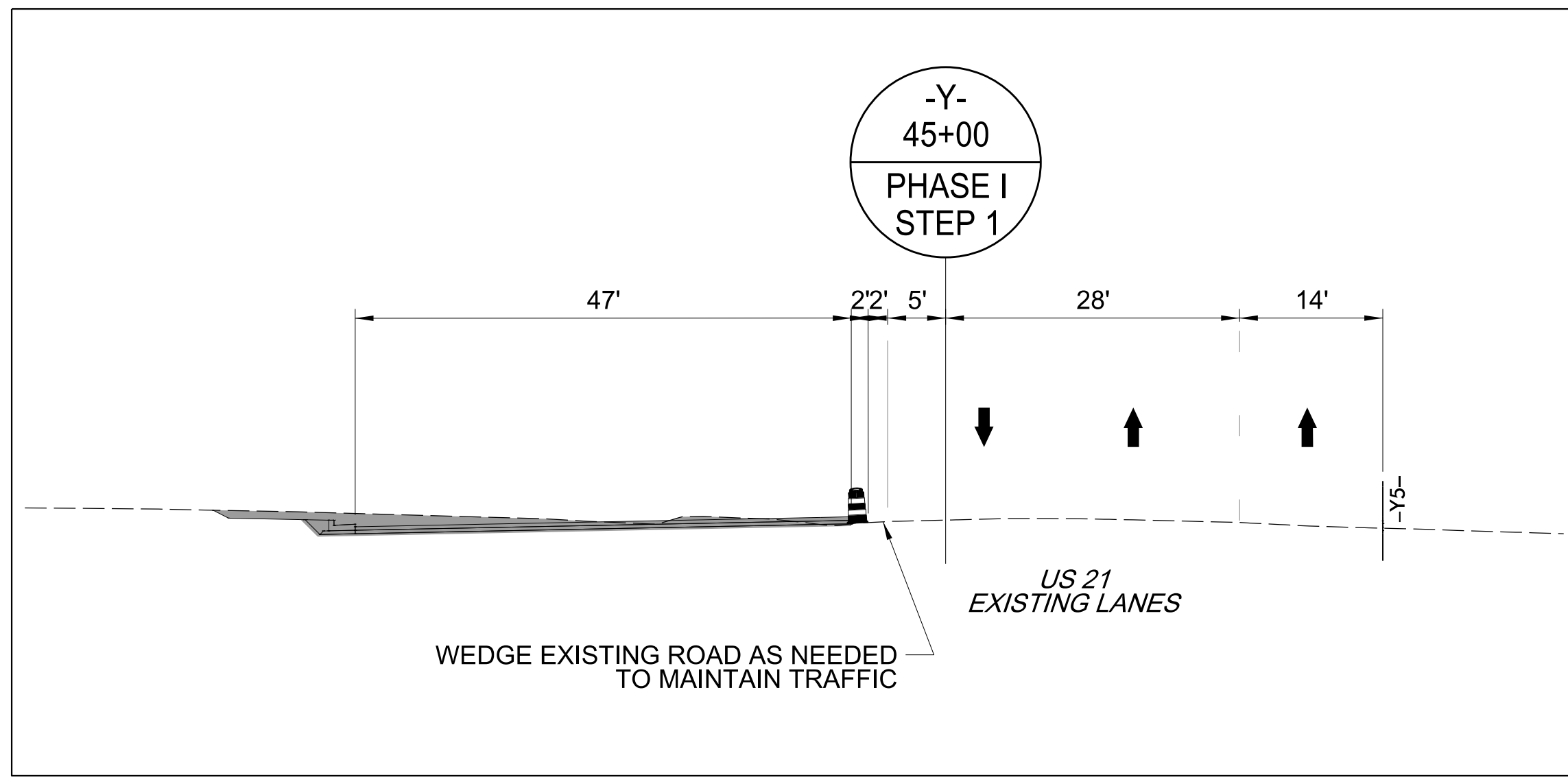
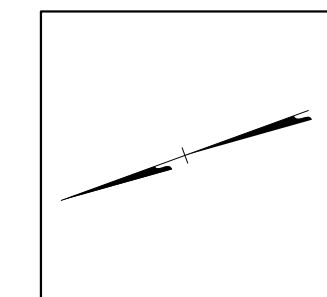

**-L- BRAWLEY SCHOOL RD
 PHASE I
 STEP 1**



5/1/2023
 Us:\Traffic\Transportation Management Plan\TCP\PLAN SHEETS\IR-3833C-TMP-11\PHASE 1.dgn
 angood

 Stantec Consulting Services Inc.
 801 Jones Franklin Road
 Suite 300
 Raleigh, NC 27606
 Tel. 919.851.6866
 Fax. 919.851.7024
 www.stantec.com
 License No. F-0672

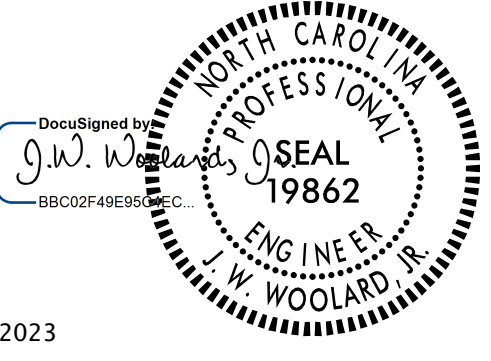
5/1/2023

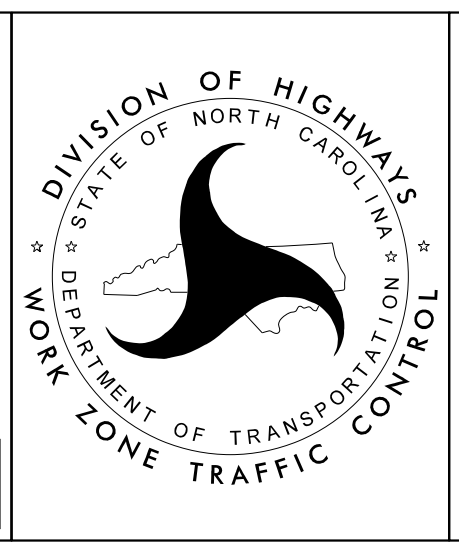
**DOCUMENT NOT CONSIDERED FINAL
 UNLESS ALL SIGNATURES COMPLETED**

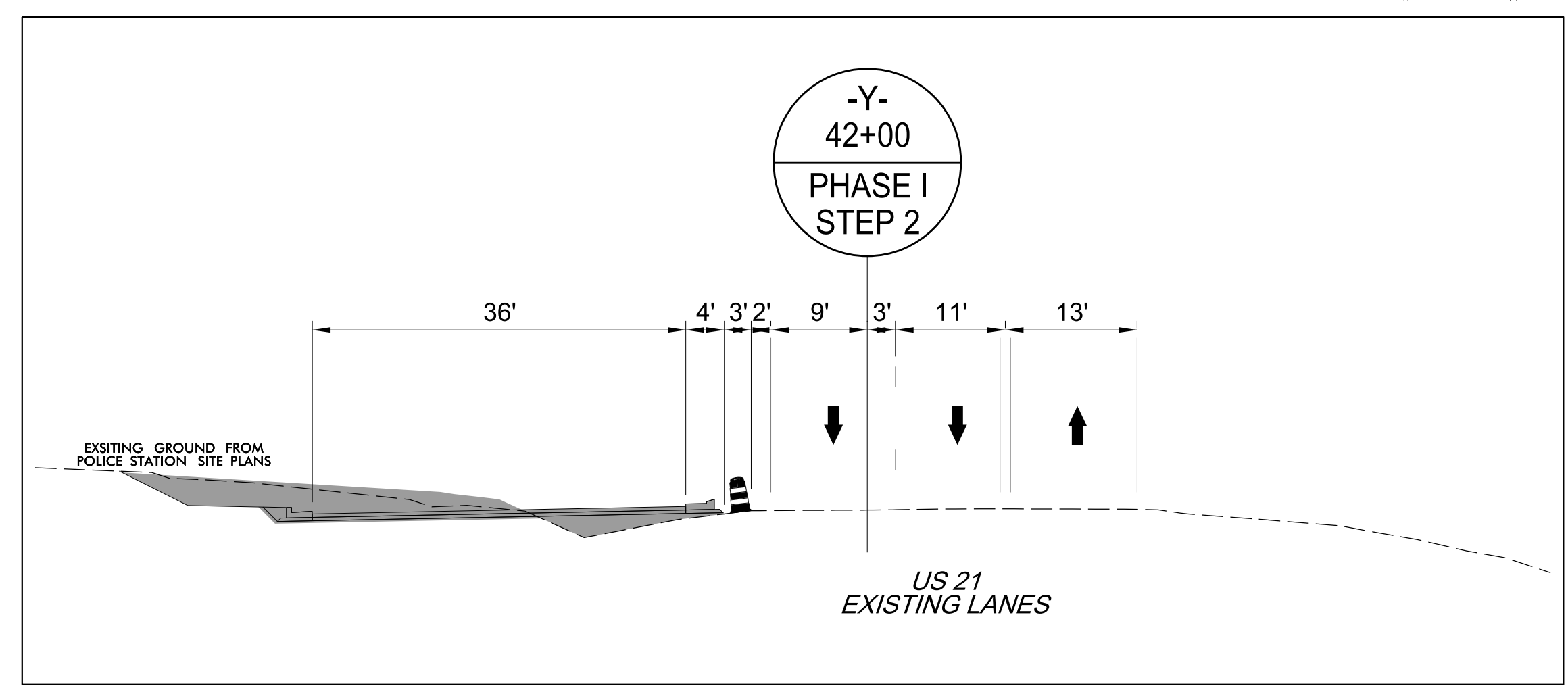
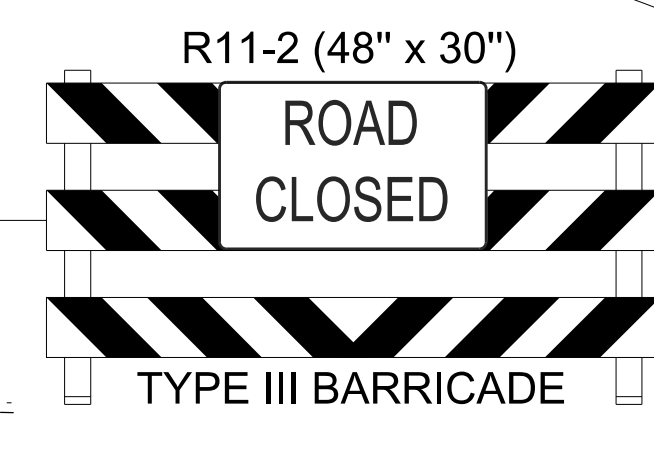
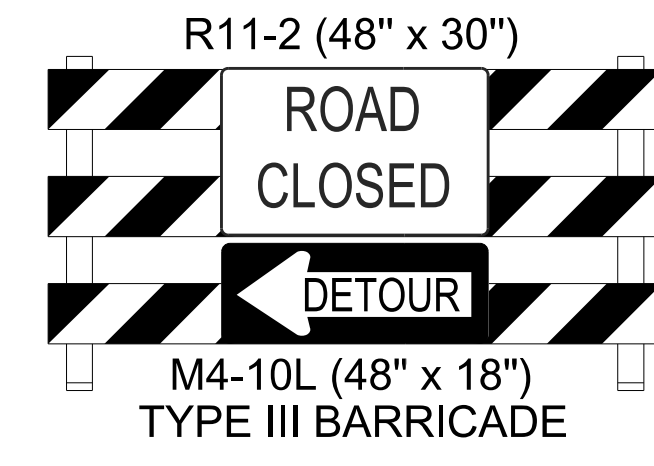
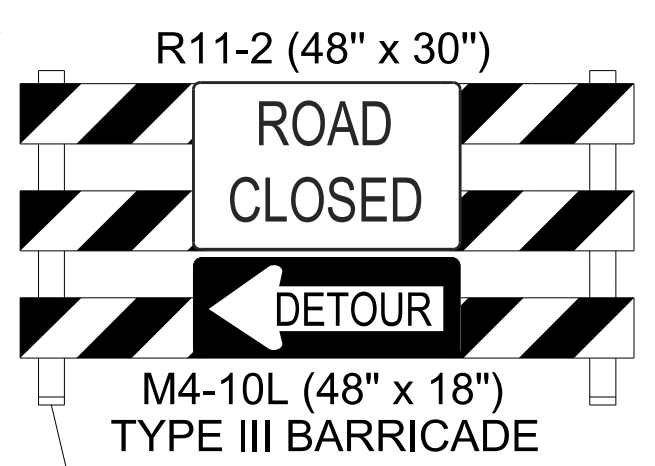
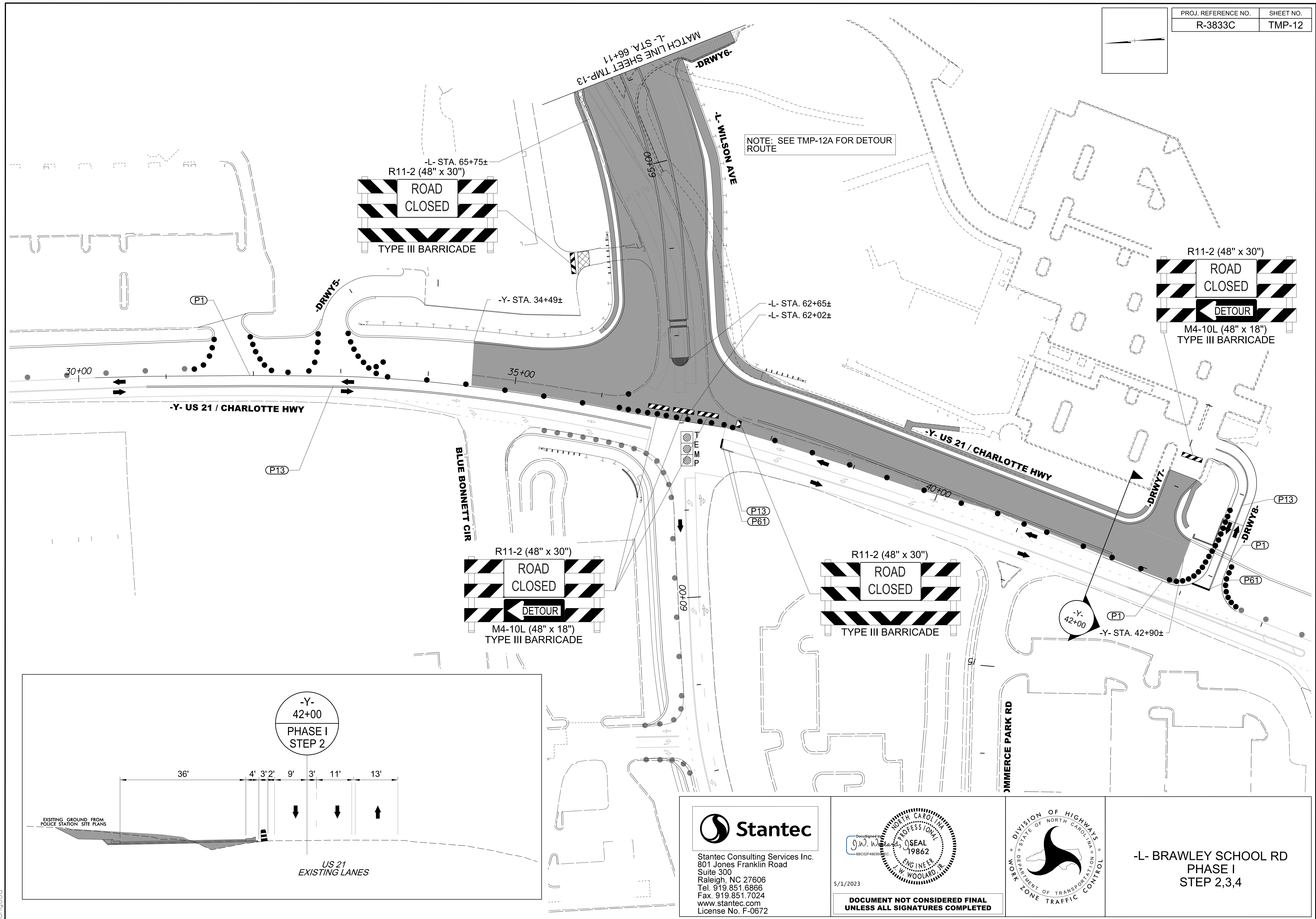
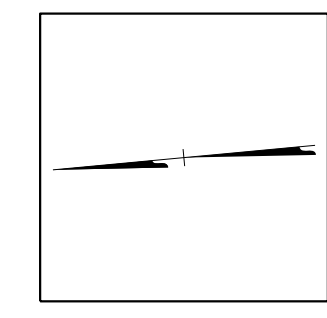

**-L- BRAWLEY SCHOOL RD
 PHASE I
 STEP 1**



Stantec
Stantec Consulting Services Inc.
801 Jones Franklin Road
Suite 300
Raleigh, NC 27606
Tel. 919.851.6866
Fax. 919.851.7024
www.stantec.com
License No. F-0672

5/1/2023
DOCUMENT NOT CONSIDERED FINAL
UNLESS ALL SIGNATURES COMPLETED

DIVISION OF HIGHWAYS
DEPARTMENT OF TRANSPORTATION
WORK ZONE TRAFFIC CONTROL

-L- BRAWLEY SCHOOL RD
PHASE I
STEP 2,3,4

5/1/2023
User: Traffic Transportation Management Plan\TCP\PLAN SHEETS\VR-3833C-TMP-12-PHASE I\STEP 2.dgn
angood

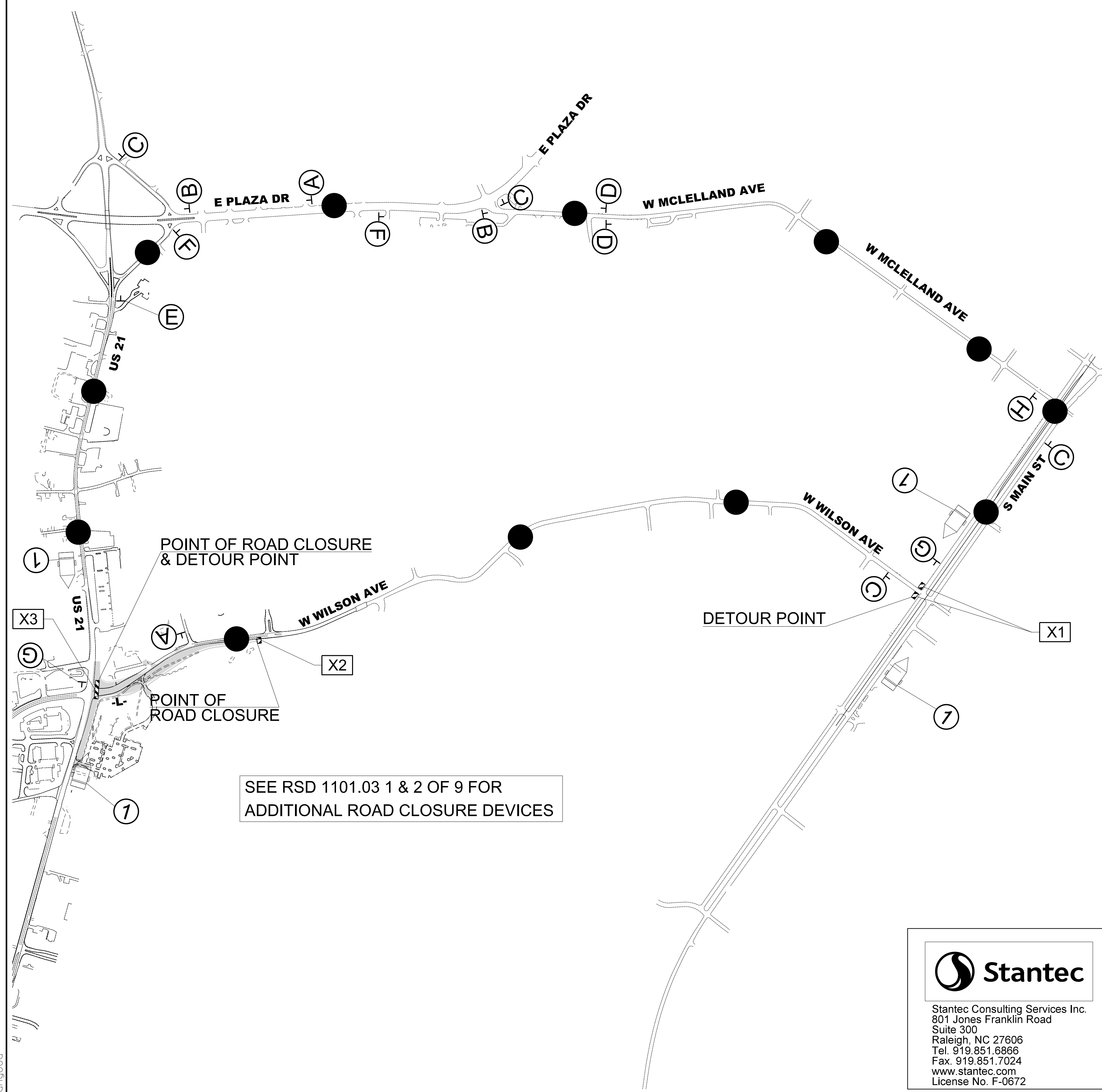
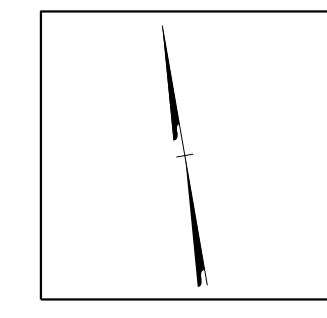

SEE RSD 1101.03 1 & 2 OF 9 FOR
ADDITIONAL ROAD CLOSURE DEVICES

A DETOUR M4-8 24"x12" W WILSON AVE M5-1 21"x15"	B DETOUR M4-8 24"x12" W WILSON AVE M5-2 21"x15"	C DETOUR M4-8 24"x12" W WILSON AVE M6-1L 21"x15"
D DETOUR M4-8 24"x12" W WILSON AVE M6-3 21"x15"	E DETOUR M4-8 24"x12" W WILSON AVE M6-2 21"x15"	F DETOUR M4-8 24"x12" W WILSON AVE
G END DETOUR M4-8a 24"x18" W WILSON AVE	H DETOUR M4-8 24"x12" W WILSON AVE M6-1 21"x15"	

X1 R11-3 (60" x 30") ROAD CLOSED 1 MILE AHEAD LOCAL TRAFFIC ONLY M4-10R (48" x 18") TYPE III BARRICADE	X2 R11-2 (48" x 30") ROAD CLOSED TYPE III BARRICADE	X3 R11-2 (48" x 30") ROAD CLOSED M4-10L (48" x 18") TYPE III BARRICADE
---	---	---

CMS 1	MESSAGE 1 WEEK PRIOR TO ROAD CLOSING CHANGEABLE MESSAGE SIGN W. WILSON AVE. CLOSING MM/DD	MESSAGE DURING ROAD CLOSURE CHANGEABLE MESSAGE SIGN W. WILSON AVE. CLOSED FOLLOW DETOUR
--------------	--	--

Stantec Consulting Services Inc.
801 Jones Franklin Road
Suite 300
Raleigh, NC 27606
Tel. 919.851.6866
Fax. 919.851.7024
www.stantec.com
License No. F-0672

5/1/2023

**DOCUMENT NOT CONSIDERED FINAL
UNLESS ALL SIGNATURES COMPLETED**

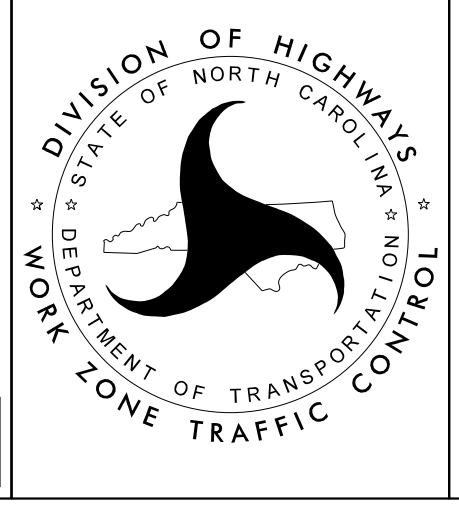

-L- WILSON AVE
DETOUR ROUTE

5/1/2023 L:\Traffic\Transportation Management Plan\TCP\PLAN SHEETS\IR-3833C-TMP-12A-DETOUR-ROUTE-L- WILSON AVE.dgn angood

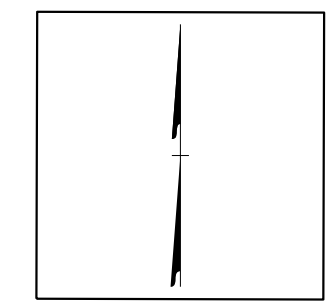

NOTE: SEE TMP-12A FOR DETOUR ROUTE

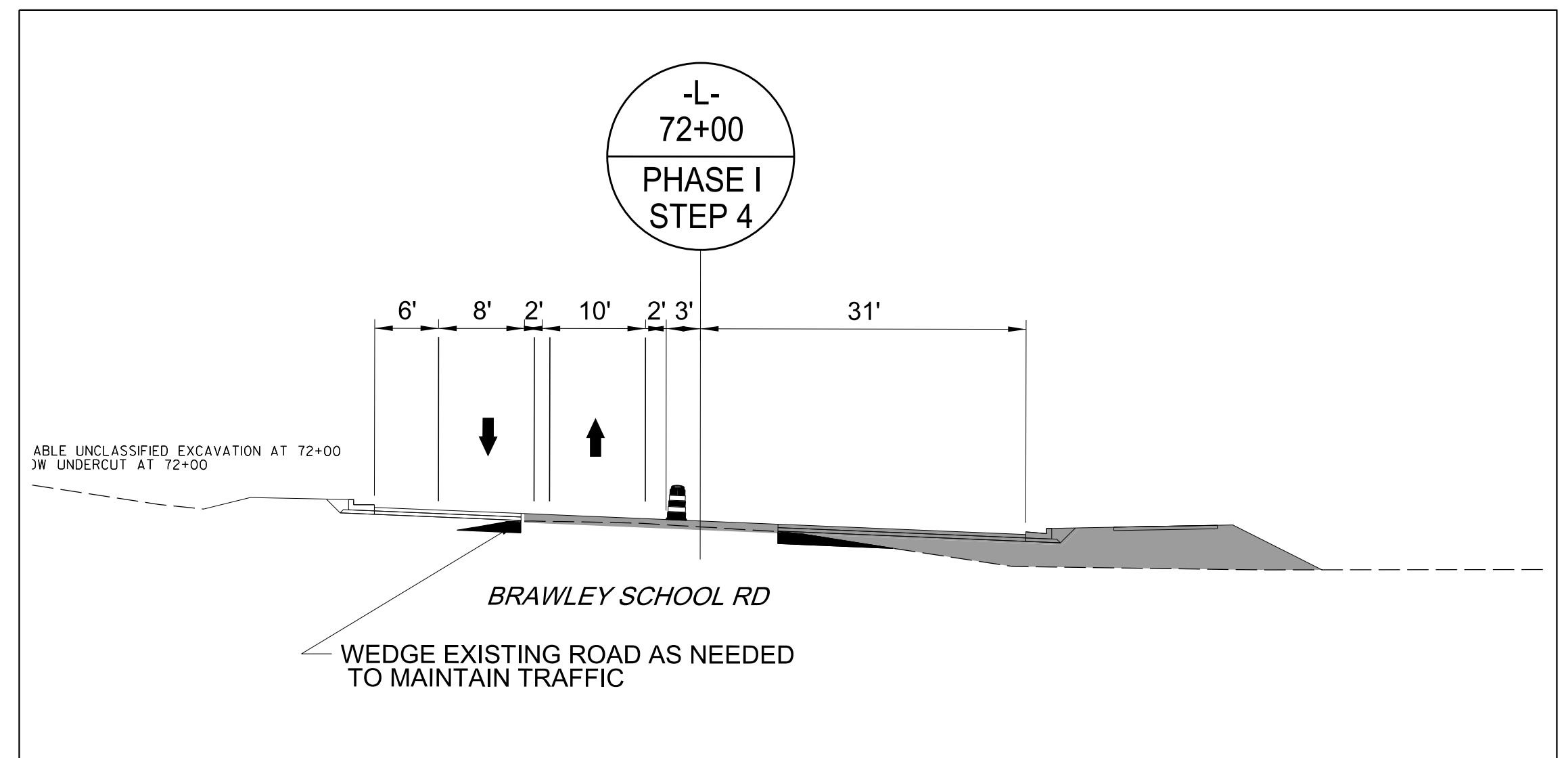
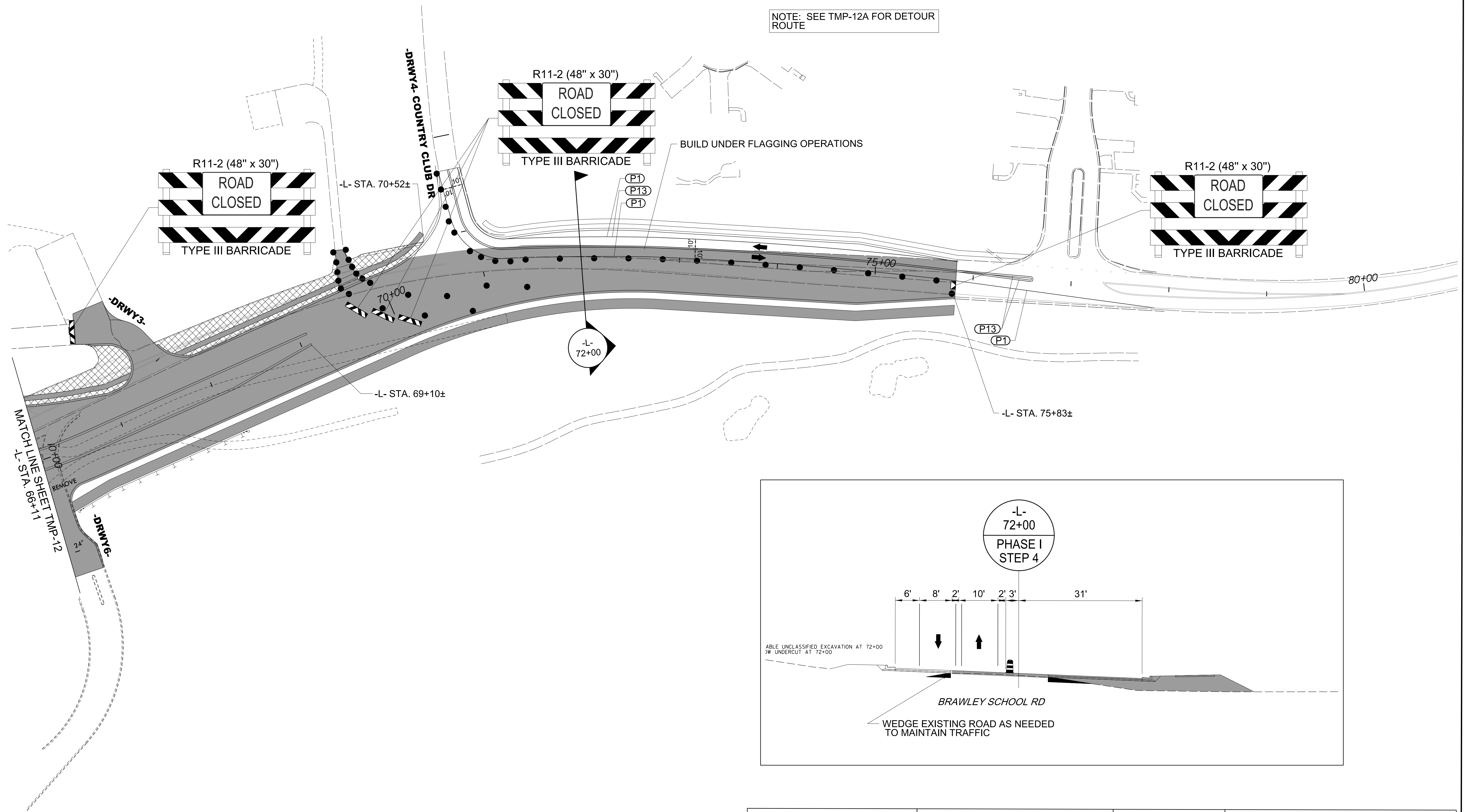

5/1/2023
 U:\Traffic\Transportation Management Plan\TCP\PLAN SHEETS\NR-3833C_TMP_13_PHASE 1_STEP 2.dgn
 gngood

Stantec Consulting Services Inc.
 801 Jones Franklin Road
 Suite 300
 Raleigh, NC 27606
 Tel. 919.851.6866
 Fax. 919.851.7024
 www.stantec.com
 License No. F-0672

5/1/2023

**DOCUMENT NOT CONSIDERED FINAL
UNLESS ALL SIGNATURES COMPLETED**

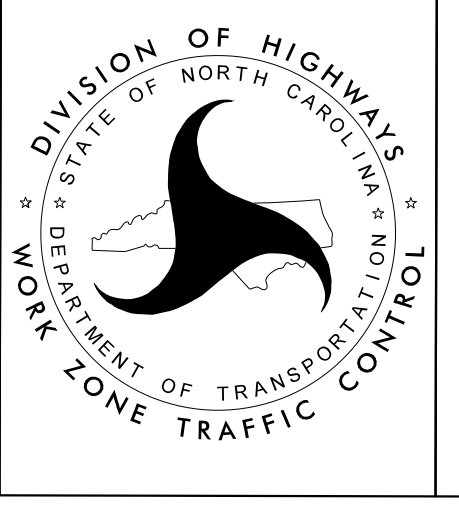

**-L- BRAWLEY SCHOOL RD
 PHASE I
 STEP 3,4**

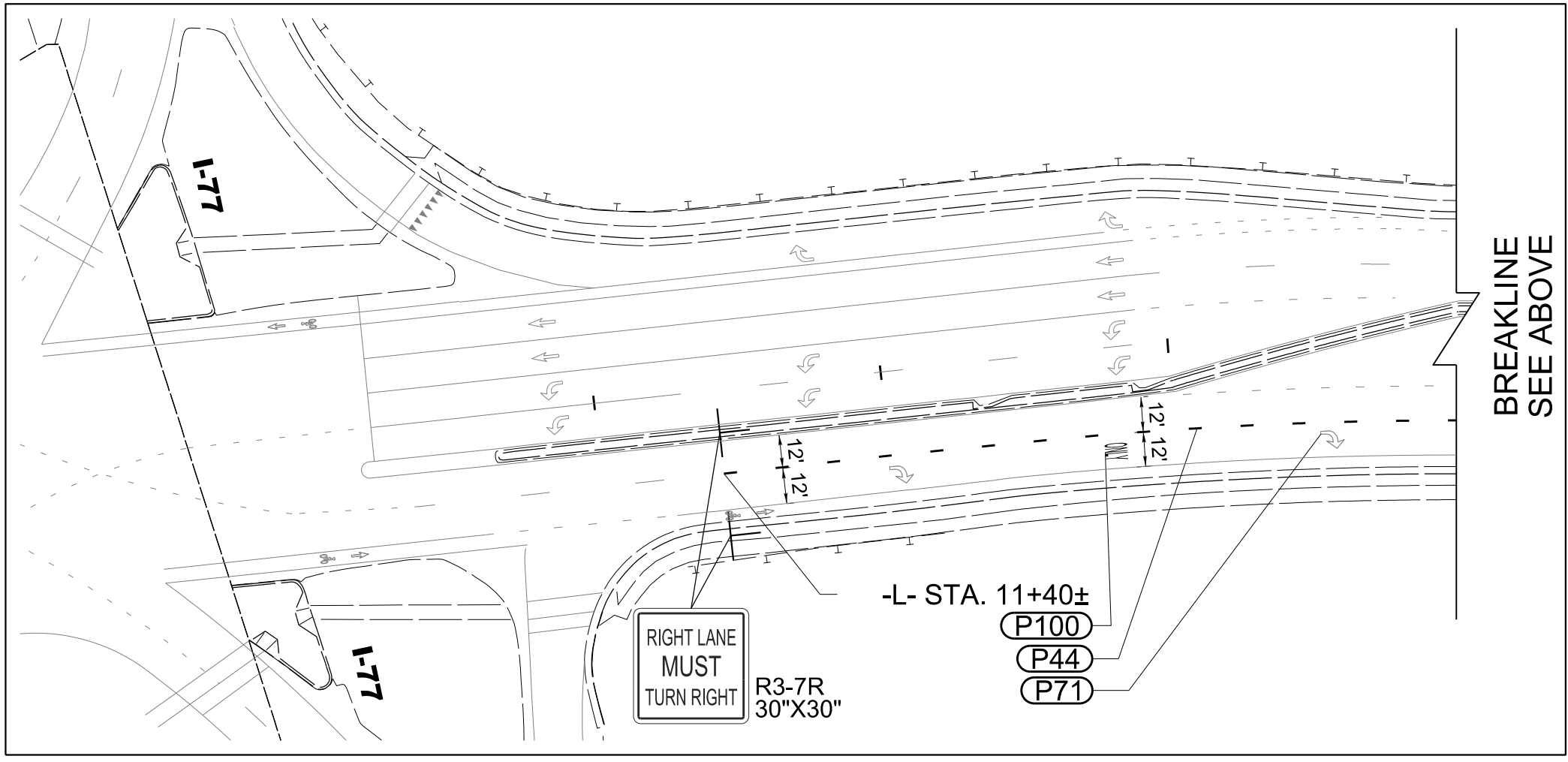
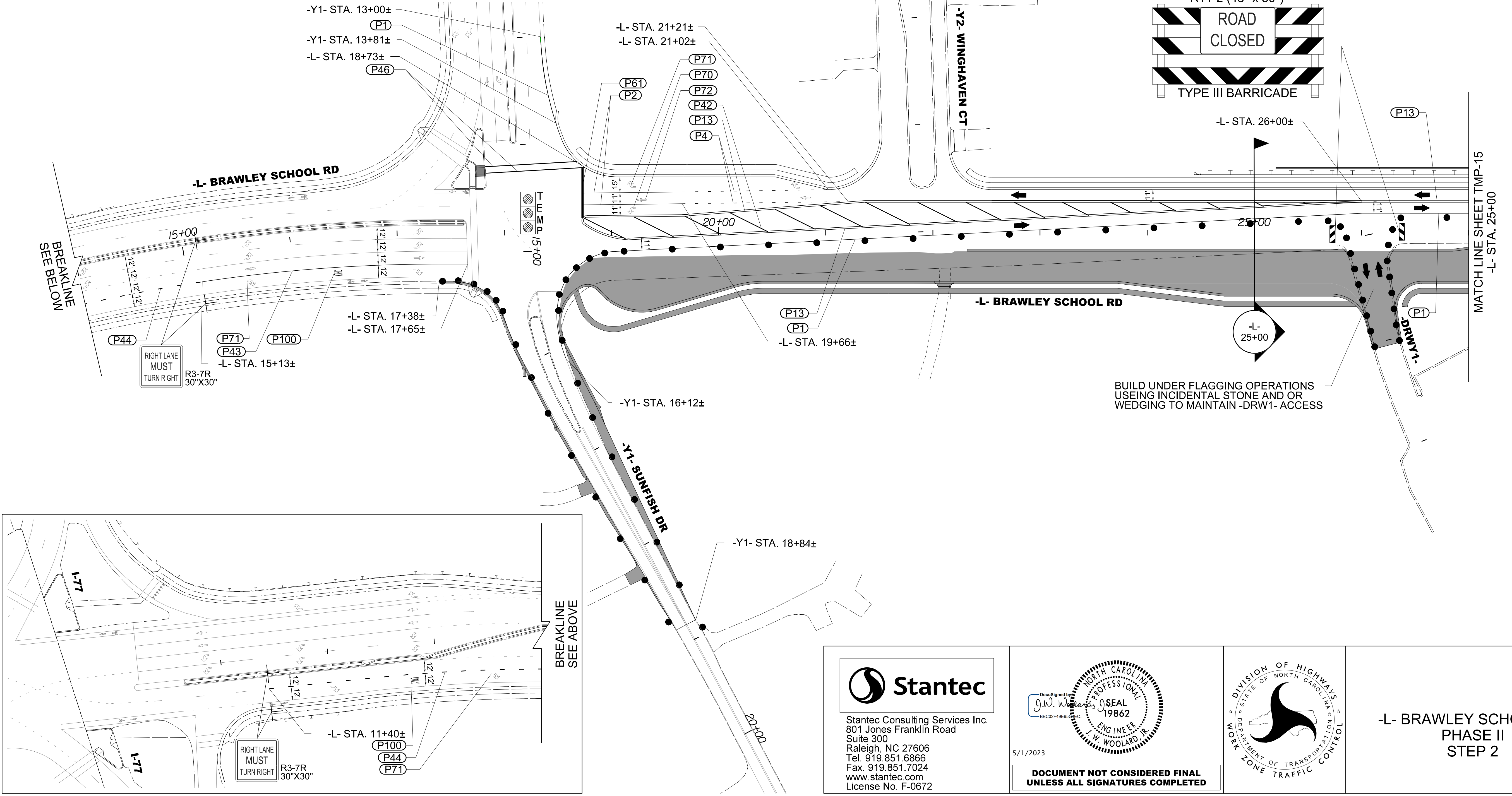
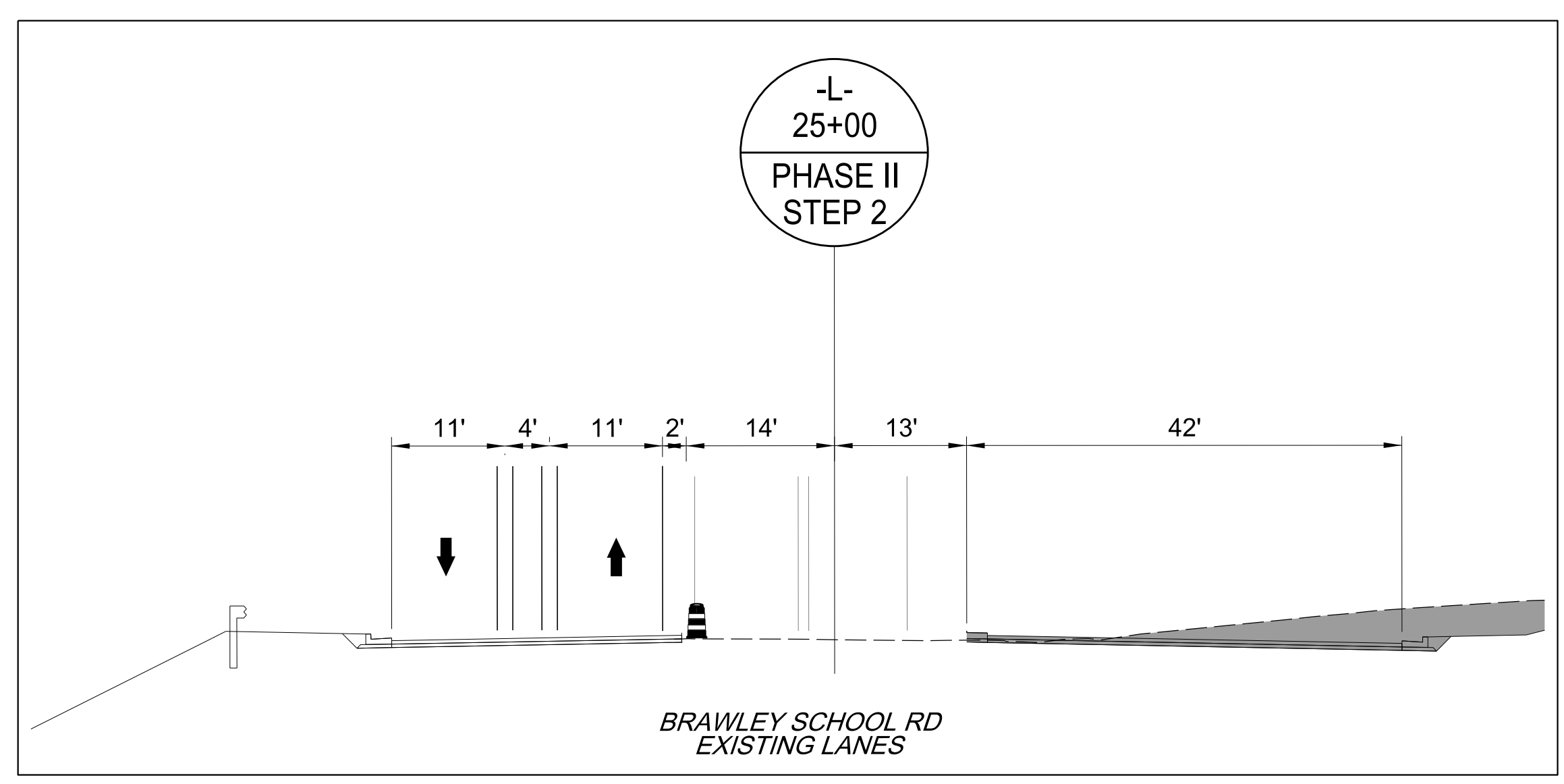
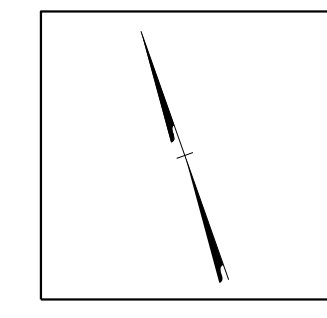

5/1/2023
L:\Traffic\Transportation Management Plan\TCP\PLAN SHEETS\IR-3833C-TMP-14-PHASE 2.dgn
angood

Stantec
Stantec Consulting Services Inc.
801 Jones Franklin Road
Suite 300
Raleigh, NC 27606
Tel. 919.851.6866
Fax. 919.851.7024
www.stantec.com
License No. F-0672

DocuSigned by:
J.W. Woolard
19862
ENGINEER
W. WOOLARD, R.
5/1/2023

**DOCUMENT NOT CONSIDERED FINAL
UNLESS ALL SIGNATURES COMPLETED**

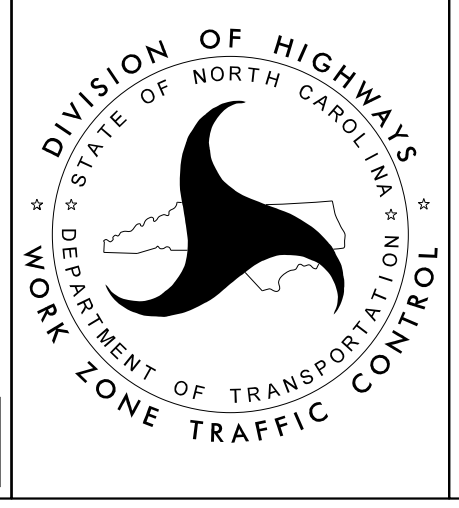

**-L- BRAWLEY SCHOOL RD
PHASE II
STEP 2**

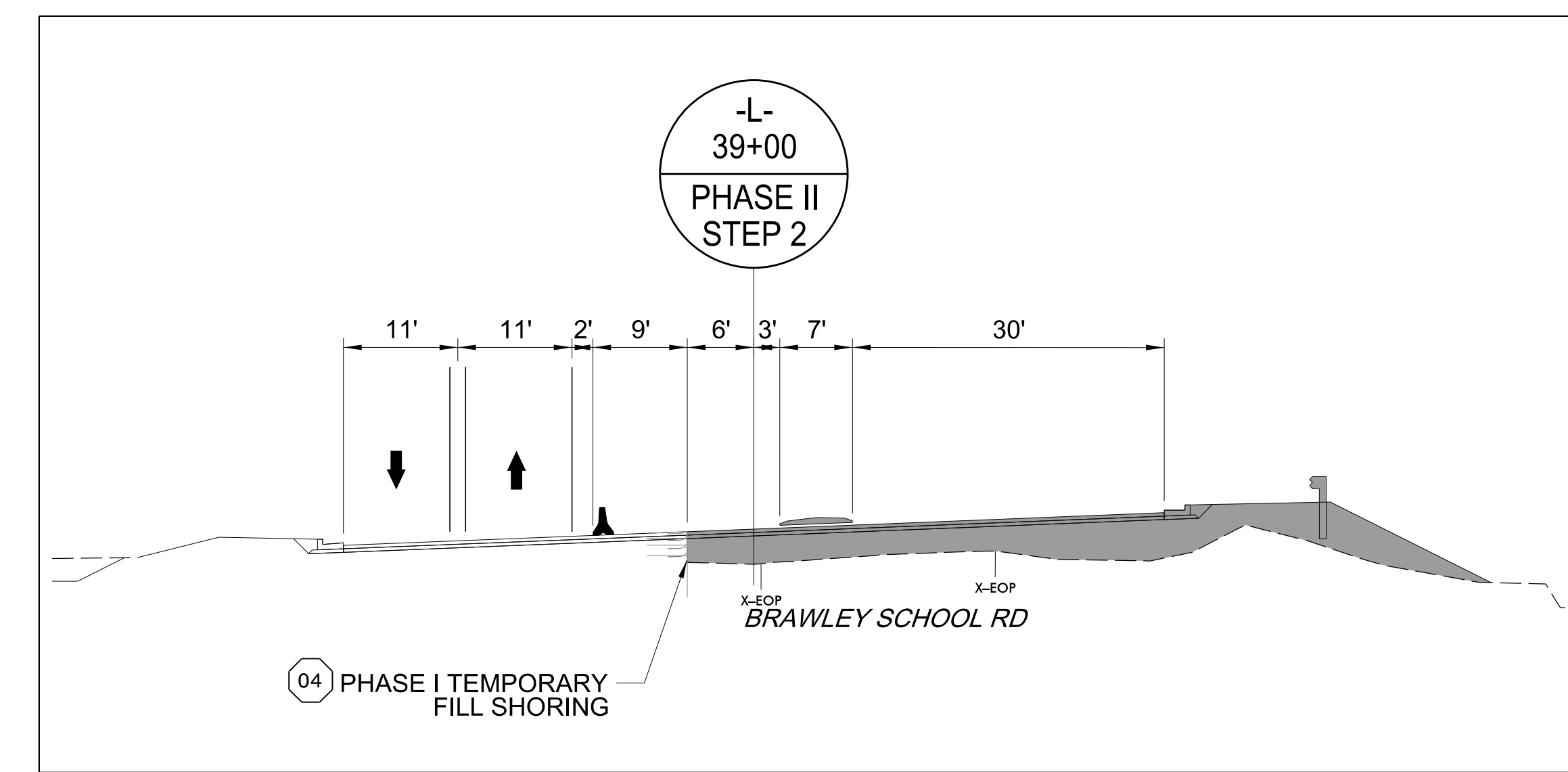
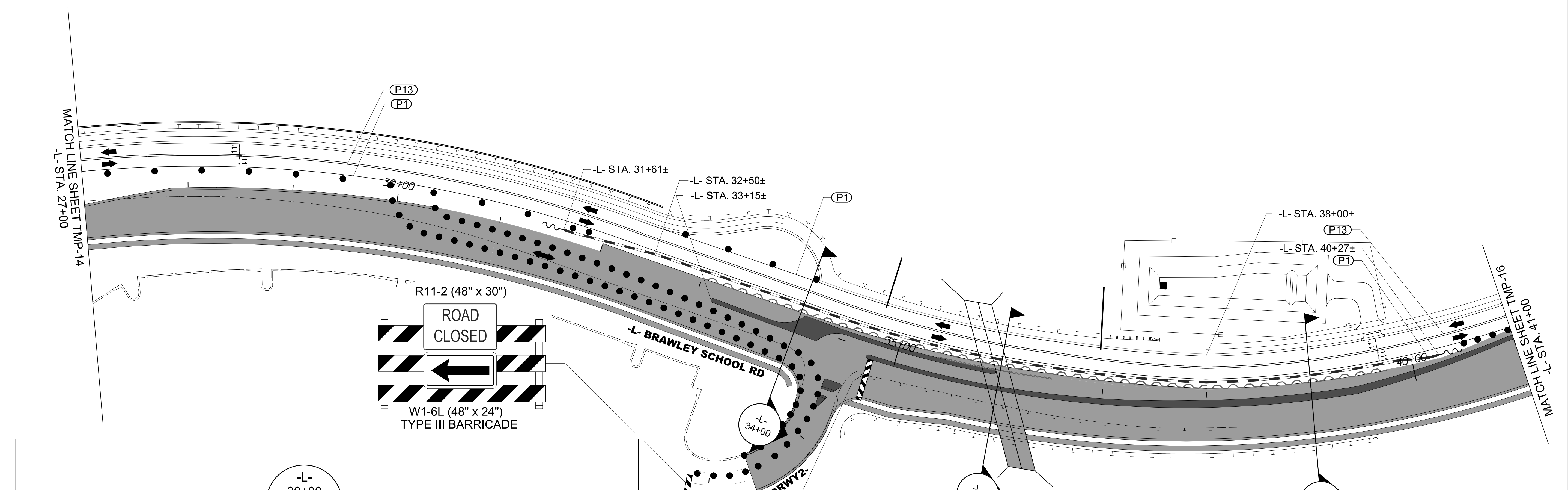
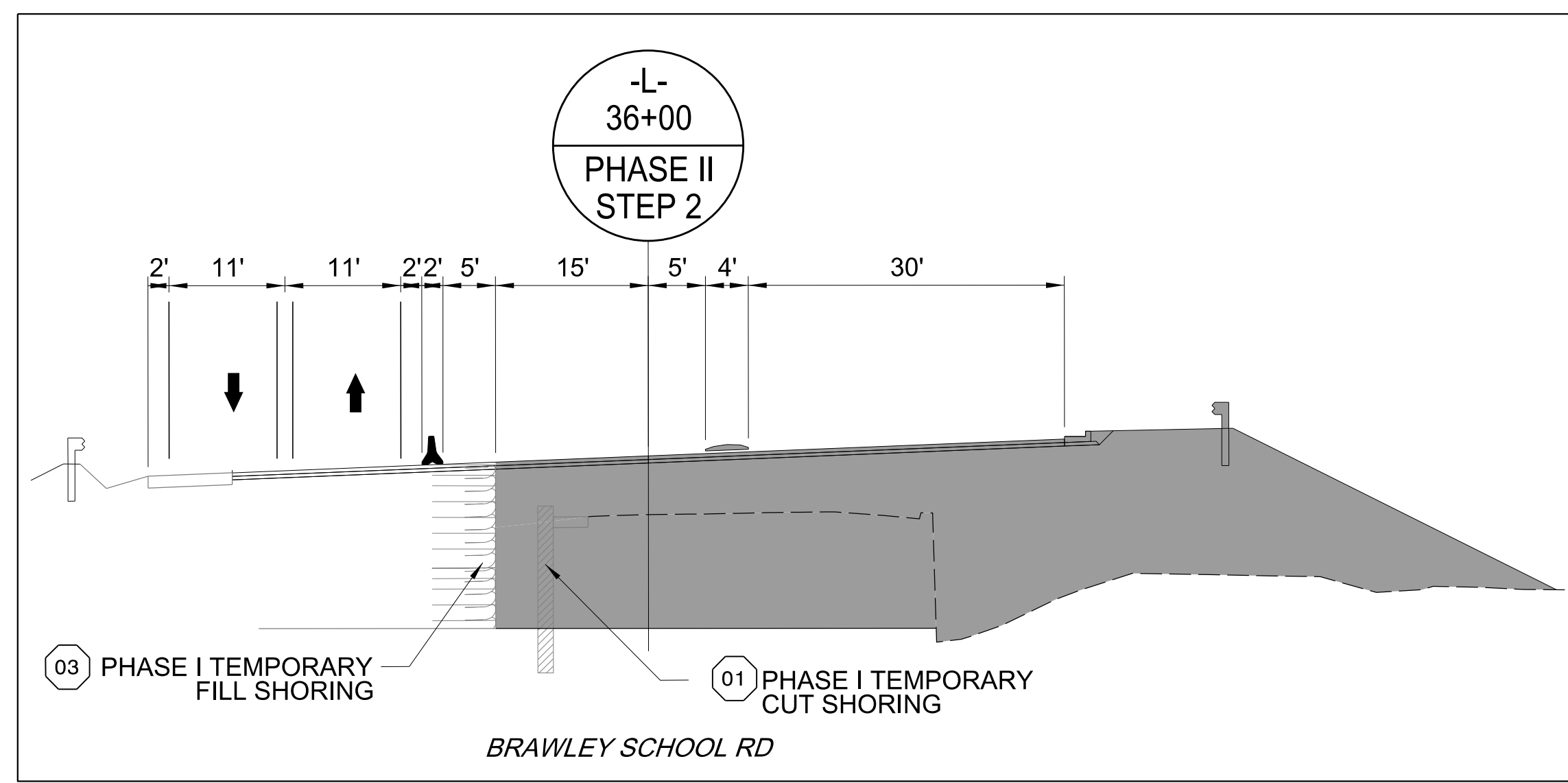
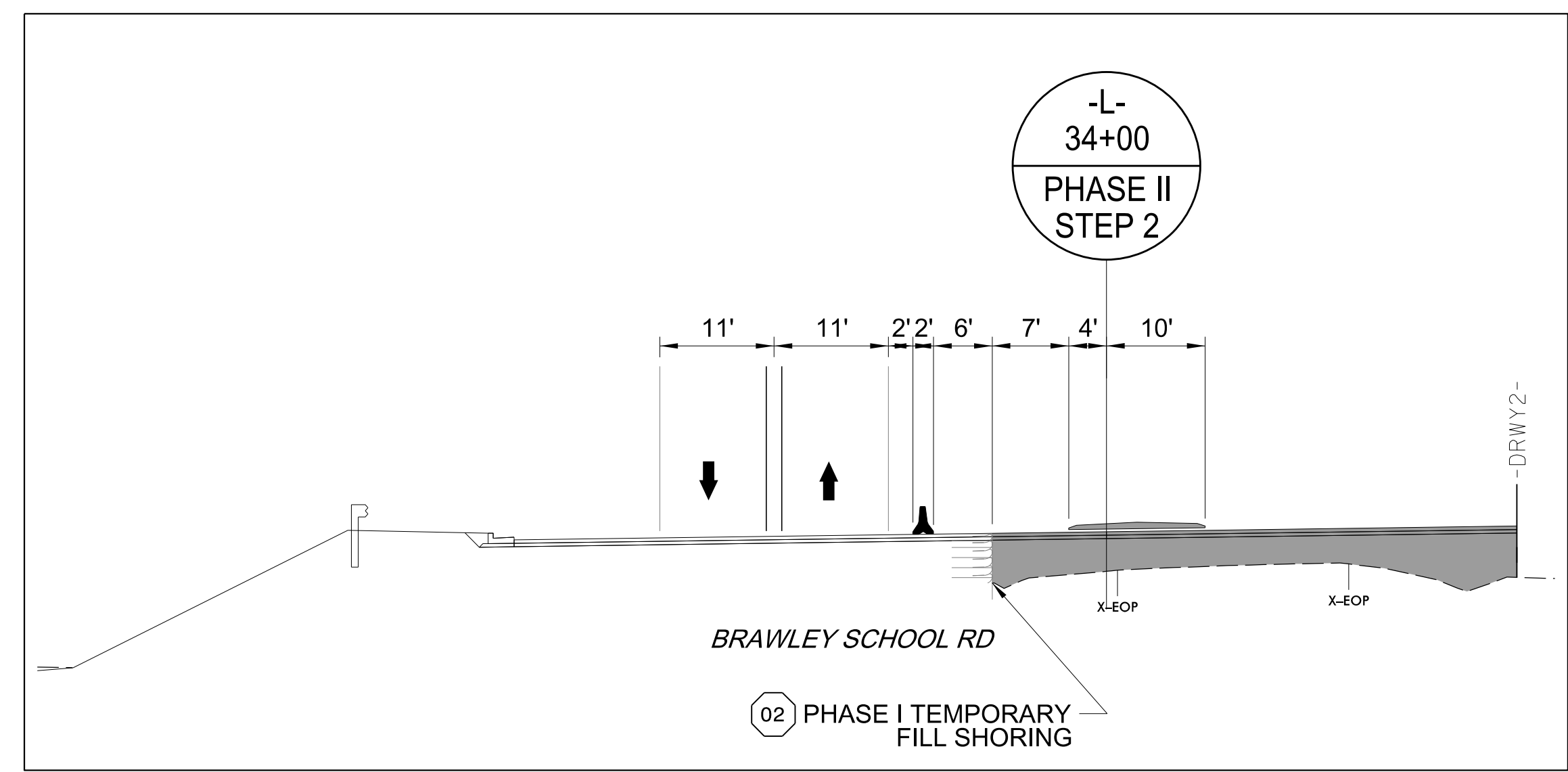
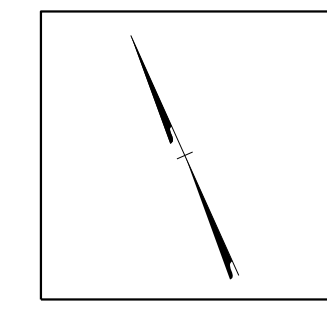

NOTE: USING INCIDENTAL STONE AS NEEDED. MAINTAIN ACCESS TO -DRWY2- AT ALL TIMES AS DIRECTED BY THE ENGINEER.

5/1/2023
 U:\Traffic\Transportation Management Plan\TCP\PLAN SHEETS\IR-3833C-TMP-15-PHASE 2.dgn
 angood

Stantec
 Stantec Consulting Services Inc.
 801 Jones Franklin Road
 Suite 300
 Raleigh, NC 27606
 Tel. 919.851.6866
 Fax. 919.851.7024
 www.stantec.com
 License No. F-0672

5/1/2023
 DOCUMENT NOT CONSIDERED FINAL
 UNLESS ALL SIGNATURES COMPLETED

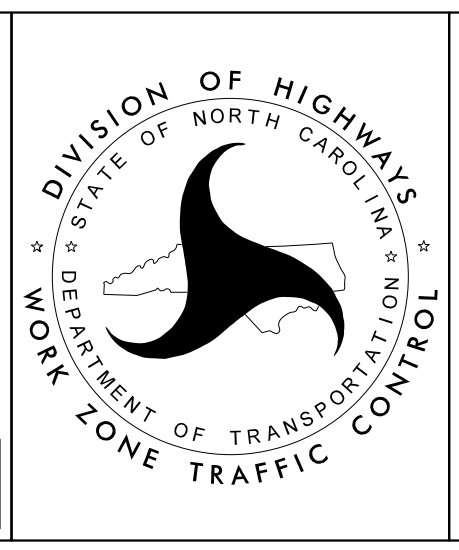

-L- BRAWLEY SCHOOL RD
 PHASE II
 STEP 2

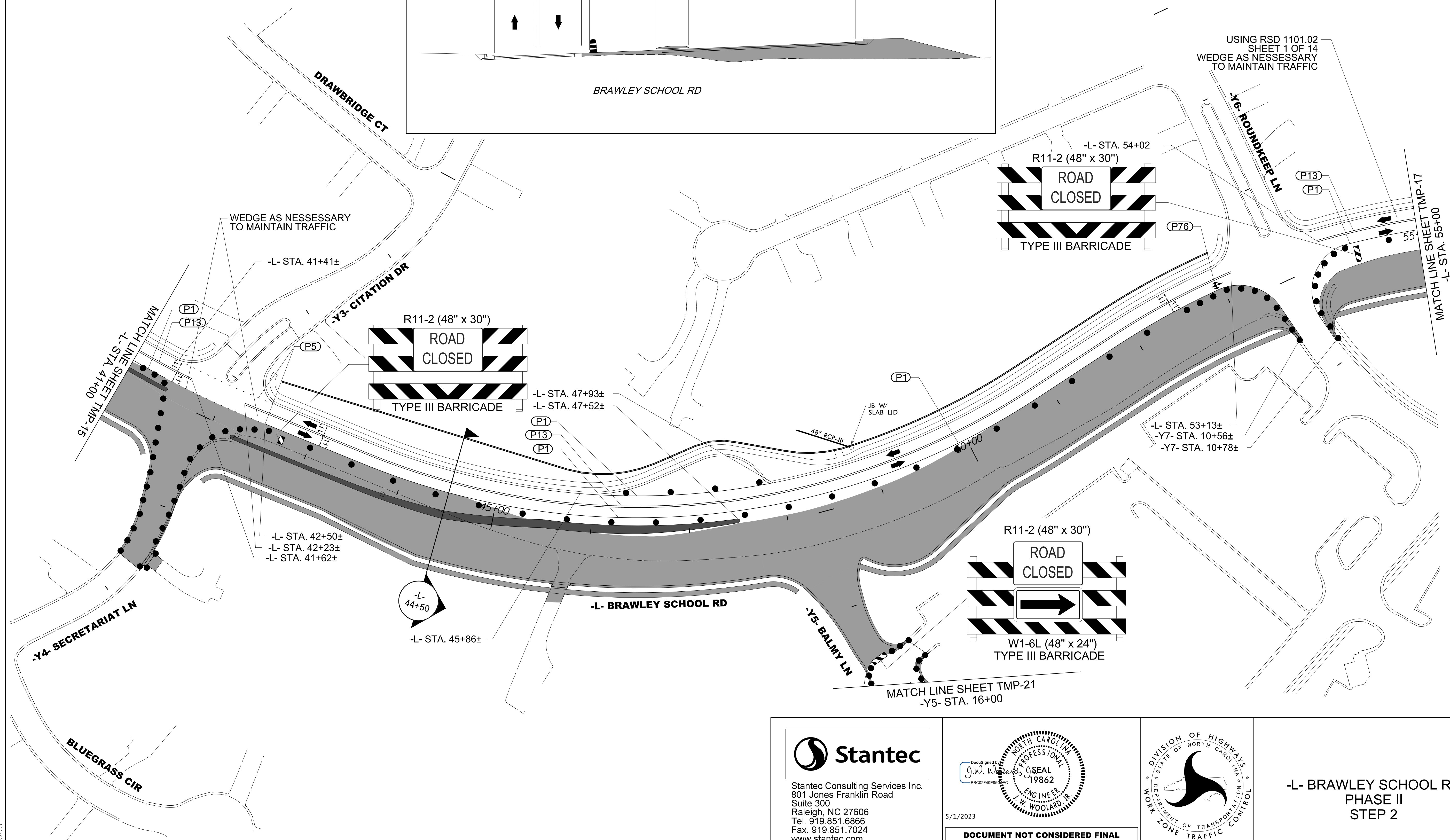
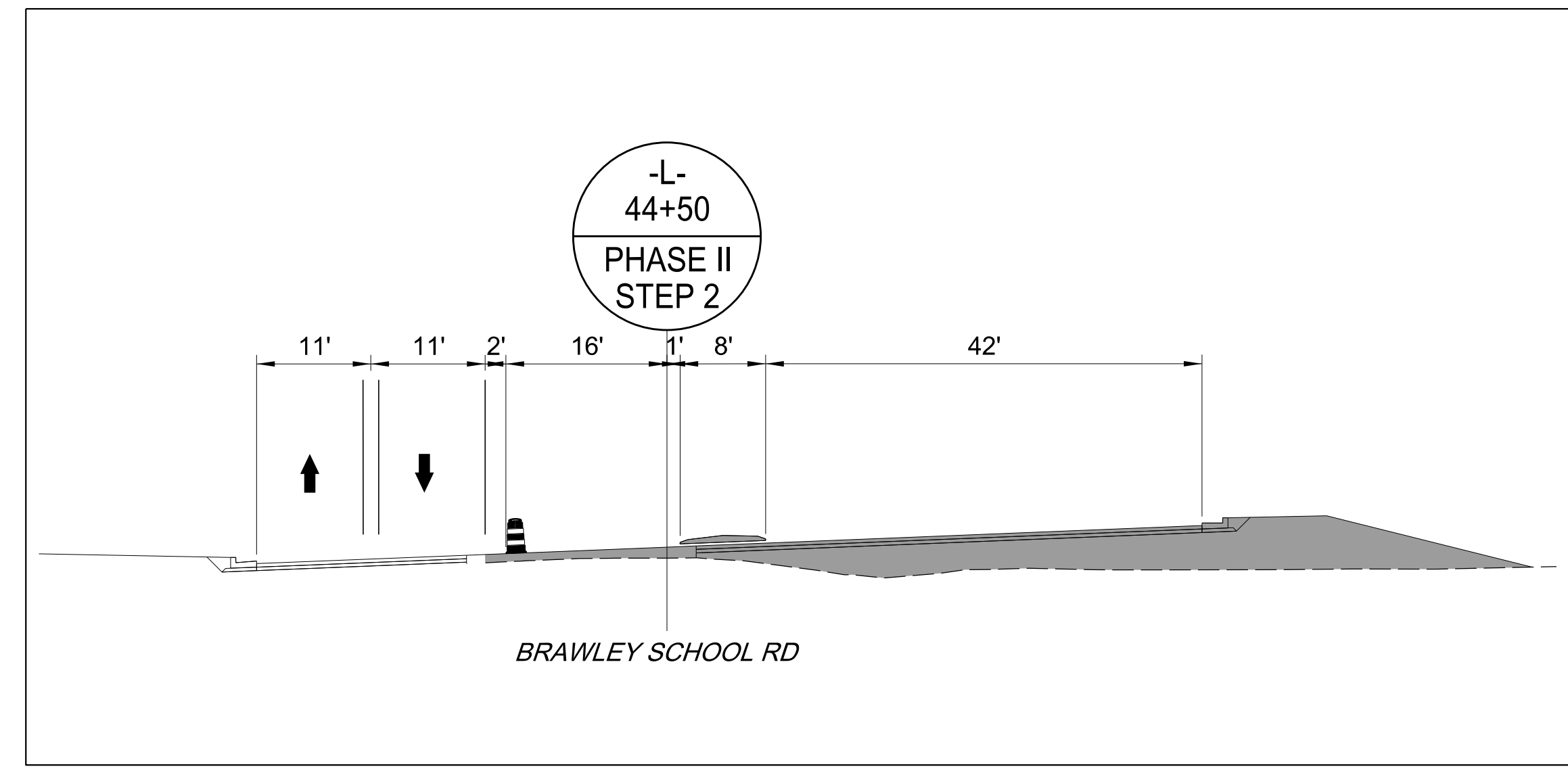
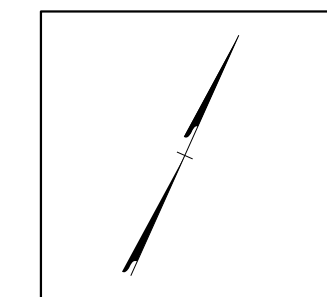

5/1/2023
 U:\Traffic\Transportation Management Plan\TCP\PLAN SHEETS\VR-3833C-TMP-16-PHASE 2.dgn
 angood

Stantec
 Stantec Consulting Services Inc.
 801 Jones Franklin Road
 Suite 300
 Raleigh, NC 27606
 Tel. 919.851.6866
 Fax. 919.851.7024
 www.stantec.com
 License No. F-0672

5/1/2023

**DOCUMENT NOT CONSIDERED FINAL
 UNLESS ALL SIGNATURES COMPLETED**

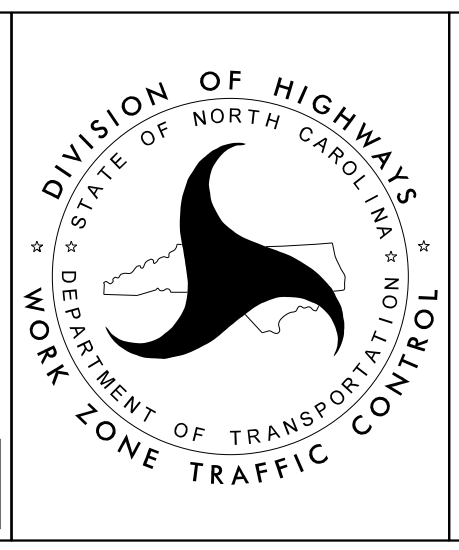

**-L- BRAWLEY SCHOOL RD
 PHASE II
 STEP 2**

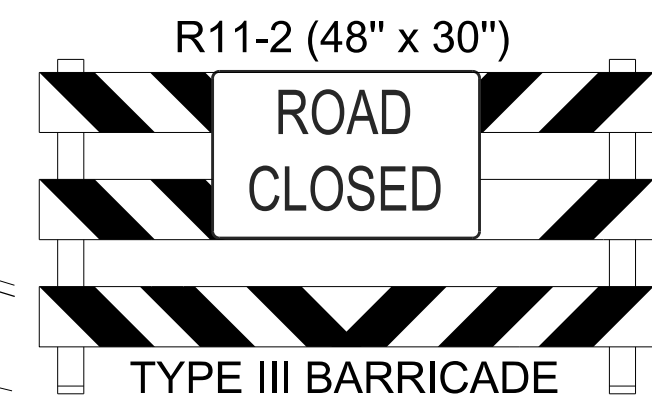
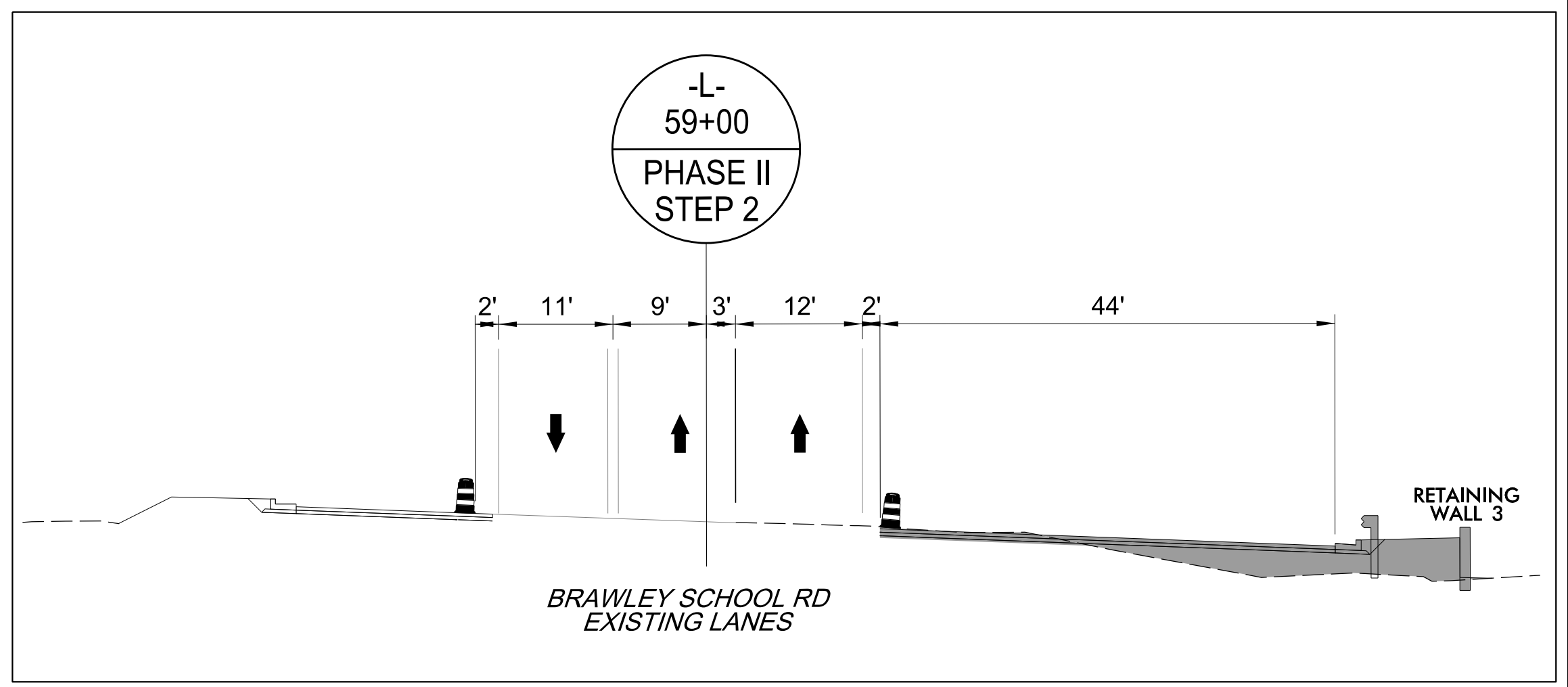
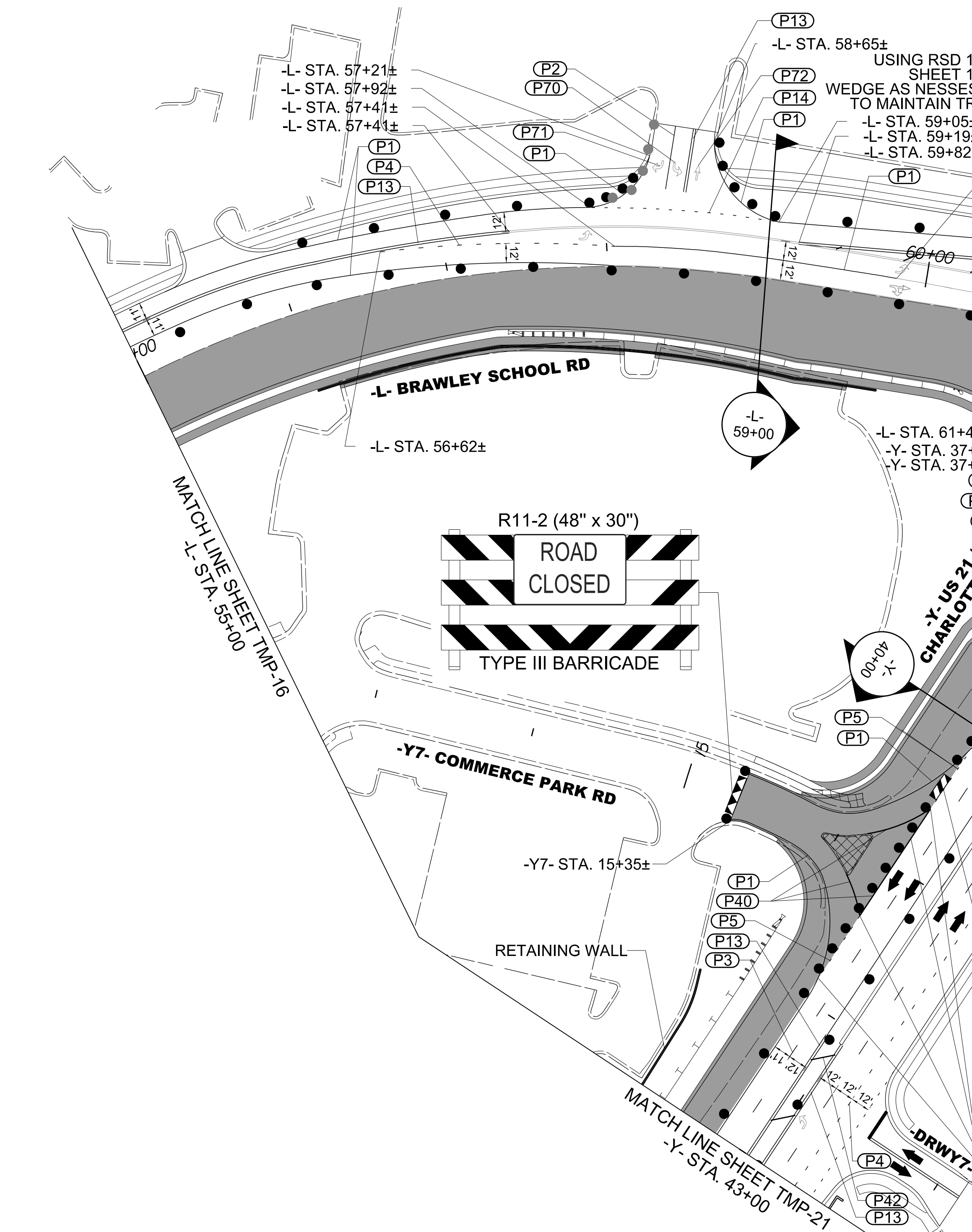
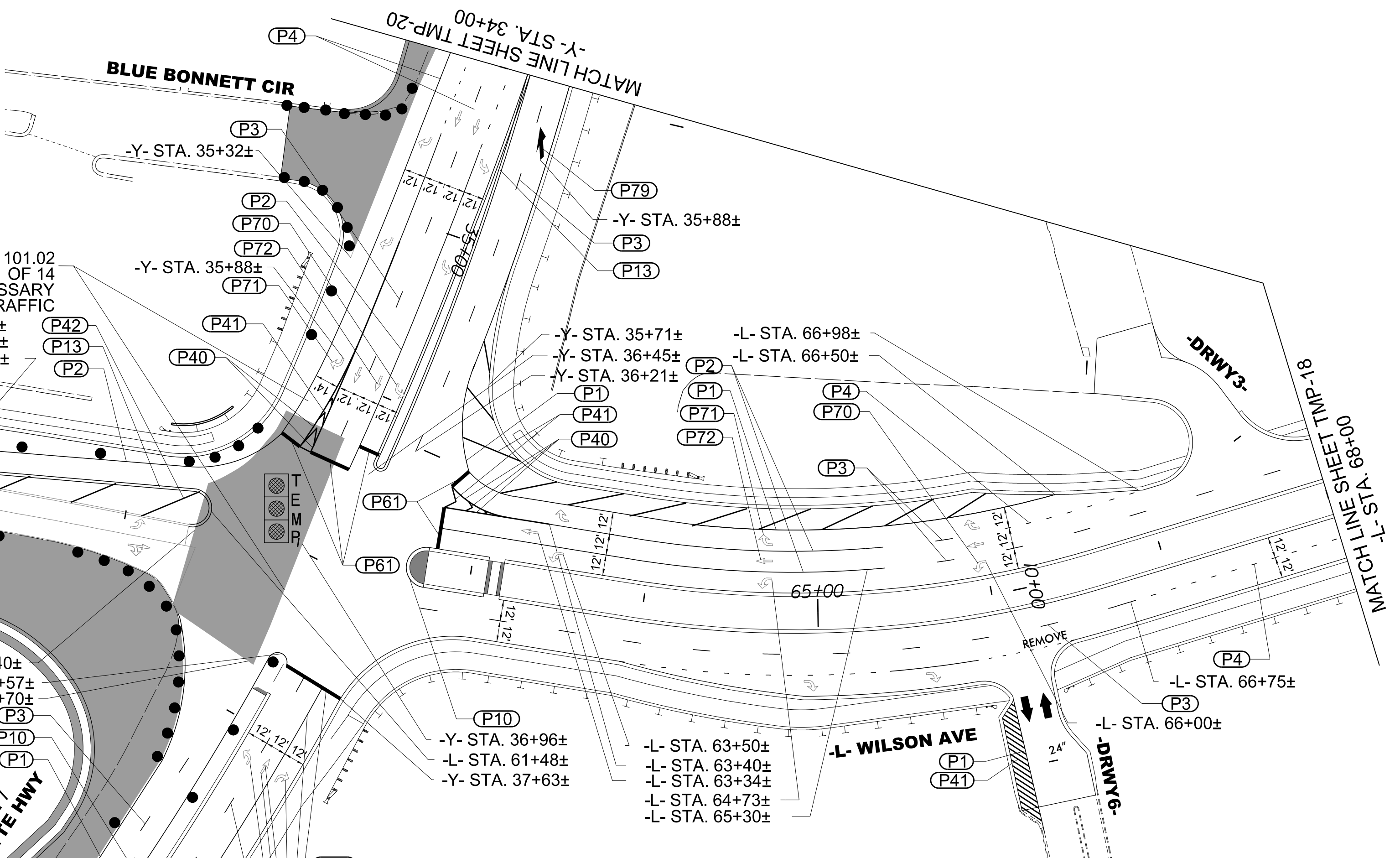
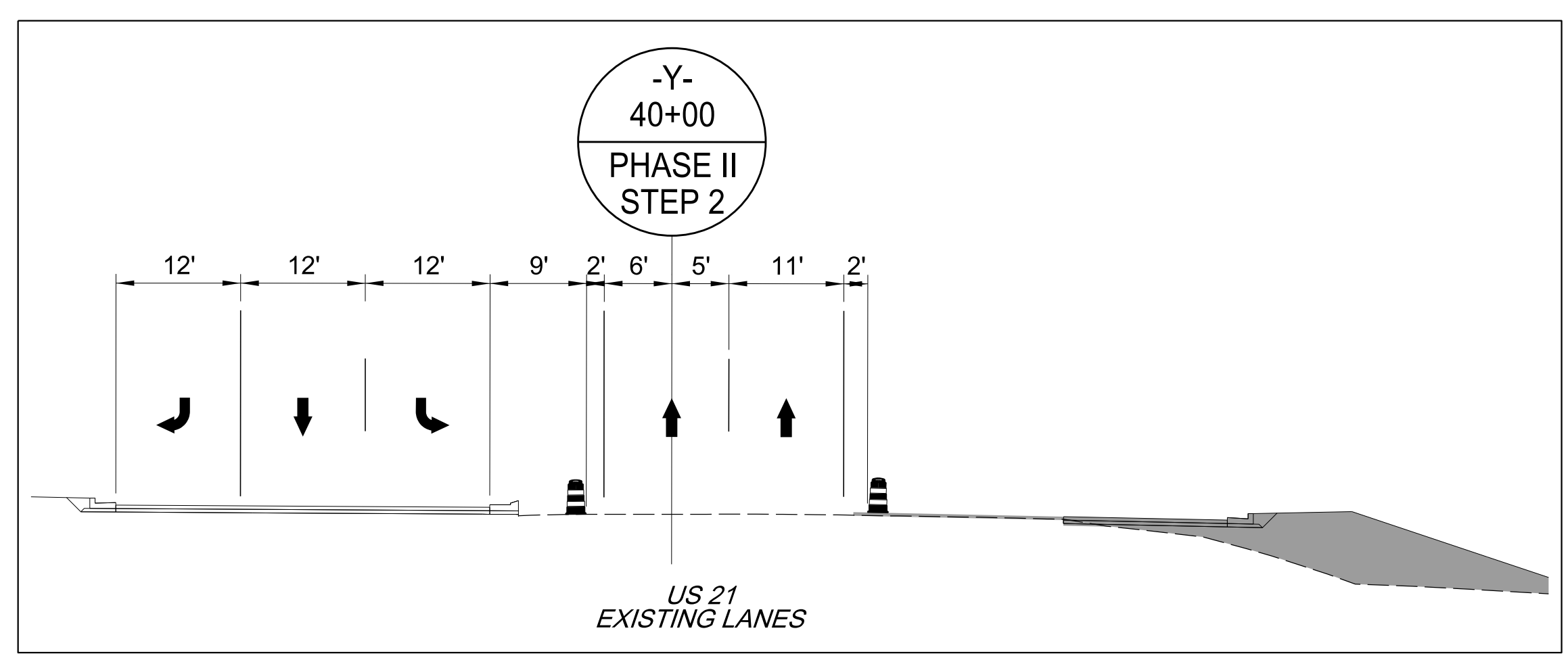

5/1/2023
L:\Traffic\Transportation Management\Plan\TCP\PLAN SHEETS\VR-3833C-TMP_17_PHASE 2.dgn
angood

Stantec
Stantec Consulting Services Inc.
801 Jones Franklin Road
Suite 300
Raleigh, NC 27606
Tel. 919.851.6866
Fax. 919.851.7024
www.stantec.com
License No. F-0672

5/1/2023
DOCUMENT NOT CONSIDERED FINAL
UNLESS ALL SIGNATURES COMPLETED

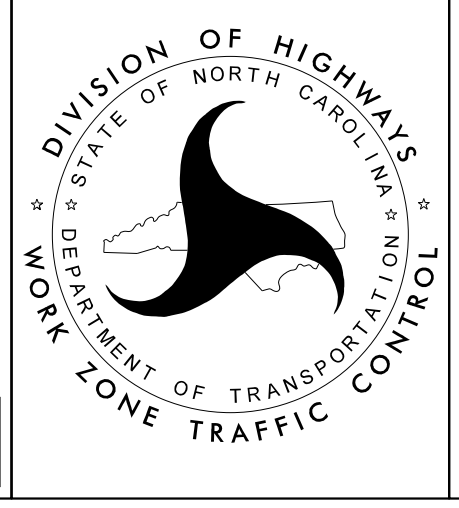

**-L- BRAWLEY SCHOOL RD
PHASE II
STEP 1,2,3**

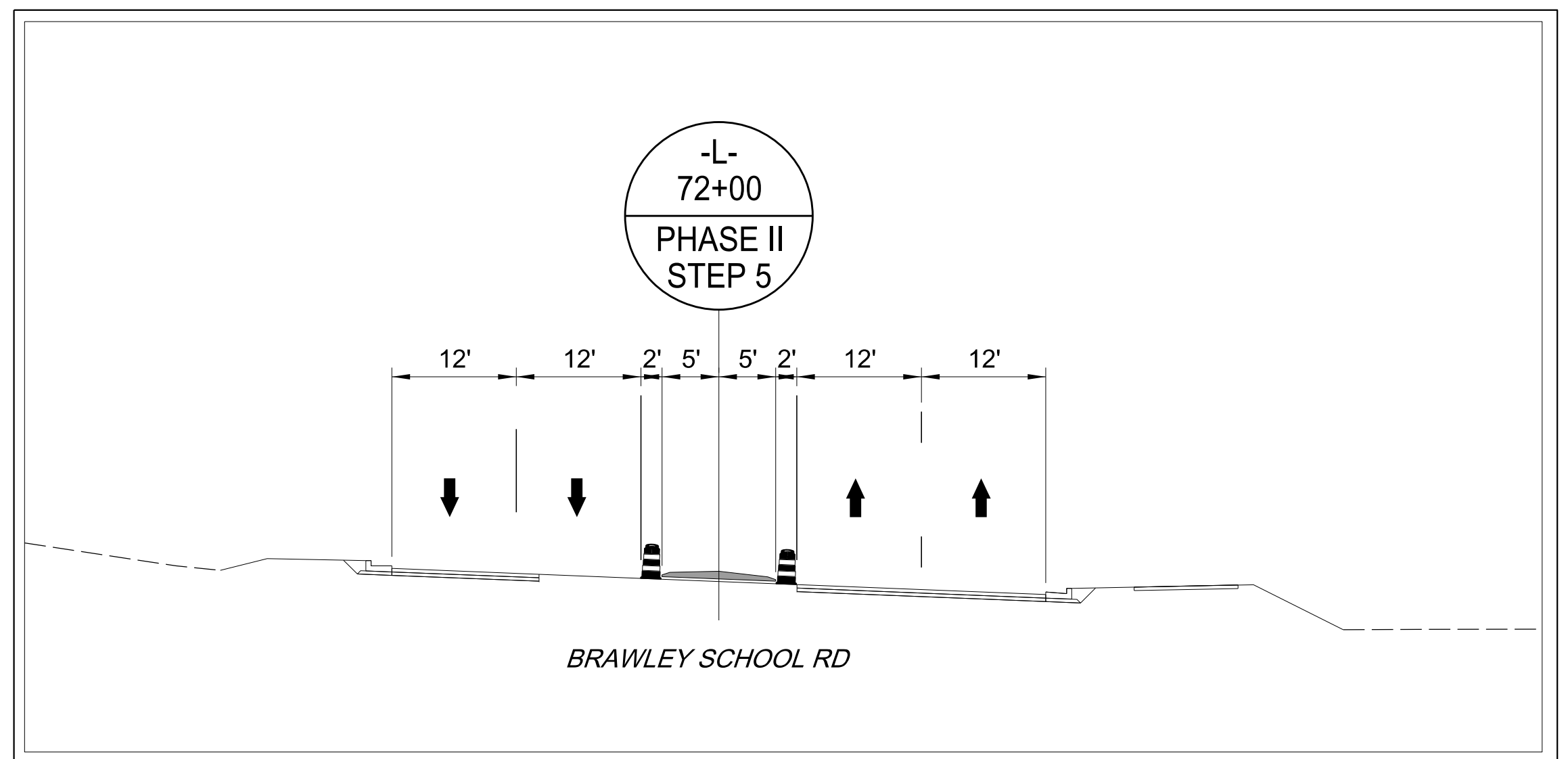
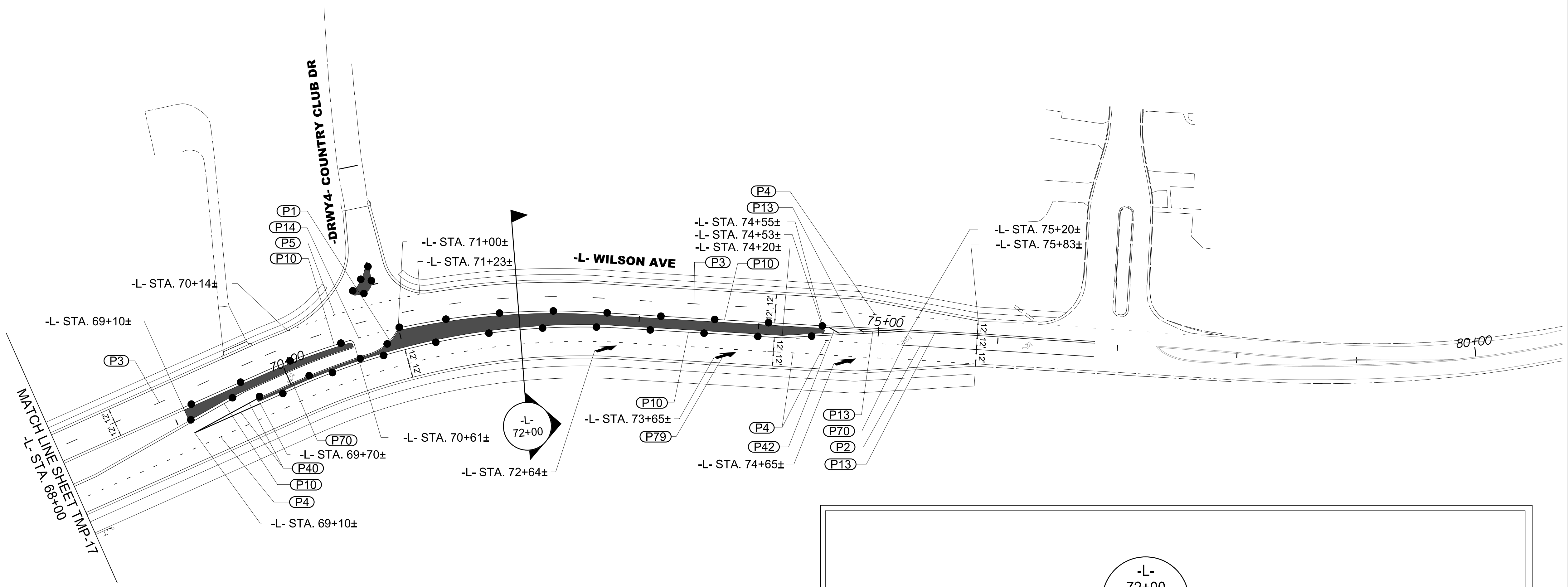
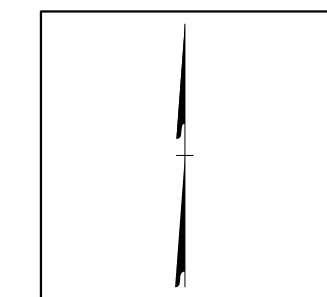

5/24/2023
 U:\Traffic\Transportation Management\Plan\TCP\PLAN SHEETS\IR-3833C-TMP-18-PHASE 2.dgn
 angood

Stantec Consulting Services Inc.
 801 Jones Franklin Road
 Suite 300
 Raleigh, NC 27606
 Tel. 919.851.6866
 Fax. 919.851.7024
 www.stantec.com
 License No. F-0672

5/24/2023
**DOCUMENT NOT CONSIDERED FINAL
 UNLESS ALL SIGNATURES COMPLETED**

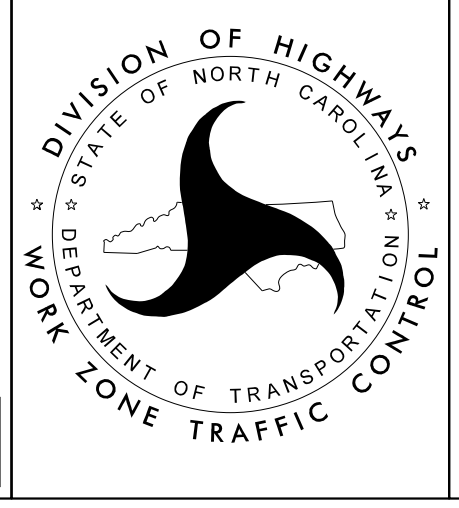

**-L- BRAWLEY SCHOOL RD
 PHASE II
 STEP 5**

PROJ. REFERENCE NO.	SHEET NO.
R-3833C	TMP-19

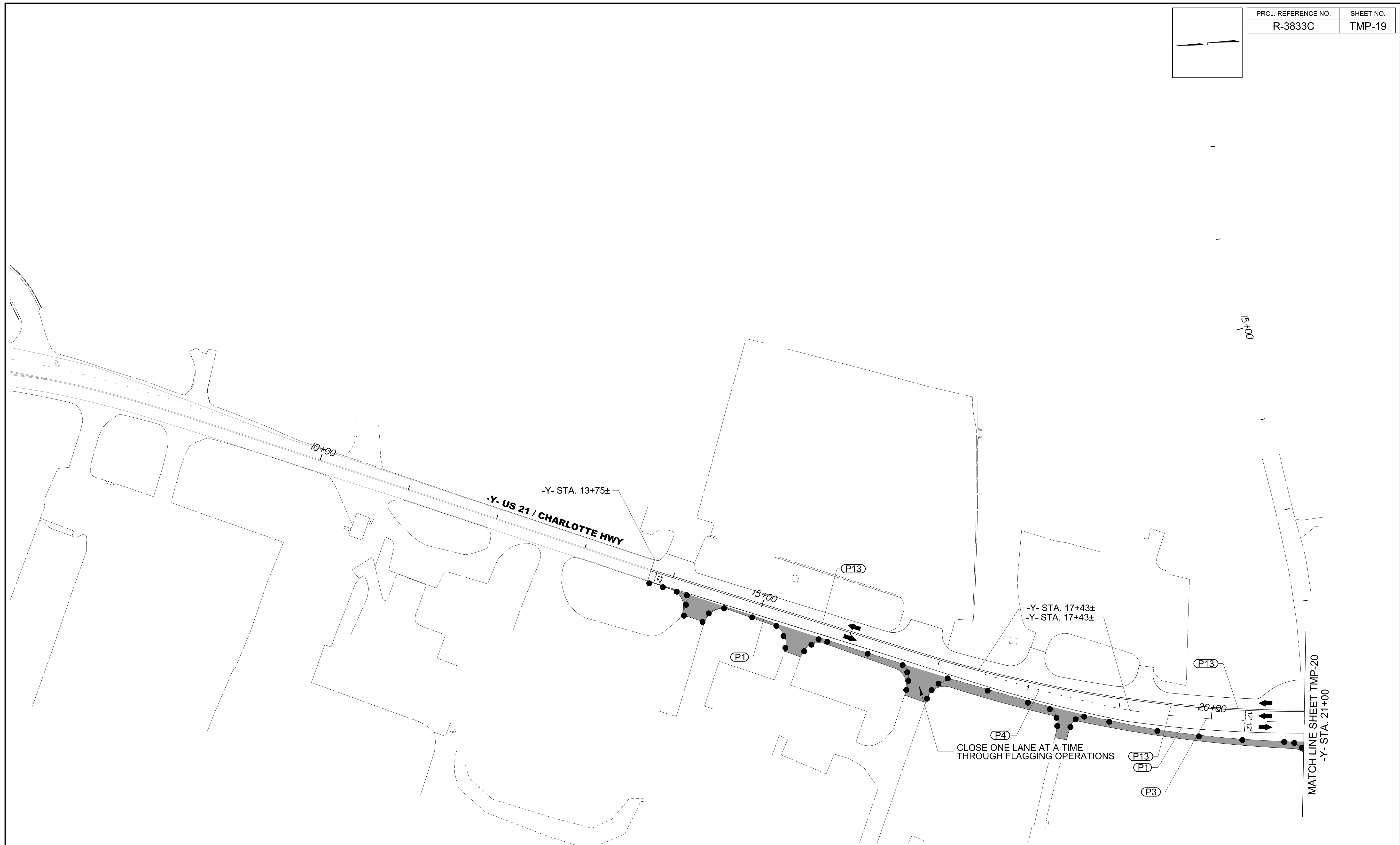
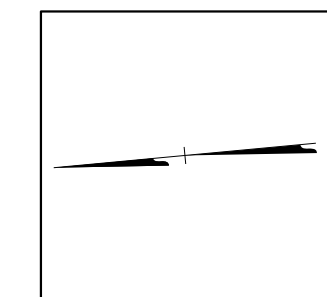

5/1/2023
 U:\Traffic\Transportation Management\Plan\TCP\PLAN SHEETS\IR-3833C-TMP_19_PHASE 2.dgn
 angood

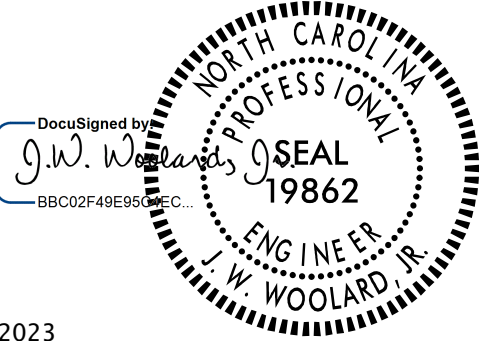
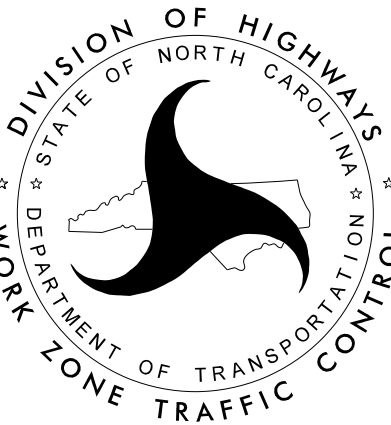
 <p>Stantec Consulting Services Inc. 801 Jones Franklin Road Suite 300 Raleigh, NC 27606 Tel. 919.851.6866 Fax. 919.851.7024 www.stantec.com License No. F-0672</p>	<p>5/1/2023</p>  <p>DOCUMENT NOT CONSIDERED FINAL UNLESS ALL SIGNATURES COMPLETED</p>		<p align="center">-L- BRAWLEY SCHOOL RD PHASE II STEP 2</p>
---	--	---	--

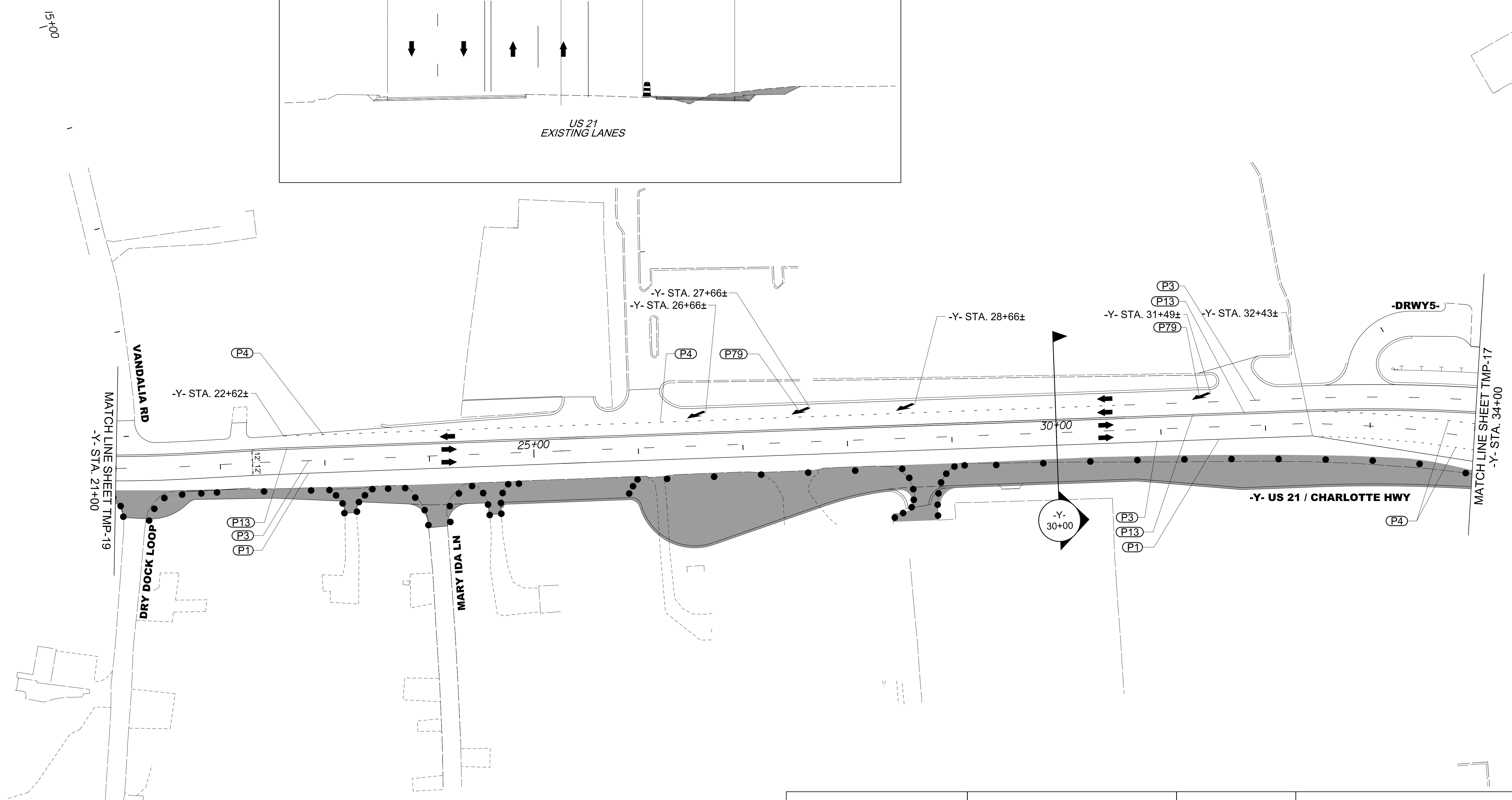
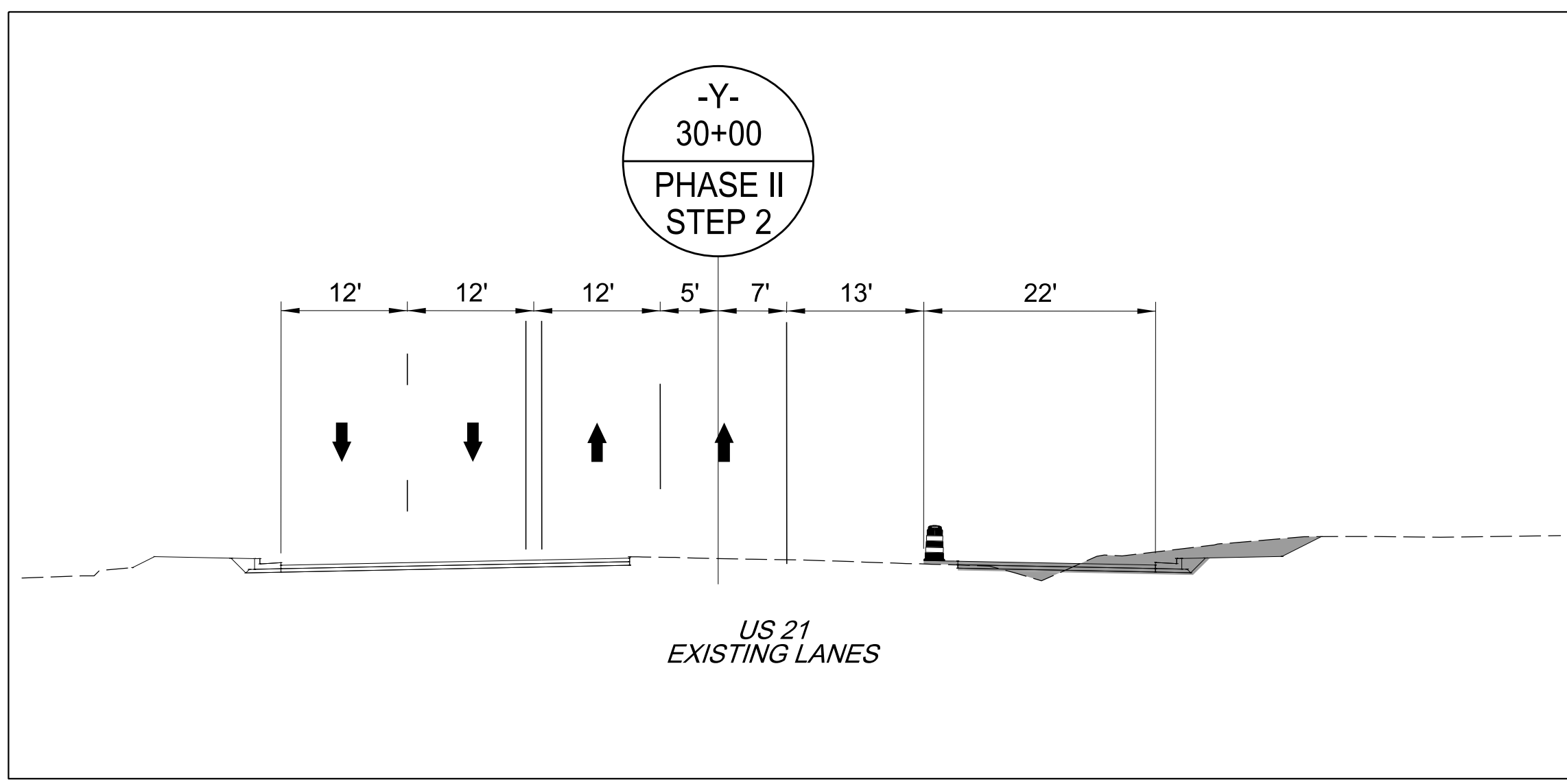
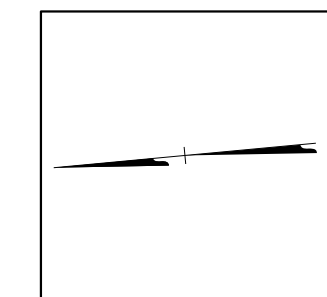

5/1/2023
 U:\Traffic\Transportation Management\Plan\TCP\PLAN SHEETS\IR-3833C-TMP_20_PHASE 2.dgn
 angood

Stantec Consulting Services Inc.
 801 Jones Franklin Road
 Suite 300
 Raleigh, NC 27606
 Tel. 919.851.6866
 Fax. 919.851.7024
 www.stantec.com
 License No. F-0672

5/1/2023

**DOCUMENT NOT CONSIDERED FINAL
 UNLESS ALL SIGNATURES COMPLETED**

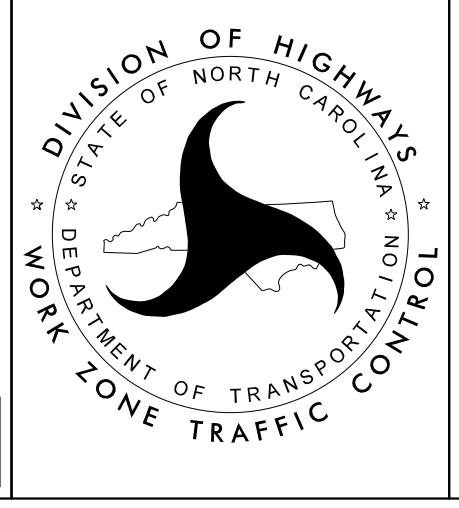

**-L- BRAWLEY SCHOOL RD
 PHASE II
 STEP 2**

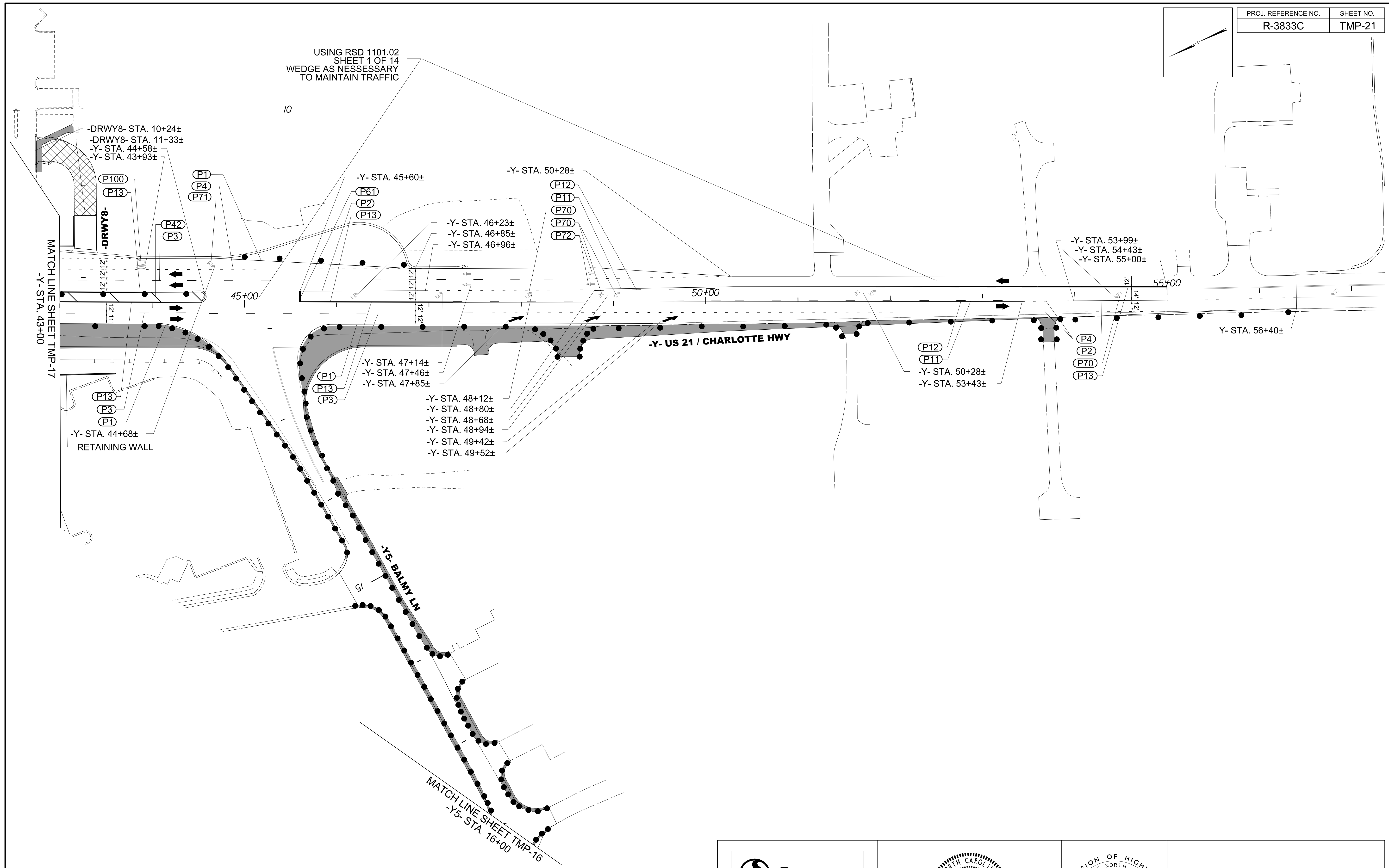
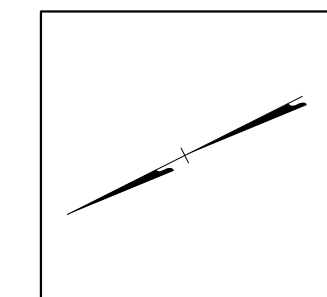

5/1/2023
 U:\Traffic\Transportation Management\Plan\TCP\PLAN SHEETS\IR-3833C-TMP_2\PHASE 2.dgn
 angood

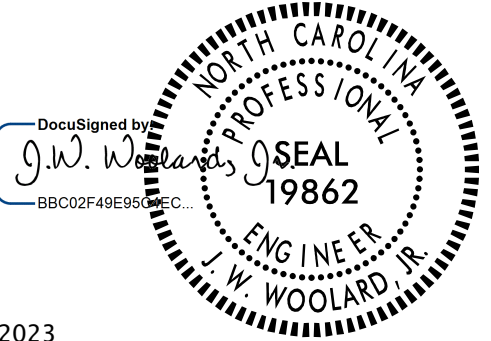
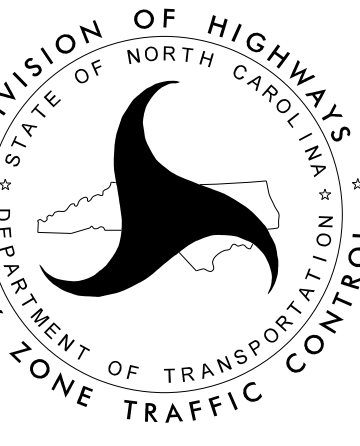
 <p>Stantec Consulting Services Inc. 801 Jones Franklin Road Suite 300 Raleigh, NC 27606 Tel. 919.851.6866 Fax. 919.851.7024 www.stantec.com License No. F-0672</p>	<p>5/1/2023</p>  <p>DOCUMENT NOT CONSIDERED FINAL UNLESS ALL SIGNATURES COMPLETED</p>		<p align="center">-L- BRAWLEY SCHOOL RD PHASE II STEP 2</p>
---	--	---	--

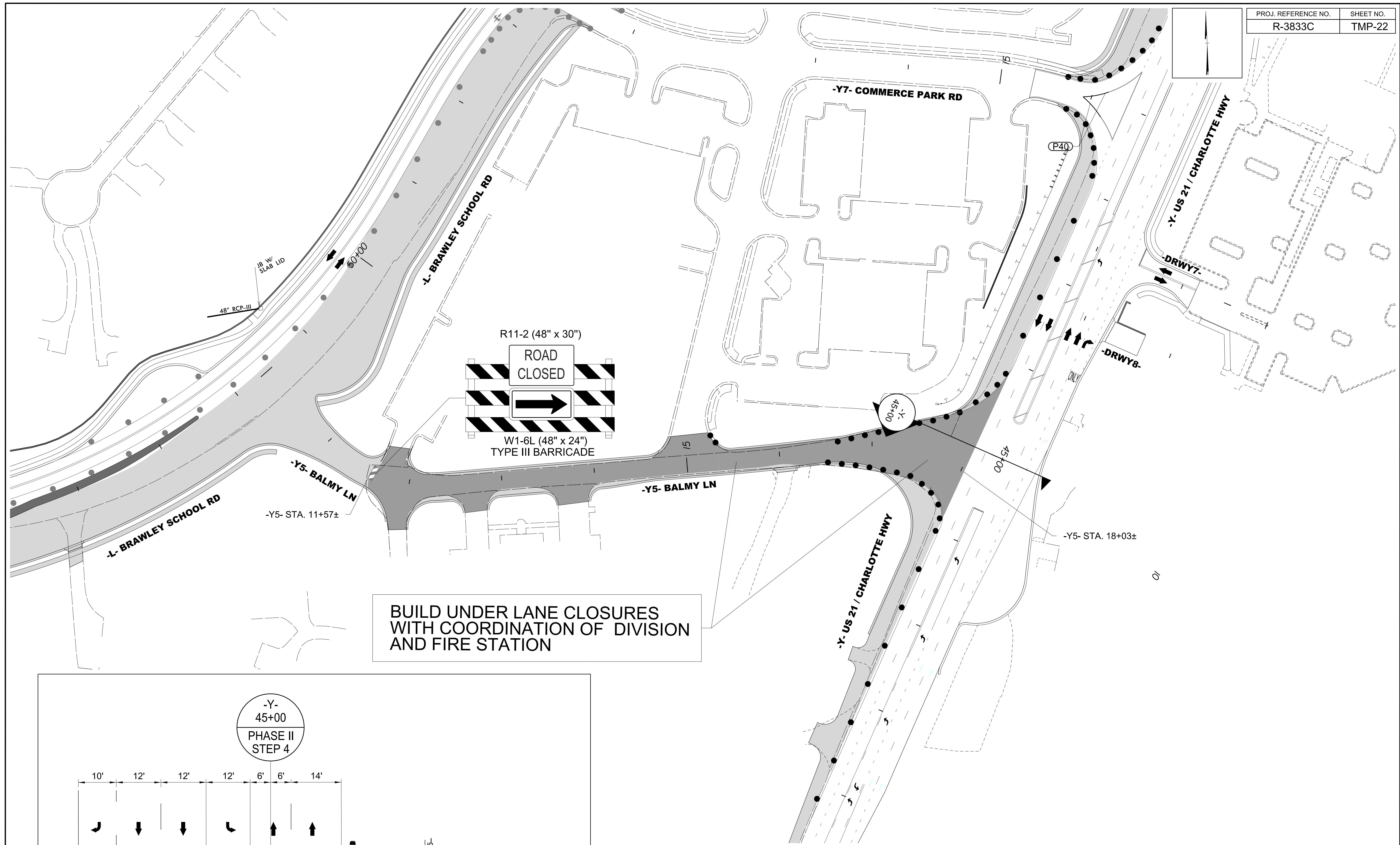

BUILD UNDER LANE CLOSURES
WITH COORDINATION OF DIVISION
AND FIRE STATION

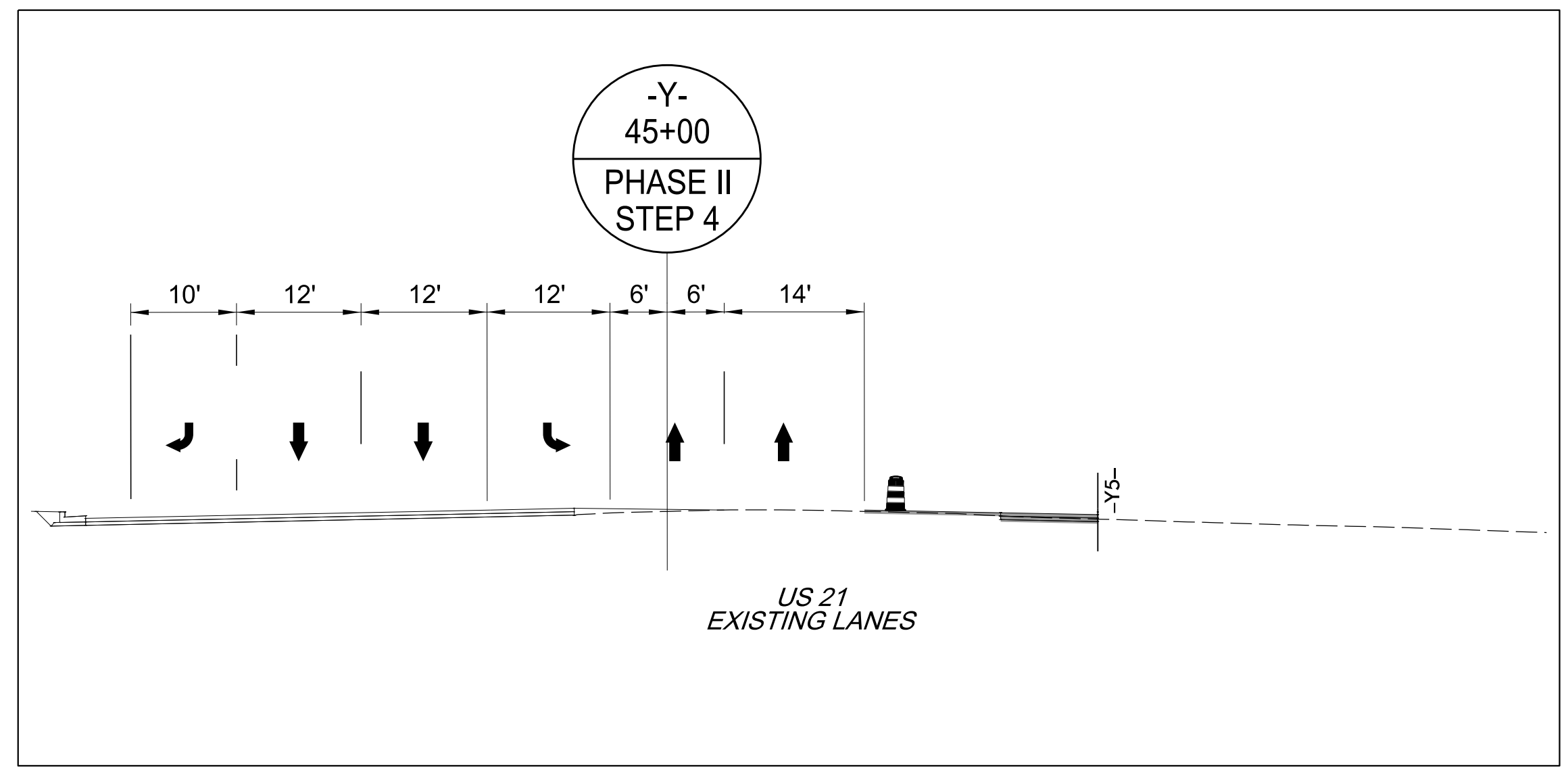

Stantec
 Stantec Consulting Services Inc.
 801 Jones Franklin Road
 Suite 300
 Raleigh, NC 27606
 Tel. 919.851.6866
 Fax. 919.851.7024
 www.stantec.com
 License No. F-0672

5/1/2023
**DOCUMENT NOT CONSIDERED FINAL
 UNLESS ALL SIGNATURES COMPLETED**

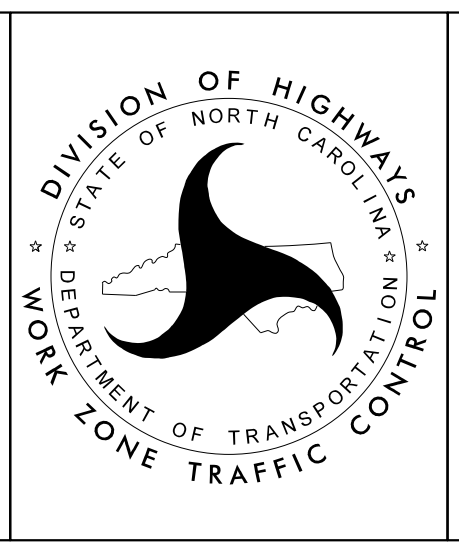

**-L- BRAWLEY SCHOOL RD
 PHASE II
 STEP 4**

5/1/2023
 UsTrafficTransportation Management Plan\TCP\PLAN SHEETS\VR-3833C-TMP_22_PHASE 2_STEP 2.dgn
 angood

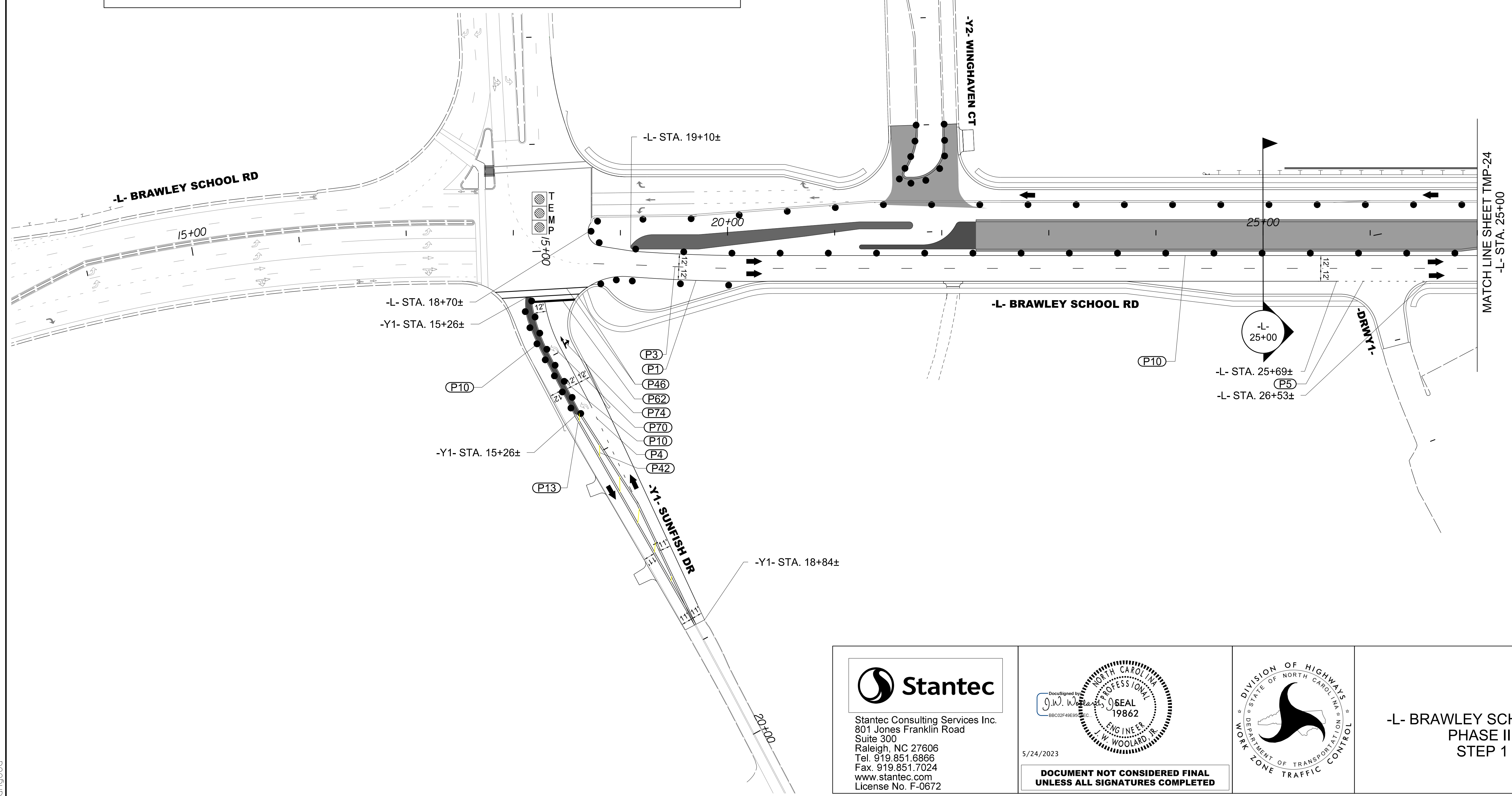
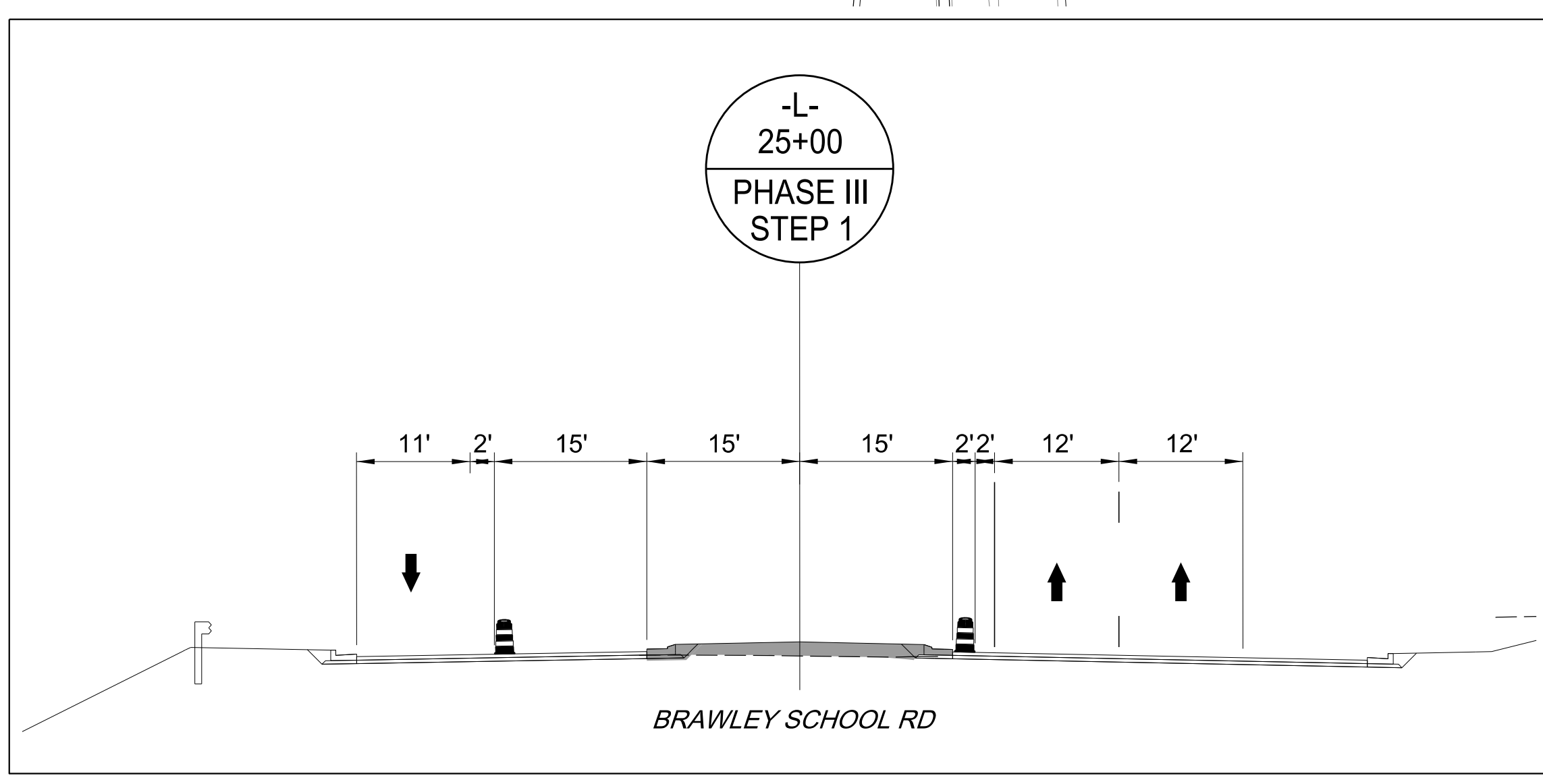
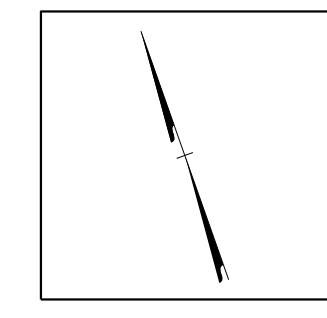

5/24/2023
 U:\Traffic\Transportation Management\Plan\TCP\PLAN SHEETS\IR-3833C-TMP-23_PHASE 3.dgn
 angood

 Stantec Consulting Services Inc.
 801 Jones Franklin Road
 Suite 300
 Raleigh, NC 27606
 Tel. 919.851.6866
 Fax. 919.851.7024
 www.stantec.com
 License No. F-0672

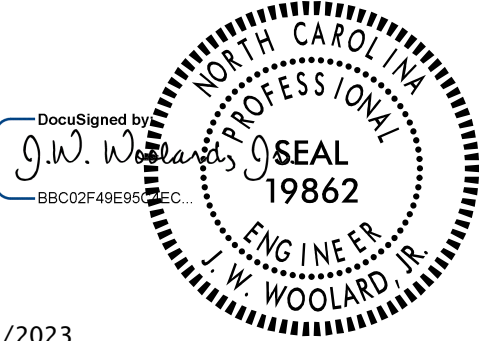
5/24/2023

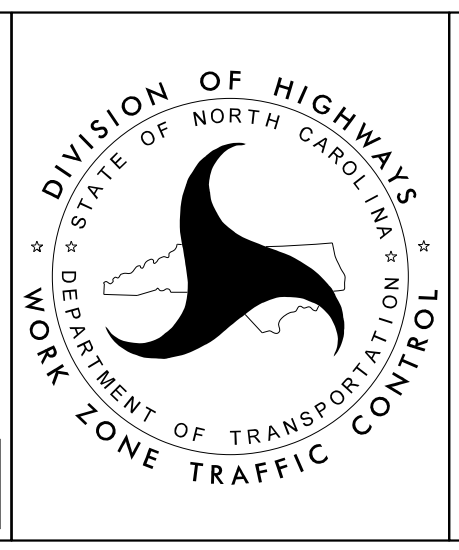
**DOCUMENT NOT CONSIDERED FINAL
 UNLESS ALL SIGNATURES COMPLETED**

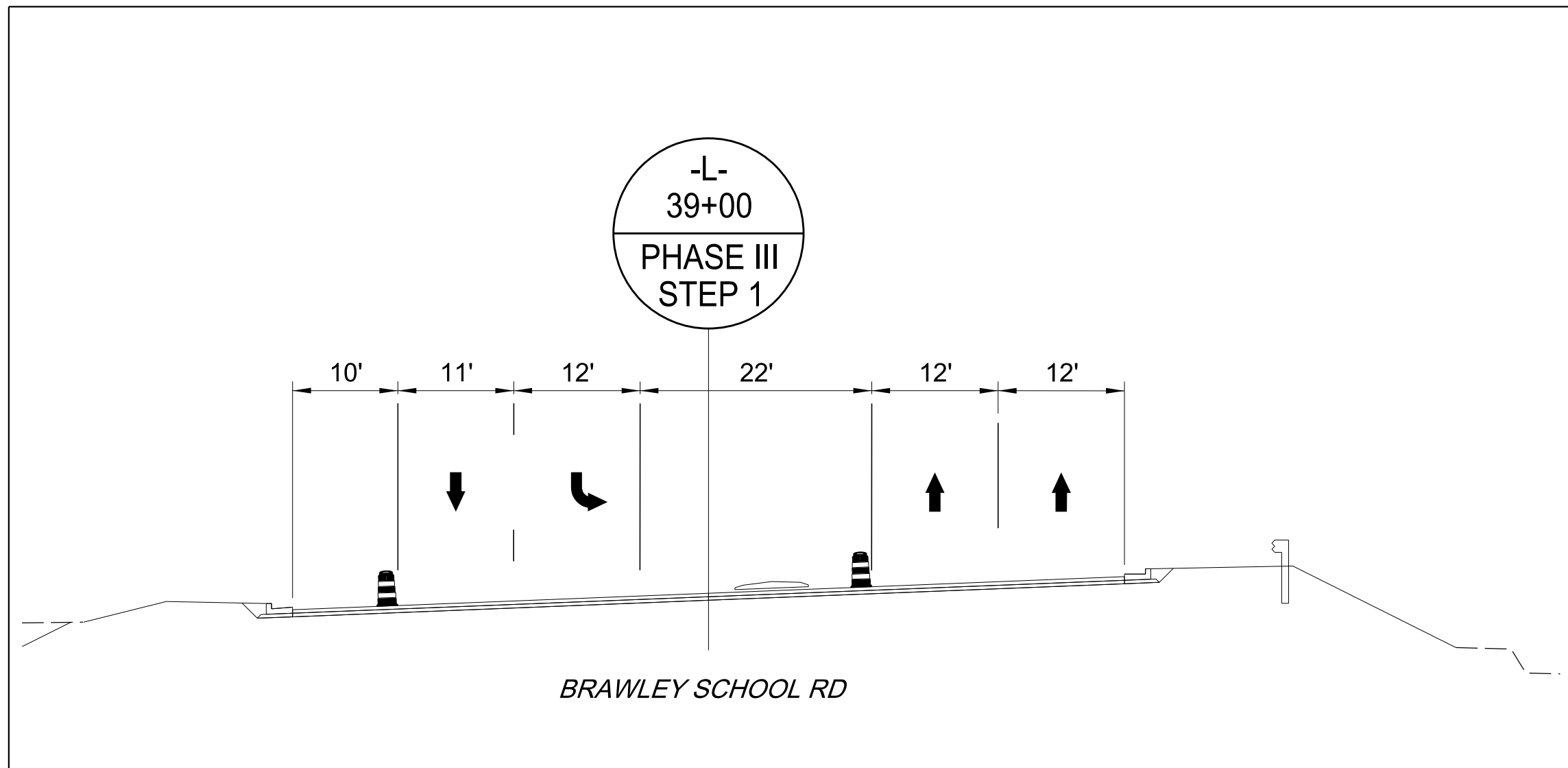
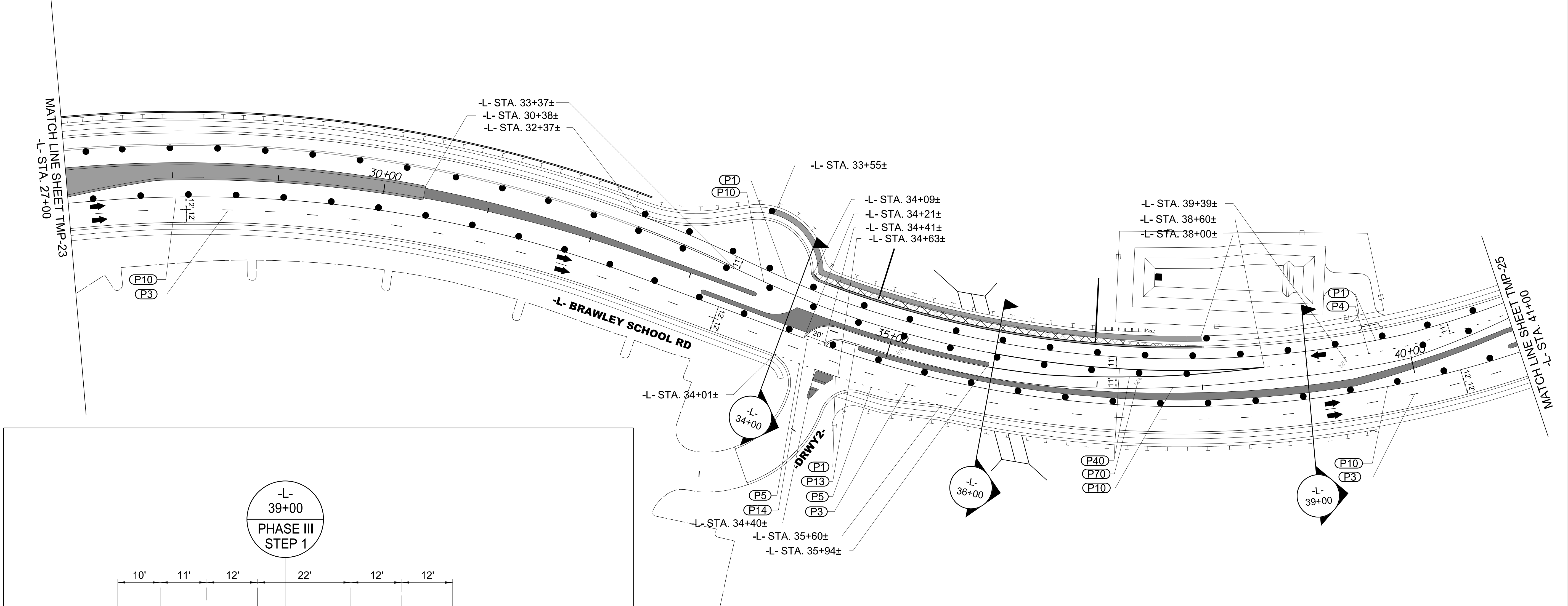
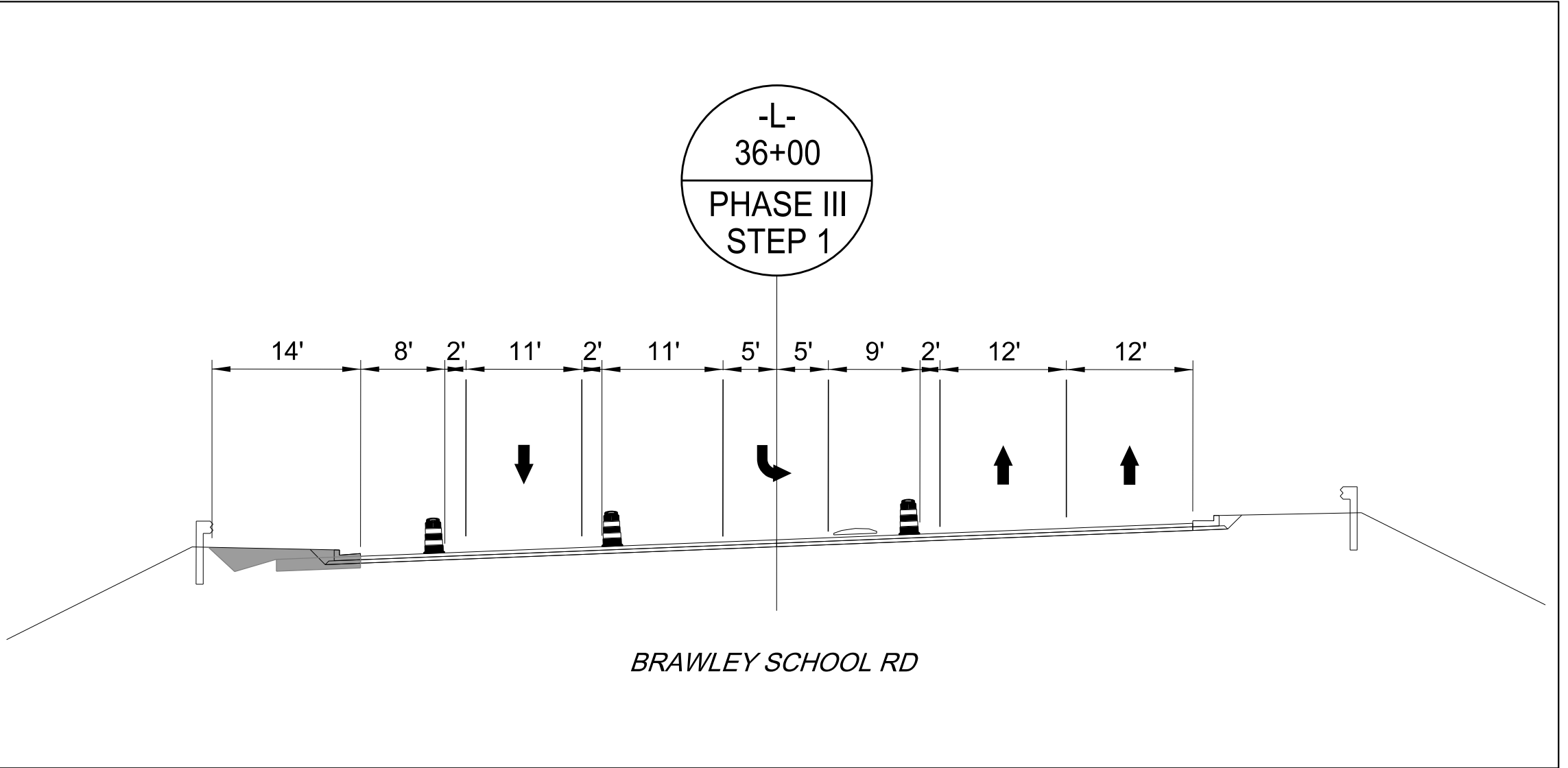
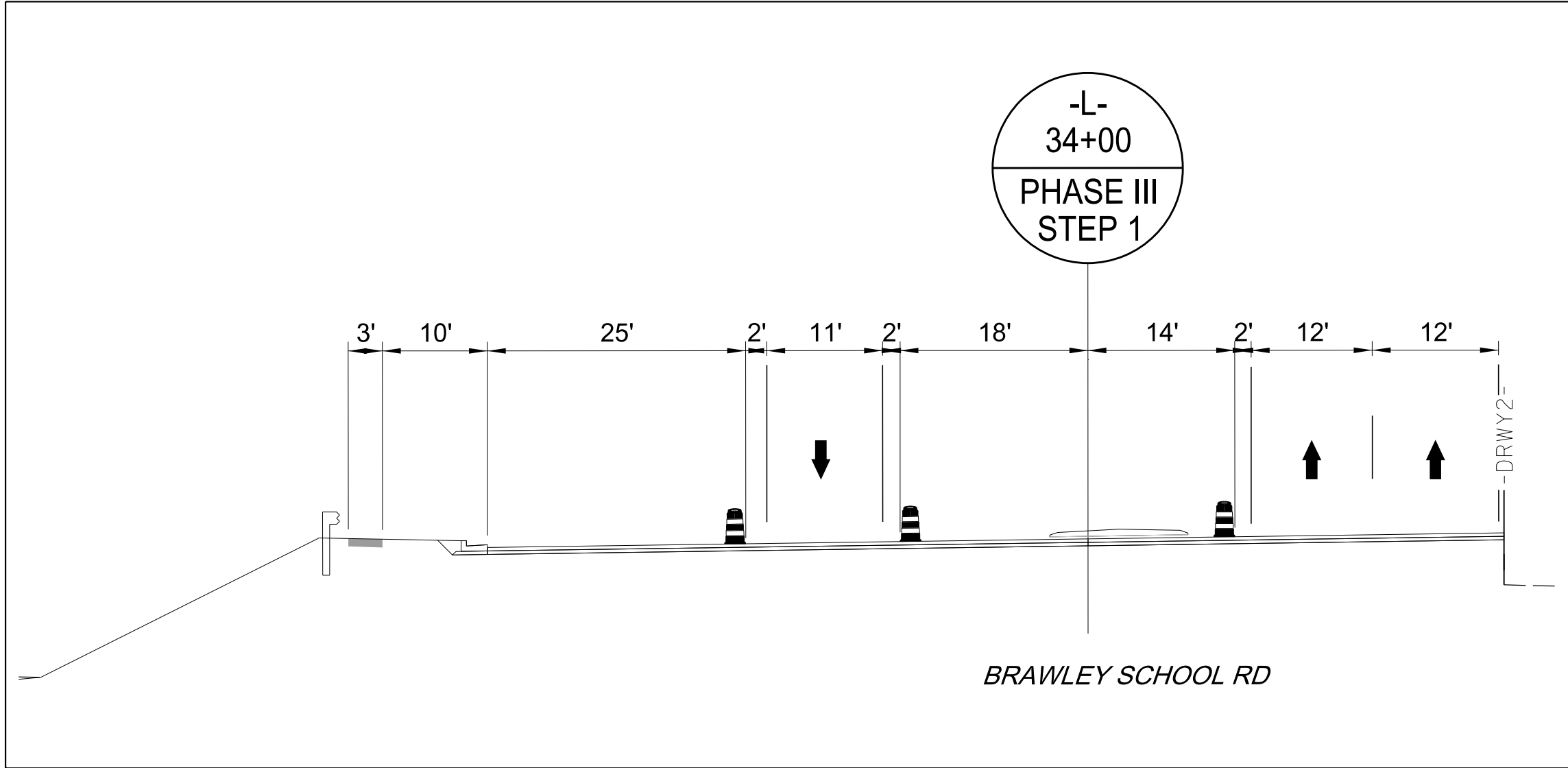
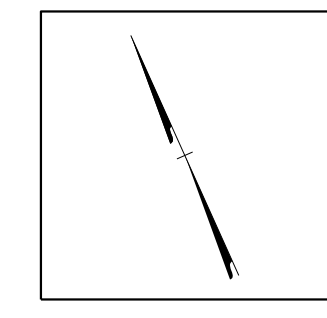

**-L- BRAWLEY SCHOOL RD
 PHASE III
 STEP 1**



5/1/2023
 U:\Traffic\Transportation Management Plan\TCP\PLAN SHEETS\IR-3833C-TMP-24\PHASE 3.dgn
 angood

<p>Stantec Consulting Services Inc. 801 Jones Franklin Road Suite 300 Raleigh, NC 27606 Tel. 919.851.6866 Fax. 919.851.7024 www.stantec.com License No. F-0672</p>	<p>5/1/2023</p> <p>DOCUMENT NOT CONSIDERED FINAL UNLESS ALL SIGNATURES COMPLETED</p>	<p>DIVISION OF HIGHWAYS NORTH CAROLINA DEPARTMENT OF TRANSPORTATION WORK ZONE TRAFFIC CONTROL</p>	<p align="center">-L- BRAWLEY SCHOOL RD PHASE III STEP 1</p>
---	--	--	---

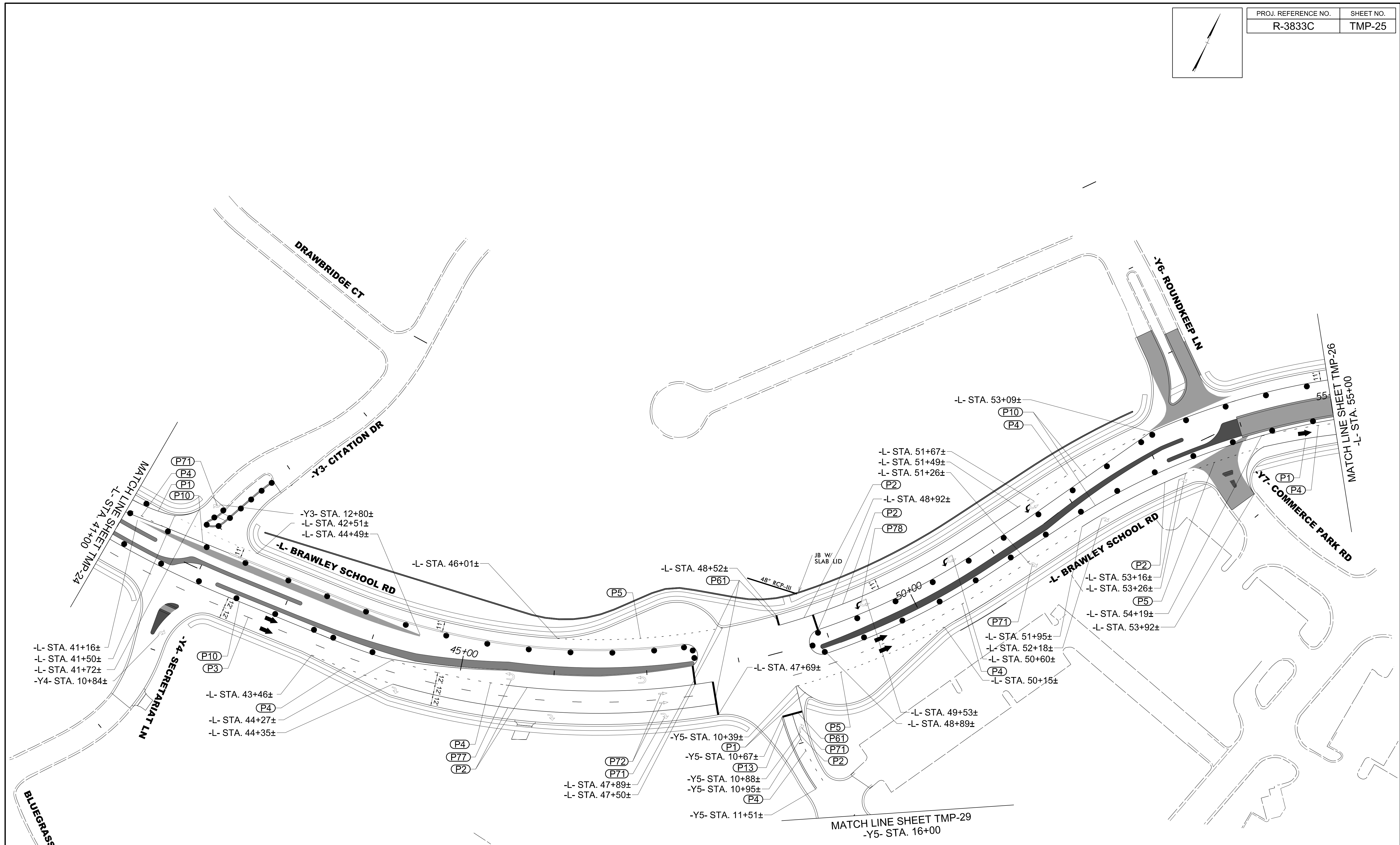
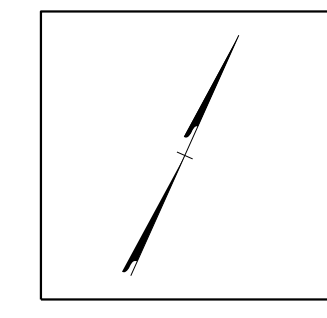

5/1/2023
 U:\Traffic\Transportation Management Plan\TCP\PLAN SHEETS\R-3833C-TMP-25_PHASE 3.dgn
 angood

<p>Stantec Consulting Services Inc. 801 Jones Franklin Road Suite 300 Raleigh, NC 27606 Tel. 919.851.6866 Fax. 919.851.7024 www.stantec.com License No. F-0672</p>	<p>5/1/2023</p> <p>DOCUMENT NOT CONSIDERED FINAL UNLESS ALL SIGNATURES COMPLETED</p>	<p>DIVISION OF HIGHWAYS NORTH CAROLINA DEPARTMENT OF TRANSPORTATION WORK ZONE TRAFFIC CONTROL</p>	<p>-L- BRAWLEY SCHOOL RD PHASE III STEP 1</p>
---	--	--	--

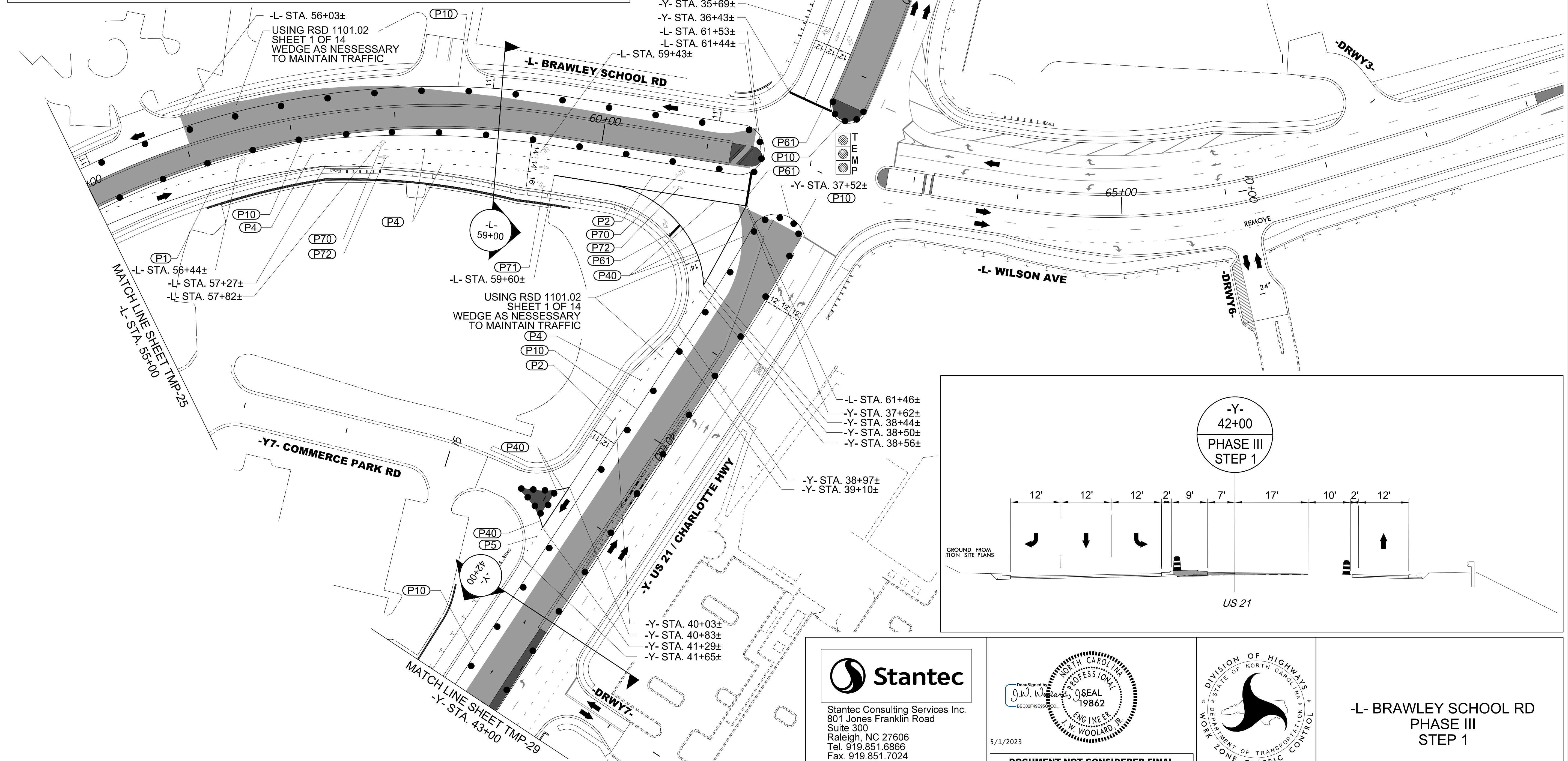
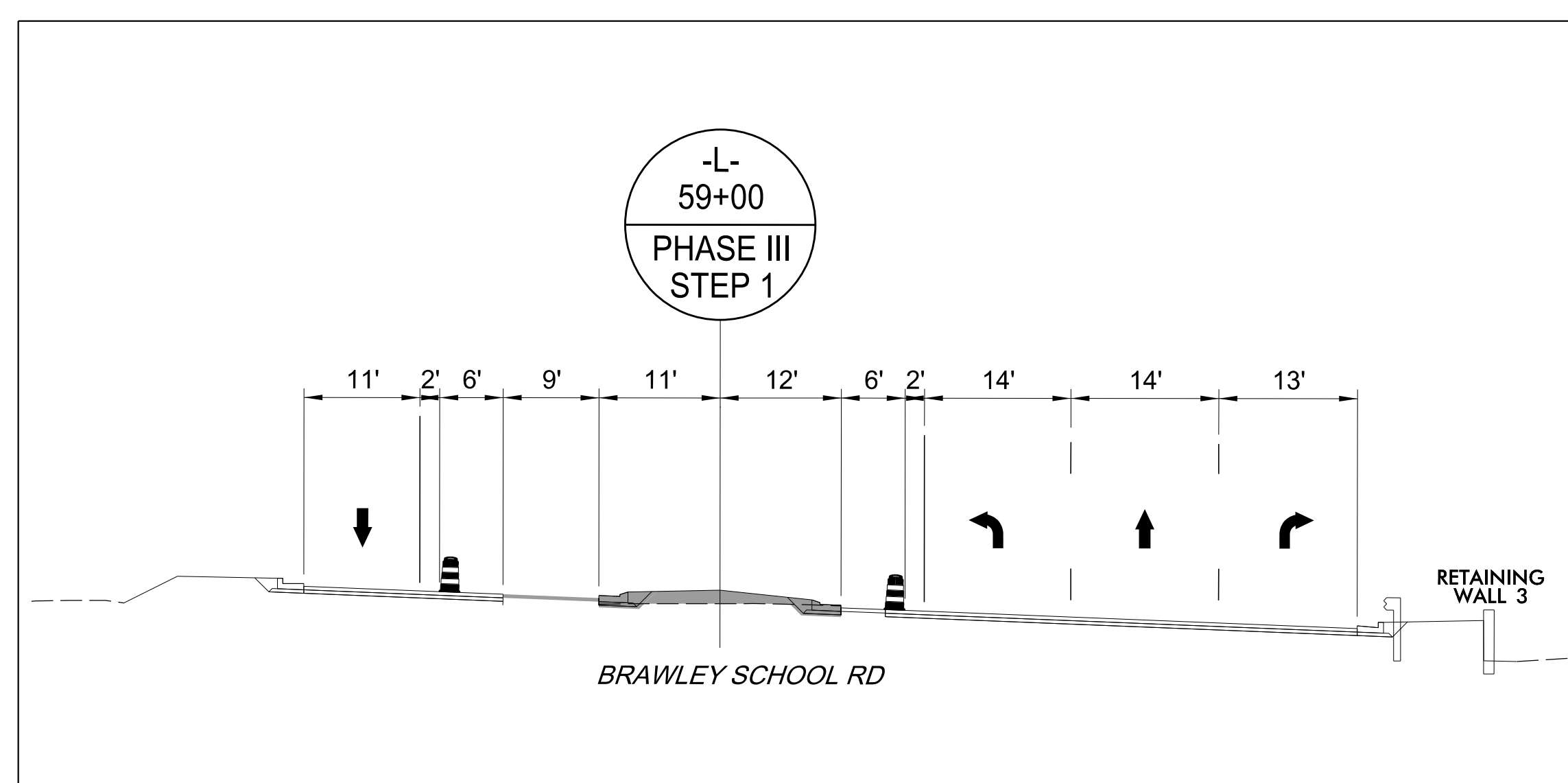
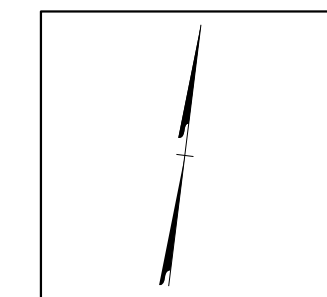

5/1/2023
L:\Traffic\Transportation Management\Plan\TCP\PLAN SHEETS\VR-3833C-TMP-26_PHASE 3.dgn
angood

Stantec
 Stantec Consulting Services Inc.
 801 Jones Franklin Road
 Suite 300
 Raleigh, NC 27606
 Tel. 919.851.6866
 Fax. 919.851.7024
 www.stantec.com
 License No. F-0672

5/1/2023

DOCUMENT NOT CONSIDERED FINAL
UNLESS ALL SIGNATURES COMPLETED

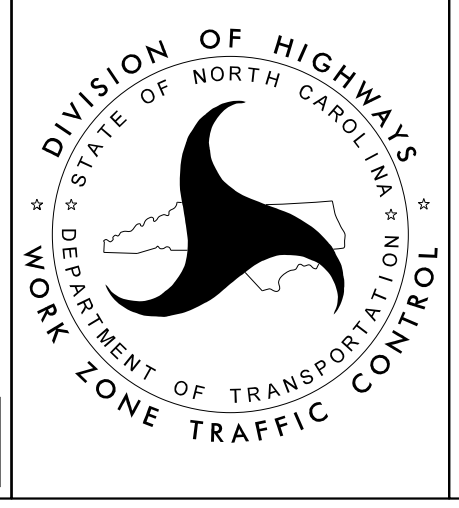

-L- BRAWLEY SCHOOL RD
PHASE III
STEP 1

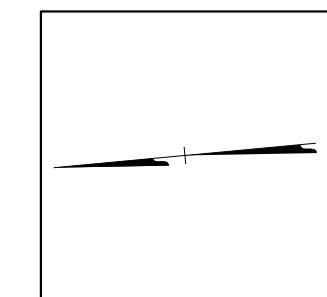

PROJ. REFERENCE NO.	SHEET NO.
R-3833C	TMP-27

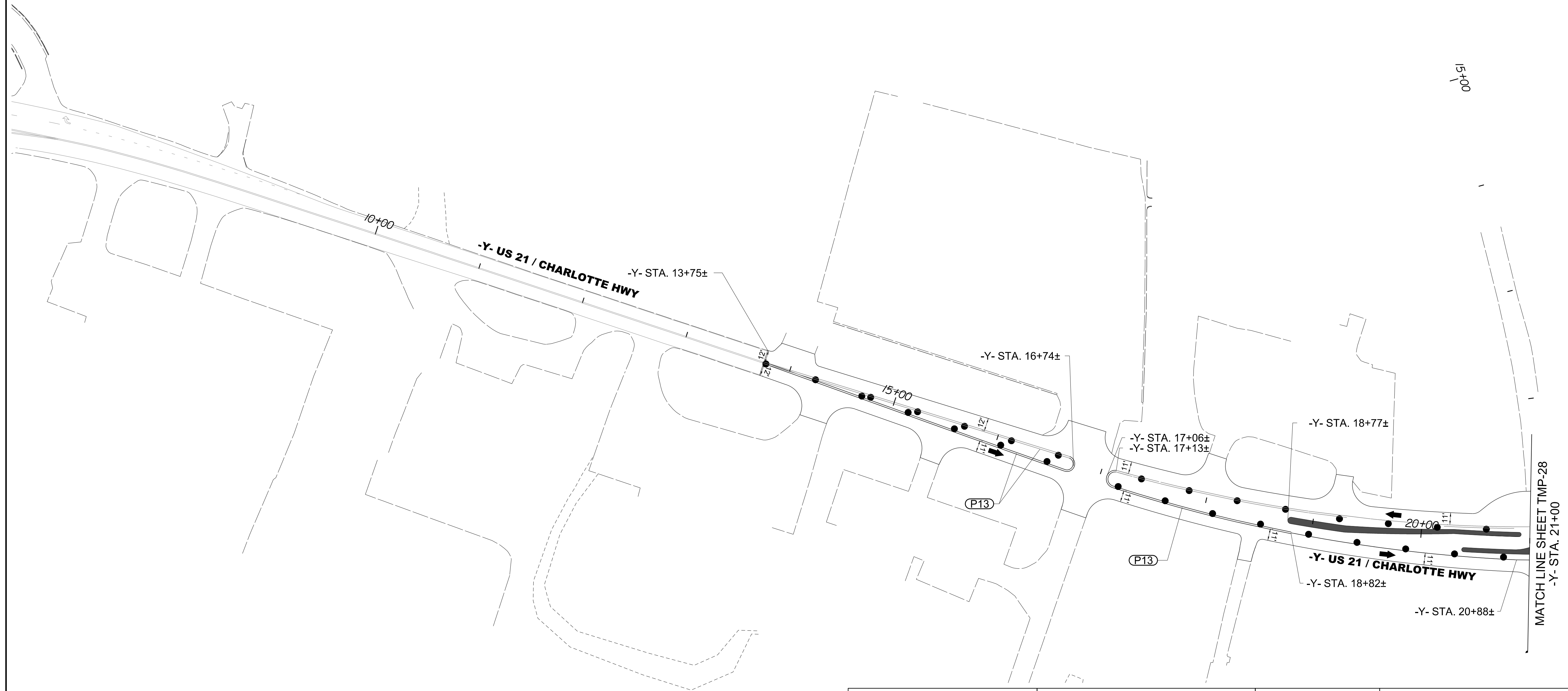

5/1/2023
 U:\Traffic\Transportation Management\Plan\TCP\PLAN SHEETS\R-3833C-TMP-27_PHASE 3.dgn
 angood



 Stantec Consulting Services Inc.
 801 Jones Franklin Road
 Suite 300
 Raleigh, NC 27606
 Tel. 919.851.6866
 Fax. 919.851.7024
 www.stantec.com
 License No. F-0672

5/1/2023

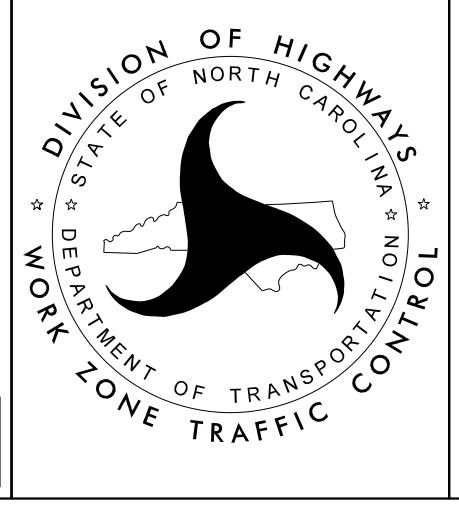
**DOCUMENT NOT CONSIDERED FINAL
 UNLESS ALL SIGNATURES COMPLETED**

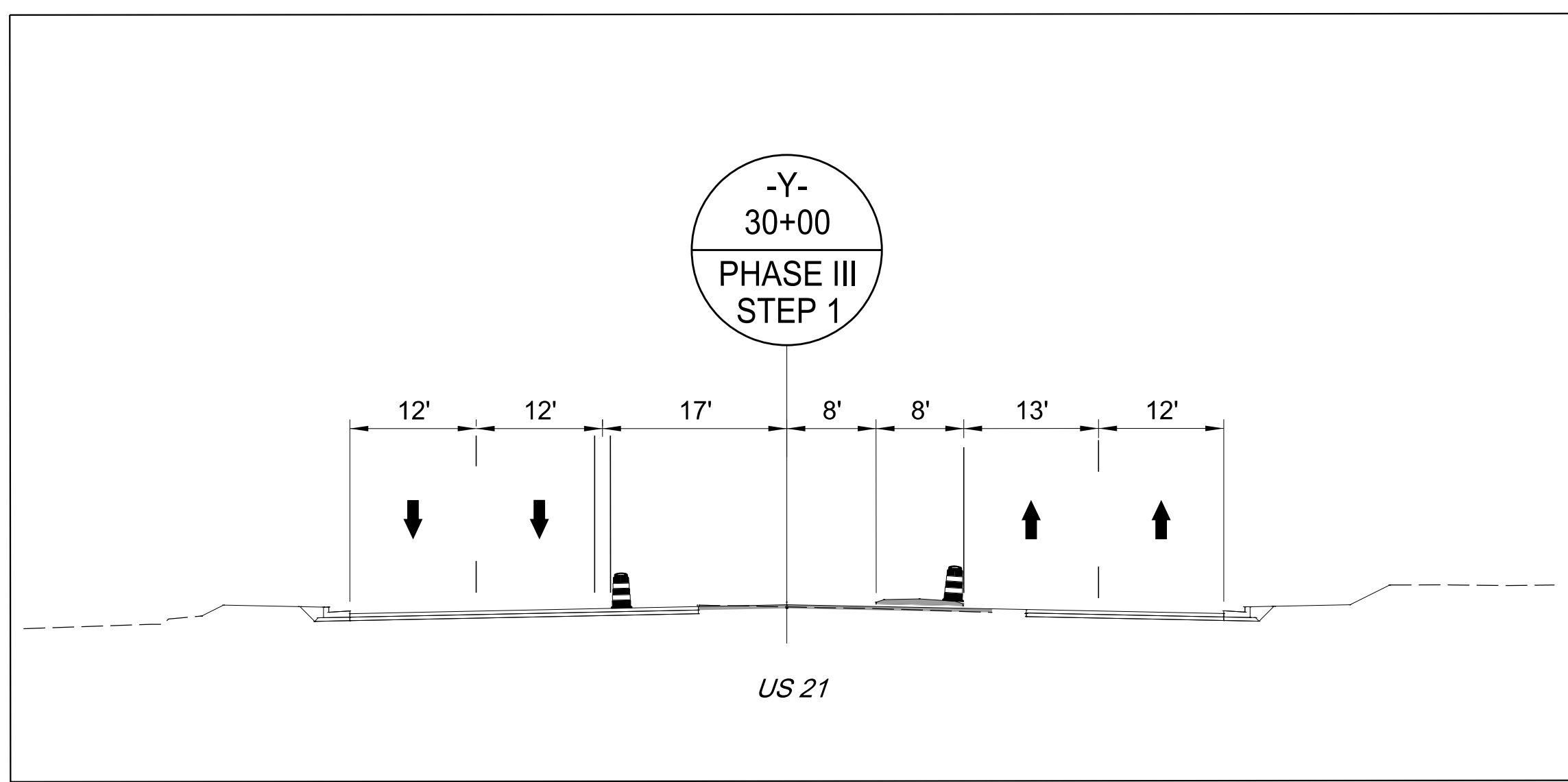
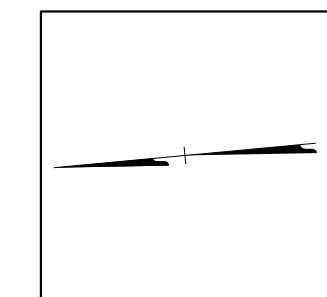

**-L- BRAWLEY SCHOOL RD
 PHASE III
 STEP 1**



15+00

MATCH LINE SHEET TMP-27
-Y- STA. 21+00

DRY DOCK LOOP

-Y- STA. 22+50±

(P10)
(P4)

MARY IDA LN

(P3)
-Y- STA. 25+91±
-Y- STA. 24+75±

(P1)

-Y- STA. 28+49±

-Y- US 21 / CHARLOTTE HWY

(P10)

-Y- 30+00

-Y- STA. 30+75±

(P3)

-Y- US 21 / CHARLOTTE HWY

(P4)

-Y- STA. 32+36±

-DRWY5-

MATCH LINE SHEET TMP-26
-Y- STA. 34+00

CONSTRUCT MEDIAN TURN LANES IN A MANNER SUCH THAT NO CONSECUTIVE AREAS ARE CLOSE TO TRAFFIC, AS DIRECTED BY THE ENGINEER

5/1/2023
L:\Traffic\Transportation Management Plan\TCP\PLAN SHEETS\IR-3833C-TMP-28_PHASE 3.dgn
angood

Stantec Consulting Services Inc.
801 Jones Franklin Road
Suite 300
Raleigh, NC 27606
Tel. 919.851.6866
Fax. 919.851.7024
www.stantec.com
License No. F-0672

DocuSigned by
J.W. Woolard
BBO2F49E83C...

5/1/2023

**DOCUMENT NOT CONSIDERED FINAL
UNLESS ALL SIGNATURES COMPLETED**

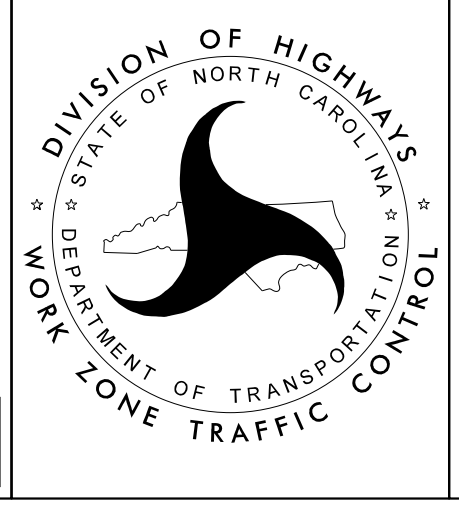

-L- BRAWLEY SCHOOL RD
PHASE III
STEP 1

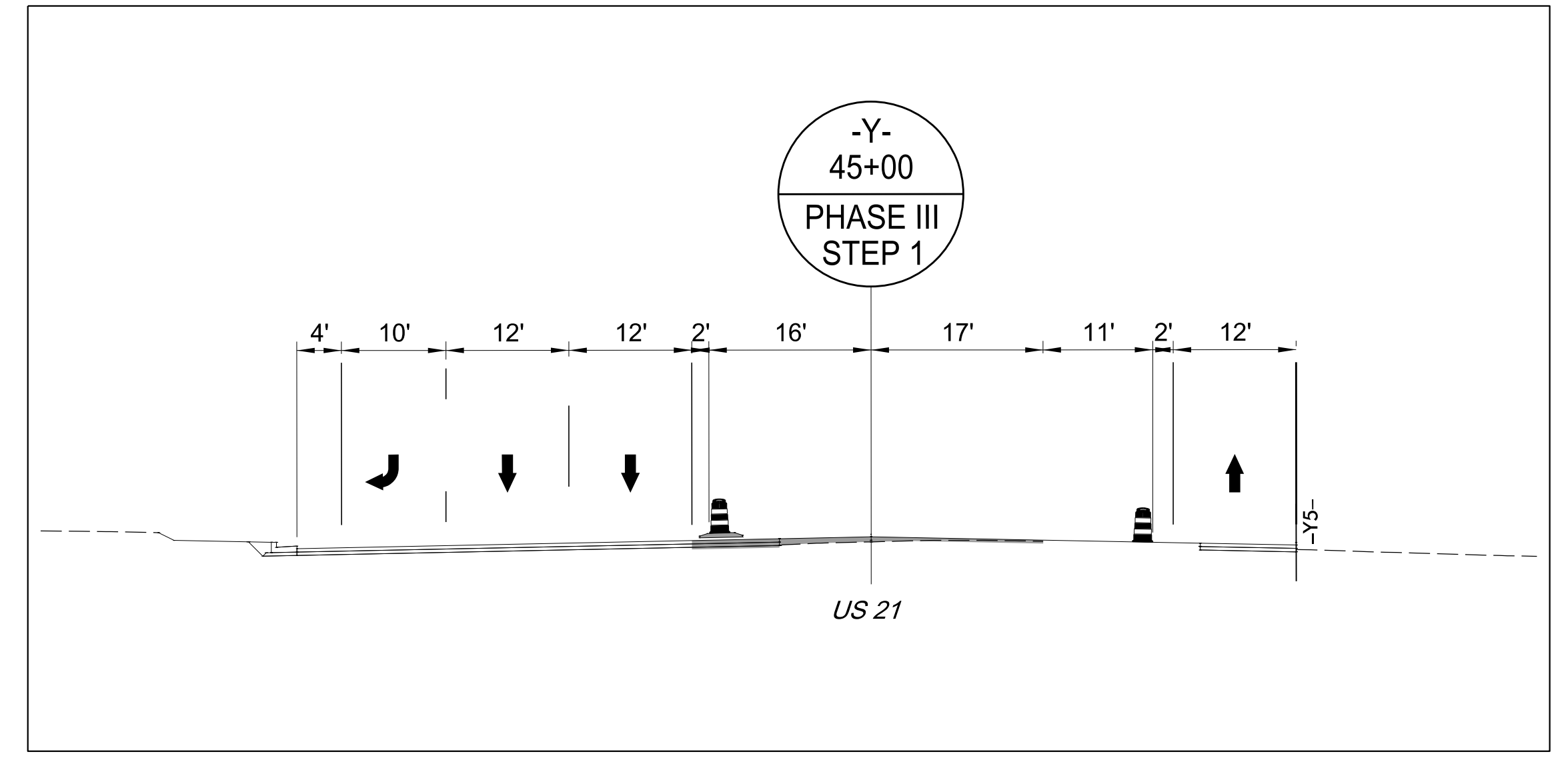
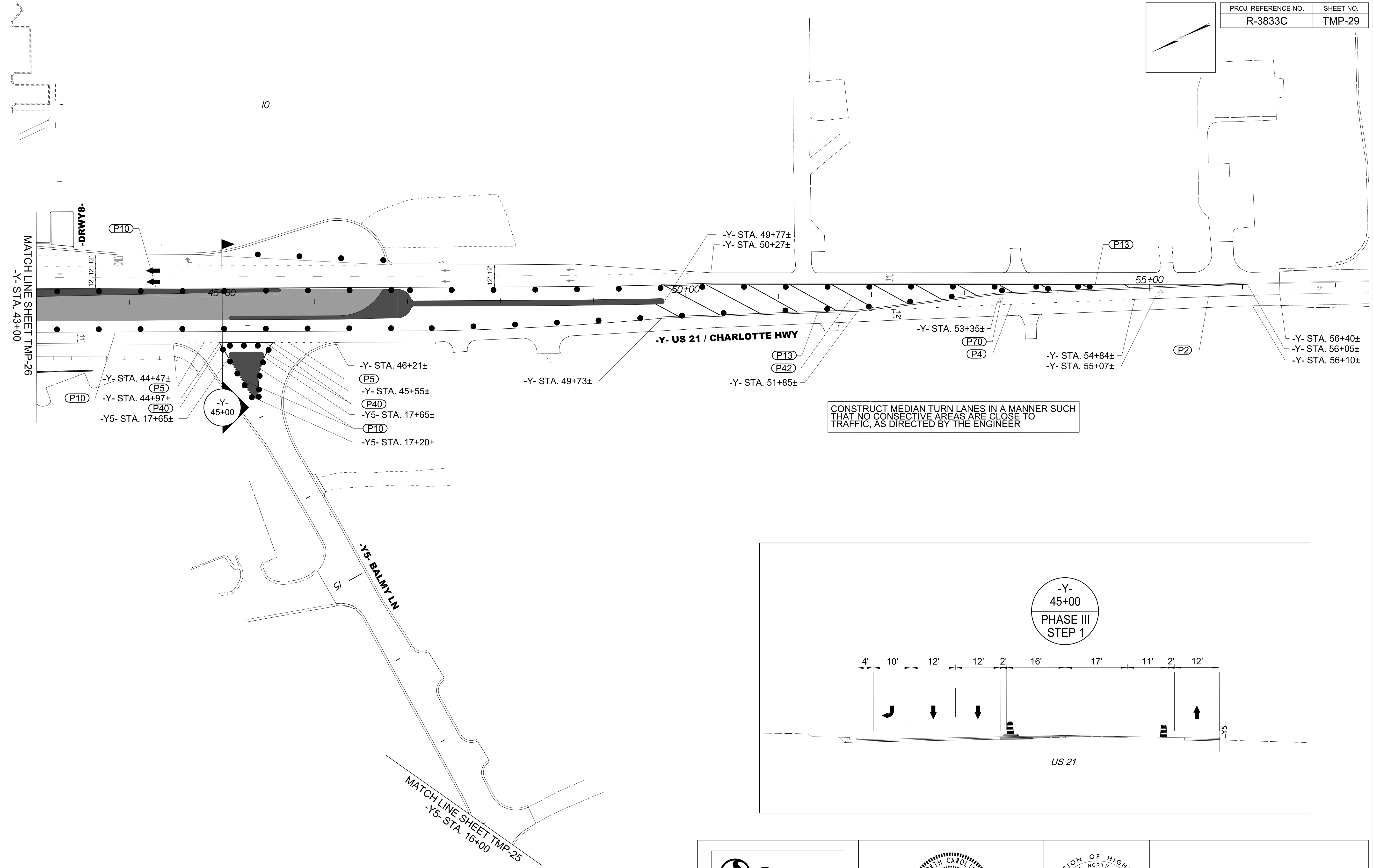

5/1/2023
 U:\Traffic\Transportation Management\Plan\TCP\PLAN SHEETS\IR-3833C-TMP-29_PHASE 3.dgn
 angood

<p>Stantec Consulting Services Inc. 801 Jones Franklin Road Suite 300 Raleigh, NC 27606 Tel. 919.851.6866 Fax. 919.851.7024 www.stantec.com License No. F-0672</p>	<p>DocuSigned by: J.W. Woolard 19862 ENGINEER V. W. WOOLARD, R.</p> <p>5/1/2023</p> <p>DOCUMENT NOT CONSIDERED FINAL UNLESS ALL SIGNATURES COMPLETED</p>	<p>DIVISION OF HIGHWAYS DEPARTMENT OF TRANSPORTATION WORK ZONE TRAFFIC CONTROL</p>	<p>-L- BRAWLEY SCHOOL RD PHASE III STEP 1</p>
--	---	--	--

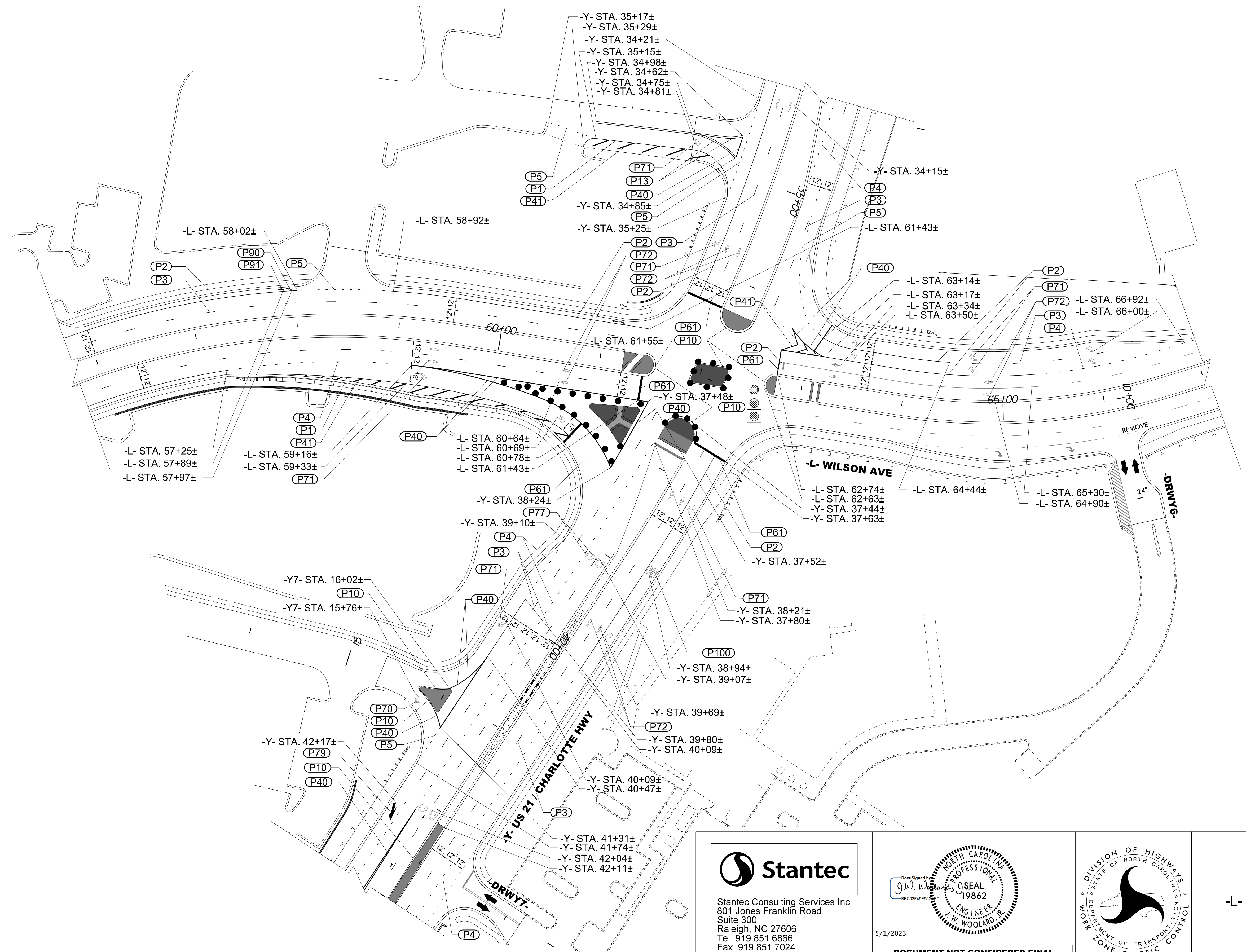
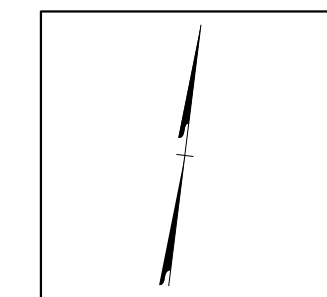

5/1/2023
 U:\Traffic\Transportation Management\Plan\TCP\PLAN SHEETS\IR-3833C-TMP_30_PHASE 3_STEP 2.dgn
 angood

Stantec Consulting Services Inc.
 801 Jones Franklin Road
 Suite 300
 Raleigh, NC 27606
 Tel. 919.851.6866
 Fax. 919.851.7024
 www.stantec.com
 License No. F-0672

5/1/2023
**DOCUMENT NOT CONSIDERED FINAL
 UNLESS ALL SIGNATURES COMPLETED**

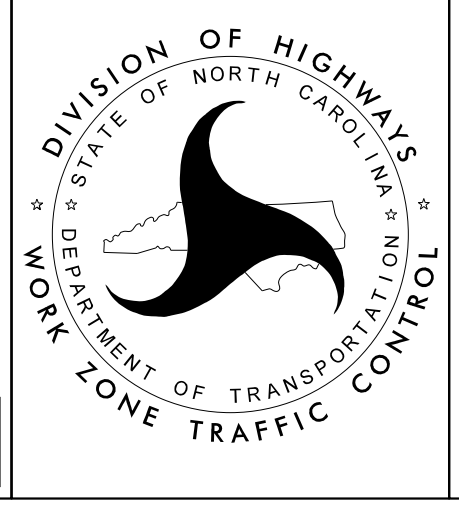

**-L- BRAWLEY SCHOOL RD
 PHASE III
 STEP 2**