

KERNERSVILLE LOOP
AT LINVILLE SPRINGS RD./
PINEY GROVE RD.
SIG. INV. # 09-0365

LEGEND
X = FUSION SPLICE
E = EXISTING SPLICE
C = CAP IN TRAY

COLOR CODE
TIA/EIA 598-A
(1) BLUE (7) RED
(2) ORANGE (8) BLACK
(3) GREEN (9) YELLOW
(4) BROWN (10) VIOLET
(5) SLATE (11) ROSE
(6) WHITE (12) AQUA

CABINET AT INTERSECTION 09-0365

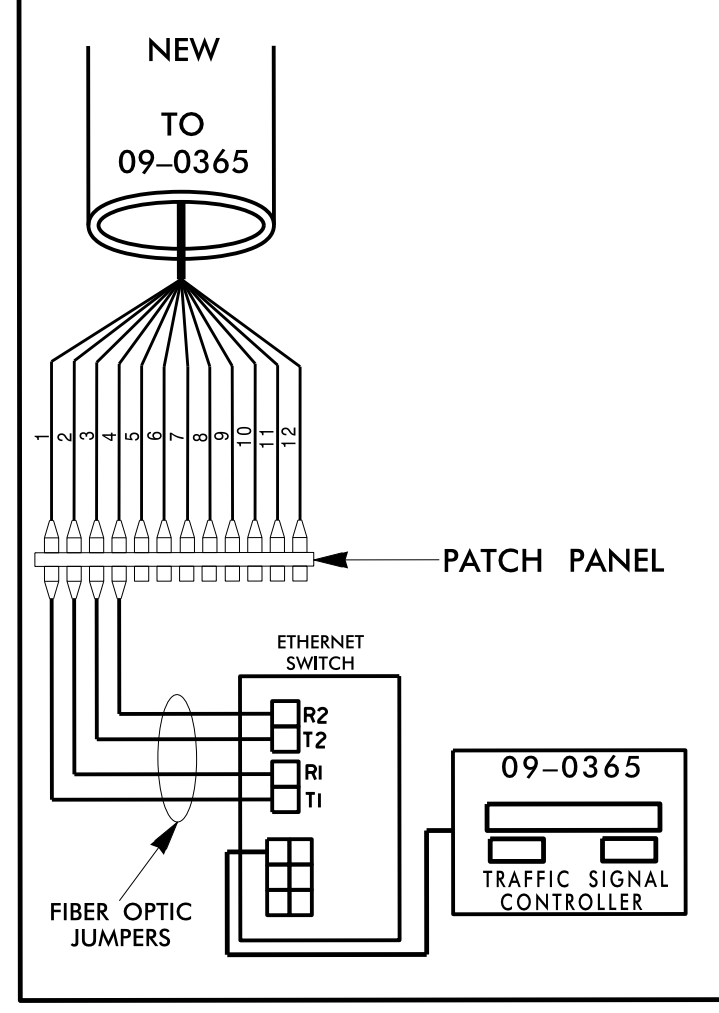

Notes:
Unused fibers left coiled and stored in splice tray.
Unused Buffer Tubes left coiled and stored in splice tray.

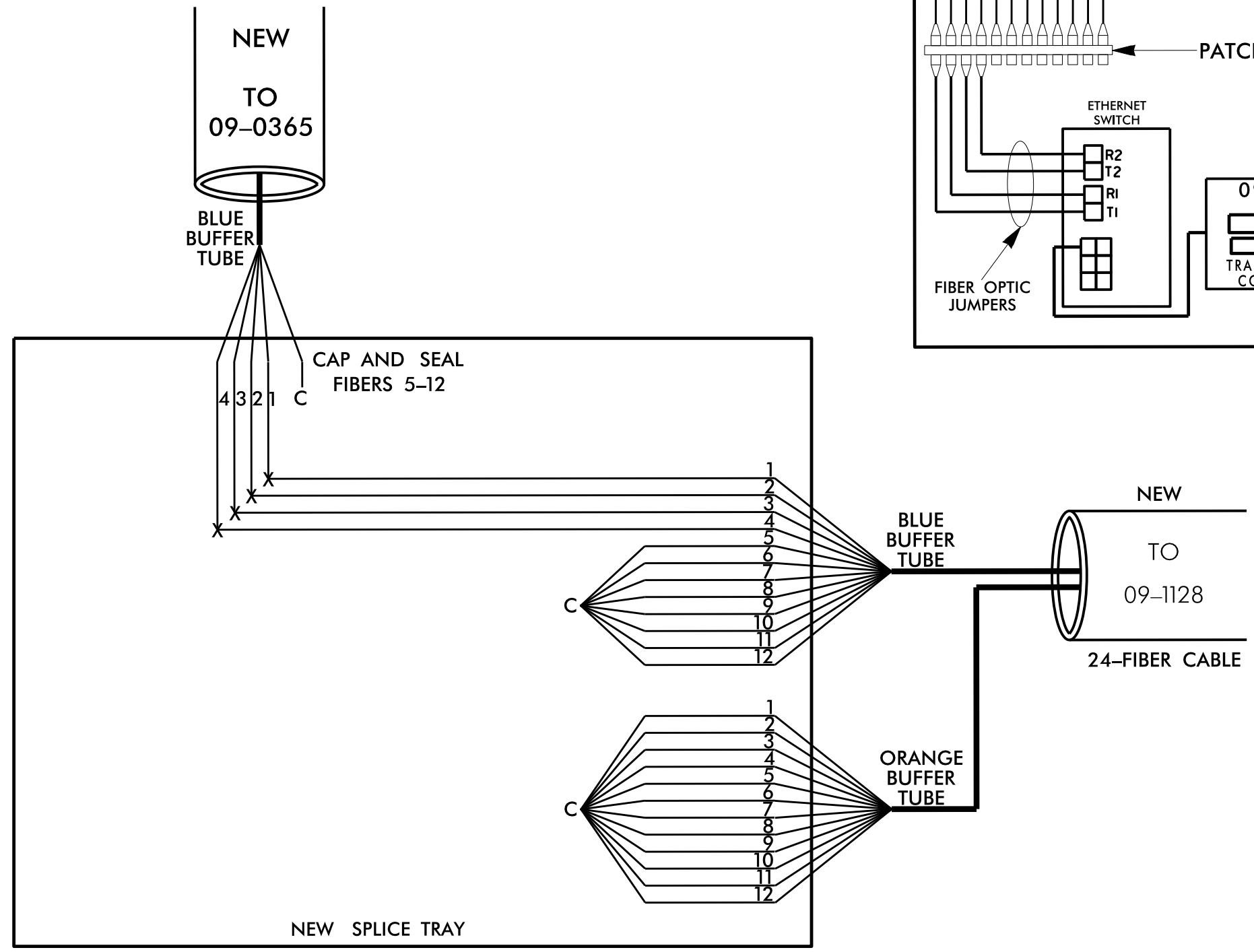

KERNERSVILLE LOOP
AT NC 150 (N. MAIN ST./
MACY GROVE RD.
SIG. INV. # 09-1128

LEGEND
X = FUSION SPLICE
E = EXISTING SPLICE
C = CAP IN TRAY

COLOR CODE
TIA/EIA 598-A
(1) BLUE (7) RED
(2) ORANGE (8) BLACK
(3) GREEN (9) YELLOW
(4) BROWN (10) VIOLET
(5) SLATE (11) ROSE
(6) WHITE (12) AQUA

CABINET AT INTERSECTION 09-1128

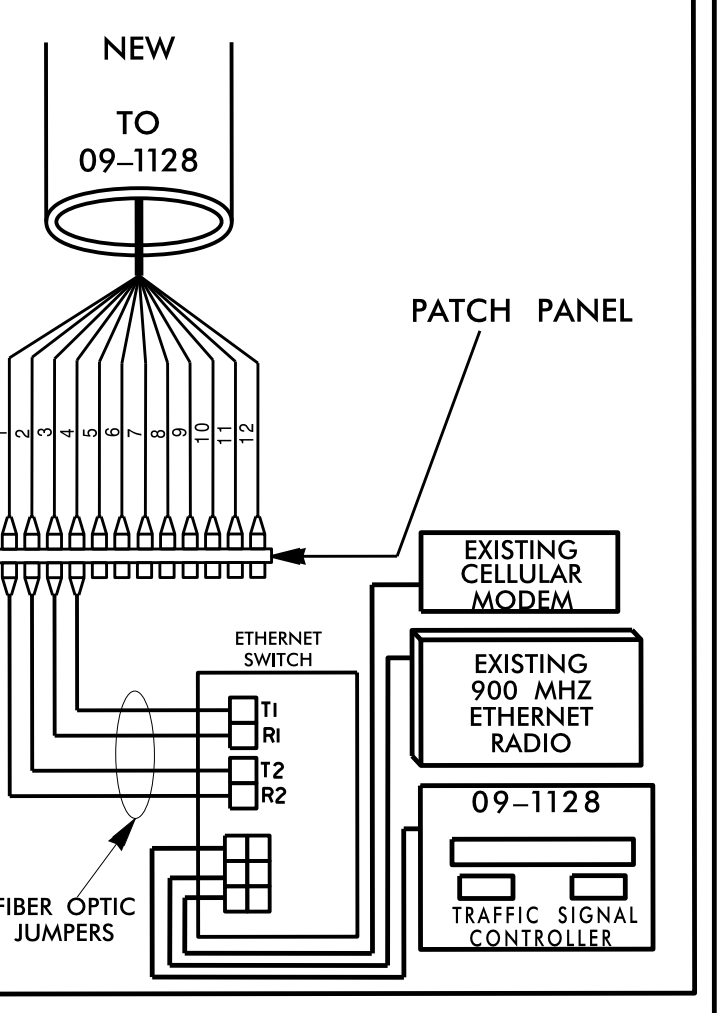

Notes:
Unused fibers left coiled and stored in splice tray.
Unused Buffer Tubes left coiled and stored in splice tray.

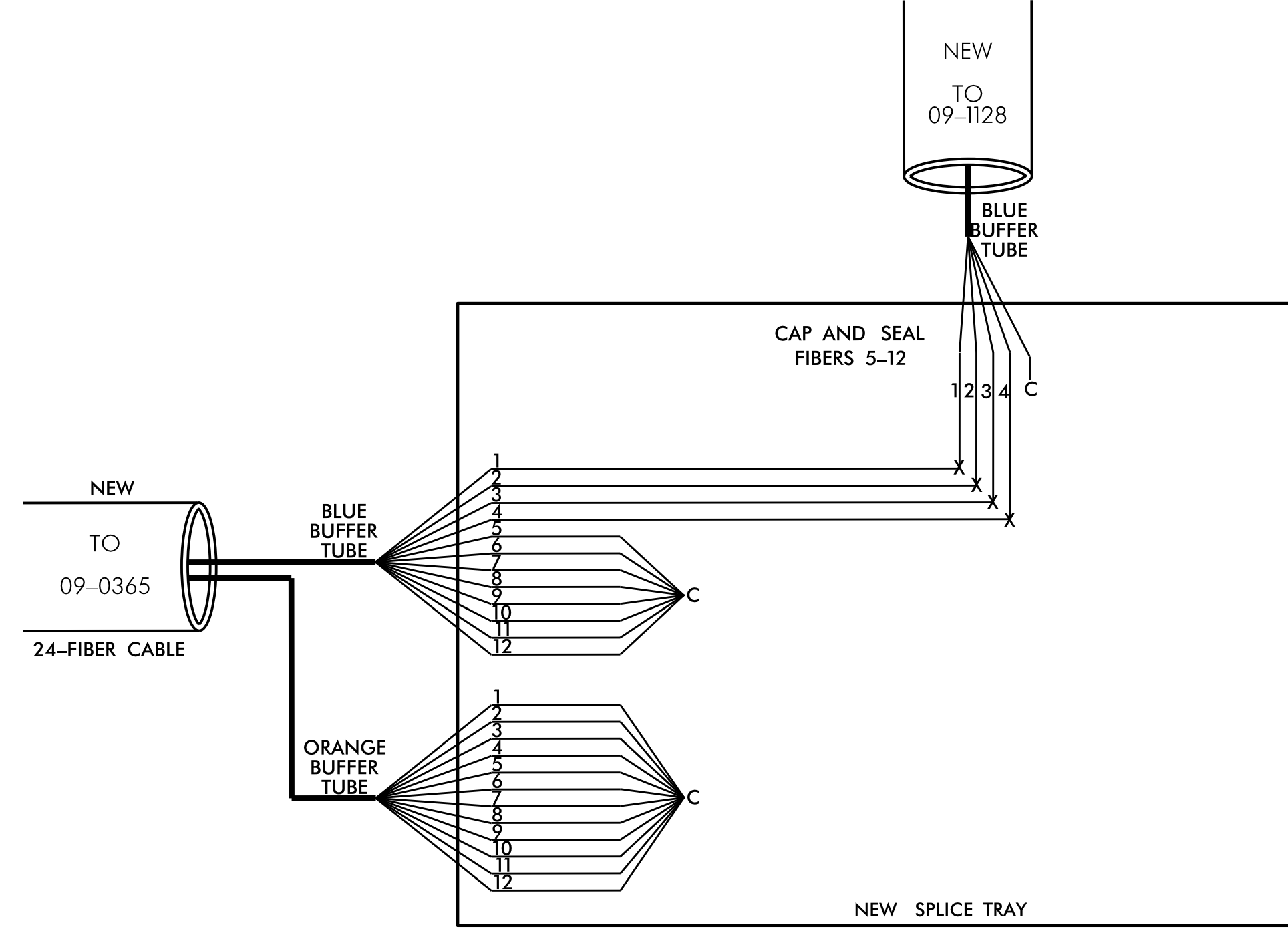

GENERAL NOTES:

- FIVE (5) DAYS PRIOR TO BEGINNING WORK ON THE SIGNAL SYSTEM, CONTACT THE DIVISION TRAFFIC ENGINEER AT (336)747-7800 TO ARRANGE FOR THE DIVISION TO PROGRAM THE NEW FIELD ETHERNET SWITCHES WITH THE NECESSARY NETWORK CONFIGURATION DATA, INCLUDING BUT NOT LIMITED TO: THE PROJECT IP ADDRESS, DEFAULT GATEWAY, SUBNET MASK AND VLAN ID INFORMATION. NOTIFY THE DIVISION TRAFFIC ENGINEER AFTER ALL WORK IS PERFORMED TO ENSURE THAT ALL FIBER CIRCUITS ARE FUNCTIONING PROPERLY. WORK IS NOT COMPLETE UNTIL THE SIGNAL SYSTEM IS OPERATIONAL AND COMMUNICATING WITH THE CENTRAL SYSTEM.
- ETHERNET SWITCH TERMINATION CONFIGURATIONS ARE GENERIC. CONTRACTOR IS RESPONSIBLE FOR DETERMINING \ ENSURING PROPER TERMINATIONS.
- INCLUDE ON THE COVER OF EACH SPLICE TRAY THE FOLLOWING: REFERENCE SECTION 1731 "FIBER OPTIC SPLICE ENCLOSURE"
 - SPLICE LOCATION
 - DATE
 - COMPANY NAME
 - NAME OF INDIVIDUAL PERFORMING THE SPLICING

PRIOR TO INSTALLING THE COVER ON THE SPLICE TRAY TAKE A DIGITAL PHOTOGRAPH SHOWING THE SPLICE TRAY AND INFORMATION SHOWN ABOVE (1-4) AND SUBMIT PHOTOGRAPH ALONG WITH OTDR TEST RESULTS.

DOCUMENT NOT CONSIDERED FINAL UNLESS ALL SIGNATURES COMPLETED

<p>250 N. Greenfield Pkwy., Garner, NC 27529</p>	<p>D09-28 KERNERSVILLE SPLICE DETAILS</p>							
	<p>DIVISION 09 FORSYTH KERNERSVILLE</p> <p>PLAN DATE: JULY 2023 REVIEWED BY: <i>Gregory B.</i></p> <p>PREPARED BY: H.T. BERGGREN, EI</p>	<p>REVISIONS</p> <table border="1"> <tr> <th>NO.</th> <th>INIT.</th> <th>DATE</th> </tr> <tr> <td> </td> <td> </td> <td> </td> </tr> </table>		NO.	INIT.	DATE		
NO.	INIT.	DATE						