

18 CHANNEL CONFLICT MONITOR PROGRAMMING DETAIL

(remove jumpers and set switches as shown)

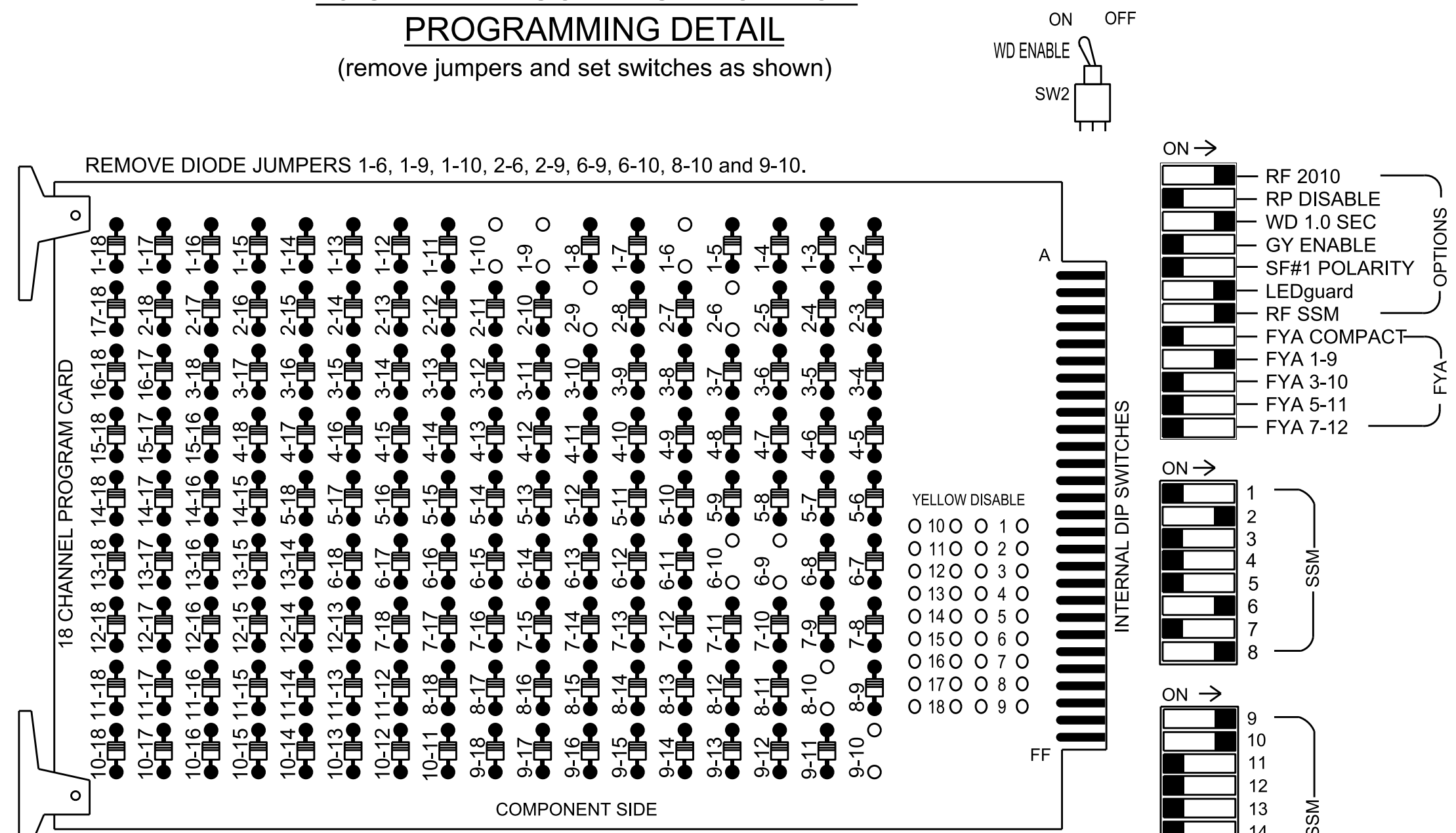

NOTES:

- Card is provided with all diode jumpers in place. Removal of any jumper allows its channels to run concurrently.
- Ensure jumpers SEL2-SEL5 and SEL9 are present on the monitor board.
- Ensure that the Red Enable is active at all times during normal operation.
- Connect serial cable from conflict monitor to comm. port 1 of 2070 controller. Ensure conflict monitor communicates with 2070.

NOTES

- To prevent "flash-conflict" problems, insert red flash program blocks for all unused vehicle load switches in the output file. The installer shall verify that signal heads flash in accordance with the signal plan.
- Program controller to start up in phase 2 Green No Walk and 6 Green No Walk.
- If this signal will be managed by an ATMS software, enable controller and detector logging for all detectors used at this location.
- The cabinet and controller are part of the (NC 150 at Macy Grove - Road and County Line Road CLS) Signal System #: D09-28_Kernersville.

EQUIPMENT INFORMATION

Controller.....2070LX
 Cabinet.....332 w/ Aux
 Software.....Q-Free MAXTIME
 Cabinet Mount.....Base
 Output File Positions.....18 With Aux. Output File
 Load Switches Used.....S1, S2, S8, S11, S12, AUX S1, AUX S2
 Phases Used.....1, 2, 6, 8
 Overlap "1".....*
 Overlap "2".....*
 Overlap "3".....NOT USED
 Overlap "4".....NOT USED

*See overlap programming detail on sheet 2

SIGNAL HEAD HOOK-UP CHART

LOAD SWITCH NO.	S1	S2	S3	S4	S5	S6	S7	S8	S9	S10	S11	S12	AUX S1	AUX S2	AUX S3	AUX S4	AUX S5	AUX S6
GMU CHANNEL NO.	1	2	13	3	4	14	5	6	15	7	8	16	9	10	17	11	12	18
PHASE	1	2	2 PED	3	4	4 PED	5	6	6 PED	7	8	8 PED	OL1	OL2	SPARE	OL3	OL4	SPARE
SIGNAL HEAD NO.	11*	21,22	NU	NU	NU	NU	NU	61,62	NU	NU	22	81,83	NU	11*	82	NU	NU	NU
RED		128						134										A124
YELLOW	*	129						135										
GREEN		130						136										
RED ARROW												107		A121				
YELLOW ARROW														A122	A125			
FLASHING YELLOW ARROW											108	108		A123				
GREEN ARROW	127										109	109						A126

NU = Not Used

* Denotes install load resistor. See load resistor installation detail this sheet.

*See pictorial of head wiring in detail this sheet.

INPUT FILE POSITION LAYOUT

(front view)

FILE	1	2	3	4	5	6	7	8	9	10	11	12	13	14
U	∅ 1	∅ 1	∅ 2	∅ S	∅ S	∅ S	∅ S	∅ S	∅ S	∅ S	∅ S	∅ S	∅ S	FS
L	1A	1A	2A	ST	ST	ST	ST	ST	ST	ST	ST	ST	ST	DC ISOLATOR
U	NOT USED	∅ 1	NOT USED	∅ 6	∅ 6	∅ 8	∅ 8	∅ 8	∅ 8	∅ 8	∅ 8	∅ 8	∅ 8	DC ISOLATOR
L		1B		6A	6A	8A	8A	8A	8A	8A	8A	8A	8A	

EX. : 1A, 2A, ETC. = LOOP NO.'S

FS = FLASH SENSE
 ST = STOP TIME

INPUT FILE CONNECTION & PROGRAMMING CHART

LOOP NO.	LOOP TERMINAL	INPUT FILE POS.	PIN NO.	INPUT POINT	DETECTOR NO.	CALL PHASE	DELAY TIME	EXTEND TIME	EXTEND	ADDED INITIAL	CALL	DELAY DURING GREEN
1A	TB2-1,2	I1U	56	18	1	1	15		X		X	
1B	TB2-5,6	I2U	39	-	29	6	3		X		X	X
1C	TB2-7,8	I2L	43	5	3	1	15		X		X	
2A	TB2-9,10	I3U	63	29	4	2			X	X	X	
6A	TB3-5,6	J2U	40	2	16	6			X	X	X	
8A	TB5-9,10	J6U	42	4	22	8	3		X	X	X	

INPUT FILE POSITION LEGEND: J2L

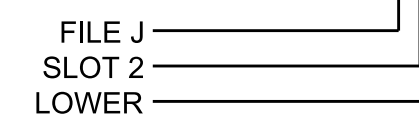

FYA SIGNAL WIRING DETAIL

(wire signal heads as shown)

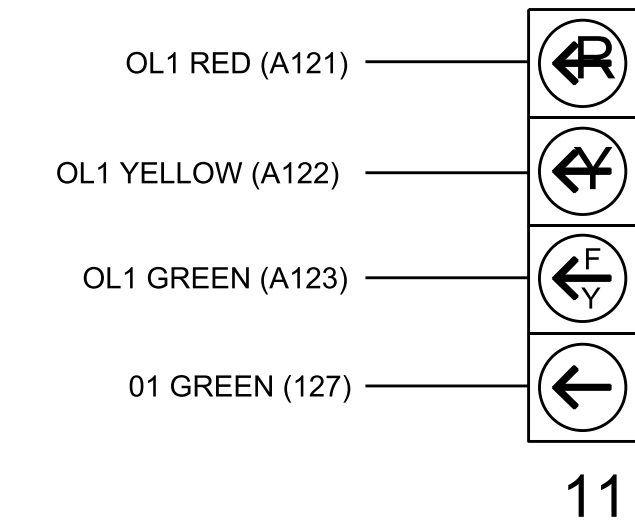

LOAD RESISTOR INSTALLATION DETAIL

(install resistor as shown)

ACCEPTABLE VALUES	
Value (ohms)	Wattage
1.5K - 1.9K	25W (min)
2.0K - 3.0K	10W (min)

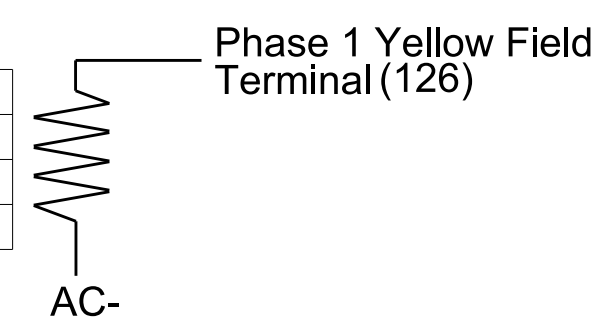

Electrical Detail - Sheet 1 of 2

Electrical and Programming Details For:

Prepared in the Offices of:

750 N. Greenfield Pkwy, Garner, NC 27529

NC 150 (N. Main Street) at SR 2037 (County Line Road)

Division 09 Forsyth County Kernersville

PLAN DATE: July 2023 REVIEWED BY:

PREPARED BY: James Peterson REVIEWED BY:

REVISIONS: INIT. DATE

DocuSigned by: Ryan W. Haugl 08/14/2023

SEAL: RYAN W. HAUGL, ENGINEER, SEAL 036833

SIG. INVENTORY NO. 09-1129

DOCUMENT NOT CONSIDERED FINAL UNLESS ALL SIGNATURES COMPLETED