

HINDE ENGINEERING
 License No. C-2639
 10815 Sikes Place, Suite 210 Charlotte, NC 28277

**DOCUMENT NOT CONSIDERED FINAL
 UNLESS ALL SIGNATURES COMPLETED**

PROJECT REFERENCE NO. C-5621	SHEET NO. UC-3A
DESIGNED BY: JKC	
DRAWN BY: JNA	
CHECKED BY: JKC	
APPROVED BY: CLS	
REVISED:	
NORTH CAROLINA DEPARTMENT OF TRANSPORTATION UTILITIES ENGINEERING SEC. PHONE: (919) 707-6690 FAX: (919) 250-4151 UTILITY CONSTRUCTION PLANS ONLY	

UTILITY CONSTRUCTION

LIST OF STANDARD DETAILS

WATER:

- AA PRECAST CONCRETE METER BOX - 0.75-INCH DOMESTIC WATER SERVICE
- BB PRECAST CONCRETE METER BOX 1-INCH DOMESTIC AND IRRIGATION WATER SERVICE
- DD DEAD END THRUST - WALL BLOCKING WITH 2-INCH BLOW-OFF 6 TO 12-INCH MAINS
- FF CAST IRON VALVE BOX 12-INCH AND SMALLER VALVES
- GG VALVE BOX ADJUSTMENT FOR PAVEMENT RESURFACING
- HH VALVE BOX ASSEMBLY INSTALLATION 12-INCH AND SMALLER VALVES
- J MULTIPLE WATER SERVICES - SCHEMATIC
- K-1 3-4THS AND 1-INCH DOMESTIC WATER SERVICE CONNECTION PART ONE
- K-2 3-4THS AND 1-INCH DOMESTIC WATER SERVICE CONNECTION PART TWO
- M 1.5 INCH DOMESTIC WATER SERVICE CONNECTION
- MM VALVE BOX CONCRETE GRADE RINGS AND FOOTINGS
- N 6-INCH FMCT WATER METER AND VAULT SERVICE CONNECTION
- NN 2-INCH BLOW-OFF ASSEMBLY 2 TO 12-INCH MAINS
- OO PLASTIC WATER METER BOX AND LID - 0.75-INCH DOMESTIC WATER SERVICE
- PP WATER METER BOX - PLASTIC LID - 0.75 AND 1-INCH DOMESTIC WATER SERVICES
- SS TYPE 6 20.5-INCH MANHOLE COVER - USE WITH 16-INCH AND LARGER VALVES
- TT TYPE F 20.5-INCH MANHOLE FRAME 7-INCH TALL
- TW1-3 WATER TRACER DETAILS
- V STEEL DOUBLE LEAF ACCESS DOOR 5 FT X 5 FT PEDESTRIAN LOADING
- VV FIRE HYDRANT PAINT COLOR SCHEMES - CMUD-CFD STANDARDS - PUBLIC AND PRIVATE HYDRANTS

GRAVITY SANITARY SEWER:

- A TYPE 1 24-INCH MANHOLE COVER VENTED
- B TYPE 2 24-INCH MANHOLE COVER SOLID
- F TYPE A 24-INCH MANHOLE FRAME 7 AND HALF - INCH TALL
- G TYPE B 24-INCH MANHOLE FRAME 4-INCH TALL
- TS1 TRACER WIRE - GRAVITY SEWER
- TS2 TRACER WIRE - GRAVITY SEWER DETAILS
- TS4 TRACER WIRE - FORCE MAIN SEWER
- TS5 TRACER WIRE - SEWER MAIN - SPLICE

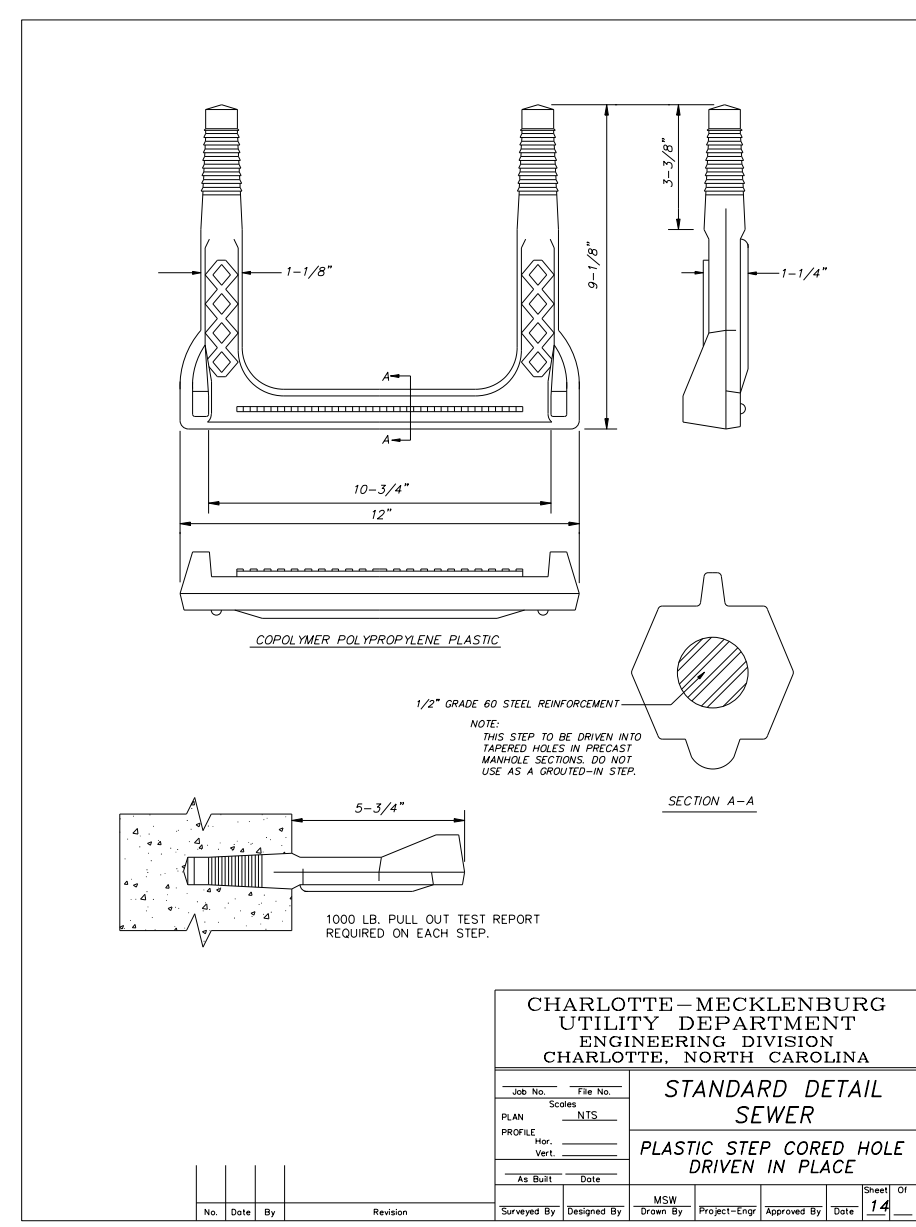
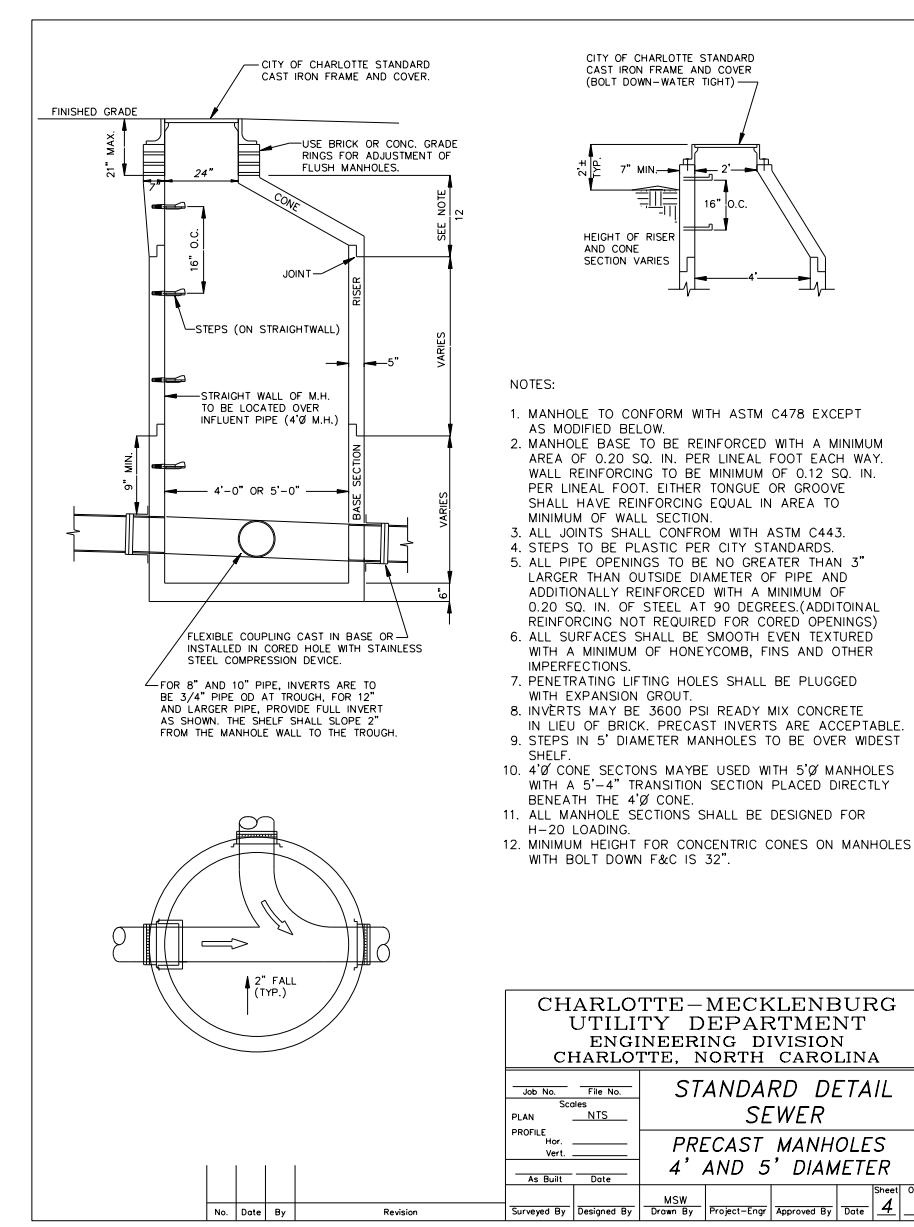
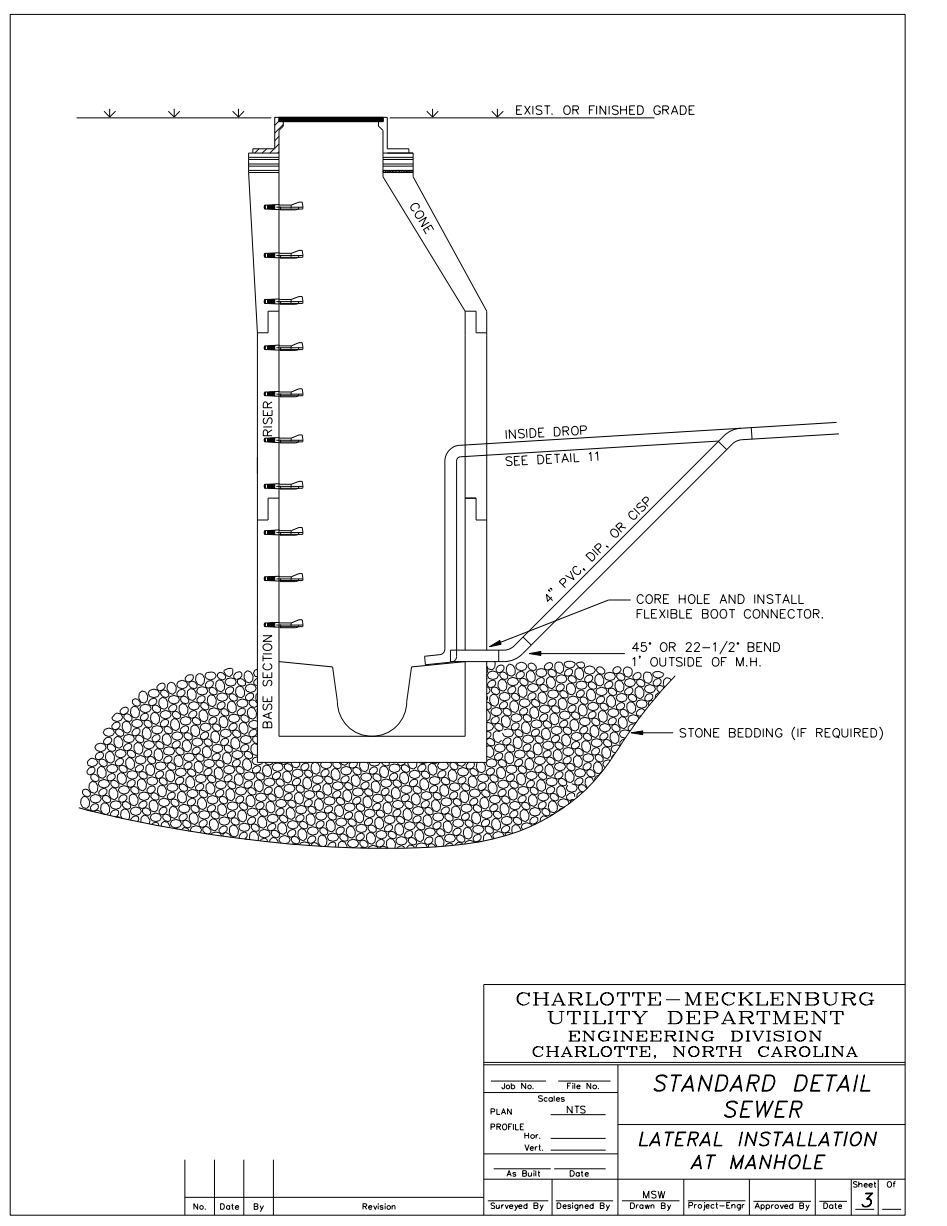
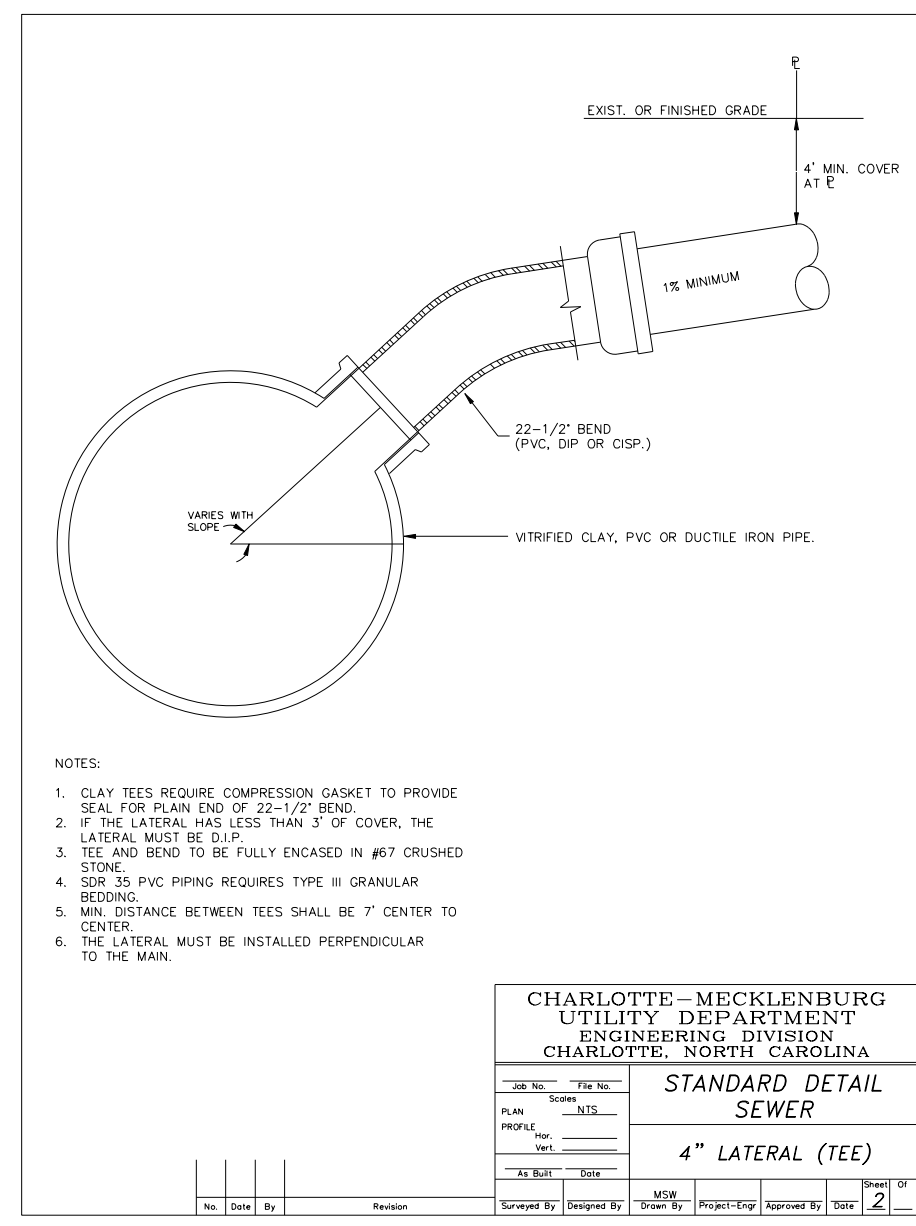
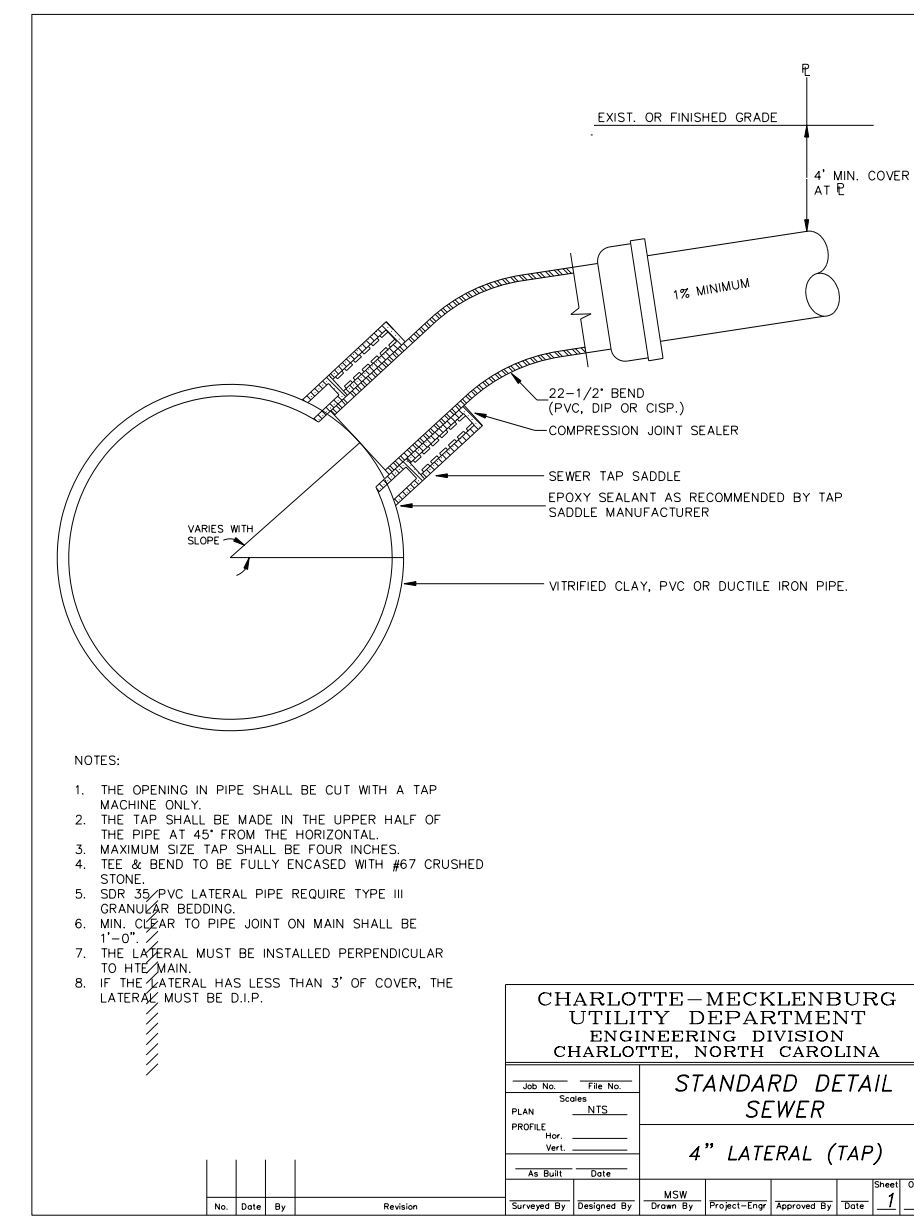
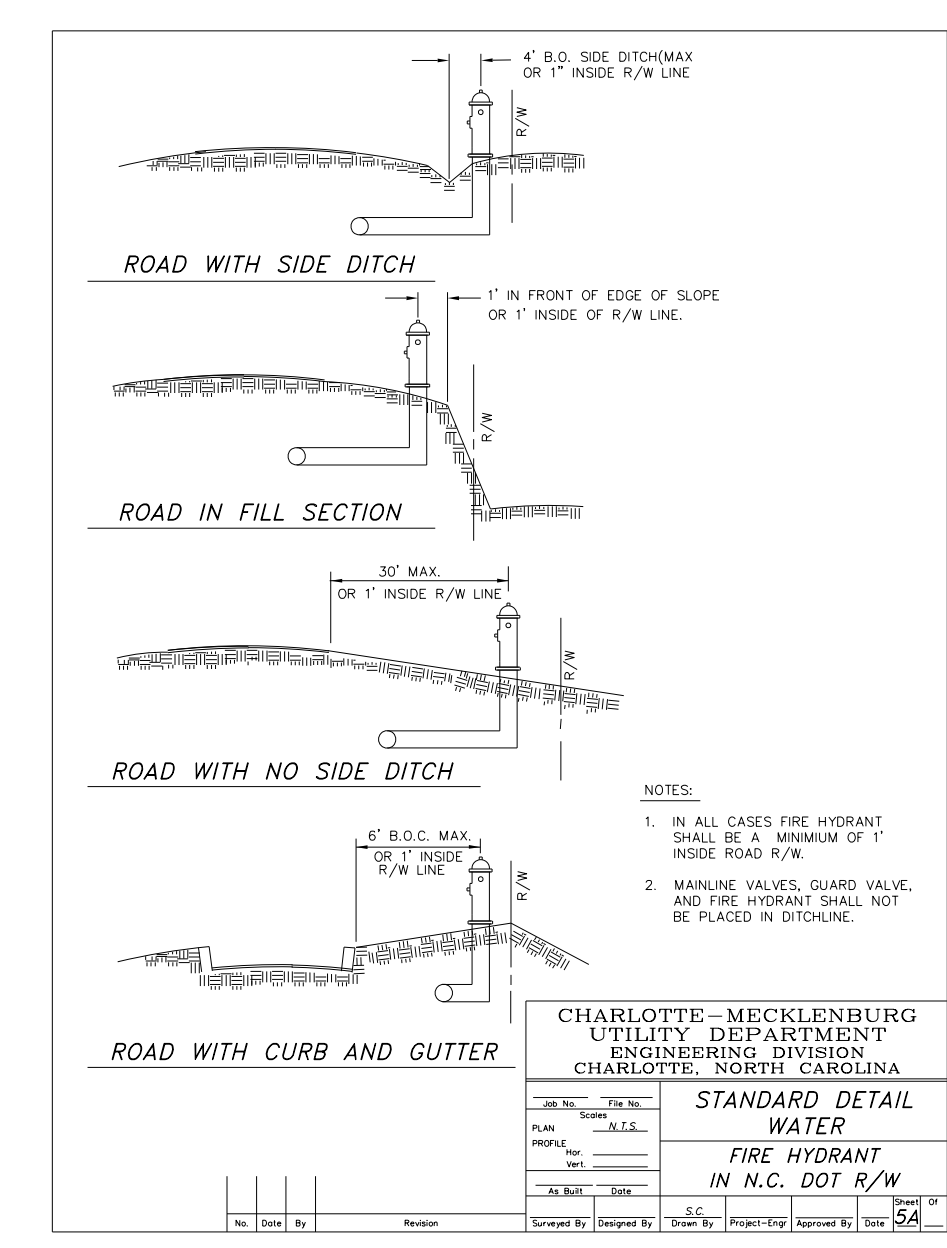
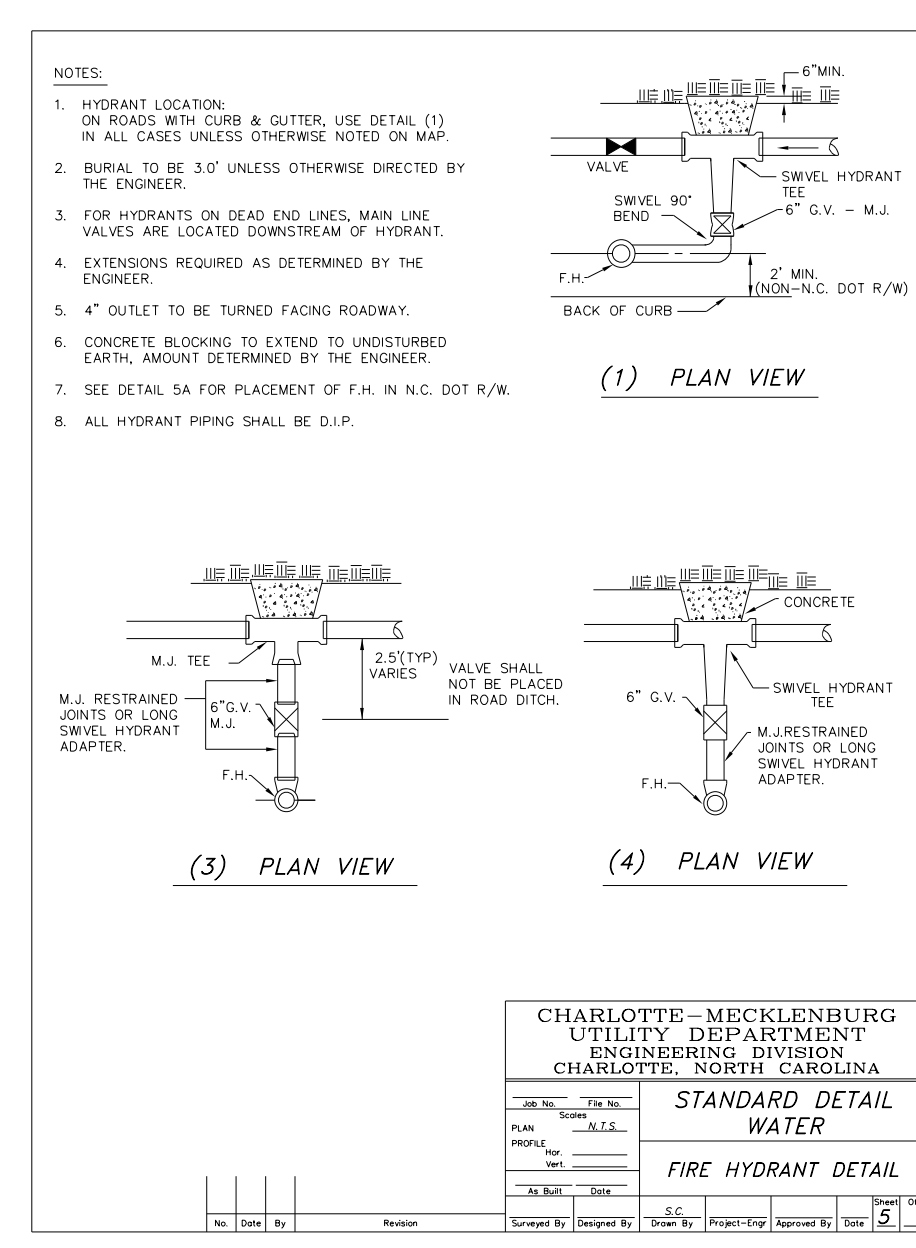
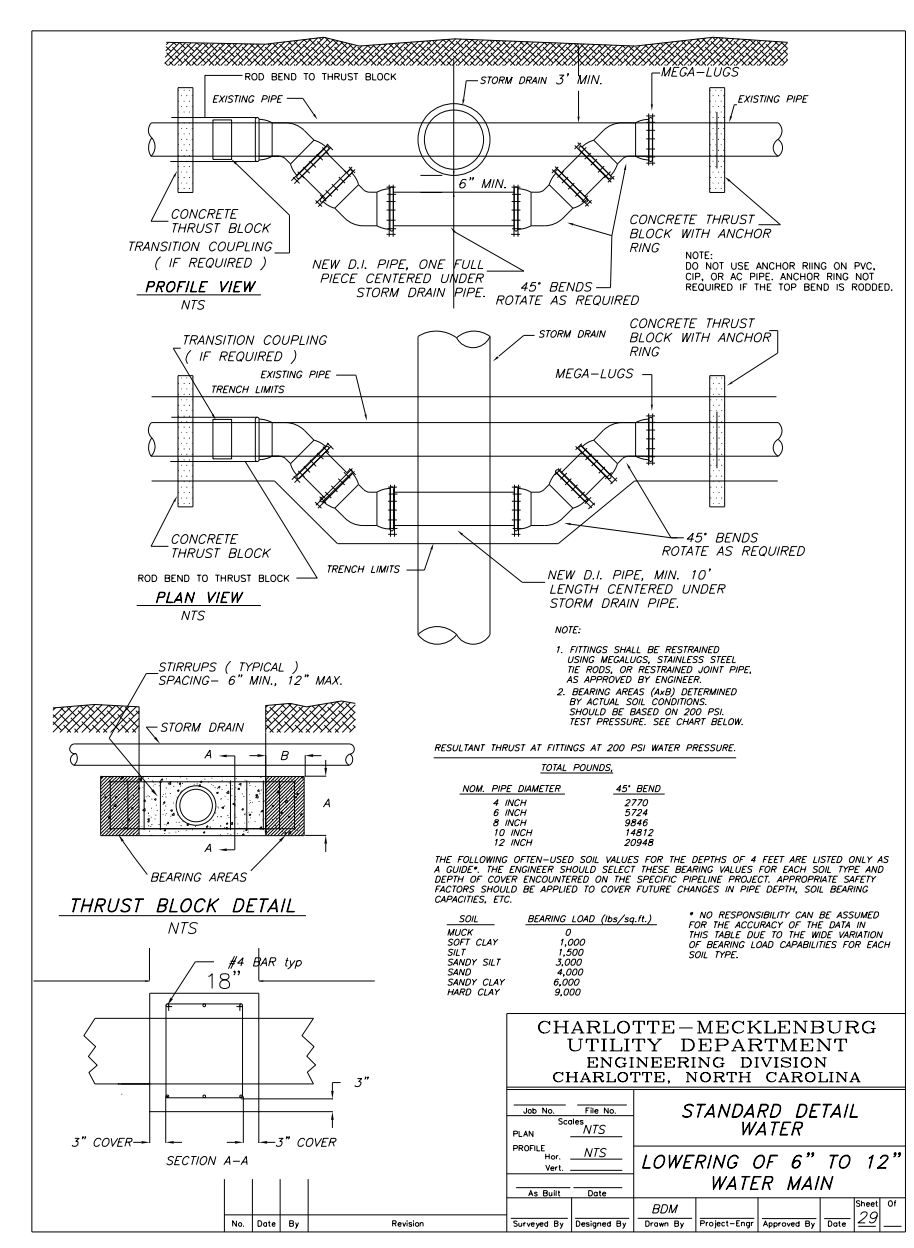

S:\JUN-2023-09-19-PROJECTS\2019\AZ2019205\00_CL\Water-C-5621\Design\Utilities\Engineering\UC-Proj\NC-5621\Ut_dtl\UC3a_psh.dgn