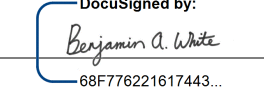
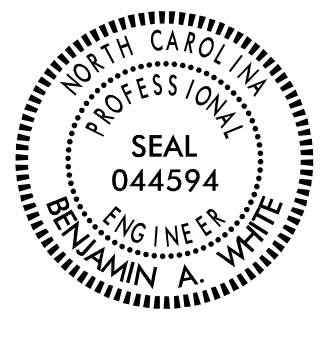

TIP NO.	SHEET NO.
HE-0011	PMP-1
APPROVED: 	DocuSigned by: Benjamin A. White 6B776221617443
DATE: 9/6/2023	
SEAL	
	
<b>DOCUMENT NOT CONSIDERED FINAL UNLESS ALL SIGNATURES COMPLETED</b>	

**STATE OF NORTH CAROLINA  
DEPARTMENT OF TRANSPORTATION**

**PAVEMENT MARKING PLAN  
CHATHAM COUNTY**

**LOCATION: CAM SITE ROADWAY IMPROVEMENTS  
ALONG US 64 JUST WEST OF SILER CITY**

**T.I.P.: HE-0011**

**CONTRACT:**

**INDEX**

SHEET NO.	DESCRIPTION
PMP-1	PAVEMENT MARKING PLAN INDEX, GENERAL NOTES, ROADWAY STANDARD DRAWINGS, AND PAVEMENT MARKING SCHEDULE
PMP-2	PAVEMENT MARKING DETAILS
PMP-3 TO PMP-6	PAVEMENT MARKING DETAILS

**ROADWAY STANDARD DRAWING**

THE FOLLOWING ROADWAY STANDARDS AS APPEAR IN "ROADWAY STANDARD DRAWINGS" - PROJECT SERVICES UNIT - N.C. DEPARTMENT OF TRANSPORTATION - RALEIGH, N.C., DATED JANUARY 2018 ARE APPLICABLE TO THIS PROJECT AND BY REFERENCE HEREBY ARE CONSIDERED A PART OF THESE PLANS:

STD. NO.	TITLE
1205.01	PAVEMENT MARKINGS - LINE TYPES AND OFFSETS
1205.02	PAVEMENT MARKINGS - TWO-LANE AND MULTILANE ROADWAYS
1205.04	PAVEMENT MARKINGS - INTERSECTIONS (SPECIAL DETAIL IN LIEU OF SHEET 2 OF 2)
1205.05	PAVEMENT MARKINGS - TURN LANES
1205.08	PAVEMENT MARKINGS - SYMBOLS AND WORD MESSAGES
1205.09	PAVEMENT MARKINGS - PAINTED ISLANDS
1205.15	PAVEMENT MARKINGS - SUPERSTREETS
1250.01	RAISED PAVEMENT MARKERS - INSTALLATION SPACING
1253.01	RAISED PAVEMENT MARKERS - SNOWPLOWABLE
1264.01	OBJECT MARKERS - TYPES
1264.02	OBJECT MARKERS - INSTALLATION

**GENERAL NOTES**

THE FOLLOWING GENERAL NOTES APPLY AT ALL TIMES FOR THE DURATION OF THE CONSTRUCTION PROJECT, EXCEPT WHEN OTHERWISE NOTED IN THE PLAN, OR DIRECTED BY THE ENGINEER.

A) INSTALL PAVEMENT MARKINGS AND PAVEMENT MARKERS ON THE FINAL SURFACE AS FOLLOWS:

ROAD NAME	MARKING	MARKER
(-L-) US 64	THERMOPLASTIC	SNOWPLOWABLE
(-Y1-) CAROLINA CORE PARKWAY	THERMOPLASTIC	SNOWPLOWABLE

- B) TIE PROPOSED PAVEMENT MARKING LINES TO EXISTING PAVEMENT MARKING LINES.
- C) REMOVE/REPLACE ANY CONFLICTING/DAMAGED PAVEMENT MARKINGS AND MARKERS.
- D) STOP BAR LOCATION AT NON-SIGNALIZED INTERSECTIONS MAY BE ADJUSTED AS DIRECTED BY THE ENGINEER.
- E) UNLESS OTHERWISE SPECIFIED, HEATED-IN-PLACE THERMOPLASTIC MAY BE USED IN LIEU OF EXTRUDED THERMOPLASTIC FOR STOP BARS, SYMBOLS, CHARACTERS AND DIAGONALS. IF HEATED-IN-PLACE IS USED, IT SHALL BE PAID FOR USING THE EXTRUDED THERMOPLASTIC PAY ITEM.

**PAVEMENT MARKING AND  
MARKER SCHEDULE**

SYMBOL	DESCRIPTION
T20	THERMOPLASTIC WHITE EDGELINE (6", 90 MIL)
T21	THERMOPLASTIC WHITE SOLID LANE LINE (6", 90 MIL)
T22	THERMOPLASTIC 10 FT. WHITE SKIP (6", 90 MIL)
T23	THERMOPLASTIC 3 FT. - 9 FT./SP WHITE MINISKIP (6", 90 MIL)
T24	THERMOPLASTIC 2 FT. - 6 FT./SP WHITE MINISKIP (6", 90 MIL)
T30	THERMOPLASTIC YELLOW EDGELINE (6", 90 MIL)
T34	THERMOPLASTIC 2 FT. - 6 FT./SP YELLOW MINISKIP (6", 90 MIL)
T50	THERMOPLASTIC WHITE GORELINE (12", 90 MIL)
T51	THERMOPLASTIC WHITE DIAGONAL (12", 90 MIL)
T61	THERMOPLASTIC WHITE STOPBAR (24", 90 MIL)
T70	THERMOPLASTIC LEFT TURN ARROW (90 MIL)
T71	THERMOPLASTIC RIGHT TURN ARROW (90 MIL)
T72	THERMOPLASTIC STRAIGHT ARROW (90 MIL)
T77	THERMOPLASTIC U-TURN ARROW (90 MIL)
MF	SNOWPLOWABLE MARKER - CRYSTAL & RED

PLAN PREPARED BY:



RICKY A. TIPTON, PE PROJECT ENGINEER  
BENJAMIN A. WHITE, PE PROJECT DESIGN ENGINEER

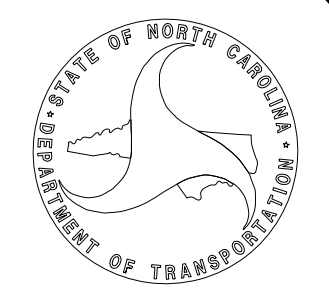

7/27/2023 1:51:00 PM User: bwhite

TIP NO.	SHEET NO.
HE-0011	PMP-2
APPROVED: <i>Matthew Y. Springer</i>	
DATE: 8/13/2019	
	

STATE OF NORTH CAROLINA  
 DEPT. OF TRANSPORTATION  
 DIVISION OF HIGHWAYS  
 RALEIGH, N.C.



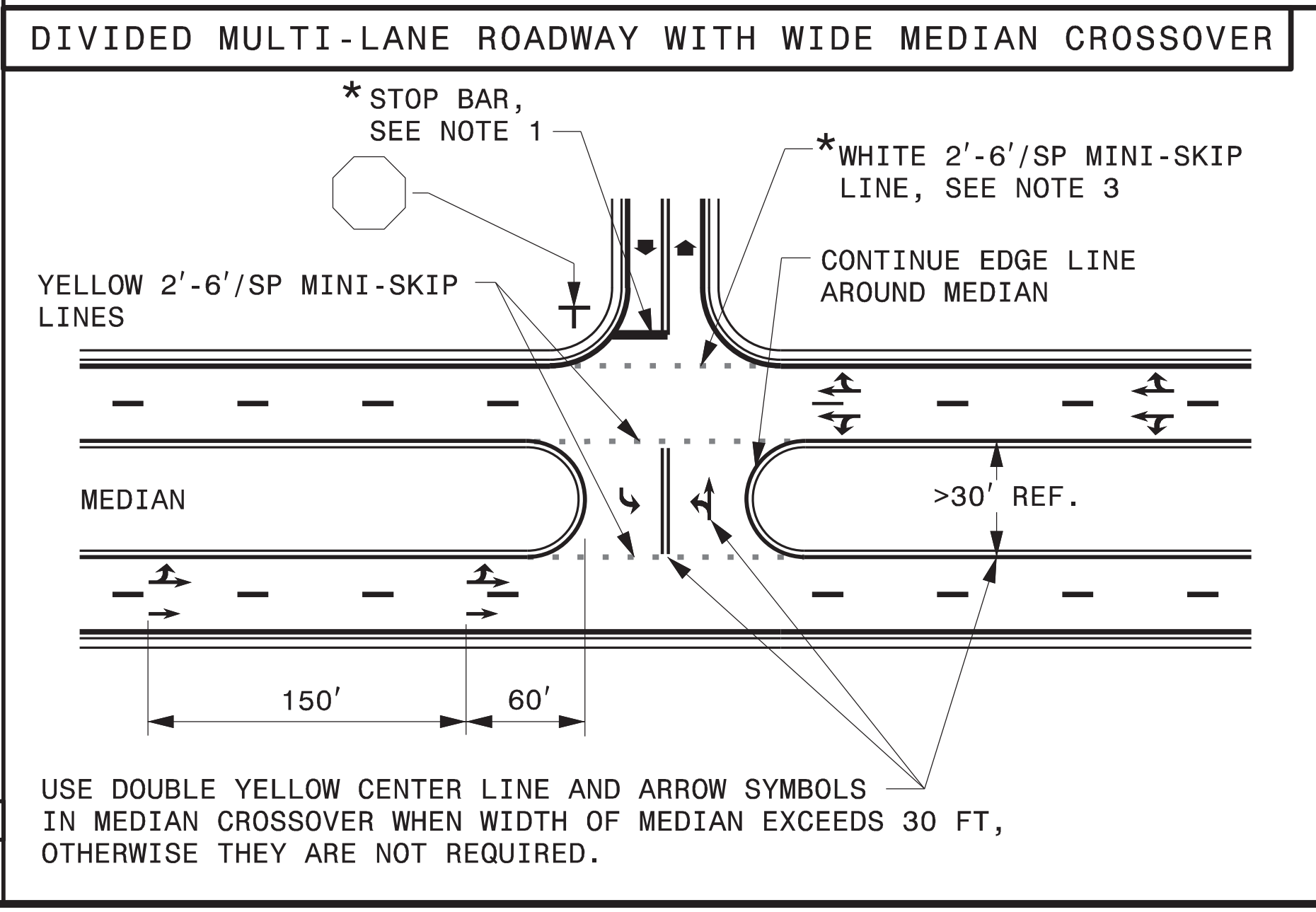
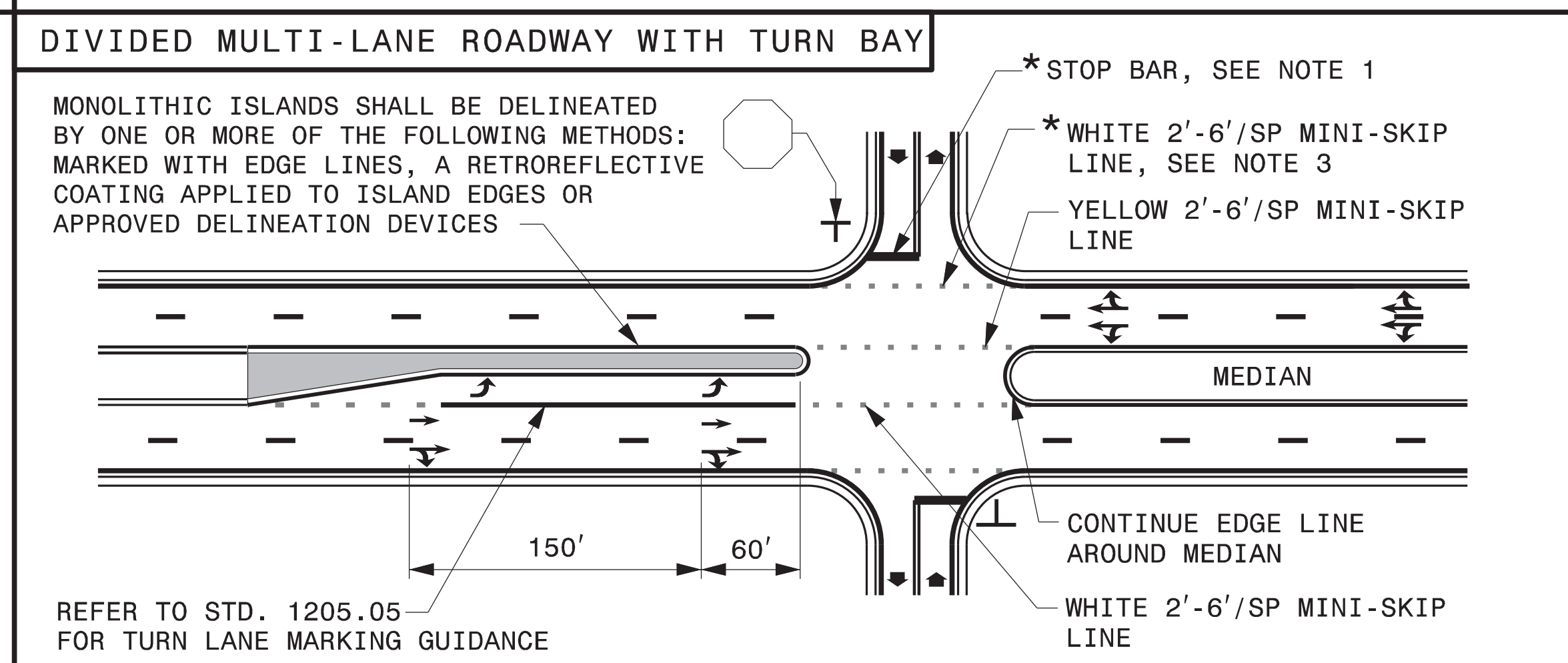
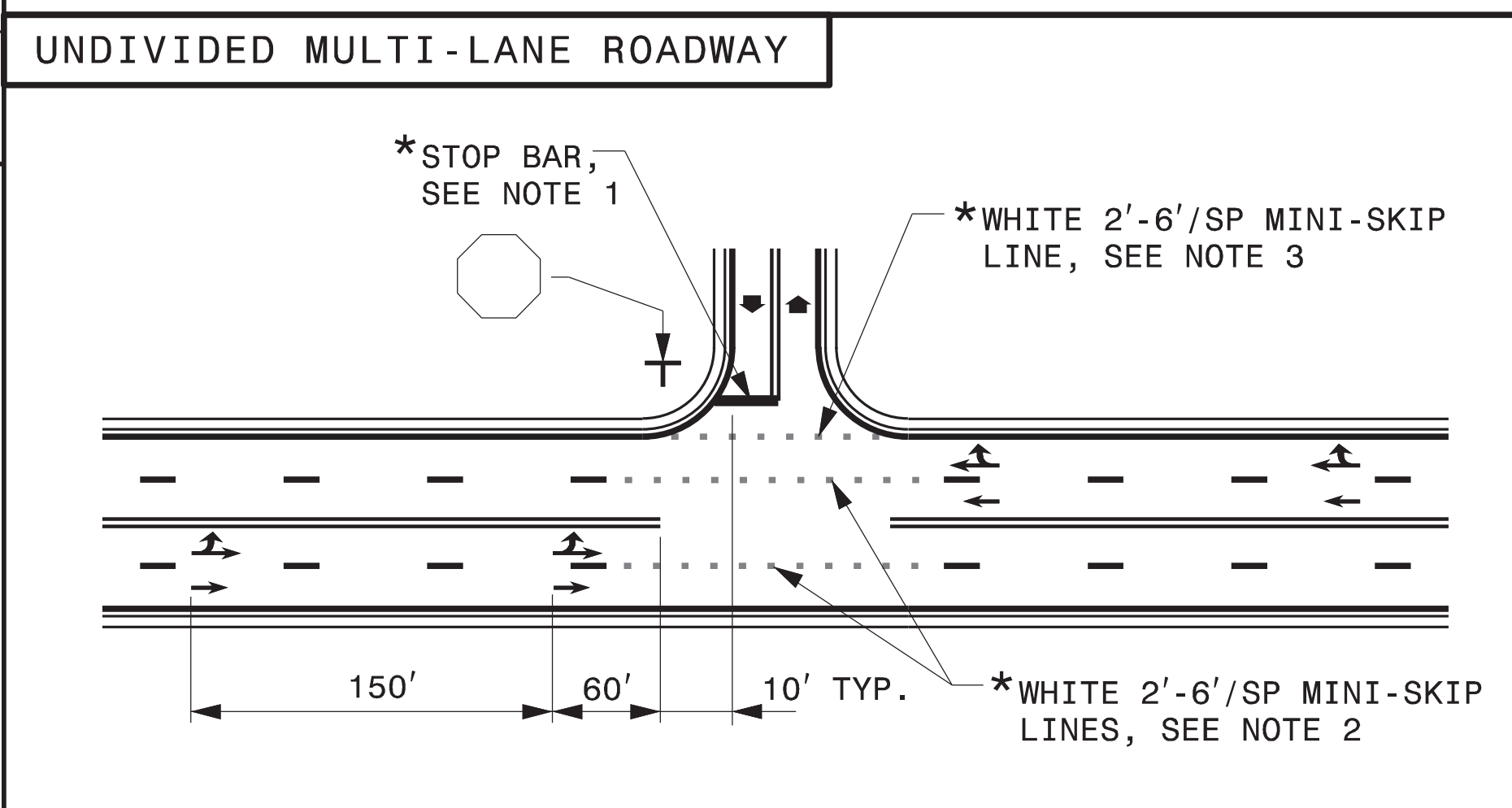
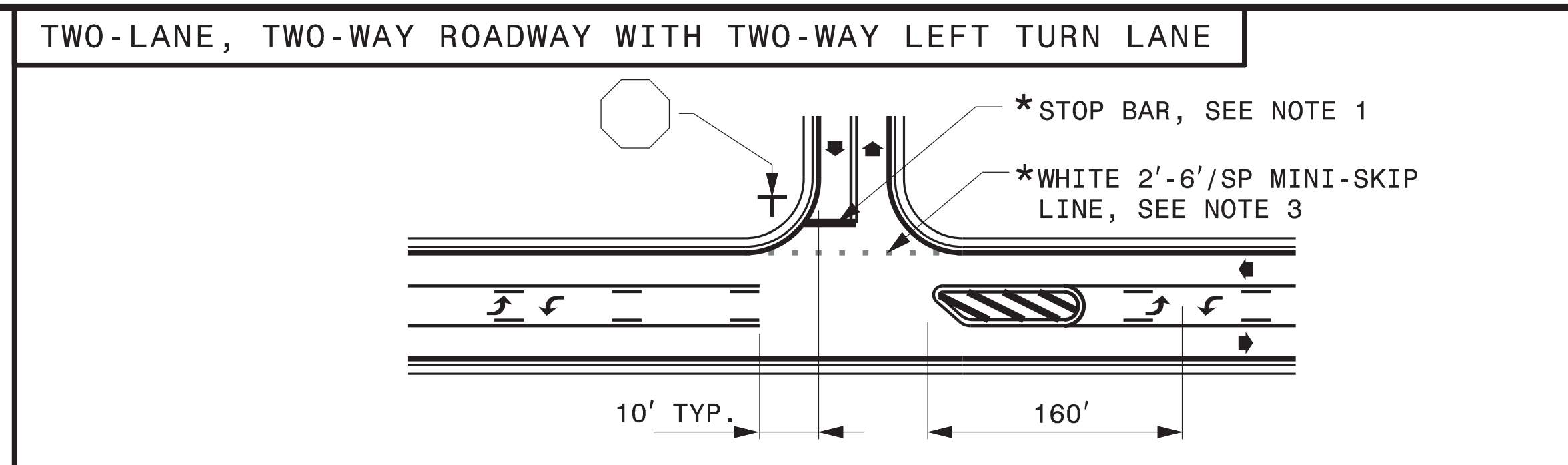
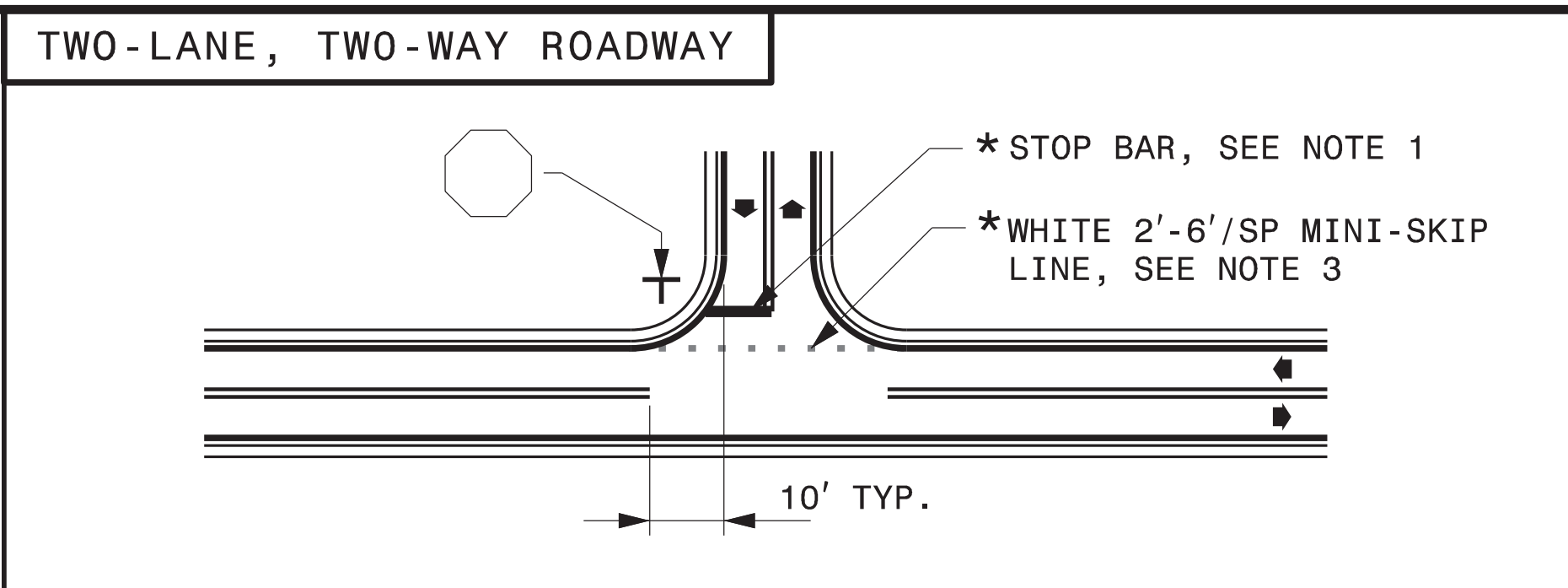

ENGLISH DETAIL DRAWING FOR  
**PAVEMENT MARKINGS**  
 INTERSECTIONS

SHEET 2 OF 2  
**1205D04**

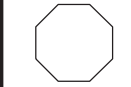

**GENERAL NOTES:**

- 1- PLACEMENT OF STOP BARS AT NON-SIGNALIZED INTERSECTIONS IS OPTIONAL AND USED WHERE IT IS IMPORTANT TO INDICATE THE POINT WHICH VEHICLES ARE REQUIRED TO STOP. PLACE STOP BARS NO LESS THAN 4 FEET AND NO MORE THAN 30 FEET FROM THE NEAREST EDGE OF THE INTERSECTING ROADWAY. USE 10 FEET AS THE TYPICAL SETBACK DISTANCE OR AS DIRECTED BY THE ENGINEER.
- 2- MINI-SKIP LANE LINE EXTENSIONS SHOULD BE USED AT INTERSECTIONS THAT HAVE REDUCED VISIBILITY CONDITIONS SUCH AS OFFSET, SKEWED, OR CURVED ROADWAYS.
- 3- MINI-SKIP EDGE LINE EXTENSIONS MAY BE PLACED THROUGH INTERSECTIONS AND MAJOR DRIVEWAYS.
- 4- REFER TO ROADWAY STANDARD DRAWINGS 1205.01, 1205.02, 1205.05, 1205.08 AND 1205.09 FOR ADDITIONAL PAVEMENT MARKING GUIDANCE.

LEGEND	
 STOP SIGN	 STATIONARY SIGN
 DIRECTION OF TRAFFIC FLOW	 PAVEMENT MARKING SYMBOLS
* OPTIONAL	

SHEET 2 OF 2  
**1205D04**

STATE OF NORTH CAROLINA  
 DEPT. OF TRANSPORTATION  
 DIVISION OF HIGHWAYS  
 RALEIGH, N.C.

ENGLISH DETAIL DRAWING FOR  
**PAVEMENT MARKINGS**  
 INTERSECTIONS

SHEET 2 OF 2  
**1205D04**

**REVISED PAVEMENT MARKING  
ROADWAY STANDARD DRAWING**



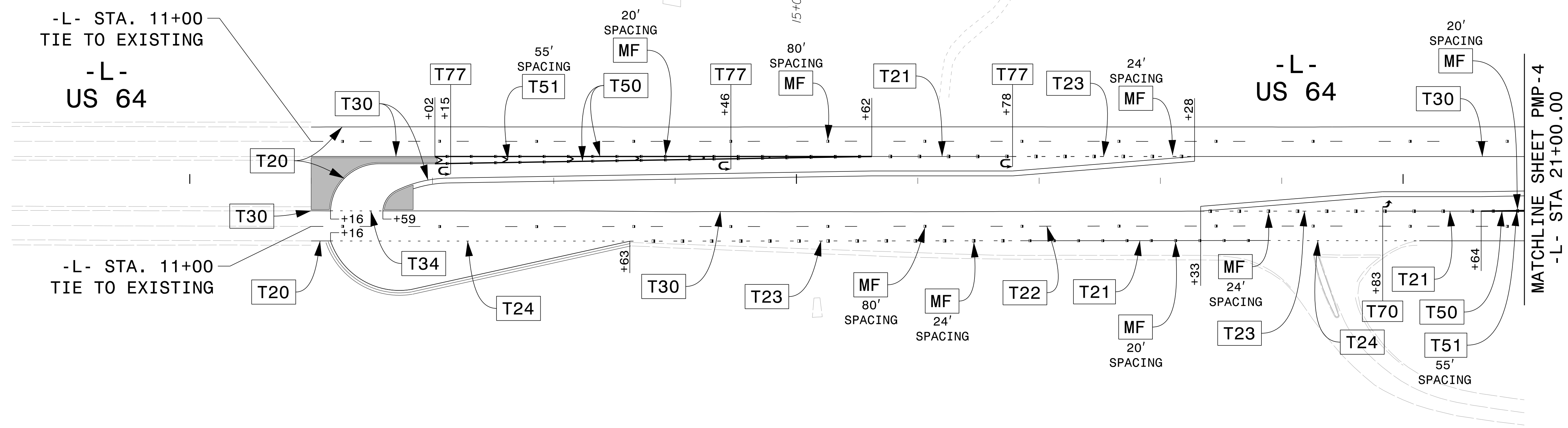



9/6/2023 10:56:25 AM User: bawhite

NOTE: ALL LANE WIDTHS ARE 12' UNLESS OTHERWISE SHOWN

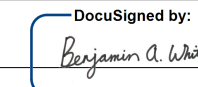
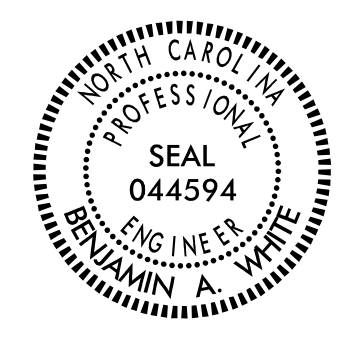
**PAVEMENT MARKING DETAIL**

TIP NO. HE - 0011	SHEET NO. PMP - 4
APPROVED:  <small>DocuSigned by: Benjamin A. White 68F77021617443 9/6/2023</small>	
DATE: 9/6/2023	
SEAL 	
DOCUMENT NOT CONSIDERED FINAL UNLESS ALL SIGNATURES COMPLETED	
 <small>One Glenwood Avenue Suite 900 Raleigh, NC 27603 919-420-7660 NC Lic. No. F-0270</small>	

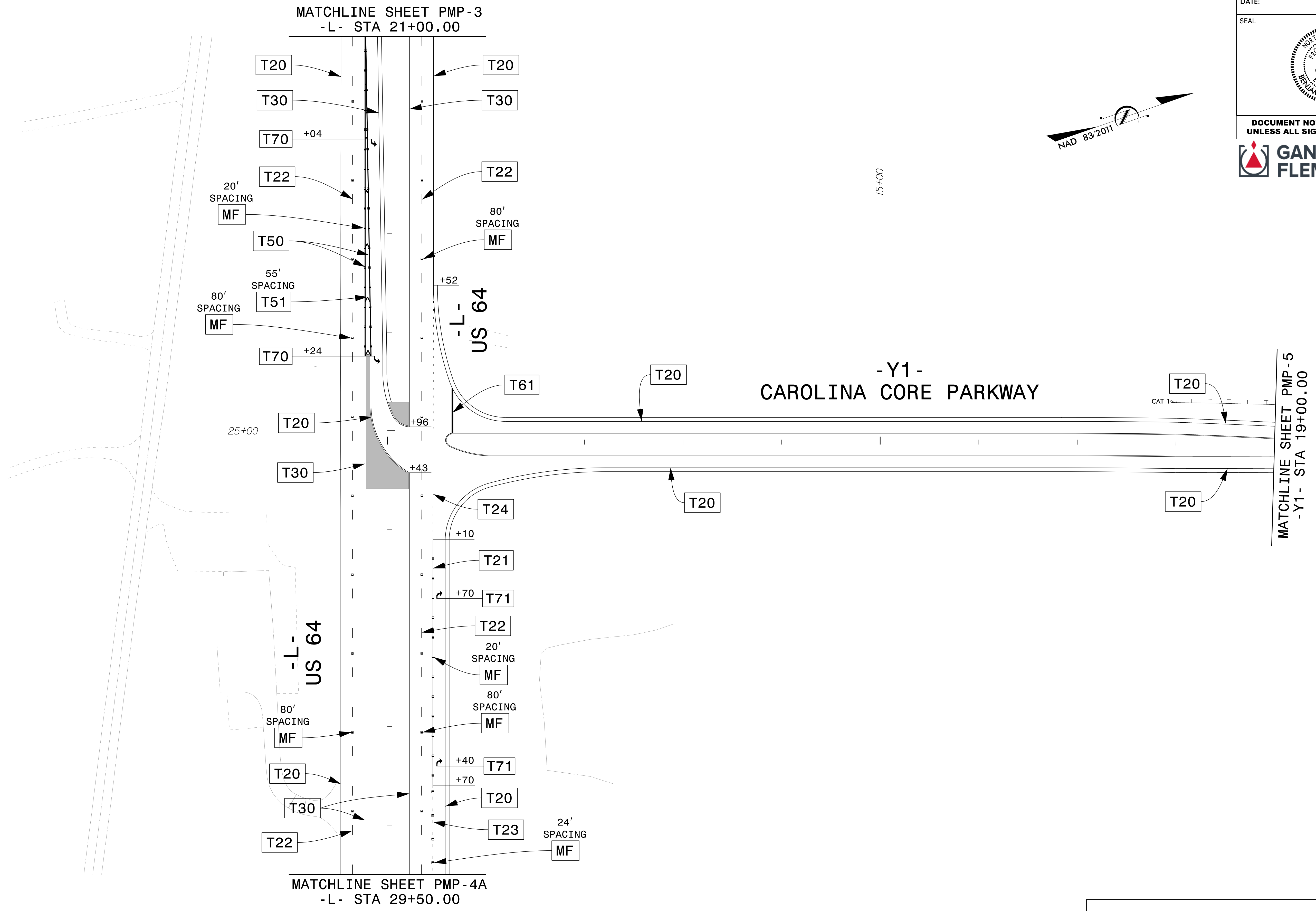
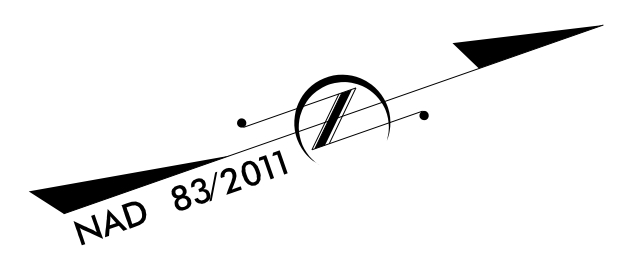

8/22/2023  
 User: bawhite  
 C:\Users\Bentley\Documents\Projects\69172\5-Working\Task 017 - Chatham County Site\Traffic\TrafficControl\PMP\HE-0011.pmp\_psh04\_2 LANES NARROW.dgn

NOTE: ALL LANE WIDTHS ARE 12'  
UNLESS OTHERWISE SHOWN

**PAVEMENT MARKING DETAIL**

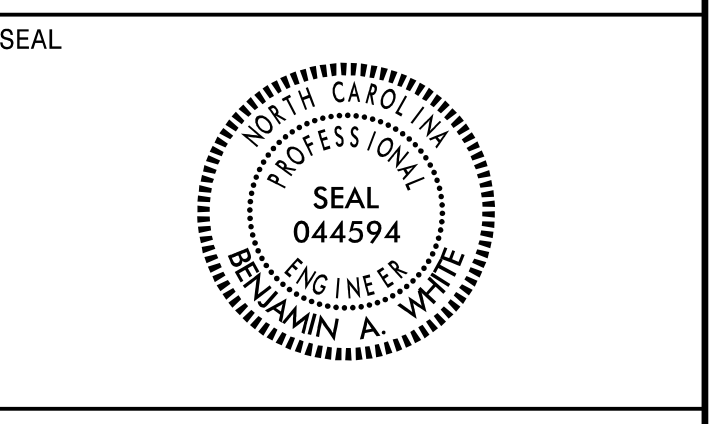

**DOCUMENT NOT CONSIDERED FINAL  
UNLESS ALL SIGNATURES COMPLETED**

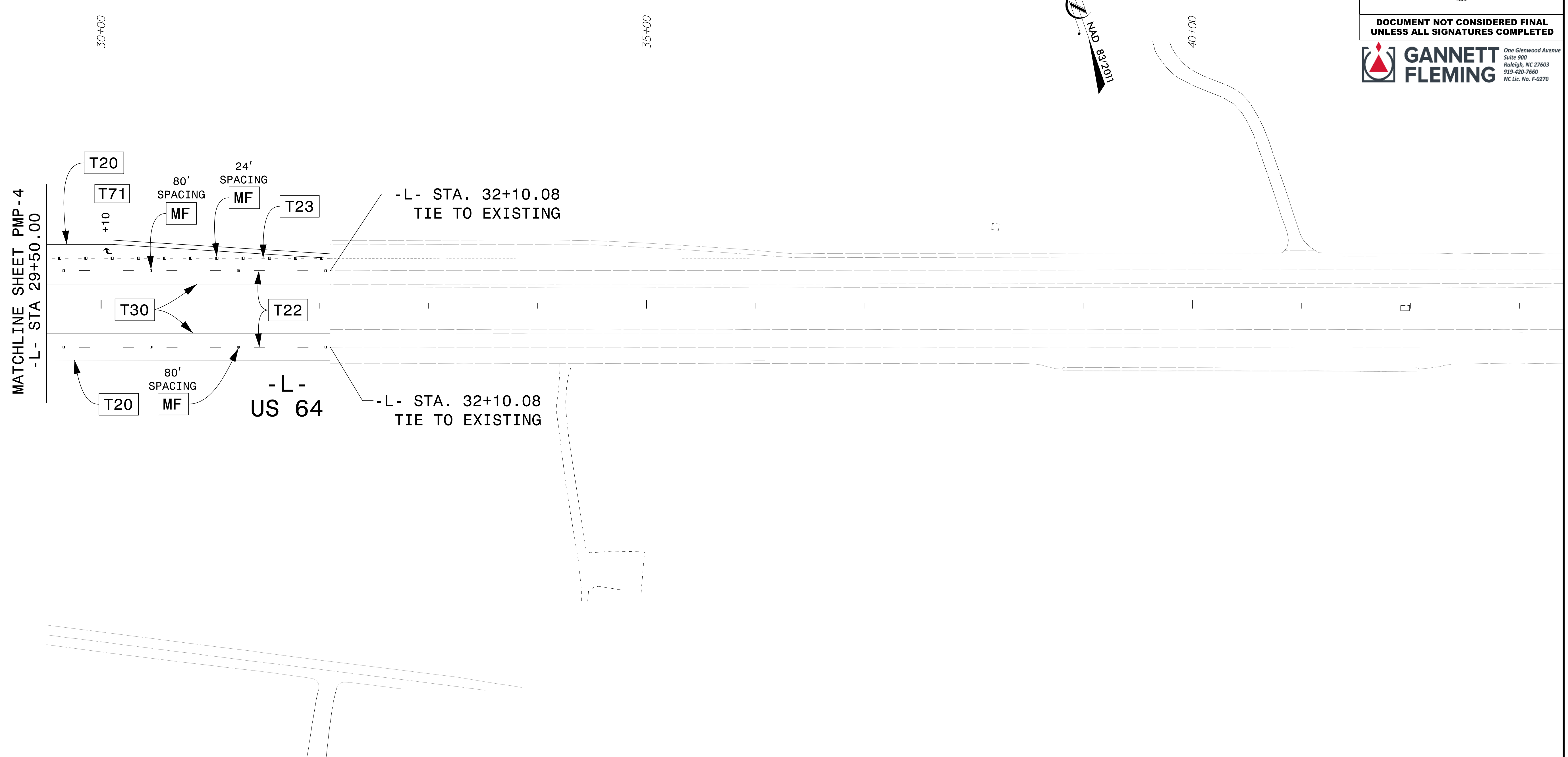

7/27/2023  
 User: bwhite  
 C:\Users\bwhite\Documents\Projects\69172\5-Working\Task 017 - Chatham County Site\Traffic\TrafficControl\PMP\HE-0011.pmp\_psh04a.dgn

NOTE: ALL LANE WIDTHS ARE 12'  
UNLESS OTHERWISE SHOWN

**PAVEMENT MARKING DETAIL**

TIP NO. HE - 0011	SHEET NO. PMP - 5
----------------------	----------------------

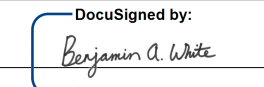
APPROVED:   
 DATE: 9/6/2023

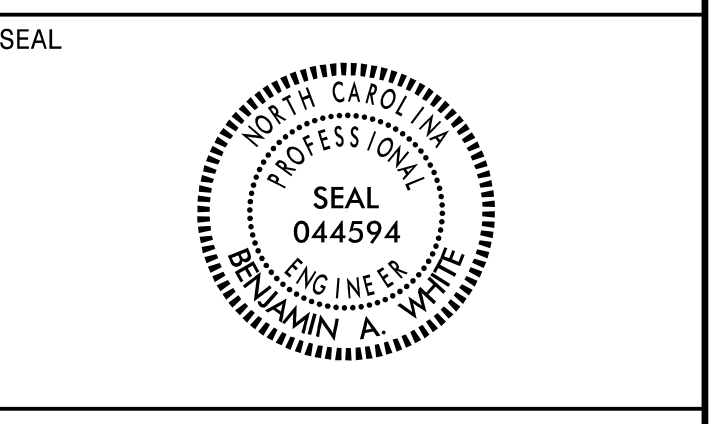

**DOCUMENT NOT CONSIDERED FINAL  
UNLESS ALL SIGNATURES COMPLETED**

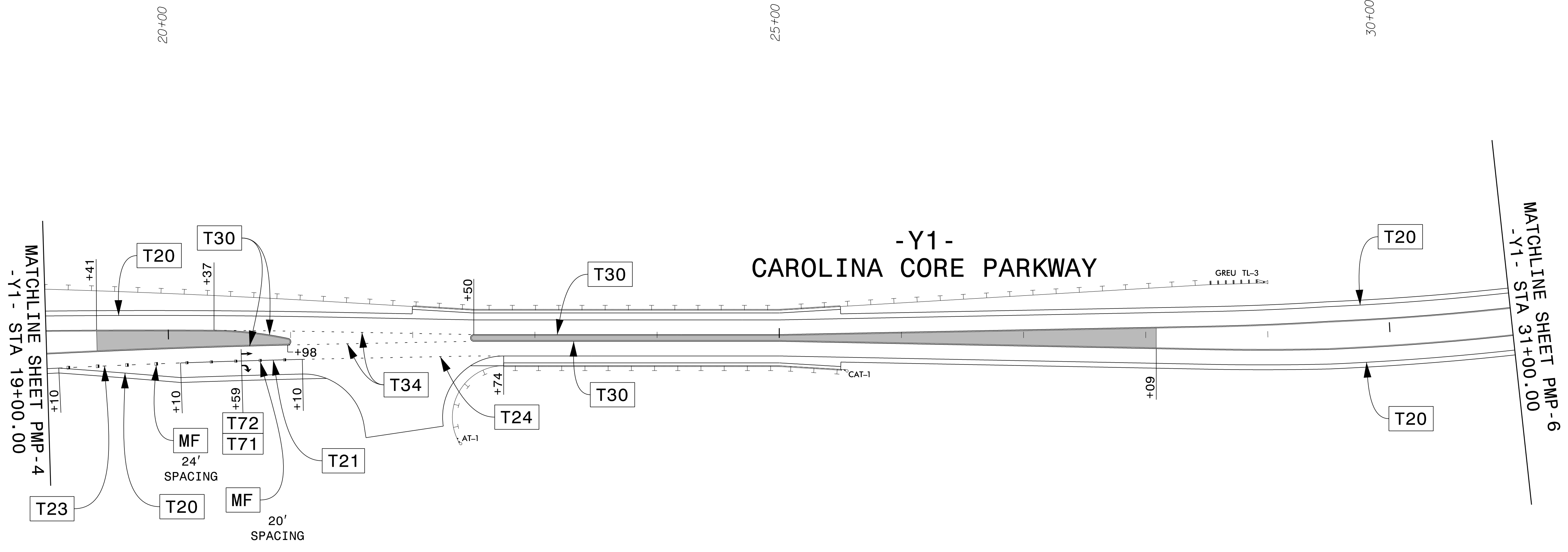
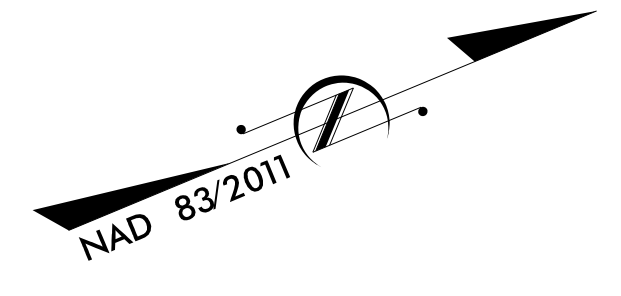

8/22/2023 10:56:25 AM User: bawhite  
 C:\Users\Bentley\Documents\Projects\69172\5-Working\Task 017 - Chatham County Site\Traffic\TrafficControl\PMP\HE-0011.pmp\_psh05\_2 LANES NARROW.dgn

NOTE: ALL LANE WIDTHS ARE 12'  
UNLESS OTHERWISE SHOWN

**PAVEMENT MARKING DETAIL**

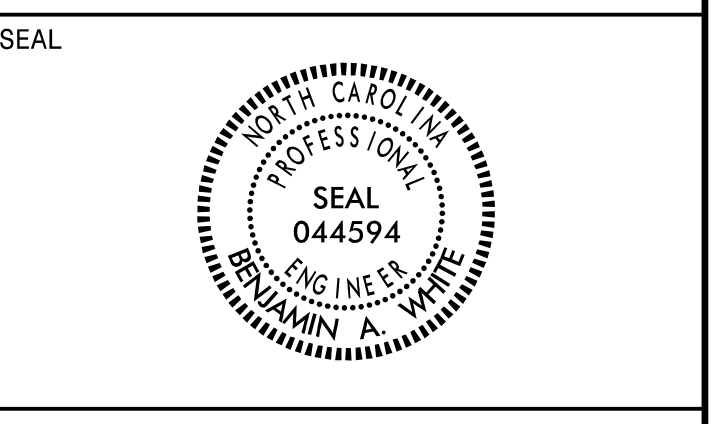

**DOCUMENT NOT CONSIDERED FINAL  
UNLESS ALL SIGNATURES COMPLETED**

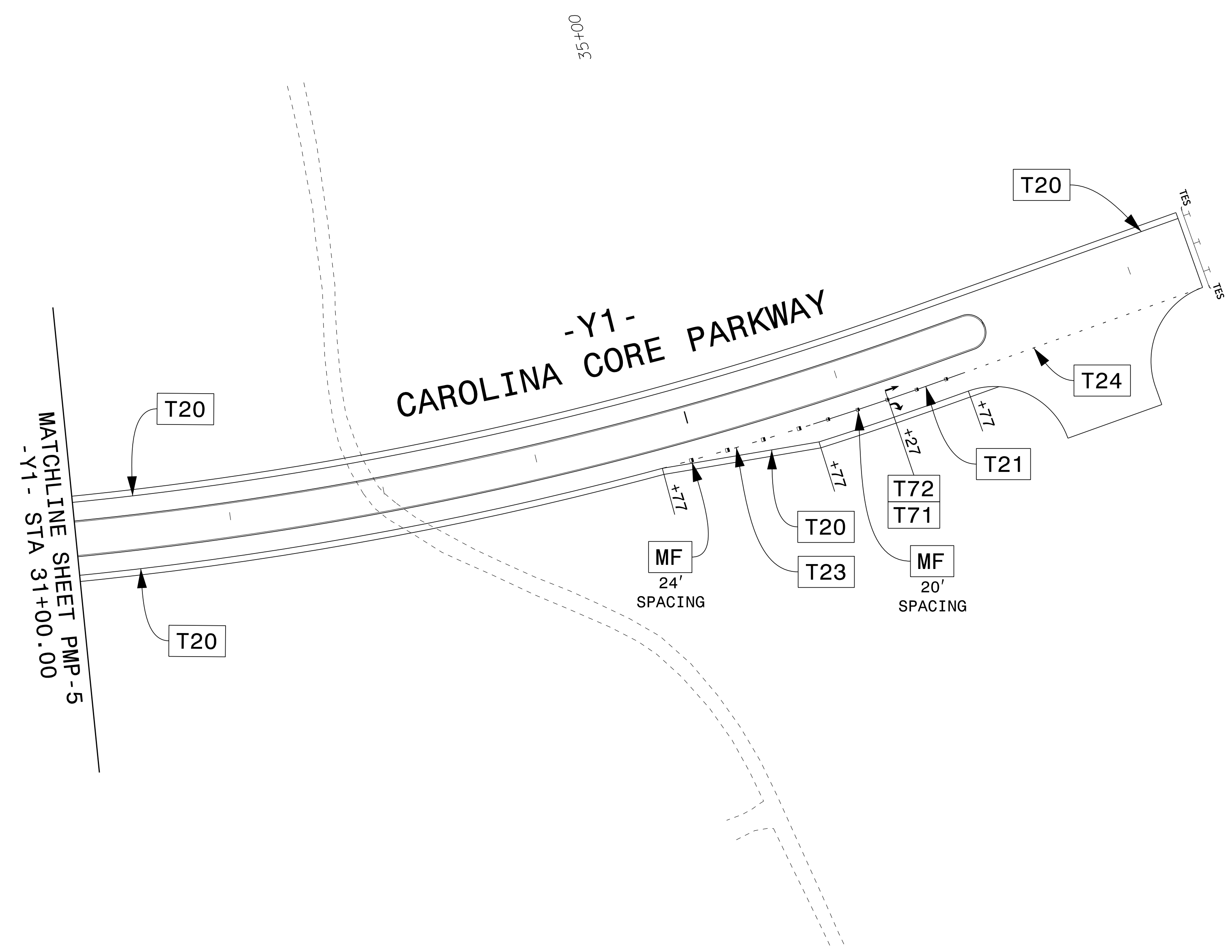
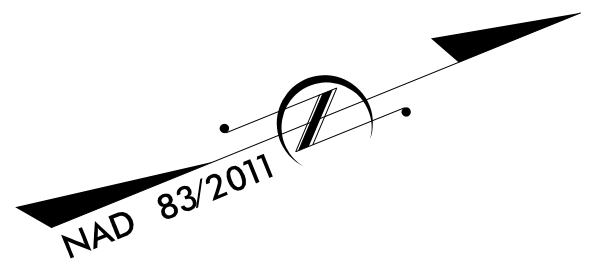

NOTE: ALL LANE WIDTHS ARE 12'  
UNLESS OTHERWISE SHOWN

**PAVEMENT MARKING DETAIL**

7/27/2023  
pw.bentley.com:gnfnet+pw-0\Documents\Projects\69172\5-Working\Task 017 - Chatham County Site\Traffic\TrafficControl\PMP\HE-0011.pmp\_psh06.dgn  
User: bwhite