

Note:
 1. Opening in pole base plate shall be equal to pole base inside diameter minus 3 1/2" but shall not be less than 8 1/2".

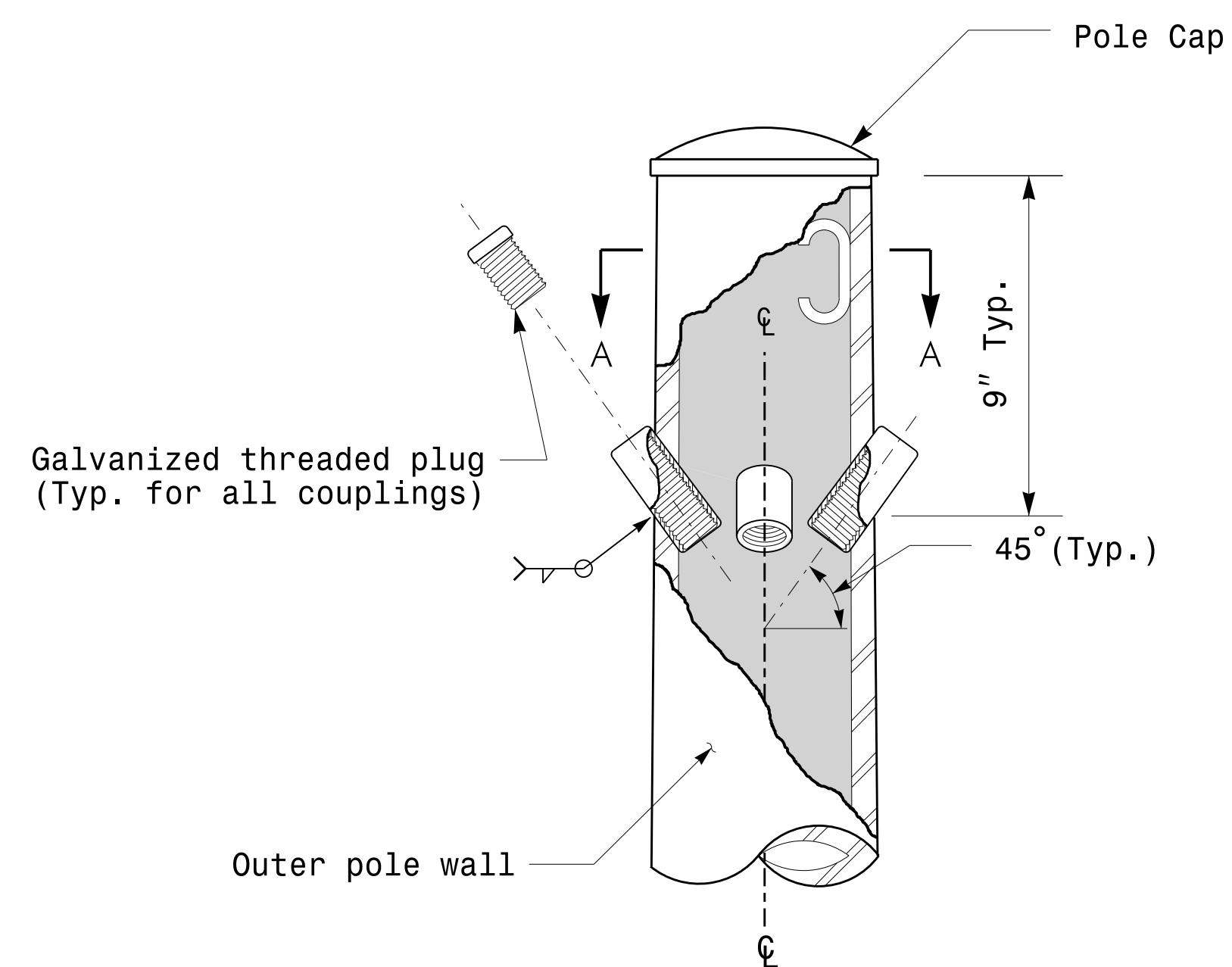

Cable Entrances at Top of Pole

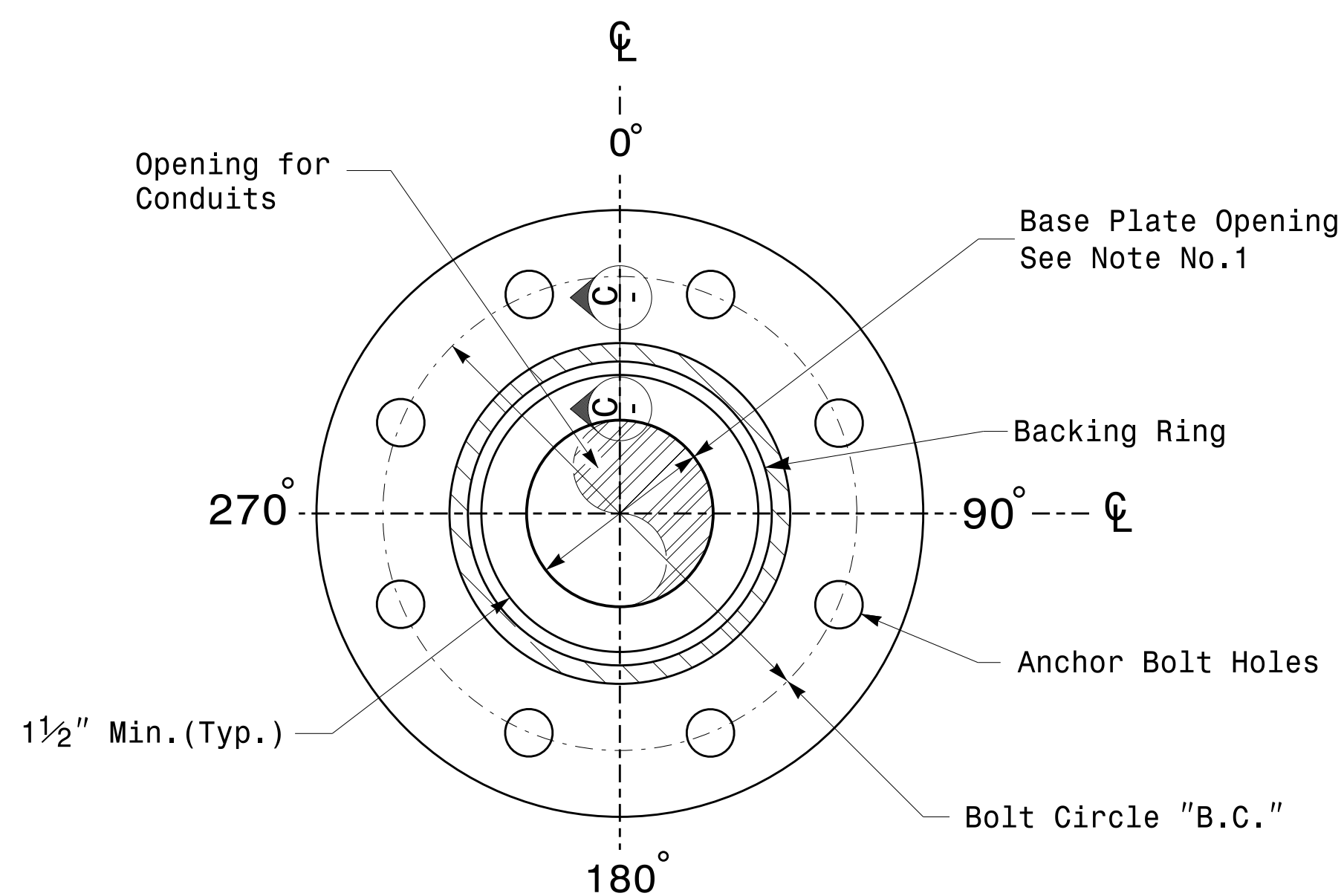

Section B-B
Pole Base Plate Details
(8 and 12 Bolt Pattern)

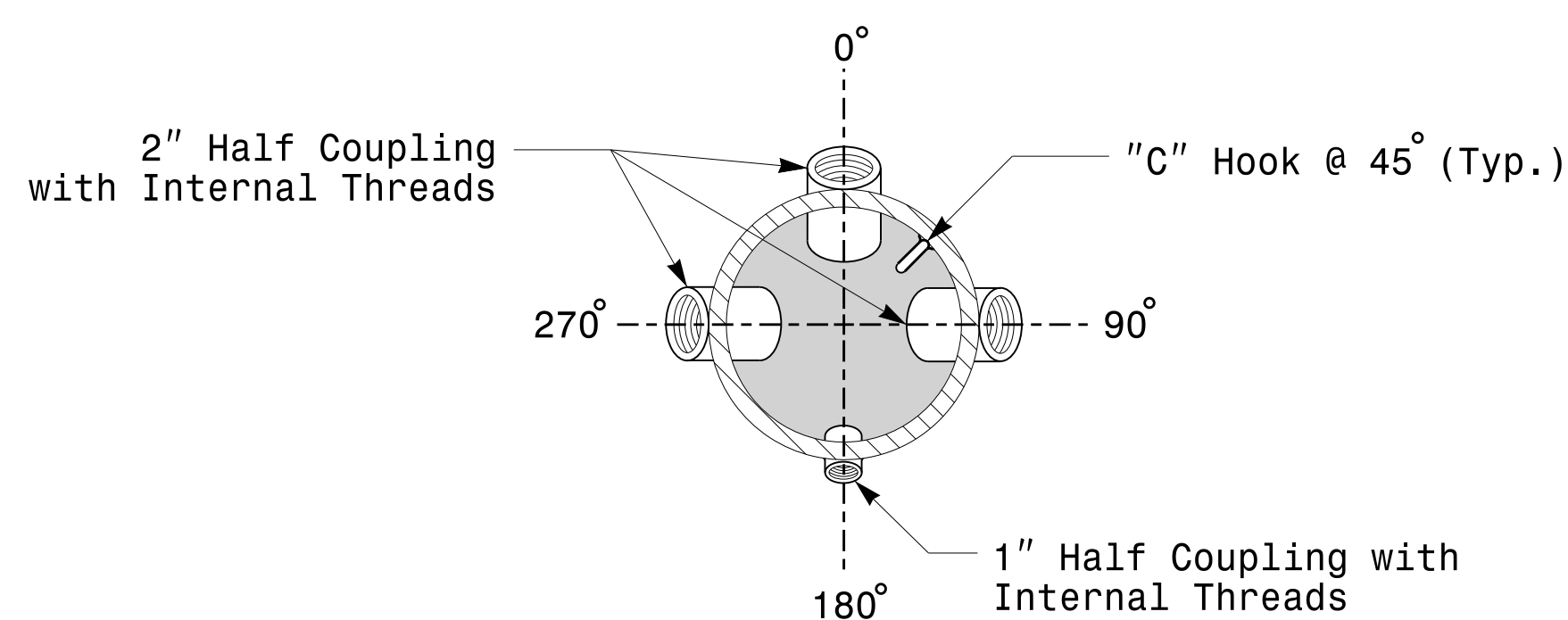

Section A-A
Radial Orientation for Factory Installed
Accessories at Top of Pole

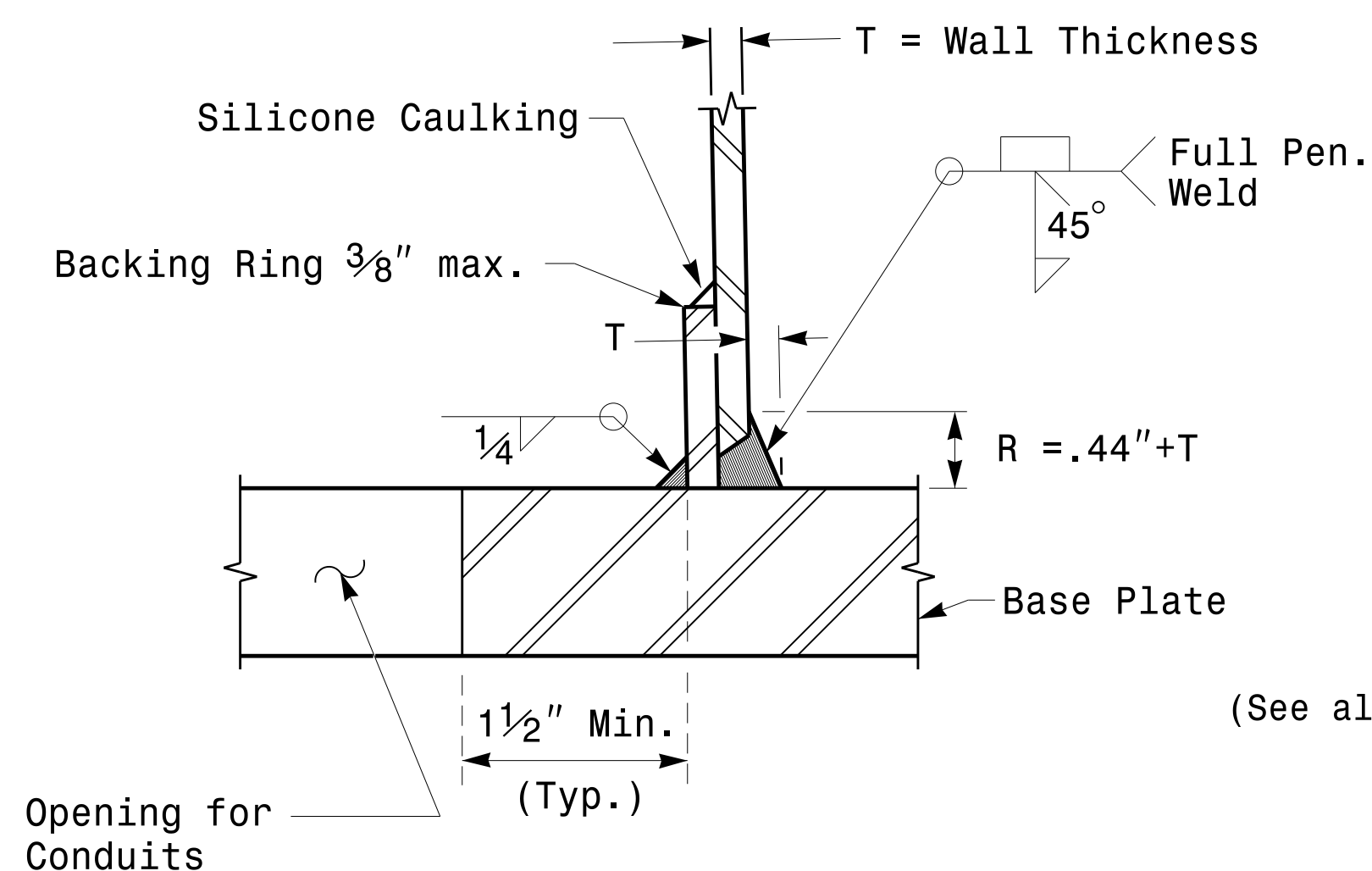

Section C-C
(Pole Attachment to Base Plate)
Full-Penetration
Groove Weld Detail

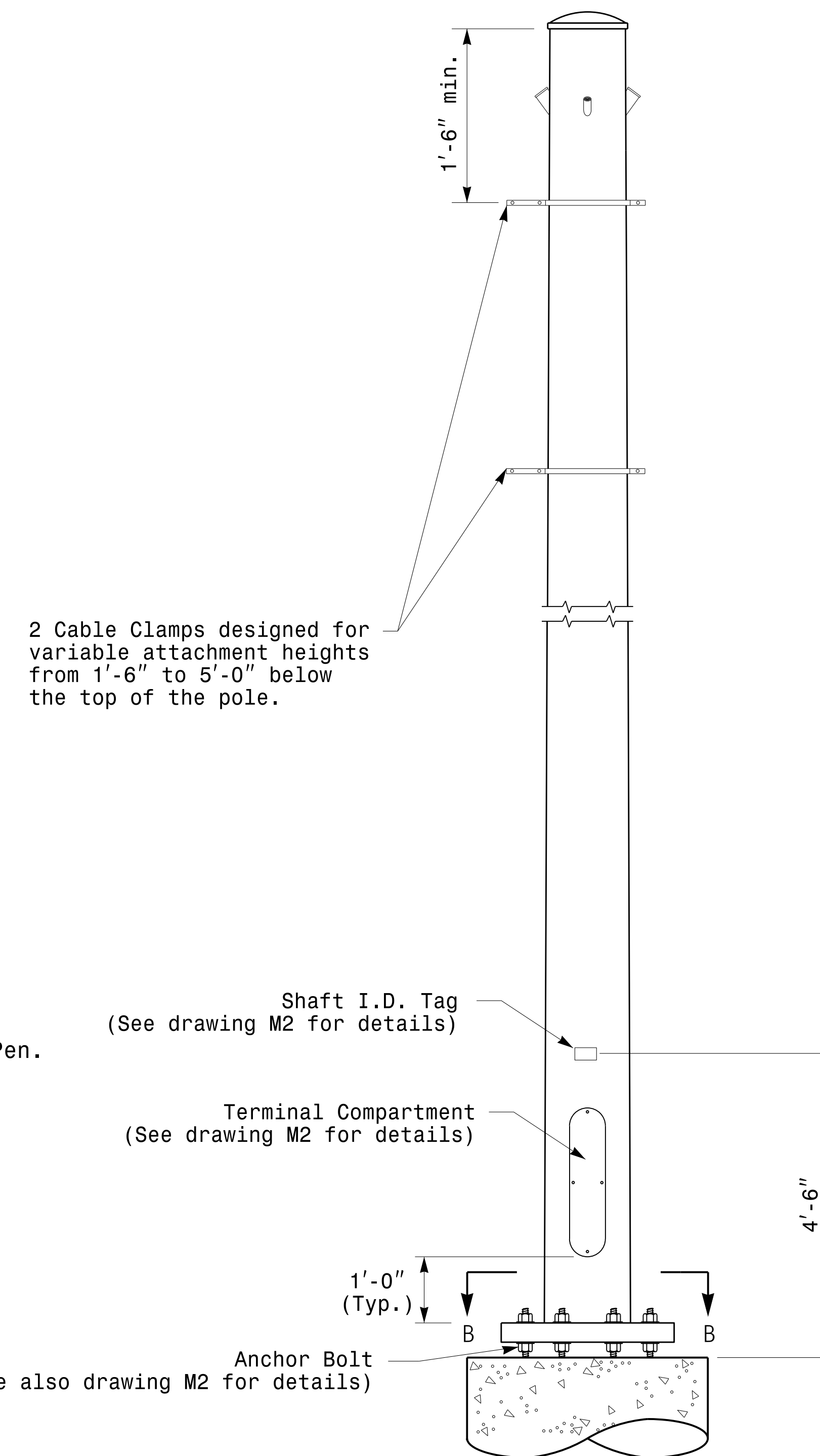

Monotube Strain Pole

Prepared in the Offices of:

 750 N. Greenleaf Pkwy, Garner, NC 27529

SCALE: NONE

Typical Fabrication Details For Strain Poles

PLAN DATE: OCTOBER 2017	DESIGNED BY: K.C. DURIGON
PREPARED BY: N. BITTING	REVIEWED BY: D.C. SARKAR
REVISIONS	INIT. DATE

SEAL

DocuSigned by:
 Debesh C. Sarkar
 44EB87816FA4F49E

10/11/2017
 DATE

Fabrication Details – Strain Poles