

NOTES:
FOR NOTES, SEE SHEET 2 OF 3

DATE: 2/10/2023
TIME: 10:24 PM

USER: c:\pwworkspace\john.morrison\AutoCAD\Drawings\402-L-11-5748-SMU-AS1-S2-50-91031
DWG: pwworkspace\john.morrison\AutoCAD\Drawings\402-L-11-5748-SMU-AS1-S2-50-91031
DATE: 2/10/2023

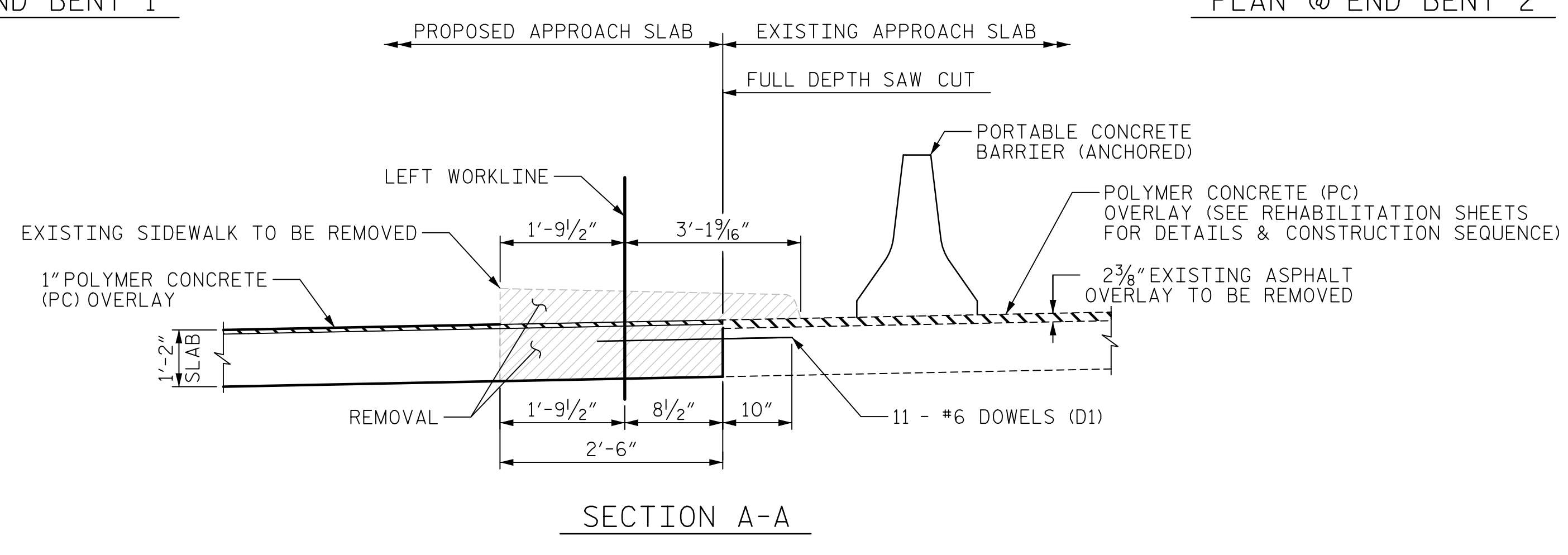
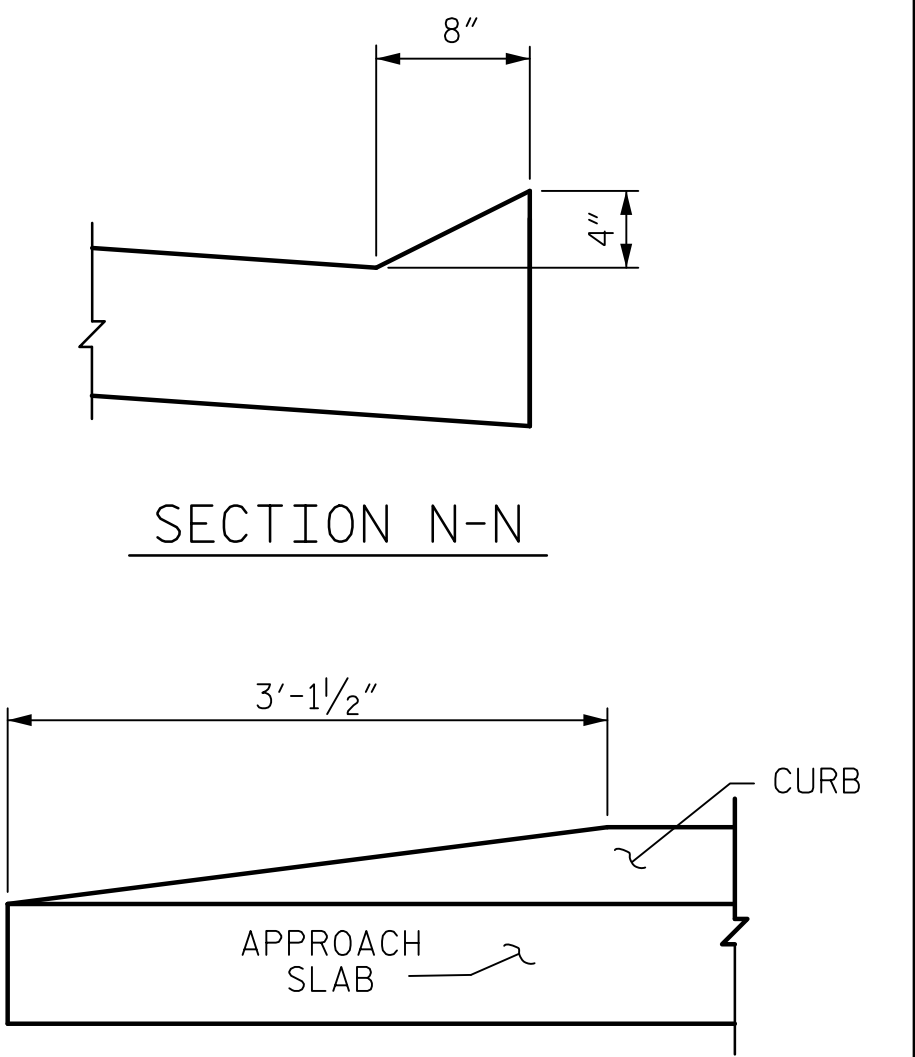
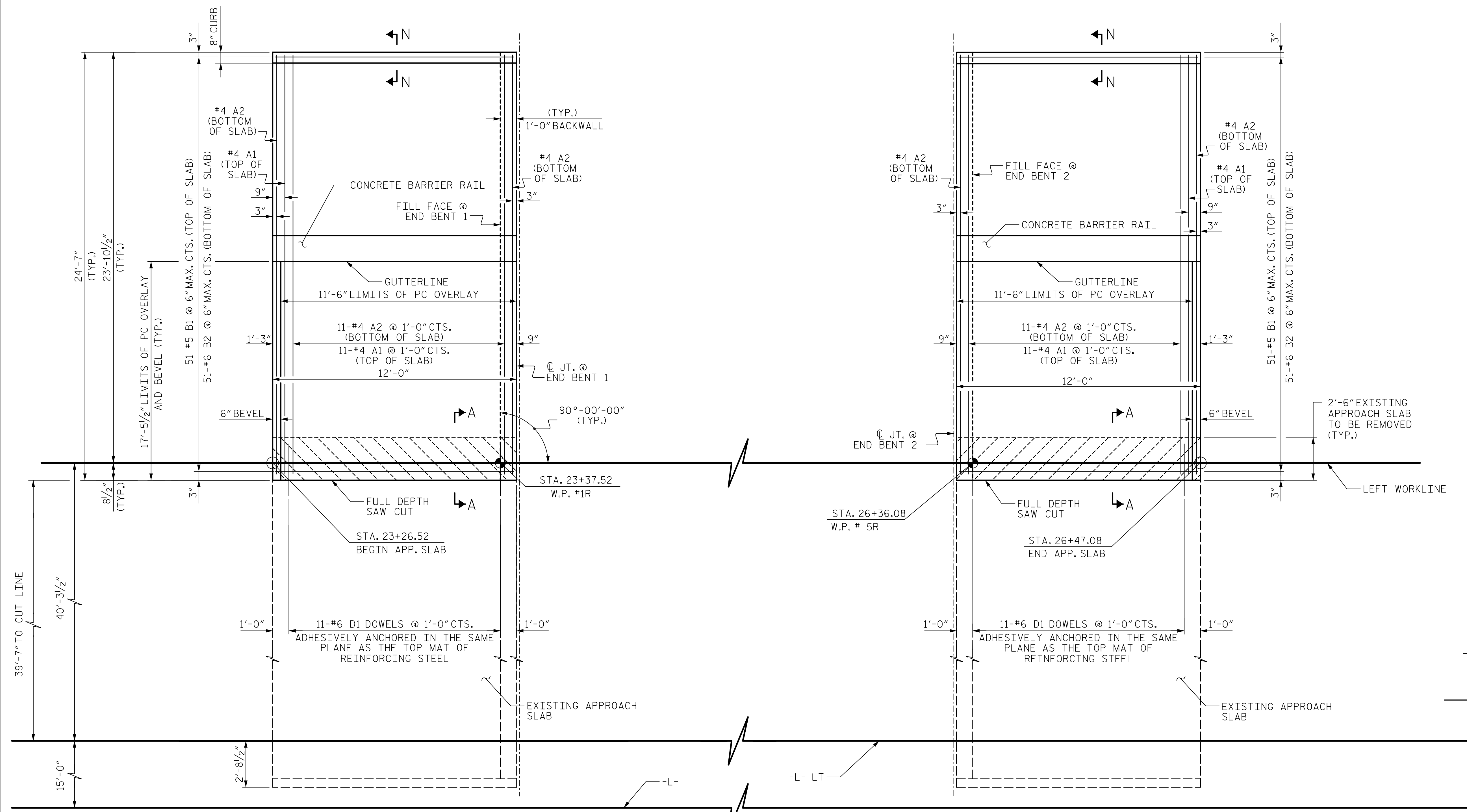

PROJECT NO. U-5748
WAKE COUNTY
STATION: 24+88.00 -L-

SHEET 1 OF 3

AECOM
AECOM TECHNICAL SERVICES OF NC, INC.
5438 WADE PARK BOULEVARD, SUITE 200
RALEIGH, NC 27607
(919) 854-6200
www.aecom.com
AECOM License No. F-0342

JOHN C. MORRISON
NORTH CAROLINA PROFESSIONAL ENGINEER
SEAL 030474
2/10/2023

STATE OF NORTH CAROLINA DEPARTMENT OF TRANSPORTATION RALEIGH					
BRIDGE APPROACH SLAB FOR FLEXIBLE PAVEMENT (SOUTHBOUND LANES)					
REVISIONS					
NO.	BY:	DATE:	NO.	BY:	DATE:
1			3		
2			4		
SHEET NO. S2-50					TOTAL SHEETS 119

DRAWN BY: M. CATER DATE: 08/2021
 CHECKED BY: J.C. MORRISON DATE: 08/2021
 DESIGNED BY: M. CATER DATE: 08/2021
 DESIGN CHECKED BY: J.C. MORRISON DATE: 08/2021

DOCUMENT NOT CONSIDERED
FINAL UNLESS ALL
SIGNATURES COMPLETED