

DATE: 2/9/2023
TIME: 10:27 PM

USER: c:\pcc\...
DRAWN BY: A.R. VAN VUREN
CHECKED BY: J.C. MORRISON
DESIGNED BY: A.R. VAN VUREN
DESIGN CHECKED BY: J.C. MORRISON

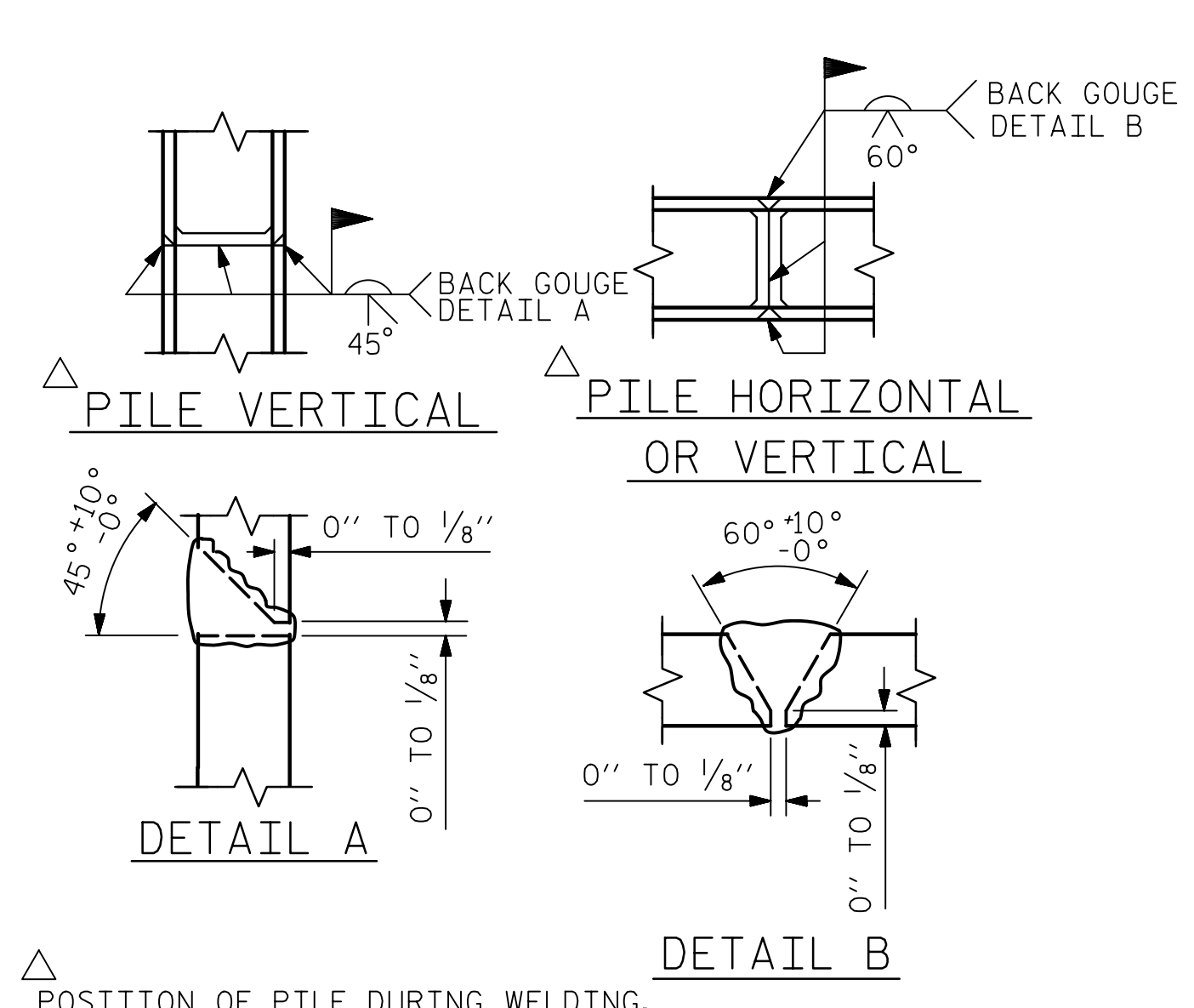

PILE SPLICE DETAILS

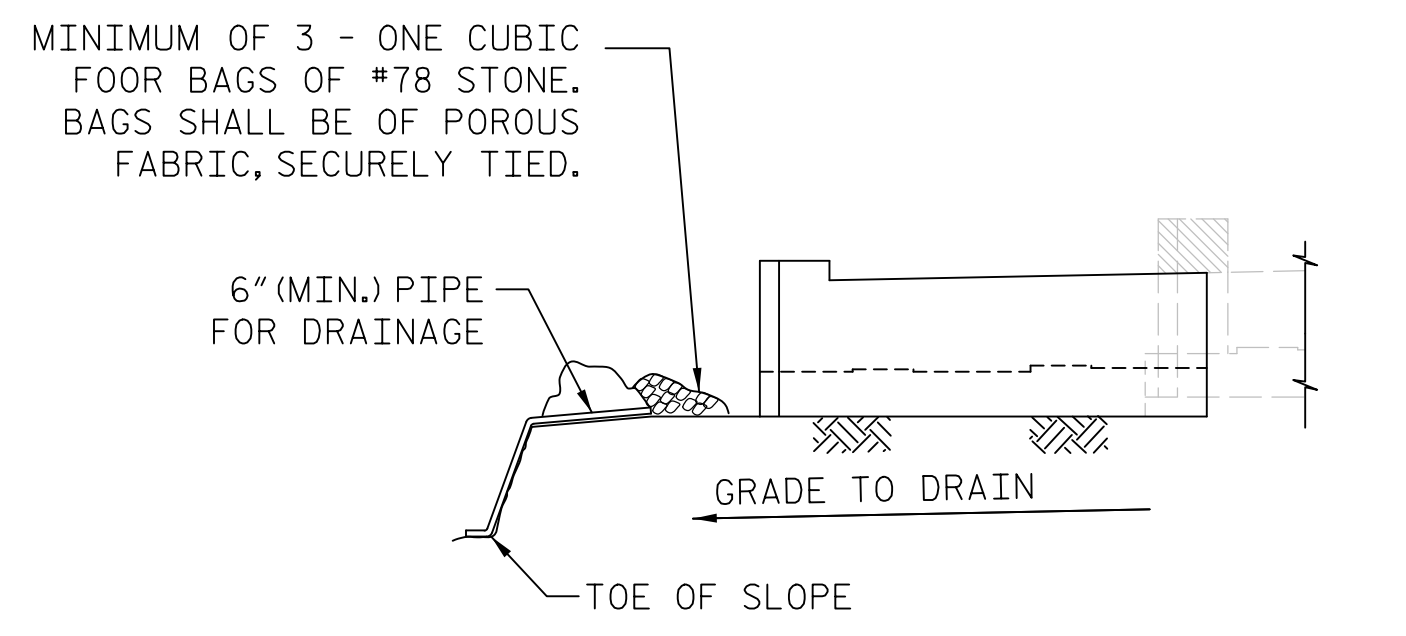

BAGGED STONE AND PIPE SHALL BE PLACED IMMEDIATELY AFTER COMPLETION OF END BENT EXCAVATION. PIPE MAY BE EITHER CONCRETE, CORRUGATED STEEL, CORRUGATED ALUMINUM ALLOY, OR CORRUGATED PLASTIC. PERFORATED PIPE WILL NOT BE ALLOWED.

BAGGED STONE SHALL REMAIN IN PLACE UNTIL THE ENGINEER DIRECTS THAT IT BE REMOVED. THE CONTRACTOR SHALL REMOVE AND DISPOSE OF SILT ACCUMULATIONS AT BAGGED STONE WHEN SO DIRECTED BY THE ENGINEER. BAGS SHALL BE REMOVED AND REPLACED WHENEVER THE ENGINEER DETERMINES THAT THEY HAVE DETERIORATED AND LOST THEIR EFFECTIVENESS.

NO SEPARATE PAYMENT WILL BE MADE FOR THIS WORK AND THE ENTIRE COST OF THIS WORK SHALL BE INCLUDED IN THE UNIT CONTRACT PRICE FOR THE SEVERAL PAY ITEMS.

TEMPORARY DRAINAGE AT END BENT 1

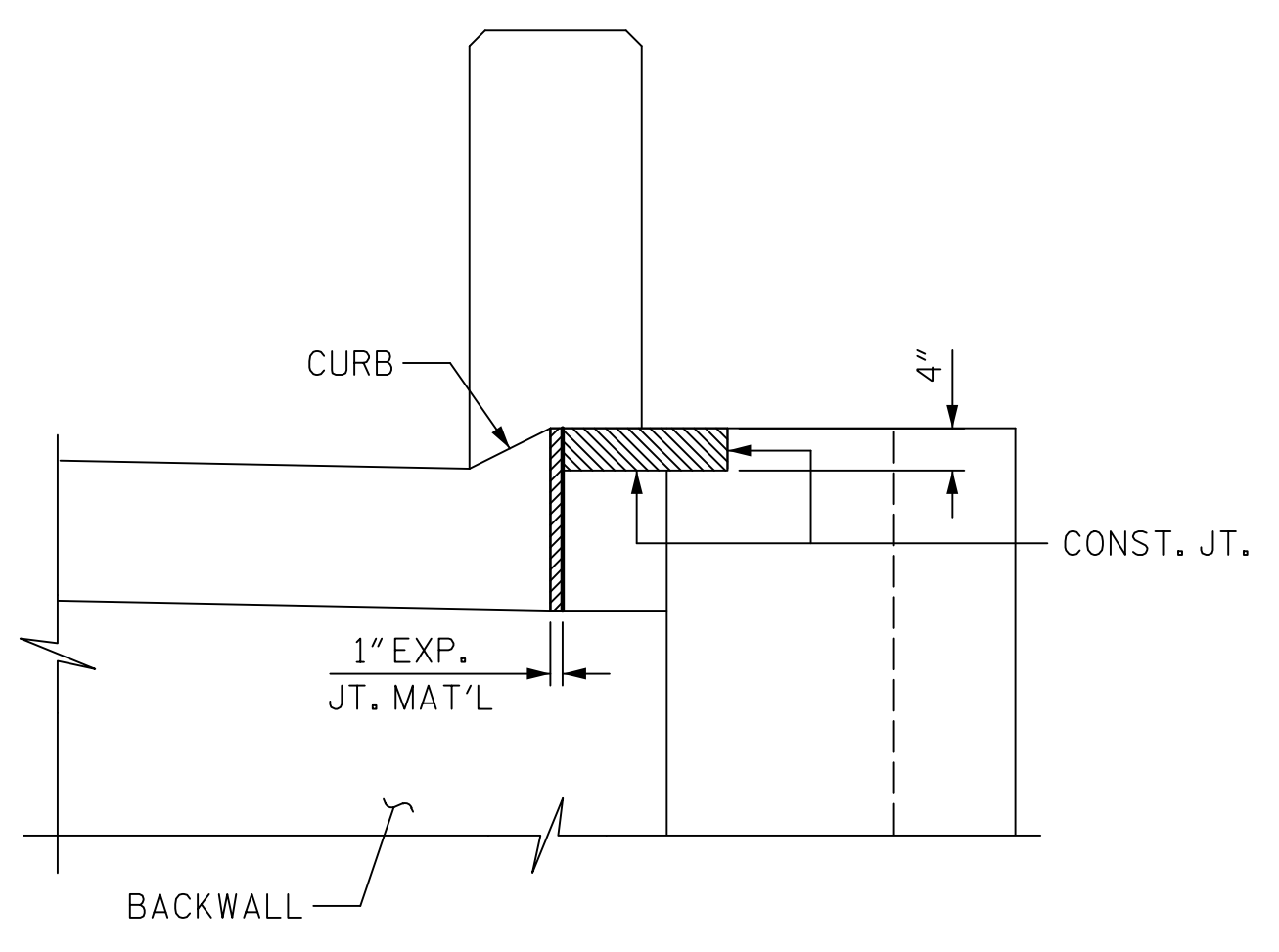
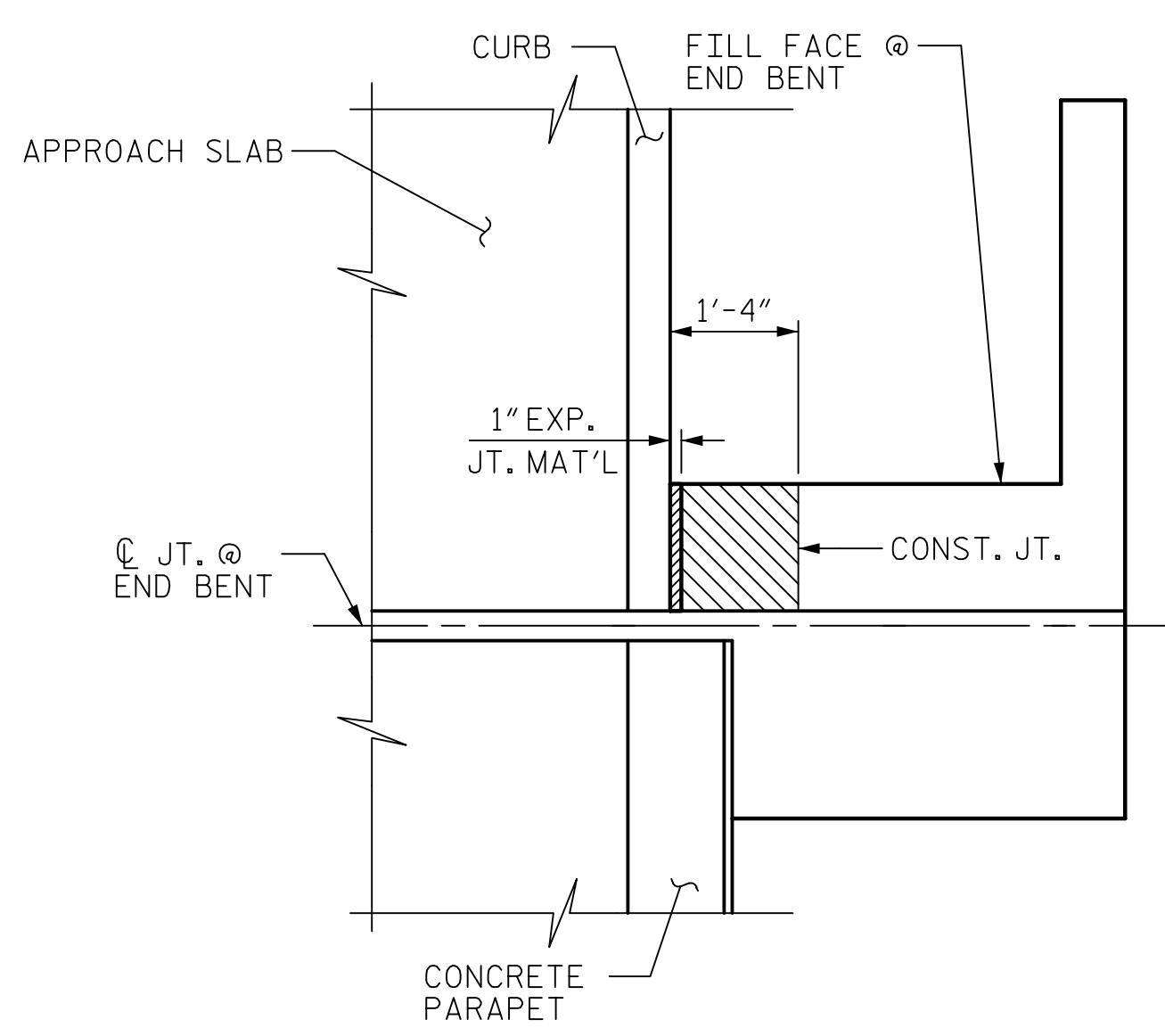

BLOCKOUT IN WINGWALL

NOTES:

- REMOVE EXISTING CAP, BACKWALL AND WINGWALL AS SHOWN AND REPAIR WITH CLASS A CONCRETE OR GROUT FOR STRUCTURES. THE COST OF CLASS A CONCRETE OR GROUT SHALL BE CONSIDERED INCIDENTAL TO THE LUMP SUM COST FOR REMOVAL OF EXISTING STRUCTURE.
- FACE OF EXISTING END BENT CAP AND BACKWALL SHALL BE ROUGHENED TO 1/4" MIN. AMPLITUDE PRIOR TO PLACEMENT OF PROPOSED END BENT CAP OR BACKWALL.
- THE CONTRACTOR SHALL USE AN ADHESIVE ANCHOR SYSTEM FOR THE #9D1 DOWELS AND #4D2 DOWELS. LEVEL 1 FIELD TESTING IS REQUIRED. THE YIELD LOAD FOR #9D1 DOWELS IS 60.0 KIPS. THE YIELD LOAD FOR THE #4D2 DOWELS IS 12.0 KIPS. ADHESIVE ANCHOR SYSTEM SHALL DEVELOP 125% OF THE YIELD LOAD OF THE BAR. FOR ADHESIVELY ANCHORED BOLTS OR DOWELS, SEE SECTION 420-13 OF THE STANDARD SPECIFICATIONS.
- STIRRUPS AND U1 BARS IN CAP MAY BE SHIFTED AS NECESSARY TO CLEAR ANCHOR BOLTS.
- #5 V1 BARS IN BACKWALL SHALL BE PLACED 2" CLEAR FROM TOP OF BACKWALL.
- BACKWALL SHALL BE PLACED BEFORE APPLYING THE EPOXY PROTECTIVE COATING.
- THE TOP SURFACE OF THE END BENT CAP, EXCEPT THE BRIDGE SEAT BUILDUPS, SHALL BE SLOPED TRANSVERSELY FROM THE FILL FACE TO THE FRONT FACE AT THE RATE OF 2%.
- THE TOP SURFACE AREAS OF THE END CAP SHALL BE CURED IN ACCORDANCE WITH THE STANDARD, EXCEPT THE MEMBRANE CURING COMPOUND METHOD SHALL NOT BE USED.
- THE CONCRETE IN THE SHADED AREA OF THE WINGWALL SHALL BE POURED AFTER THE JOINT BETWEEN THE DECK AND THE APPROACH SLAB HAS BEEN SAWED AND PARAPET IS CAST IF SLIP FORMING IS USED.
- FOR WING DETAILS, SEE SHEET 2 OF 3.

DRAWN BY : A.R. VAN VUREN	DATE : 12/2022
CHECKED BY : J.C. MORRISON	DATE : 12/2022
DESIGNED BY : A.R. VAN VUREN	DATE : 12/2022
DESIGN CHECKED BY : J.C. MORRISON	DATE : 12/2022

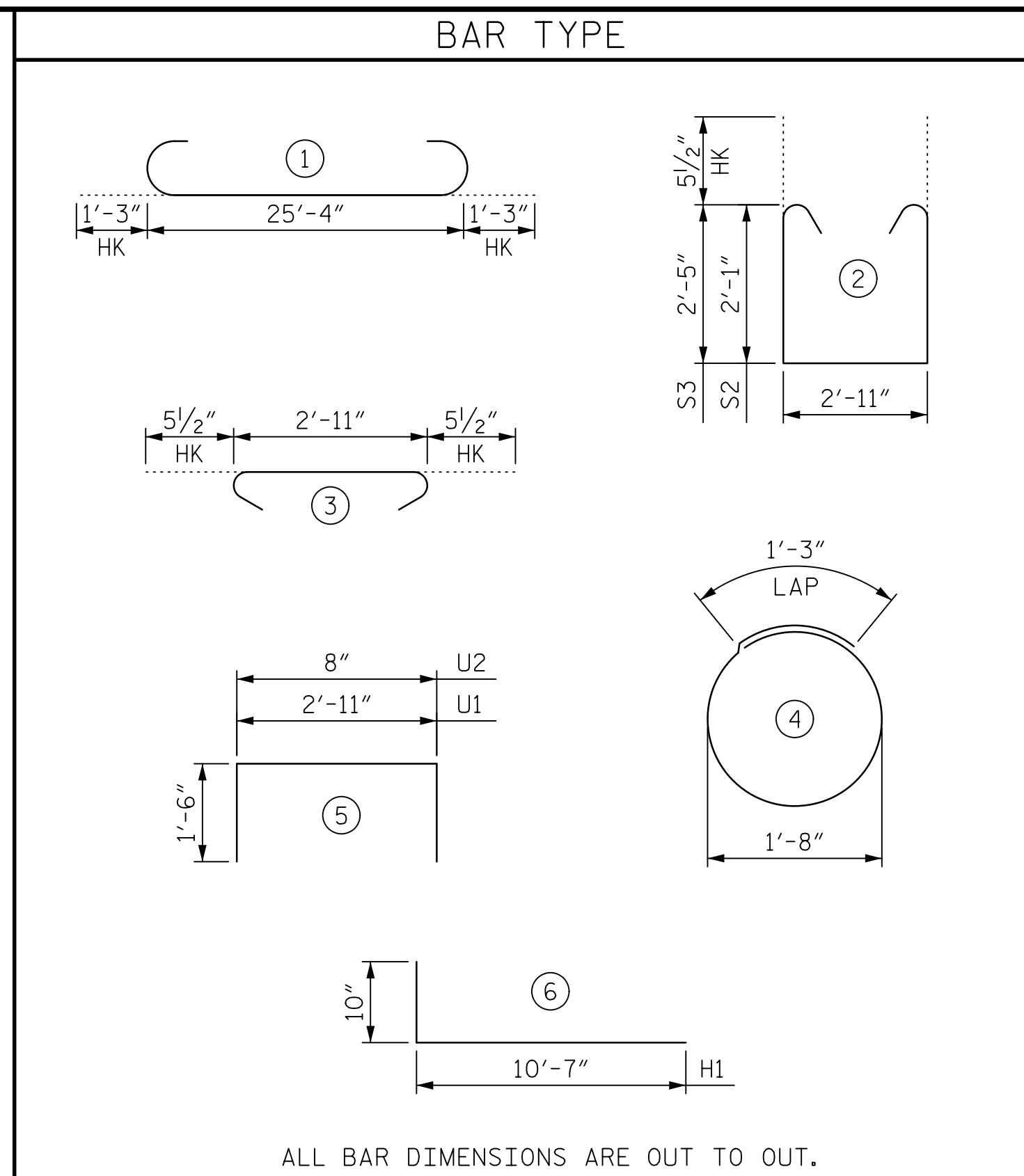

BILL OF MATERIAL					
END BENT 1					
BAR	NO.	SIZE	TYPE	LENGTH	WEIGHT
B1	9	#9	1	27'-11"	854
B2	4	#5	STR	25'-5"	106
B3	4	#4	STR	25'-5"	68
B4	5	#4	STR	3'-4"	11
B5	5	#4	STR	4'-8"	16
B6	7	#4	STR	2'-11"	14
D1	4	#9	STR	7'-6"	102
D2	4	#4	STR	3'-0"	8
H1	24	#5	6	11'-5"	286
K1	12	#4	STR	25'-9"	206
K2	4	#4	STR	3'-3"	9
S1	29	#4	3	3'-10"	74
S2	24	#4	2	8'-0"	128
S3	5	#4	2	8'-10"	30
S4	10	#4	4	6'-6"	43
U1	6	#4	5	5'-11"	24
U2	22	#4	5	3'-8"	54
V1	44	#5	STR	6'-8"	306
V2	30	#4	STR	8'-2"	164
REINFORCING STEEL					2,520 LBS.
CLASS A CONCRETE					
POUR #1 (CAP, COLLARS & LOWER WINGWALLS)					9.2 C.Y.
POUR #2 (BACKWALL & UPPER WINGWALL)					6.9 C.Y.
TOTAL =					16.1 C.Y.

PROJECT NO. U-5748
WAKE COUNTY
 STATION: 24+88.00 -L-

SHEET 3 OF 3

AECOM
AECOM TECHNICAL SERVICES OF NC, INC.
 5438 WADE PARK BOULEVARD, SUITE 200
 RALEIGH, NC 27607
 (919) 854-6200 www.aecom.com
 AECOM License No. F-0342

JOHN C. MORRISON
 NORTH CAROLINA PROFESSIONAL ENGINEER
 SEAL 030474

DocuSigned By: John C. Morrison 2/10/2023

STATE OF NORTH CAROLINA
DEPARTMENT OF TRANSPORTATION
 RALEIGH

SUBSTRUCTURE
END BENT 1
(SOUTHBOUND LANES)

REVISIONS					
NO.	BY:	DATE:	NO.	BY:	DATE:
1			3		
2			4		

SHEET NO. **S2-38**
 TOTAL SHEETS **119**

DOCUMENT NOT CONSIDERED FINAL UNLESS ALL SIGNATURES COMPLETED