

NAD 83 / N.A. 2011

**NOTE:** PLACE TEMPORARY ROCK SEDIMENT DAMS TYPE - B AND TEMPORARY ROCK SILT CHECKS TYPE - A AT DRAINAGE OUTLETS.

**CLEARING AND GRUBBING EROSION CONTROL FOR CONSTRUCTION SHEET 8**

**NOTE:** UTILIZE FABRIC INSERT INLET PROTECTION DEVICES IN LIEU OF ROCK INLET SEDIMENT TRAPS TYPE C IN AREAS WHERE WATER MAY POND ON ROAD OPEN TO LIVE TRAFFIC.

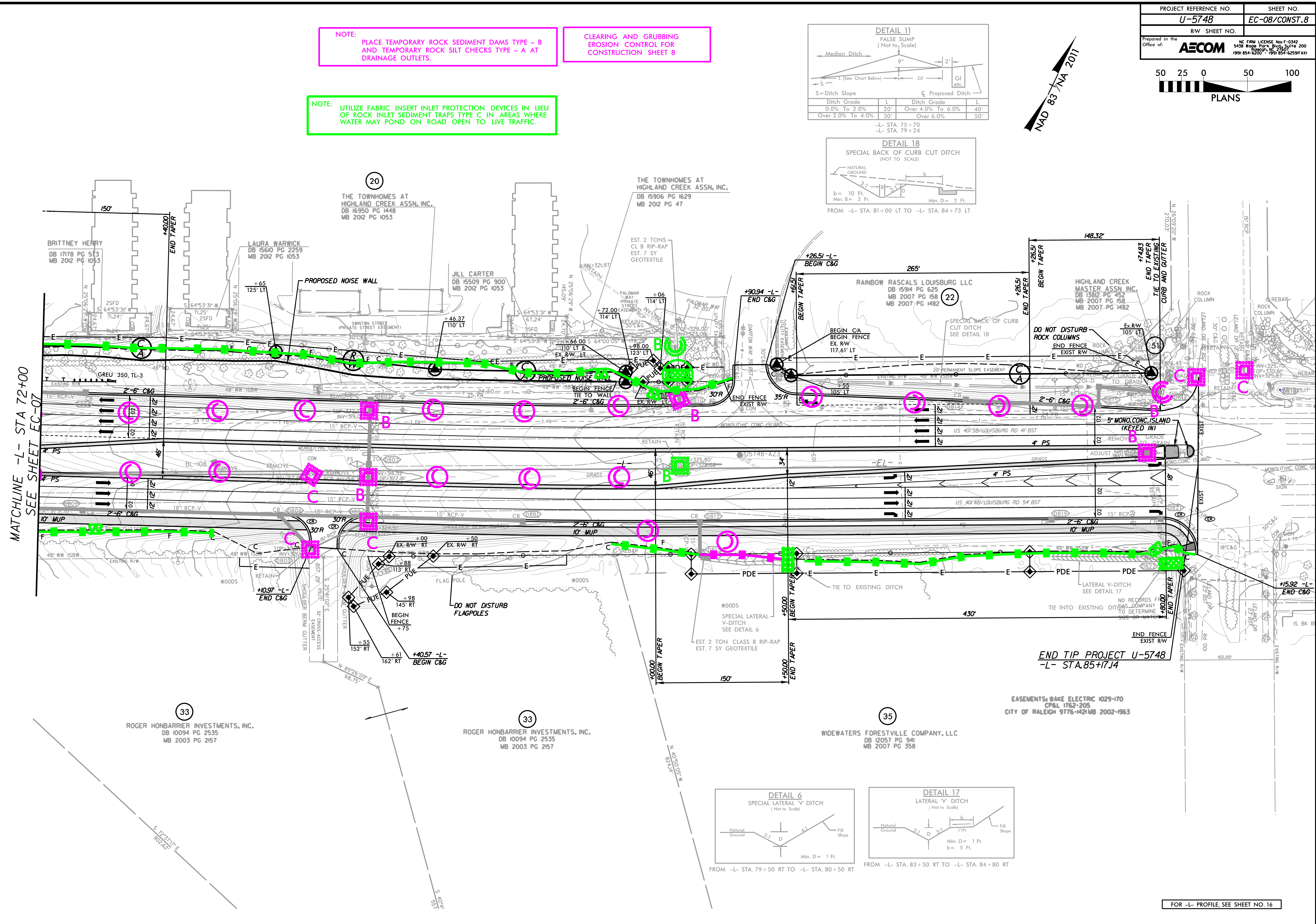
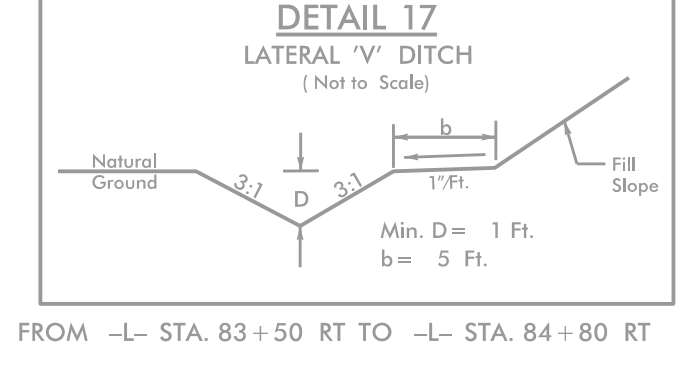
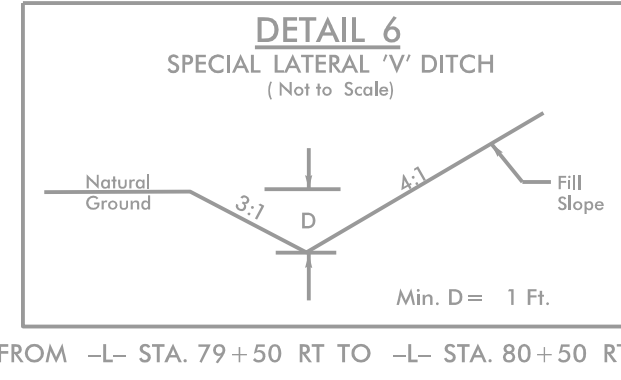
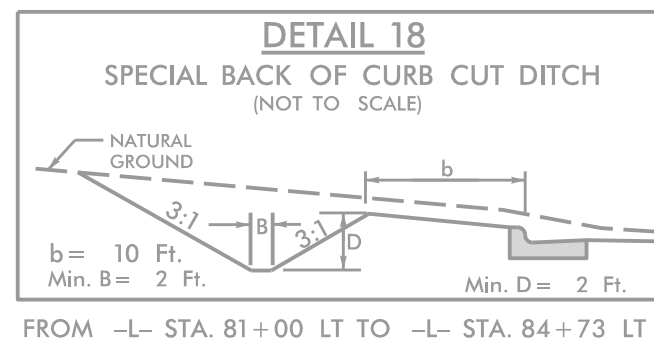
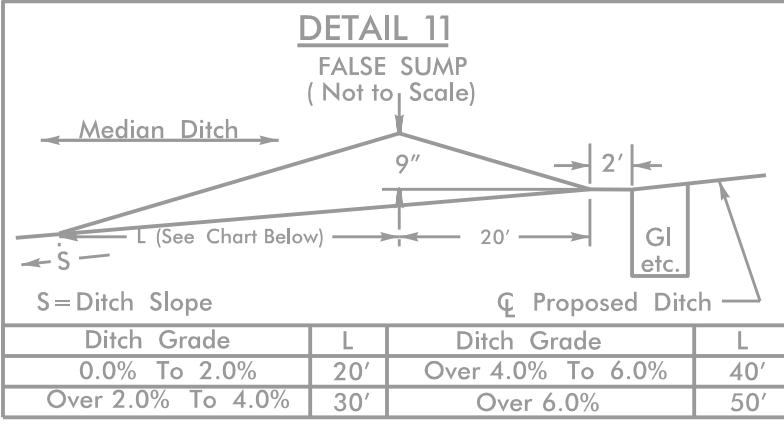

MATCHLINE -L- STA 72+00  
SEE SHEET EC-07

END TIP PROJECT U-5748  
-L- STA. 85+74

EASEMENTS: WAKE ELECTRIC 1029-170  
CP&L 1762-205  
CITY OF RALEIGH 9776-1421 MB 2002-1963

5/14/2011 9:50:33 AM  
 \\60609754-11116-Ligon Mill\900-CAD\_GIS\910-CAD\70-NC001\_TIP\Environmental\Design\U5748\_EC\_psh08\_CG.dgn