

ENVIRONMENTALLY SENSITIVE AREA
SEE PROJECT SPECIAL PROVISIONS

NOTE: UTILIZE FABRIC INSERT INLET PROTECTION DEVICES IN LIEU OF ROCK INLET SEDIMENT TRAPS TYPE C IN AREAS WHERE WATER MAY POND ON ROAD OPEN TO LIVE TRAFFIC.

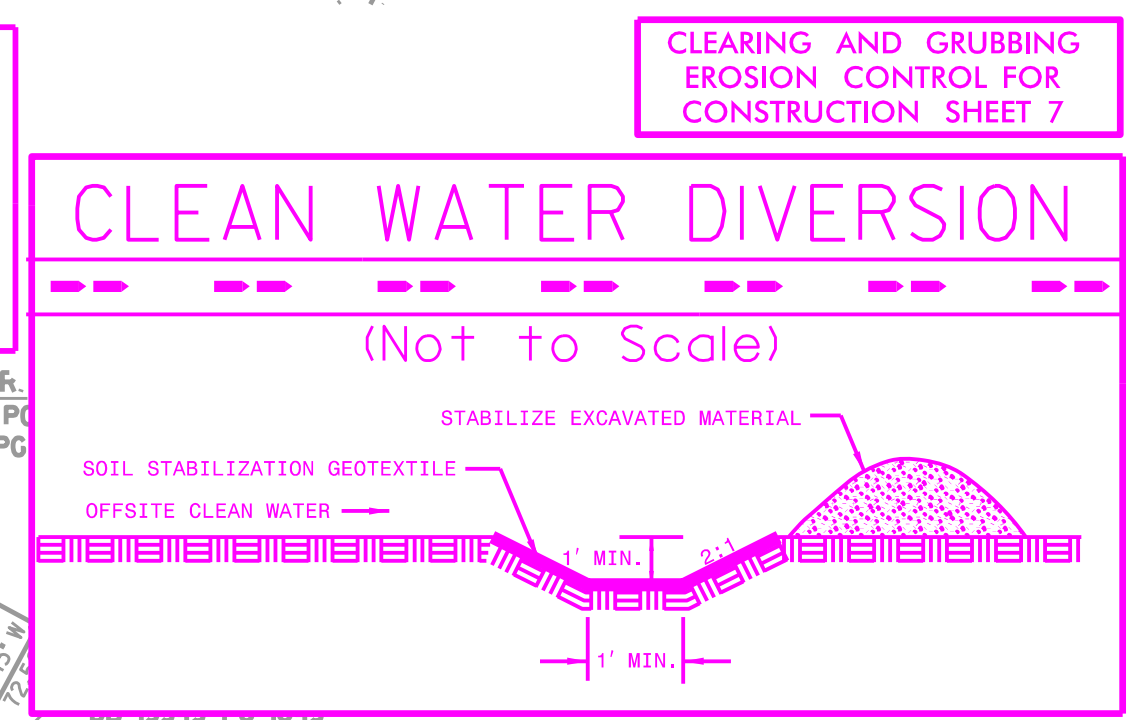

28' x 16' x 3
1.5 inch Skimmer
with 0.625 inch
Orifice Diameter
4 ft. weir
(See Tiered Skimmer
Basin Detail)
ID 7.1

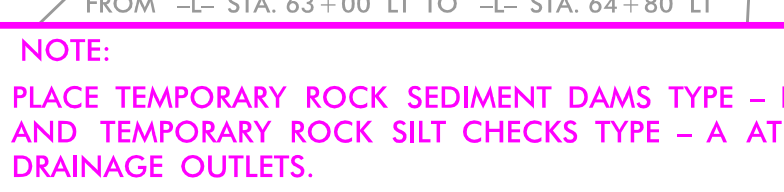

NOTE: PLACE TEMPORARY ROCK SEDIMENT DAMS TYPE - B AND TEMPORARY ROCK SILT CHECKS TYPE - A AT DRAINAGE OUTLETS.

Modified Silt Basin
Type 'B'
28' x 16' x 3'
4 ft. weir
(See Tiered Skimmer
Basin Detail)
ID 7.1

5/14/2019
\\60609754-115248-PW-Ligon-M111-900-CAD-GIS-910-CAD-11-ENVIRONMENTAL\Design\U5748-EC-psh07-CG.dgn

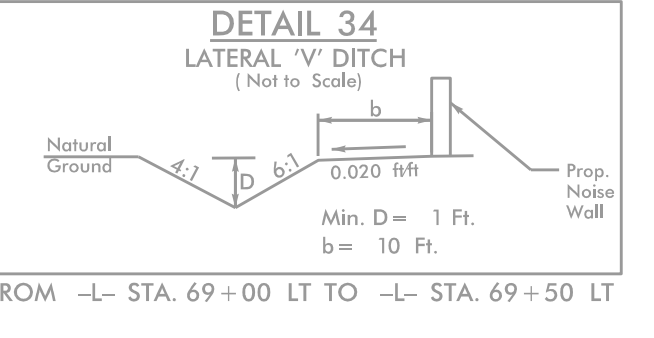
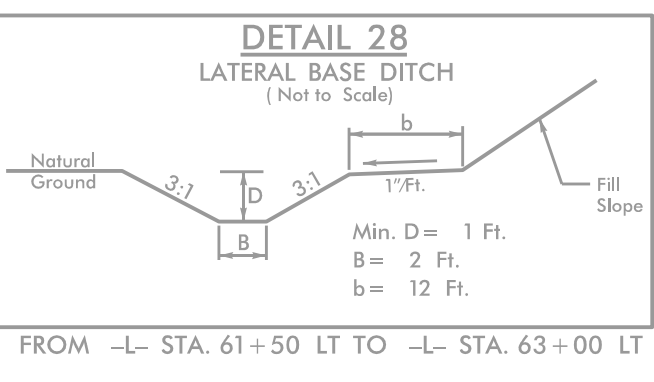
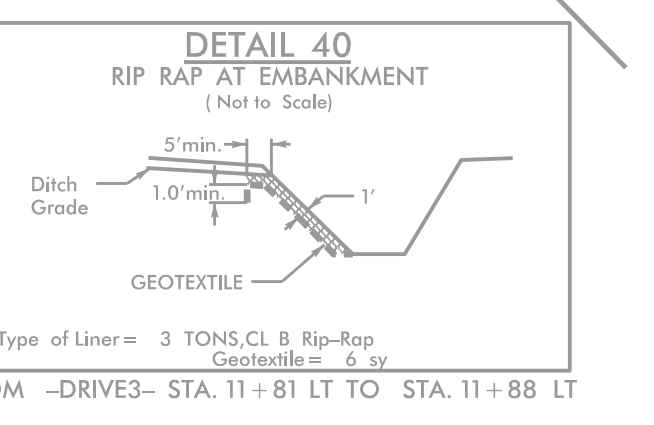
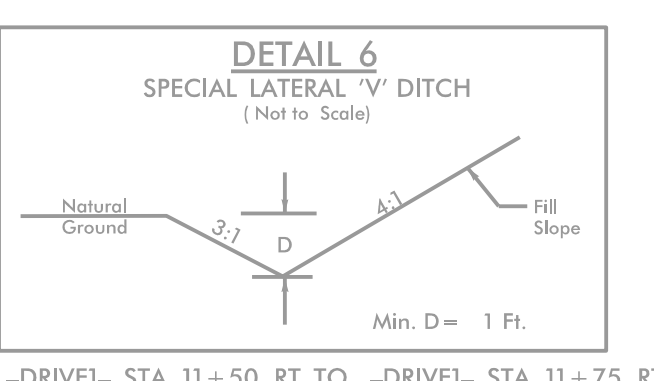
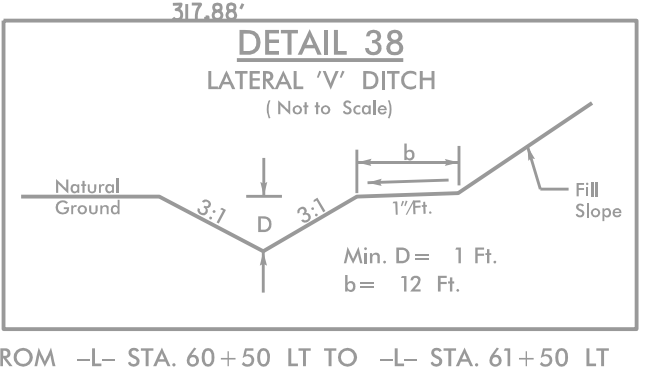
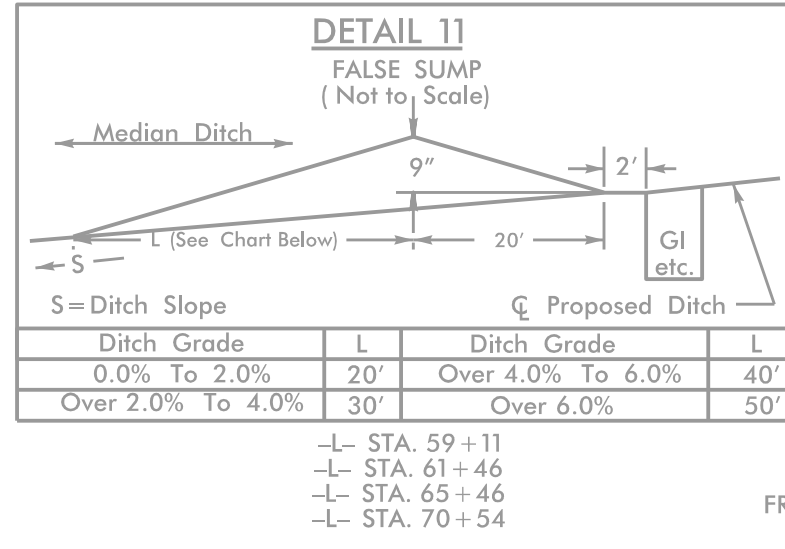
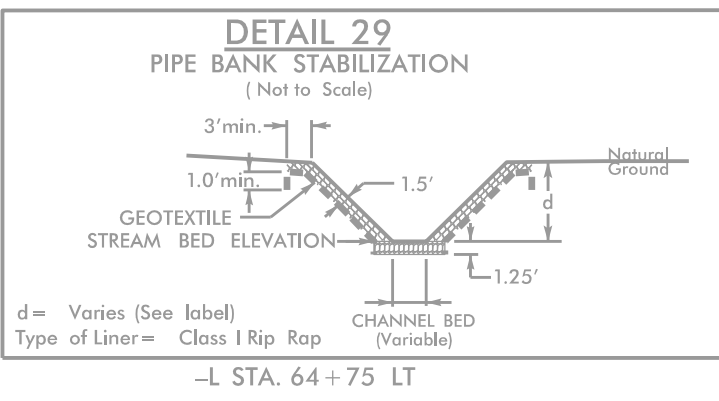
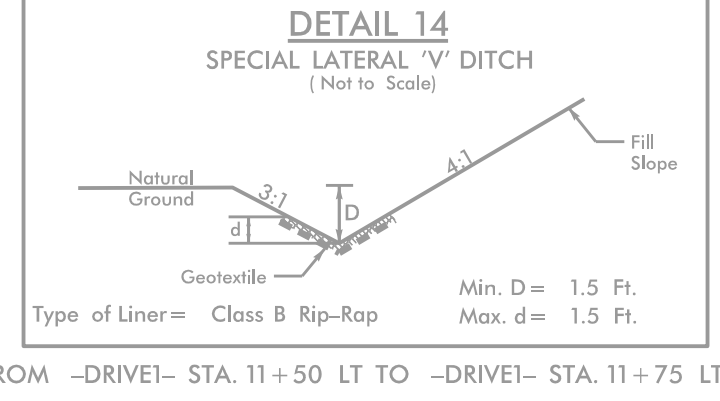
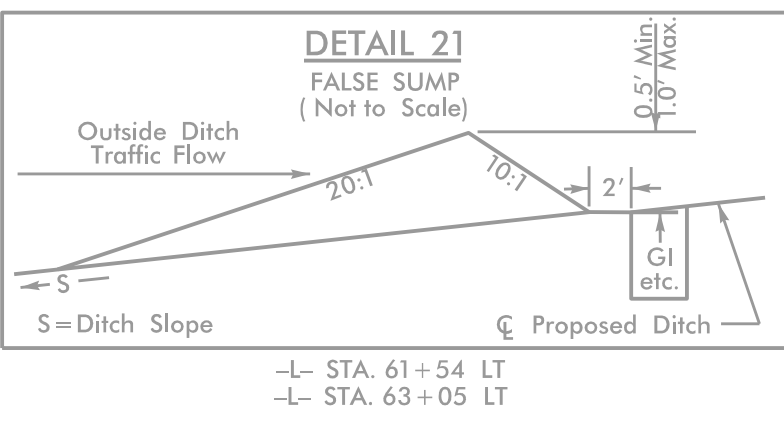
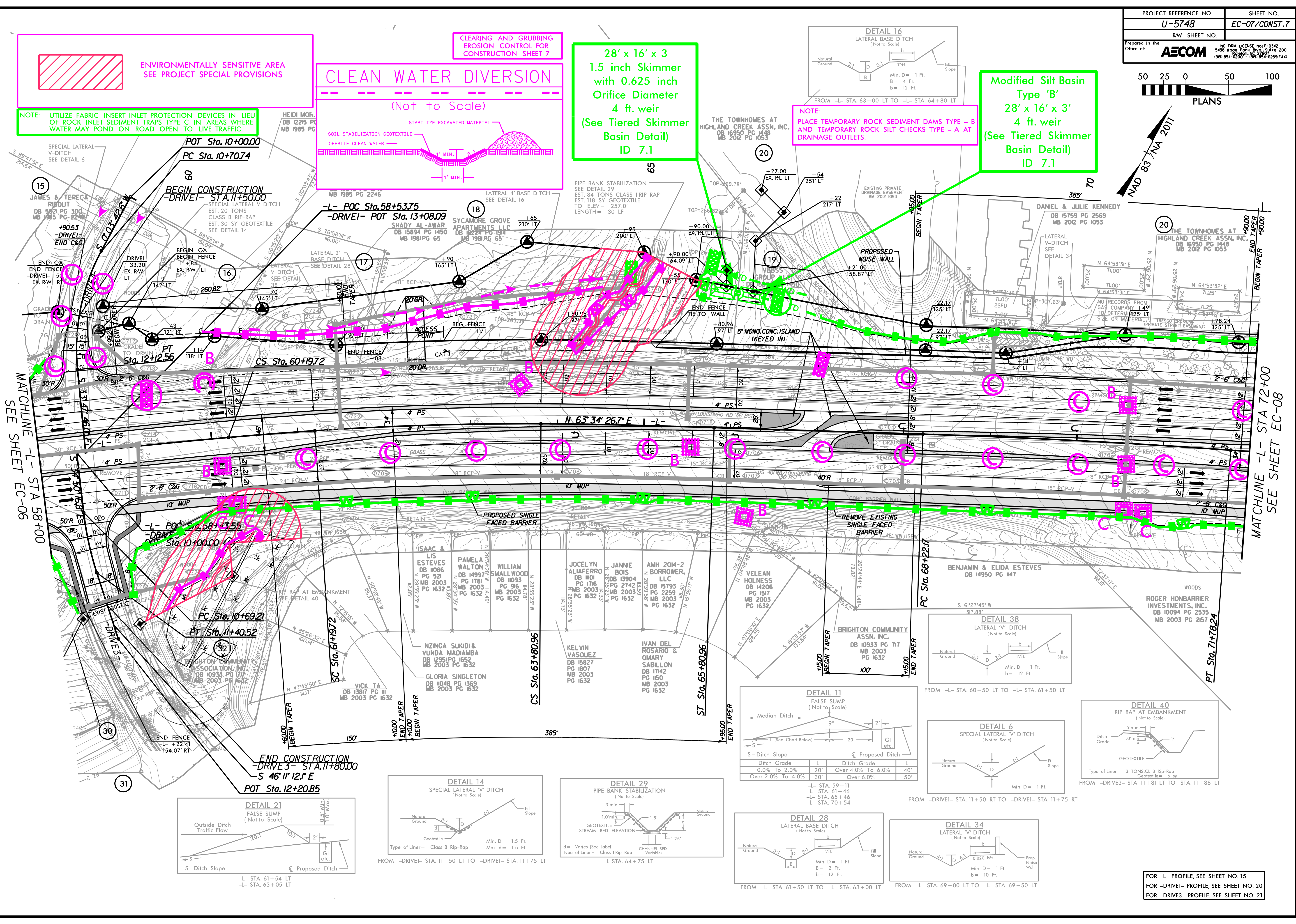

FOR -L- PROFILE, SEE SHEET NO. 15
FOR -DRIVE1- PROFILE, SEE SHEET NO. 20
FOR -DRIVE3- PROFILE, SEE SHEET NO. 21