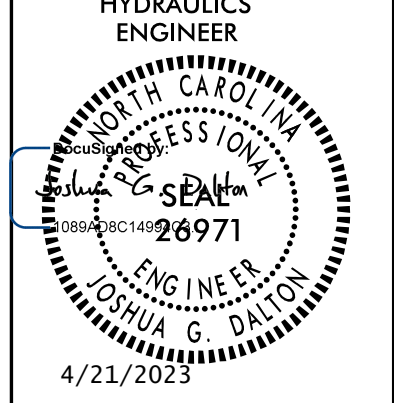

5/28/24

-Y42RPB-

SUNGATE DESIGN GROUP, P.A.
 905 JONES FRANKLIN ROAD
 RALEIGH, NORTH CAROLINA 27606
 TEL (919) 859-2243
 ENG FIRM LICENSE NO. C-890

Stantec
 Stantec Consulting Services Inc.
 801 Jones Franklin Road
 Suite 300
 Raleigh, NC 27606
 Tel. (919) 851-6866
 Fax. (919) 851-7024
 www.stantec.com
 License No. F-0672

PROJECT REFERENCE NO.	SHEET NO.
R-2707E	28
ROADWAY DESIGN ENGINEER	HYDRAULICS ENGINEER
 MATTHEW S. FERGUSON ENGINEER 4/21/2023	 JONATHAN G. DALTON ENGINEER 4/21/2023

PI = 20+00.00
 EL = 784.50'
 VC = 300'
 K = 158
 DS = 65 MPH

PI = 13+50.00
 EL = 772.18'
 VC = 590'
 K = 151
 DS = 60 MPH

BEGIN GRADE
 -Y42RPB- STA 10+00.00=
 -L WB- STA 876+63.42
 (47' LT) ELEV 751.91'

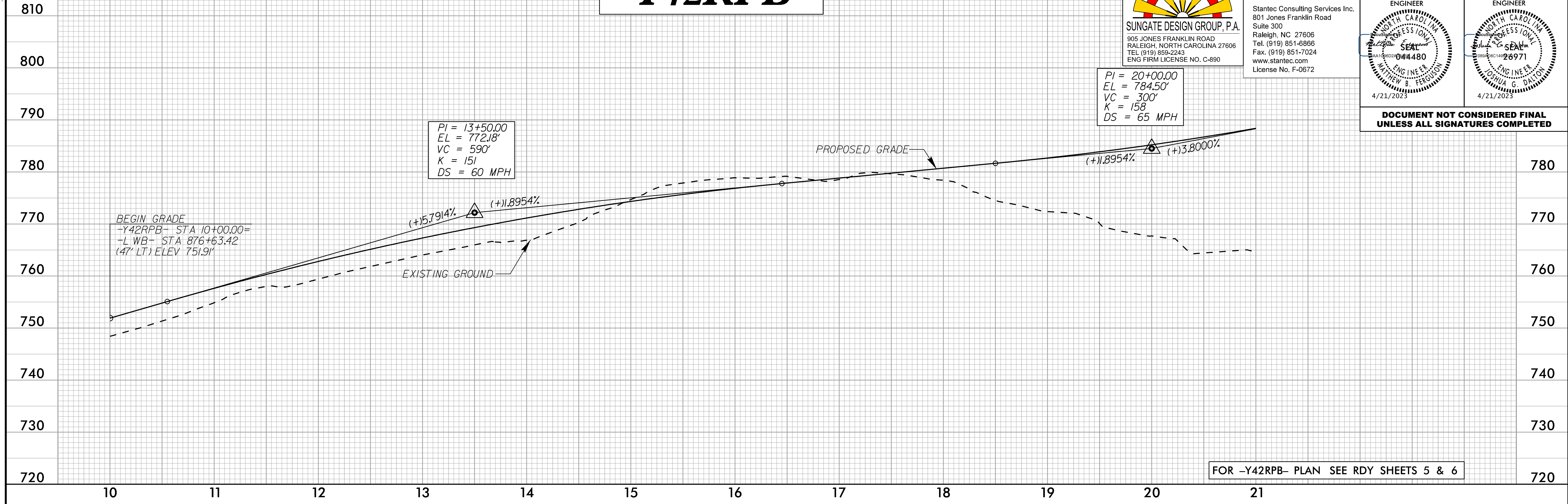

FOR -Y42RPB- PLAN SEE RDY SHEETS 5 & 6

-Y42RPB-

PI = 24+00.00
 EL = 799.70'
 VC = 300'
 K = 174
 DS = 60 MPH

END GRADE
 -Y42RPB- STA 25+75.11=
 -RABT2- STA 12+40.76
 (20' RT) ELEV = 803.33'

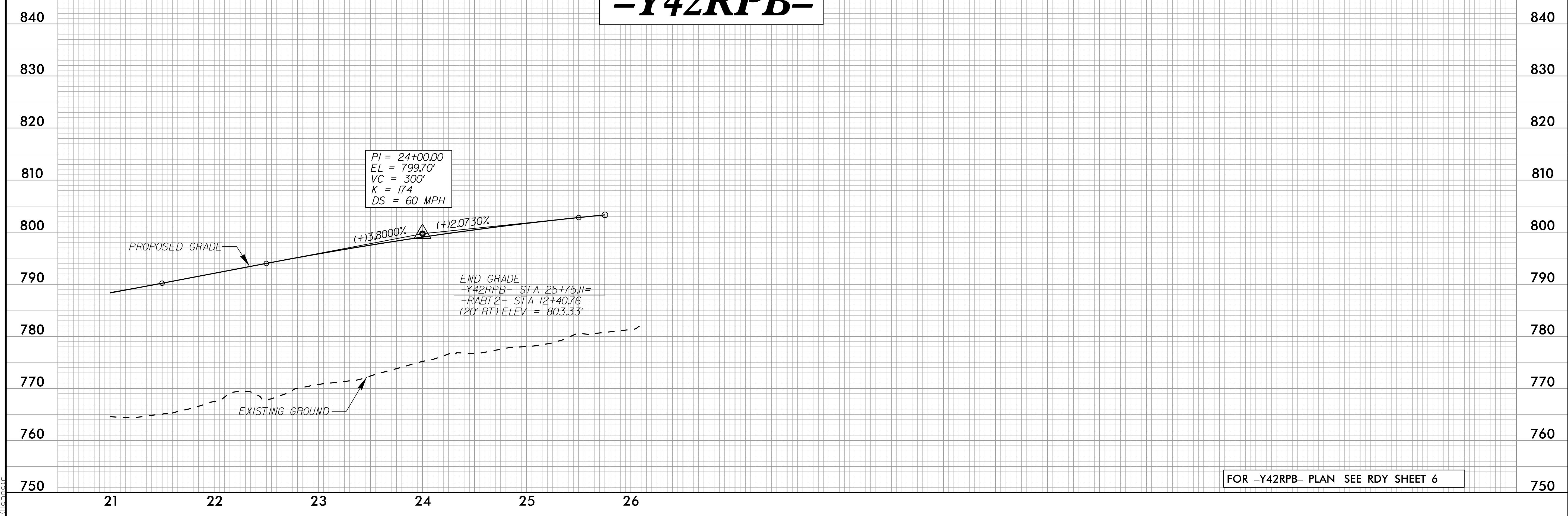

FOR -Y42RPB- PLAN SEE RDY SHEET 6

3/30/2023
 3/1/2024
 3/28/2024
 R:\mg\dms43\24\R2707E_RDY_PFL_PSH.dgn
 P:\dms43