

SUNGATE DESIGN GROUP, P.A.
 905 JONES FRANKLIN ROAD
 RALEIGH, NORTH CAROLINA 27606
 TEL (919) 859-2243
 ENG FIRM LICENSE NO. C-890

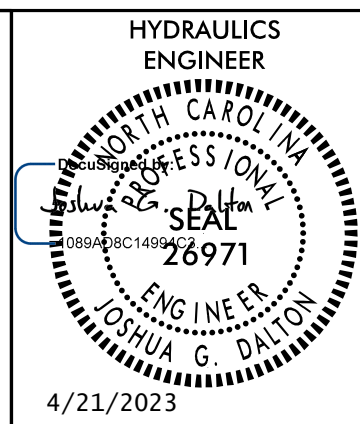

PROJECT REFERENCE NO. <i>R-2707E</i>	SHEET NO. <i>2D-2</i>
HYDRAULICS ENGINEER	
JOSHUA G. DALTON	
4/21/2023	

**DOCUMENT NOT CONSIDERED FINAL
 UNLESS ALL SIGNATURES COMPLETED**

DETAIL #30
DRY DETENTION BASIN DRAWDOWN STRUCTURE

NOT TO SCALE

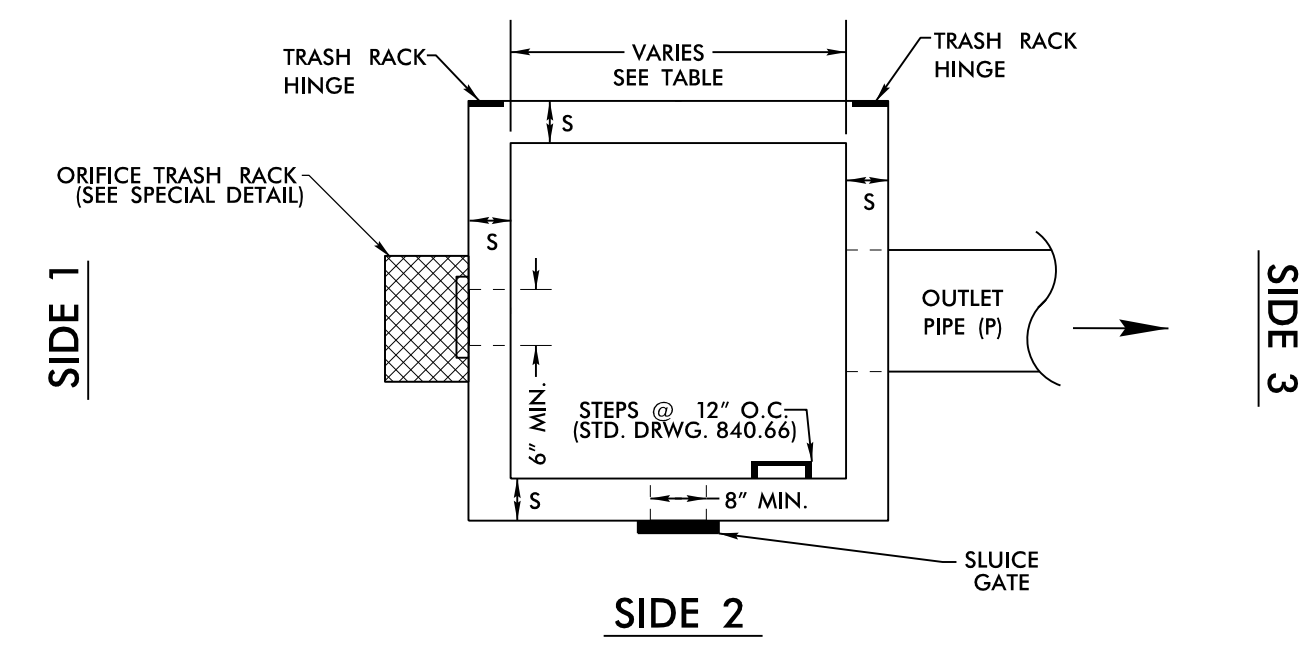
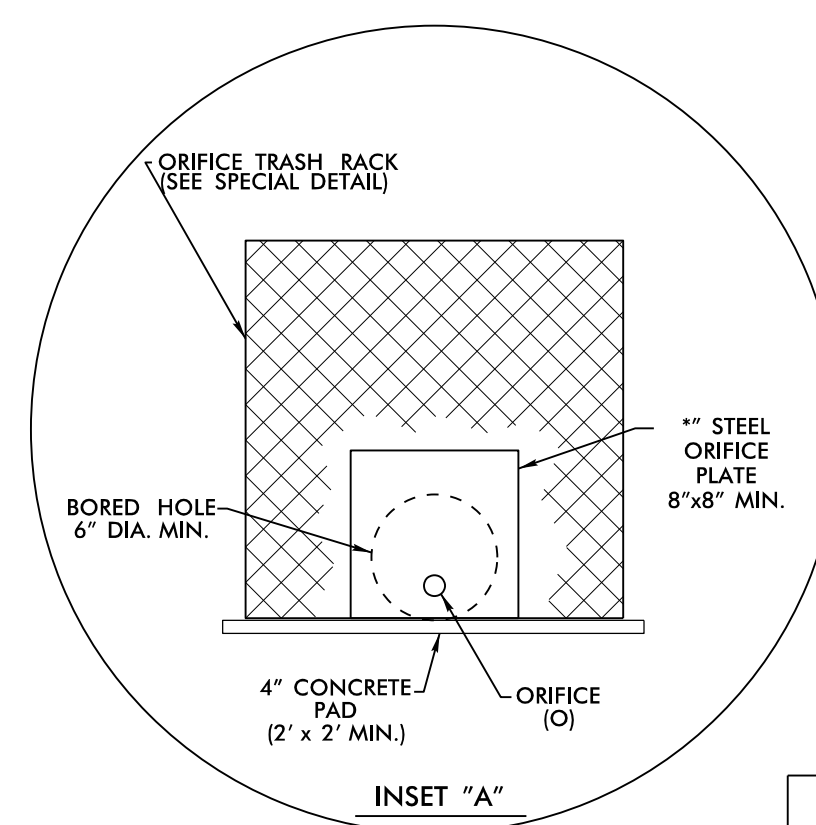
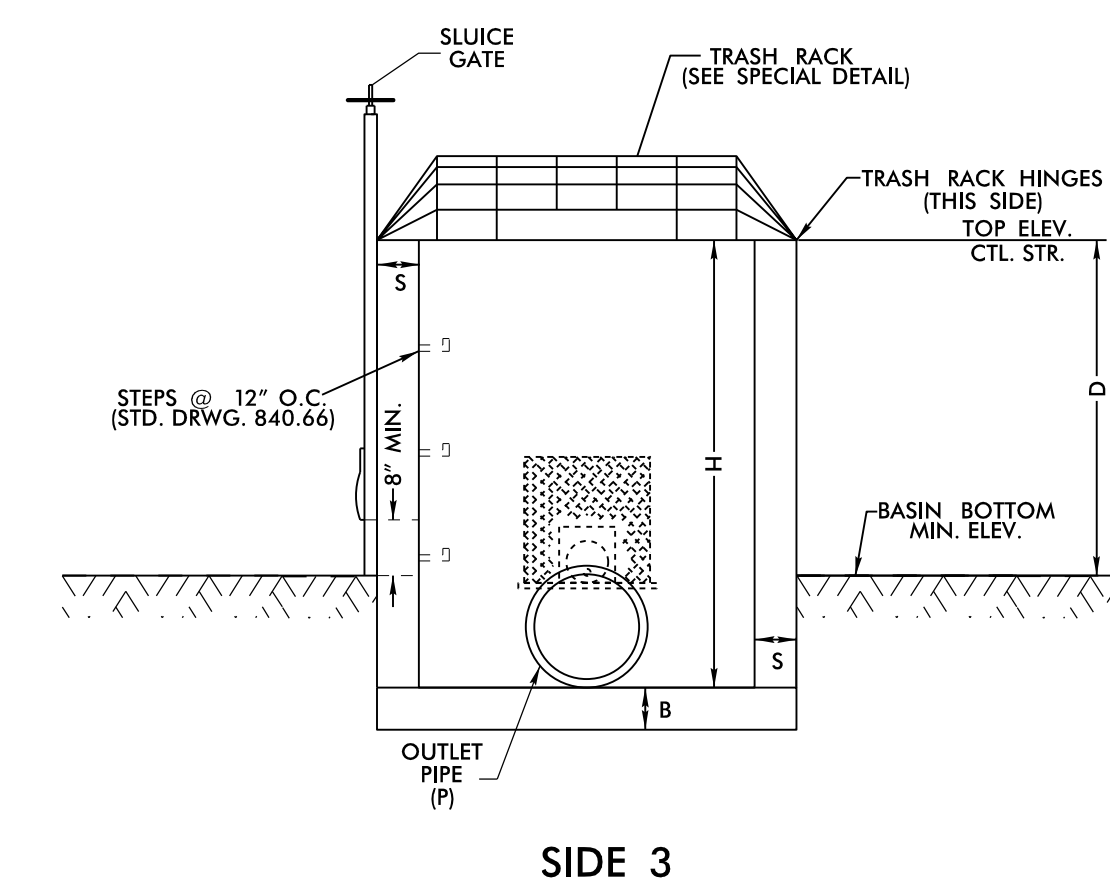
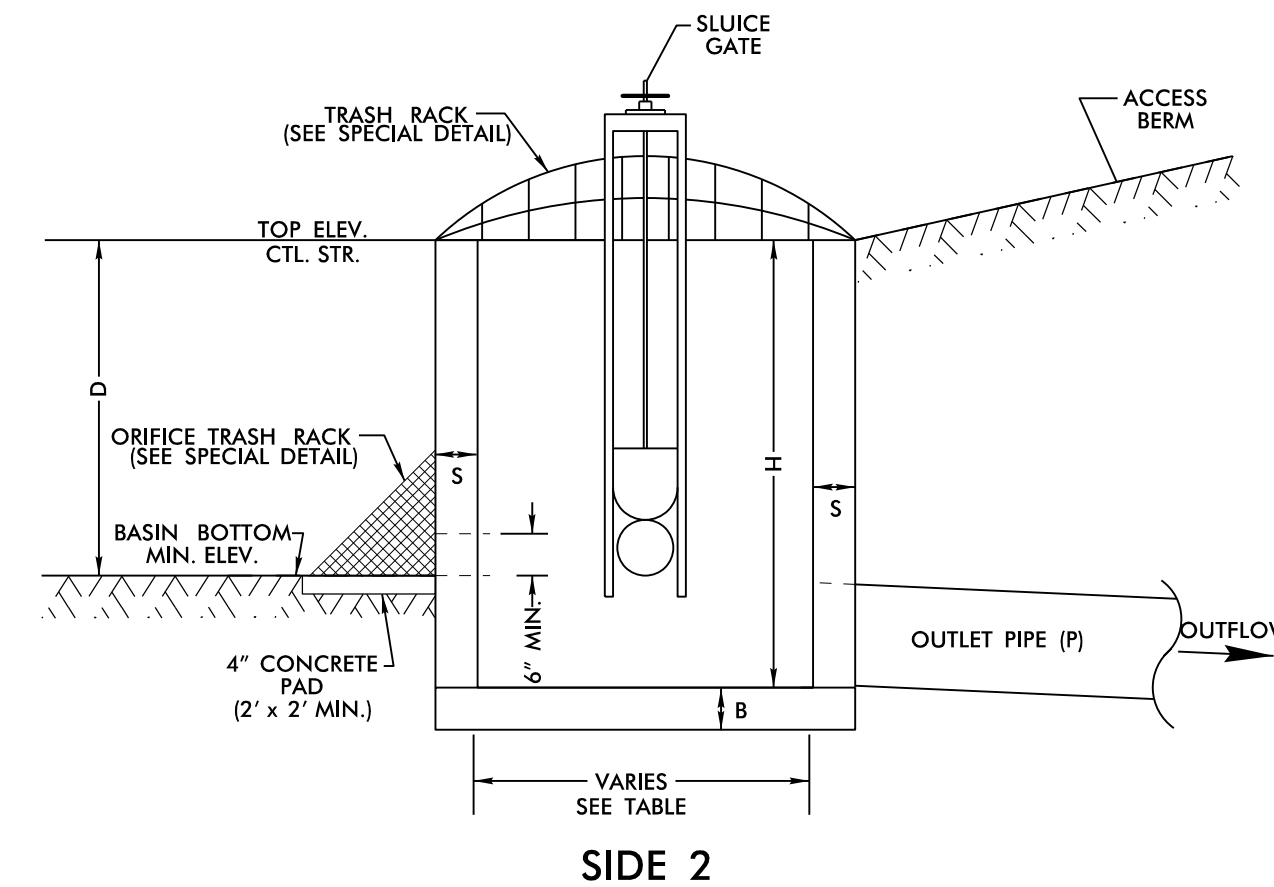
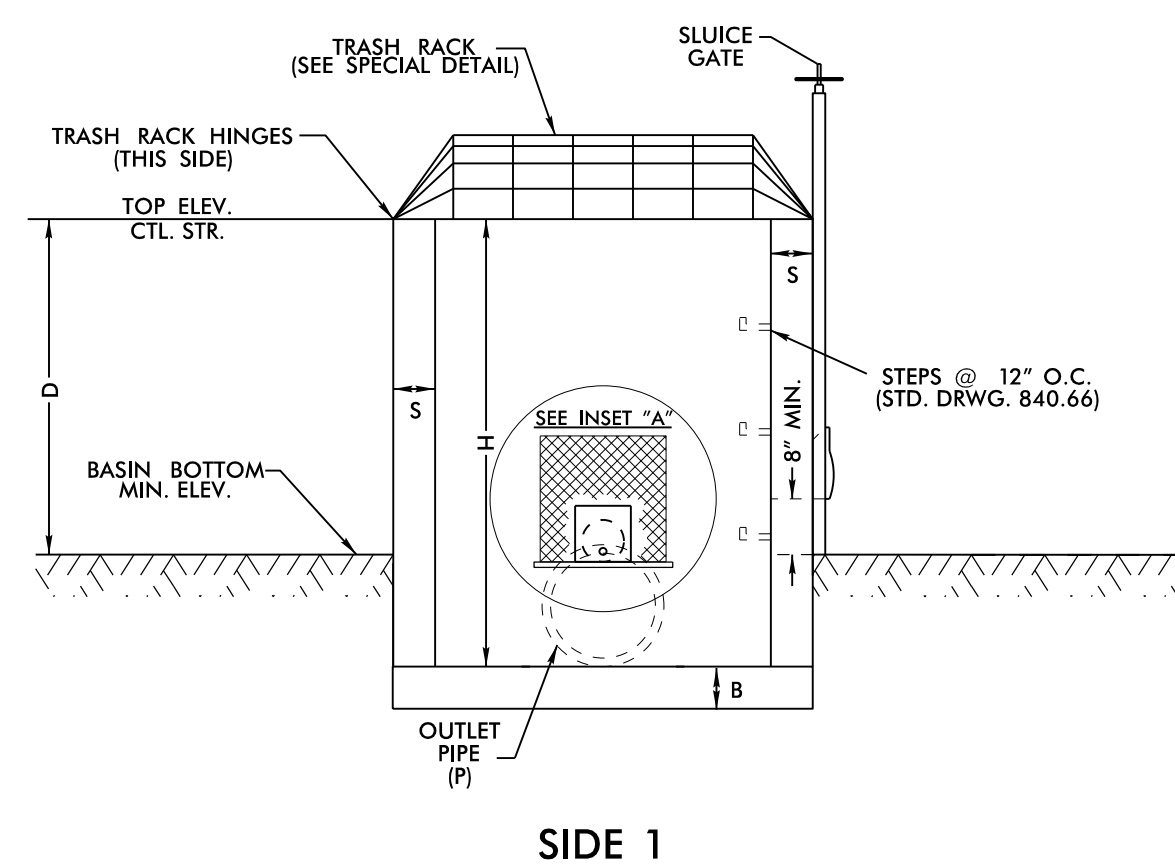

- NOTES:**
1. TOP ELEVATION OF CONTROL STRUCTURE (WEIR ELEVATION) SHOULD BE SET AT THE WQ_v ELEVATION.
 2. 15" MINIMUM DIAMETER FOR OUTLET PIPE.
 3. 2" MINIMUM DIAMETER ORIFICE. IF ORIFICE IS GREATER THAN 6", A STEEL PLATE IS NOT REQUIRED.
 4. NO BEDDING MATERIAL TO BE USED. THEREFORE, DO NOT FOLLOW STANDARD DRAWINGS FOR METHOD OF PIPE INSTALLATION FOR OUTLET PIPE THROUGH EMBANKMENT.
 5. SLUICE GATE IS FOR MAINTENANCE AND SHOULD REMAIN CLOSED DURING NORMAL OPERATION. A GATE VALVE MAY BE USED IN LIEU OF THE 8" SLUICE GATE.
 6. SLUICE GATE SHALL PROVIDE WATERTIGHT SEAL. PROVIDE ADEQUATE CLEARANCE FOR GATE OPERATION AND FOR PROPER SEATING OF GATE OVER PIPE.
 7. SELECT BOX STANDARD AS REQUIRED TO ACCOMMODATE SLUICE GATE AND ORIFICE TRASH RACK WIDTH.
 8. ENSURE TRASH RACK OPENS FREELY AND WITHOUT INTERFERENCE WITH SLUICE GATE.
 9. ADJUST FOOTER DIMENSIONS AS NEEDED FOR ANTI-FLOTATION.
 10. PAYMENT OF TRASH RACKS ARE INCIDENTAL TO BASIN DRAWDOWN STRUCTURE.
 11. PAYMENT OF 4" CONCRETE ORIFICE TRASH RACK PAD INCIDENTAL TO THE BASIN DRAWDOWN STRUCTURE.

MINIMUM DIMENSIONS FOR DRY DETENTION BASIN DRAWDOWN STRUCTURE											
STATION	STRUCTURE NUMBER	S (INCHES) 6" MIN.	B (INCHES) 6" MIN.	BASIN BOTTOM MINIMUM ELEV.	TOP ELEVATION CONTROL STRUCTURE	MAX. STORAGE DEPTH(D) FEET	INV. ELEV. CTL. STR.	CTL. STR. DIMENSIONS (W x L x H)	ORIFICE DIAMETER (O) INCHES	ORIFICE INV. ELEV.	OUTLET PIPE DIAMETER(P) INCHES
896 + 75 -L- RT	0630	6"	18"	772.0	775.0	3.0'	770.0	5.0' X 5.0' X 5.0'	2.0"	772.0	24"
19 + 22 -Y42RPB- LT	0619	6"	18"	764.0	768.0	4.0'	762.0	5.0' X 5.0' X 6.0'	2.0"	724.0	24"
20 + 25 -Y42RPC- RT	0635	6"	18"	773.0	775.0	2.0'	770.0	5.0' X 5.0' X 5.0'	2.0"	773.0	24"