

6/2/2023

SUMMARY OF SHOULDER DRAIN, SHOULDER DRAIN PIPE, & CONCRETE OULET PADS

STATION	STATION	LOCATION	OUTLET LOCATION	SHOULDER DRAIN PIPE (FT)	SHOULDER DRAIN (FT)	OUTLET PIPE (FT)	CONCRETE PAD	REMARKS			
851+15.00	865+00.00	LT. OUTSIDE	851+15	1385.00	1385.00	N/A		TIE TO 2GI 403			
			852+00			N/A		TIE TO 2GI 402			
			853+00			N/A		TIE TO 2GI 401			
			856+00			19	1				
			859+00					11			
			862+00					N/A	TIE TO 2GI 417		
887+20.79	902+00.00	LT. OUTSIDE	862+65			N/A		TIE TO 2GI 418			
			887+20.79	1479.21	1479.21	18	1				
			891+75			20			TIE TO 2GI 614		
			893+00			20			TIE TO 2GI 607		
			896+00			25	1				
			900+00			16	1				
902+15.00	906+00.00	LT. OUTSIDE	902+15	385.00	385.00	N/A		TIE TO 2GI 652			
			904+05			N/A			TIE TO 2GI 651		
926+50.00	931+66.49	LT. OUTSIDE	926+50	516.49	516.49	5		TIE TO 2GI 826			
			929+00			33	1				
943+18.69	955+00.00	LT. OUTSIDE	943+18.69	1181.31	1181.31	11	1				
			946+00			11	1				
			952+00			22	1				
			955+00			18	1				
851+15.00	852+85.00	RT. OUTSIDE	851+15	170.00	170.00	N/A		TIE TO 2GI 412			
			851+30			N/A			TIE TO 2GI 411		
			852+00			20			TIE TO 2GI 413		
881+50.00	906+50.00	RT. OUTSIDE	881+50	2500.00	2500.00	9		TIE TO 2GI 602			
			884+50			18	1				
			887+50			18	1				
			890+50			38	1				
			893+50			5	1				
			896+50			39	1				
			899+50			84	1				
			902+50			32	1				
			905+00			18	1				
			926+60.00	953+00.00	RT. OUTSIDE	926+60	2640.00	2640.00	18		TIE TO 2GI 820
						929+00			18	1	
930+30						22			TIE TO 2GI-D 822		
933+00						26	1				
936+00						29	1				
938+05						89			TIE TO JB w/MH 905		
941+00						18	1				
942+55						21			TIE TO JB w/MH 915		
945+00						27	1				
948+00						20	1				
953+00						32	1				
851+15.00	854+20.00	LT. MEDIAN	851+15	305.00	305.00	N/A		TIE TO 2GI 404			
			851+70			18			TIE TO 2GI 408		
			853+00			17			TIE TO 2GI-A 407		
881+50.00	887+20.79	LT. MEDIAN	881+50	570.79	570.79	17		TIE TO 2GI 601			
			885+00			15	1				
931+66.49	943+18.69	LT. MEDIAN	931+66.49	1152.20	1152.20	17	1				
			934+20			18			TIE TO 2GI-D 901		
			938+95			26			TIE TO 2GI 904		
			942+80			31			TIE TO 2GI 914		
851+15.00	865+00.00	RT. MEDIAN	851+15	1385.00	1385.00	N/A		TIE TO 2GI 410			
			851+70			18			TIE TO 2GI 408		
			853+00			17			TIE TO 2GI-A 407		
			856+00			17			TIE TO 2GI 406		
			859+00			17			TIE TO 2GI 405		
			862+65			18			TIE TO 2GI 416		

Stantec
 Stantec Consulting Services Inc.
 801 Jones Franklin Road
 Suite 300
 Raleigh, NC 27606
 Tel. (919) 851-6866
 Fax. (919) 851-7024
 www.stantec.com
 License No. F-0672

PROJECT REFERENCE NO. <i>R-2707E</i>	SHEET NO. <i>2A-7</i>
ROADWAY DESIGN ENGINEER <i>Matthew B. Ferguson</i> 044480	PAVEMENT DESIGN ENGINEER <i>Joseph T. Holland</i> 074964
4/25/2023	4/25/2023
DOCUMENT NOT CONSIDERED FINAL UNLESS ALL SIGNATURES COMPLETED	

	PAVEMENT SCHEDULE
C4	PROP. APPROX. 3", TYPE S9.5C
D2	PROP. APPROX. 4", I19.0C
E1	PROP. APPROX. 5", TYPE B25.0C
E2	PROP. APPROX. 8", TYPE B25.0C
T	EARTH MATERIAL

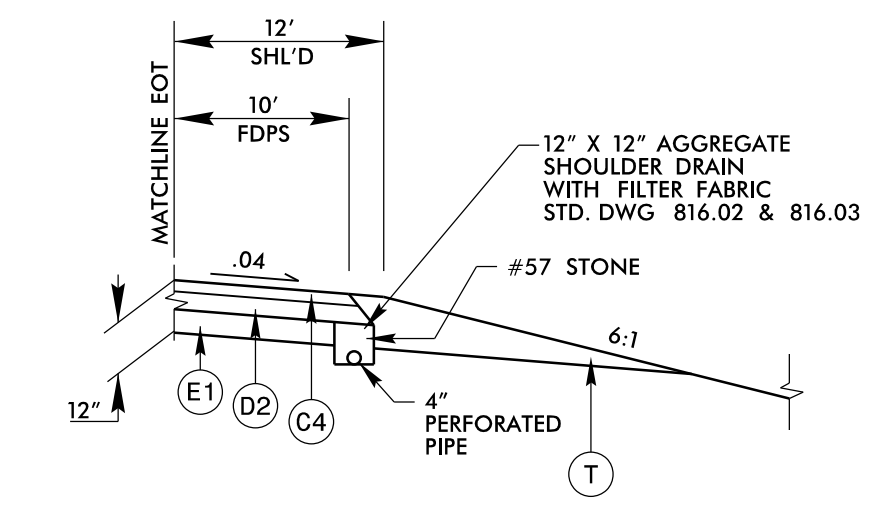

SHOULDER DRAIN DETAIL
NEW CONSTRUCTION

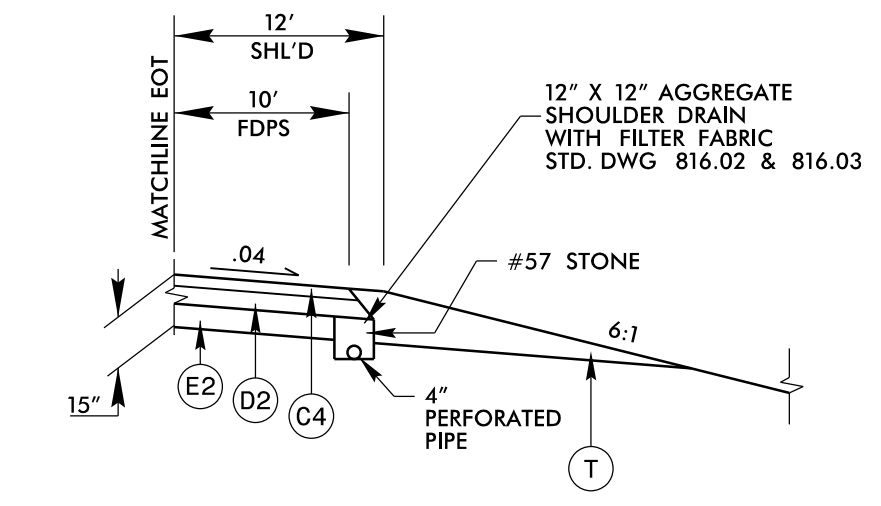

SHOULDER DRAIN DETAIL
NARROW WIDENING ALTERNATE
(NO SOIL STABILIZATION)

4/25/2023
 c:\users\mferguson\documents\paveworking\dms43124\2707E_RDY_tjup.dgn
 mferguson