

PLAN OF LEFT WING (W1)

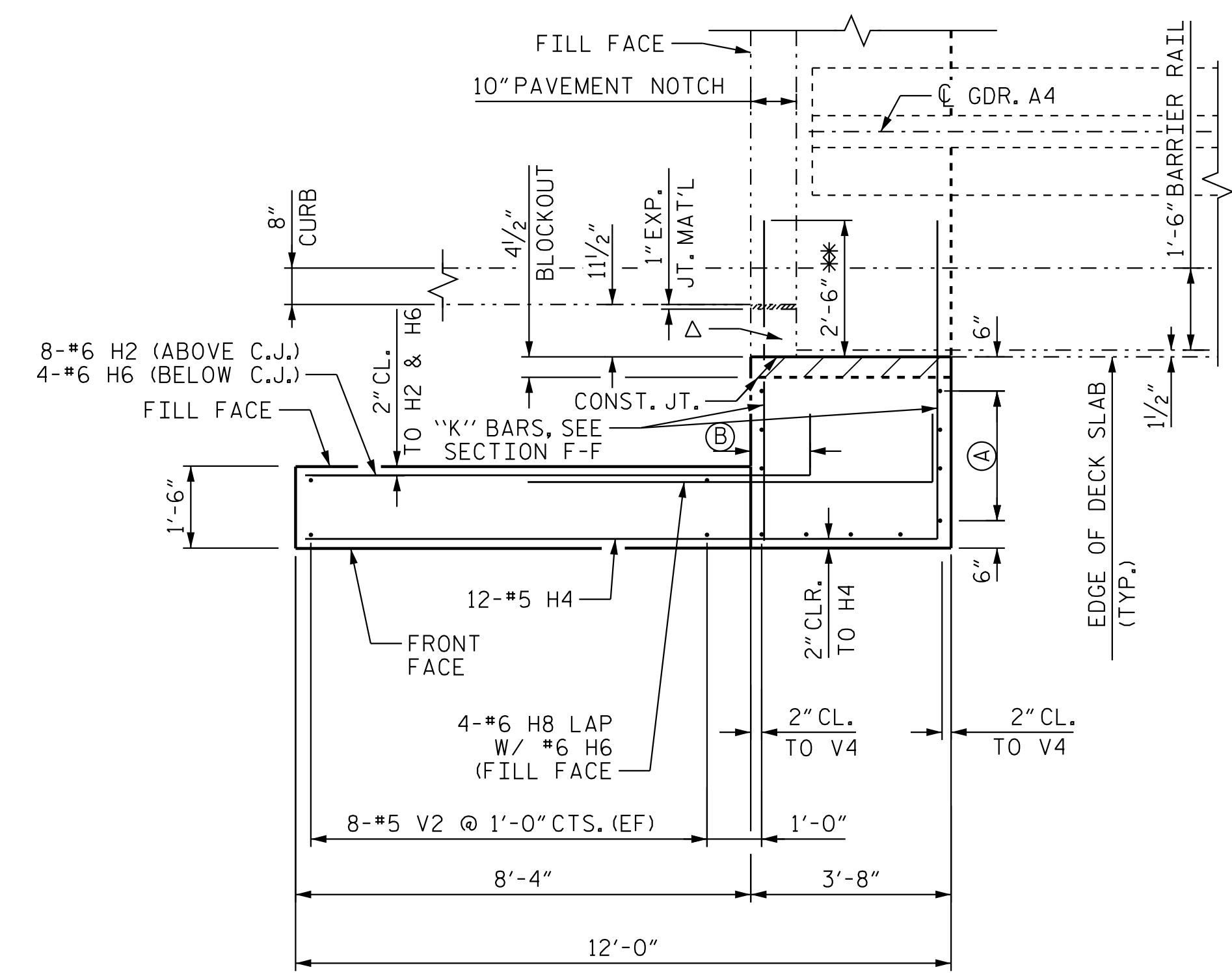

PLAN OF RIGHT WING (W2)

NOTES:
 Δ AREA BETWEEN APPROACH SLAB CURB AND BLOCKOUT SHALL MATCH THE FINISHED SURFACE OF THE BRIDGE DECK.
 CONCRETE TO BE POURED IN THE HATCHED AREA TO MATCH THE TOP OF THE CURB AND THE INTEGRAL END BENT WING ELEVATION.
 THE CONCRETE IN THE HATCHED AREA OF THE WING IS TO BE POURED AFTER THE JOINT BETWEEN THE BRIDGE DECK AND THE APPROACH SLAB HAS BEEN SAWED AND IF SLIP FORMING IS USED, THE BARRIER HAS BEEN CAST.
 #7 H7 AND #6 H8 BARS MAY BE REPOSITIONED SLIGHTLY VERTICALLY TO CLEAR CAP REINFORCEMENT AND HORIZONTALLY TO CLEAR THE PILE.
 (A) 4-#5 V4 @ EO. SPA. (FILL FACE & FRONT FACE)
 (B) 1'-1" CLEAR FROM FILL FACE TO OUTSIDE OF "H".
 (C) 4-#5 V5 @ EO. SPA. (FILL FACE & FRONT FACE).
 FOR SECTION E-E AND SECTION F-F, SEE END BENT 1 DETAILS, SHT. 3 OF 4.

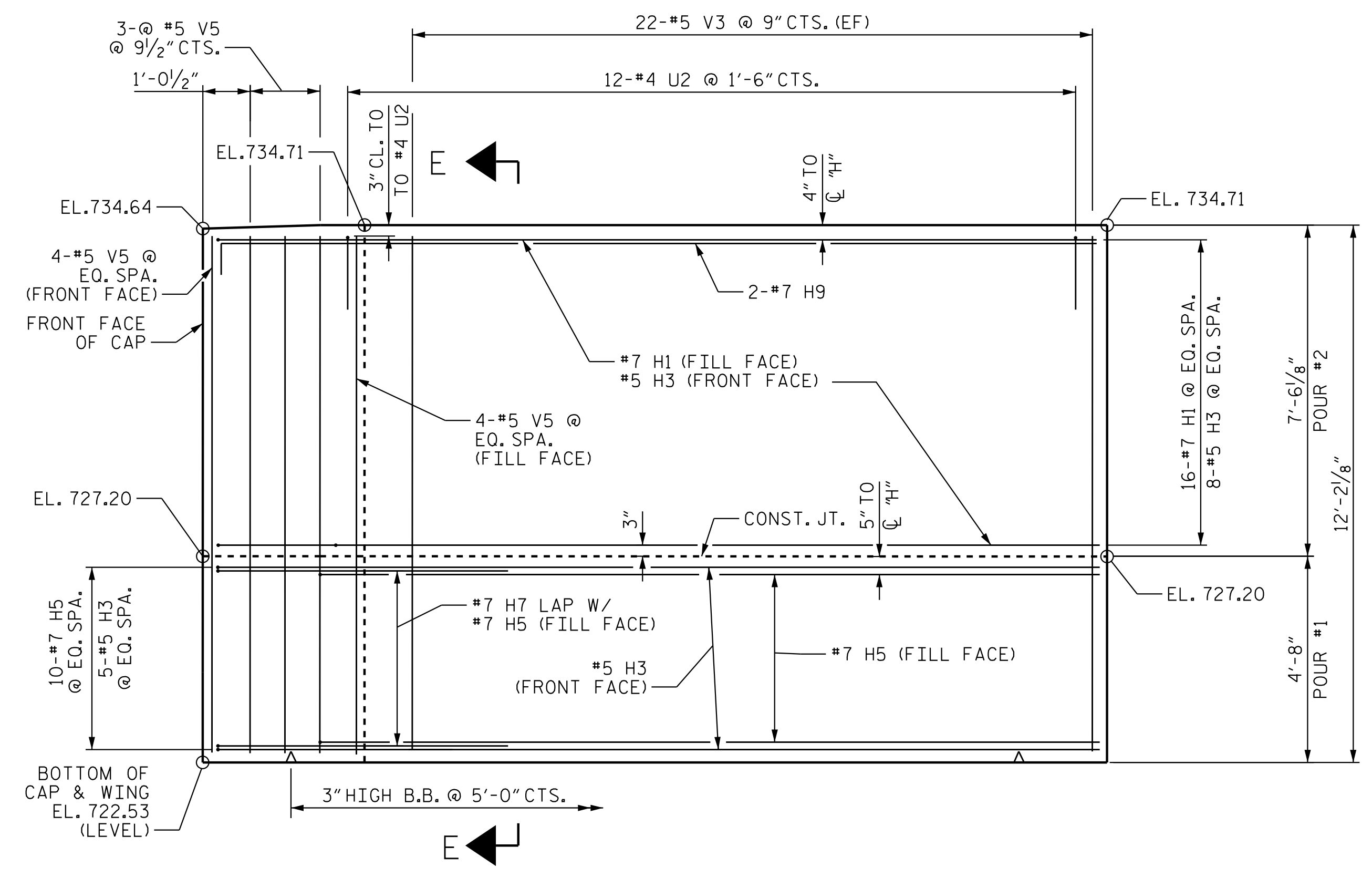

ELEVATION OF LEFT WING (W1)

NOTE: K1 & K2 BARS NOT SHOWN FOR CLARITY.

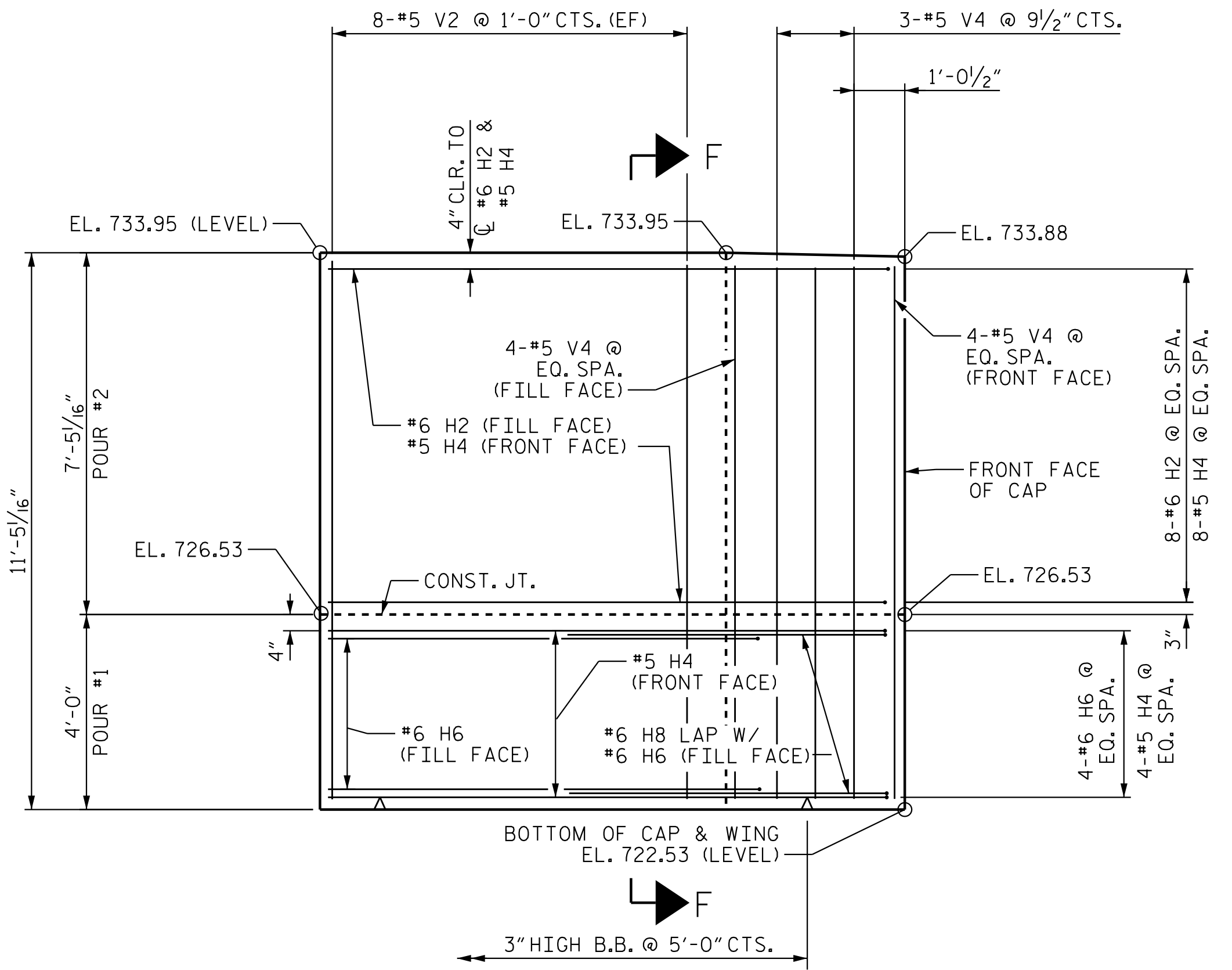

ELEVATION OF RIGHT WING (W2)

NOTE: K1 & K2 BARS NOT SHOWN FOR CLARITY.

PROJECT NO. R-2707D
 CLEVELAND COUNTY
 STATION: 810+00.00 -L-

SHEET 2 OF 4
 DEPARTMENT OF TRANSPORTATION
 RALEIGH
 SUBSTRUCTURE
 END BENT 1 - WING WALLS
 (RL)

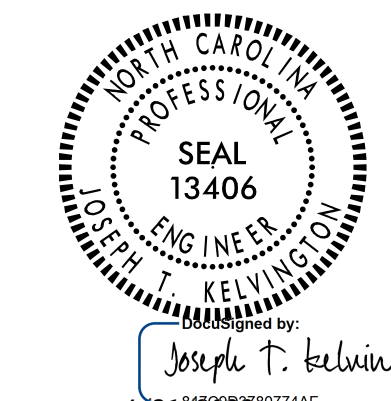

REVISIONS						SHEET NO. S9-21
NO.	BY:	DATE:	NO.	BY:	DATE:	
1			3			TOTAL SHEETS 30
2			4			

DOCUMENT NOT CONSIDERED FINAL UNLESS ALL SIGNATURES COMPLETED

Stantec
 Stantec Consulting Services Inc.
 801 Jones Franklin Road
 Suite 300
 Raleigh, NC 27606
 Tel. (919) 851-6866
 Fax. (919) 851-7024
 www.stantec.com
 License No. F-0672

NOTE: TOP SURFACE OF END BENT WING CAST ON TOP OF THE END BENT CAP SHALL BE SLOPED TRANSVERSELY FROM FILL FACE OF THE CAP TO FRONT FACE AT A RATE OF 1/4" / FT.

(EF) DENOTES EACH FACE.

* #4 K2 2'-6" PROJECTION BEYOND CONST. JOINT.

DRAWN BY: J.E. HAGENBUSH DATE: 12/09/22
 CHECKED BY: J.T. KELVINGTON DATE: 12/12/22
 DESIGN ENGINEER OF RECORD: J.T. KELVINGTON DATE: 04/21/23