

NOTES

STIRRUPS IN CAP MAY BE SHIFTED AS NECESSARY TO CLEAR ANCHOR BOLTS.
 HOOKS ON "V" BARS MAY BE TURNED AS NECESSARY FOR PLACING REINFORCING STEEL.
 FOR VIEW A-A, SEE "BENT 1 DETAILS", SHEET 2 OF 2.
 FOR PILE SPLICE DETAILS, SEE "END BENT 1 DETAILS", SHEET 3 OF 3.
 FOR SECTION B-B, SEE "BENT 1 DETAILS", SHEET 2 OF 2.

* INVERT ALTERNATE STIRRUPS

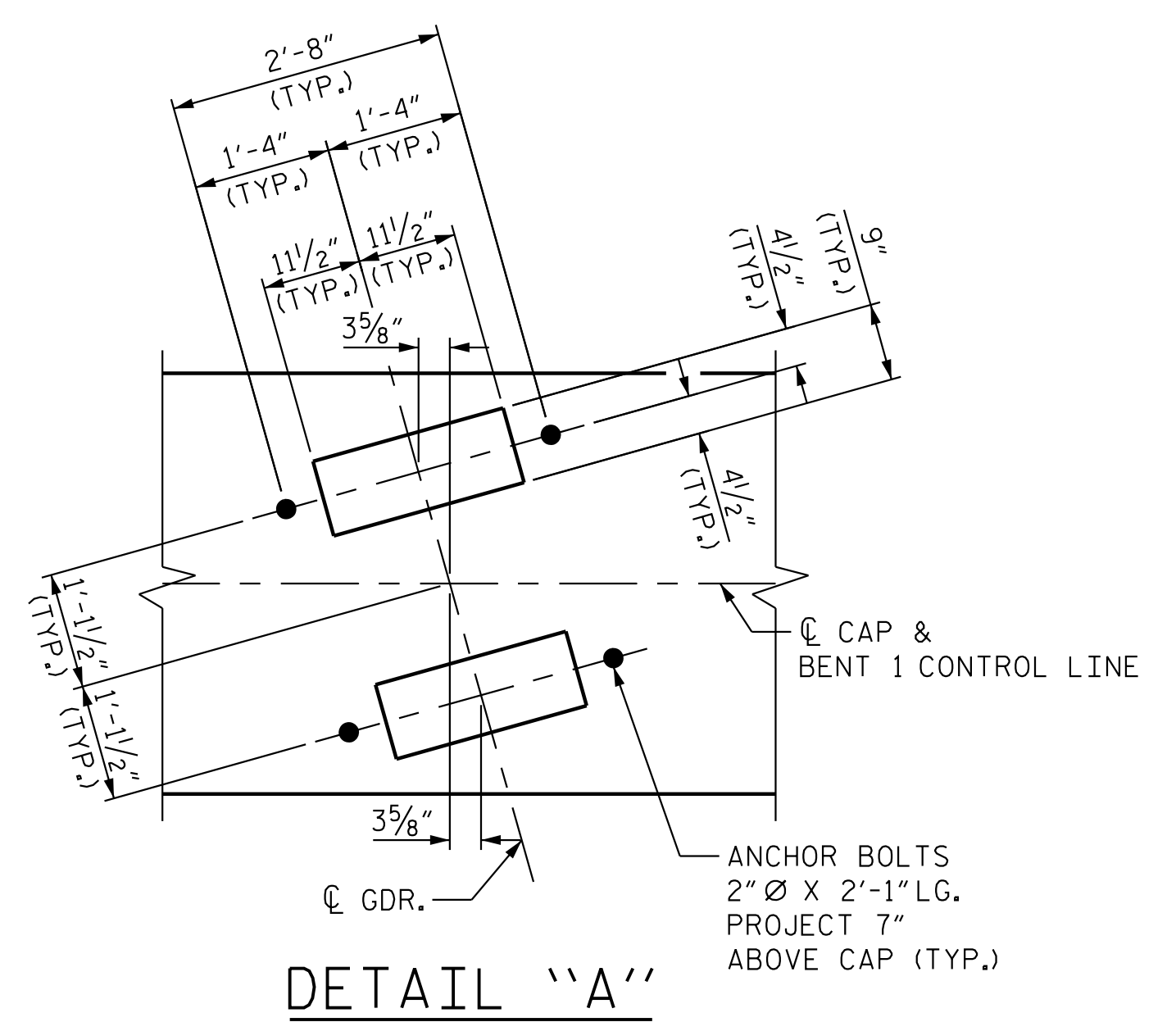
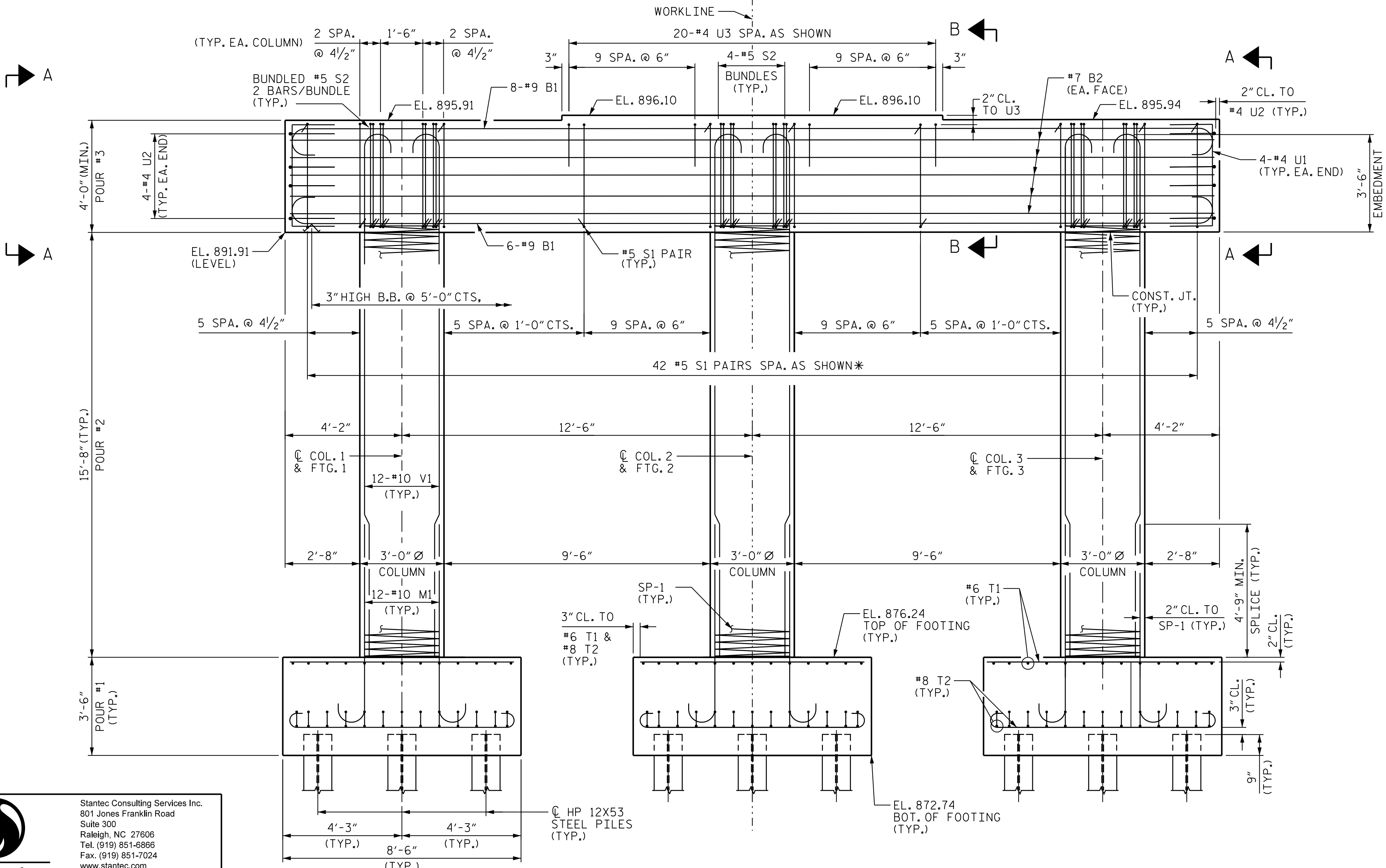

ELEVATION

PROJECT NO. R-2707D
CLEVELAND COUNTY
 STATION: 19+82.46 -Y1-

SHEET 1 OF 2

STATE OF NORTH CAROLINA
 DEPARTMENT OF TRANSPORTATION
 RALEIGH
 SUBSTRUCTURE
 BENT 1



REVISIONS						SHEET NO. S1-25
NO.	BY:	DATE:	NO.	BY:	DATE:	
1			3			TOTAL SHEETS 32
2			4			

DOCUMENT NOT CONSIDERED FINAL UNLESS ALL SIGNATURES COMPLETED

Stantec Consulting Services Inc.
 801 Jones Franklin Road
 Suite 300
 Raleigh, NC 27606
 Tel. (919) 851-6866
 Fax. (919) 851-7024
 www.stantec.com
 License No. F-0672

DRAWN BY: J. B. GEILE DATE: 02/06/18
 CHECKED BY: N. D'AIUTO DATE: 02/13/18
 DESIGN ENGINEER OF RECORD: J. KELVINGTON DATE: 04/27/23

4/27/2023 10:25:44 AM j_hagenbush 4/27/2023 10:25:44 AM j_hagenbush 4/27/2023 10:25:44 AM j_hagenbush