

PROJECT REFERENCE NO. R-2707D	SHEET NO. 2G-2
GEOTECHNICAL ENGINEER  DocuSigned by: Jeremy Hamm 462202348BC46A SIGNATURE	ENGINEER DATE: 3/6/2023 SIGNATURE: _____ DATE: _____
DOCUMENT NOT CONSIDERED FINAL UNLESS ALL SIGNATURES COMPLETED	

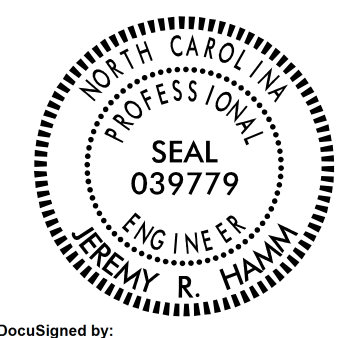
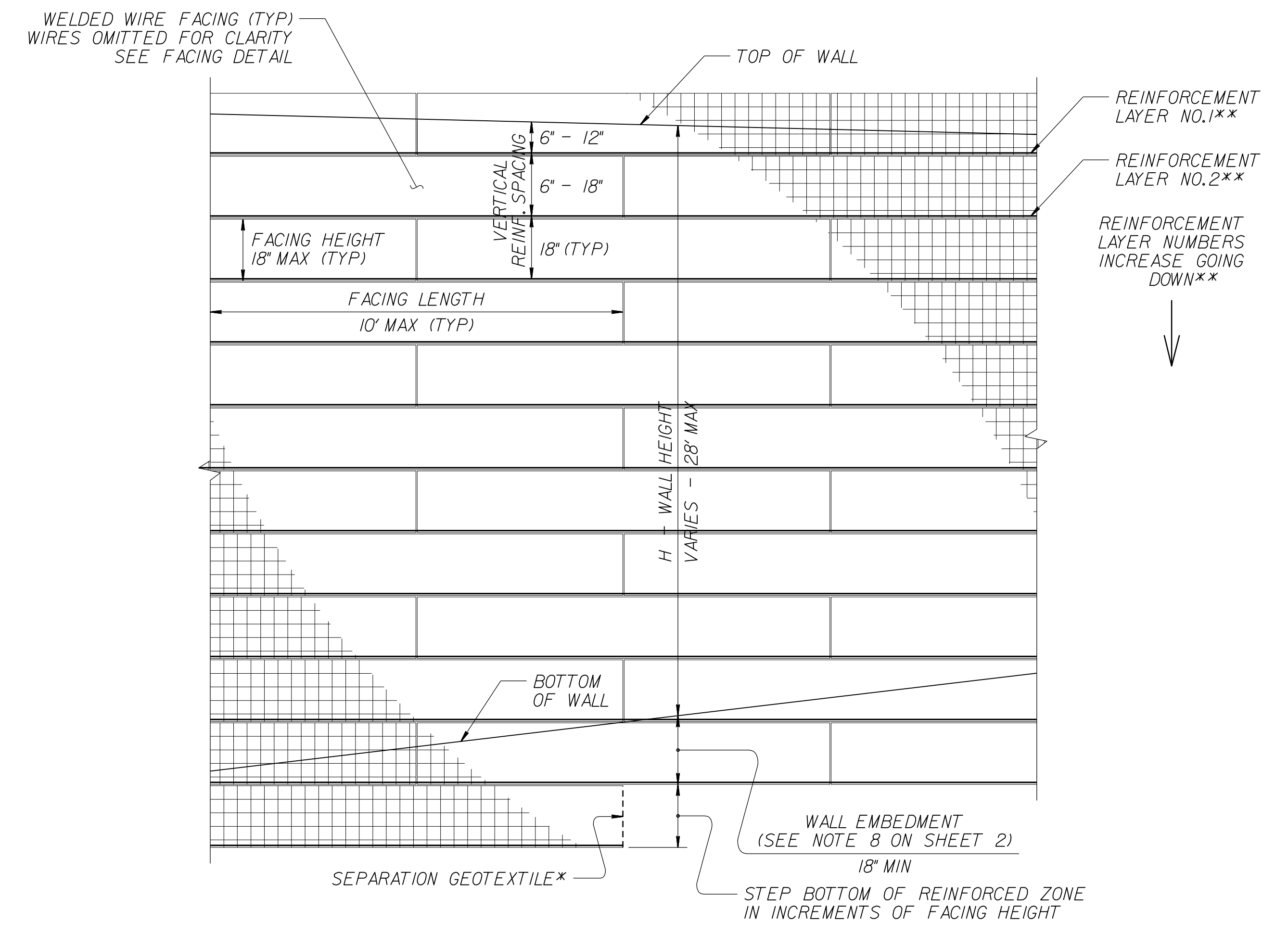
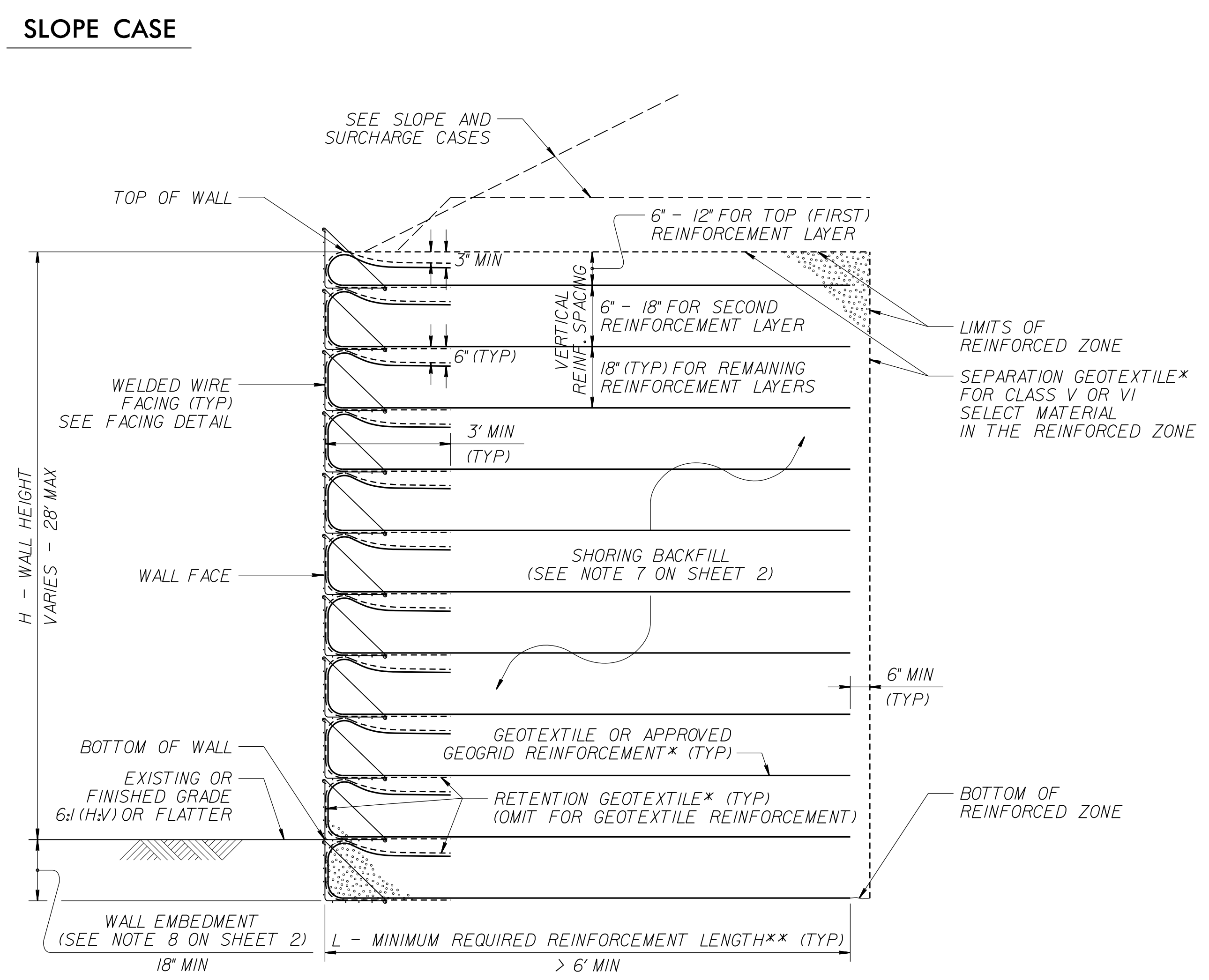
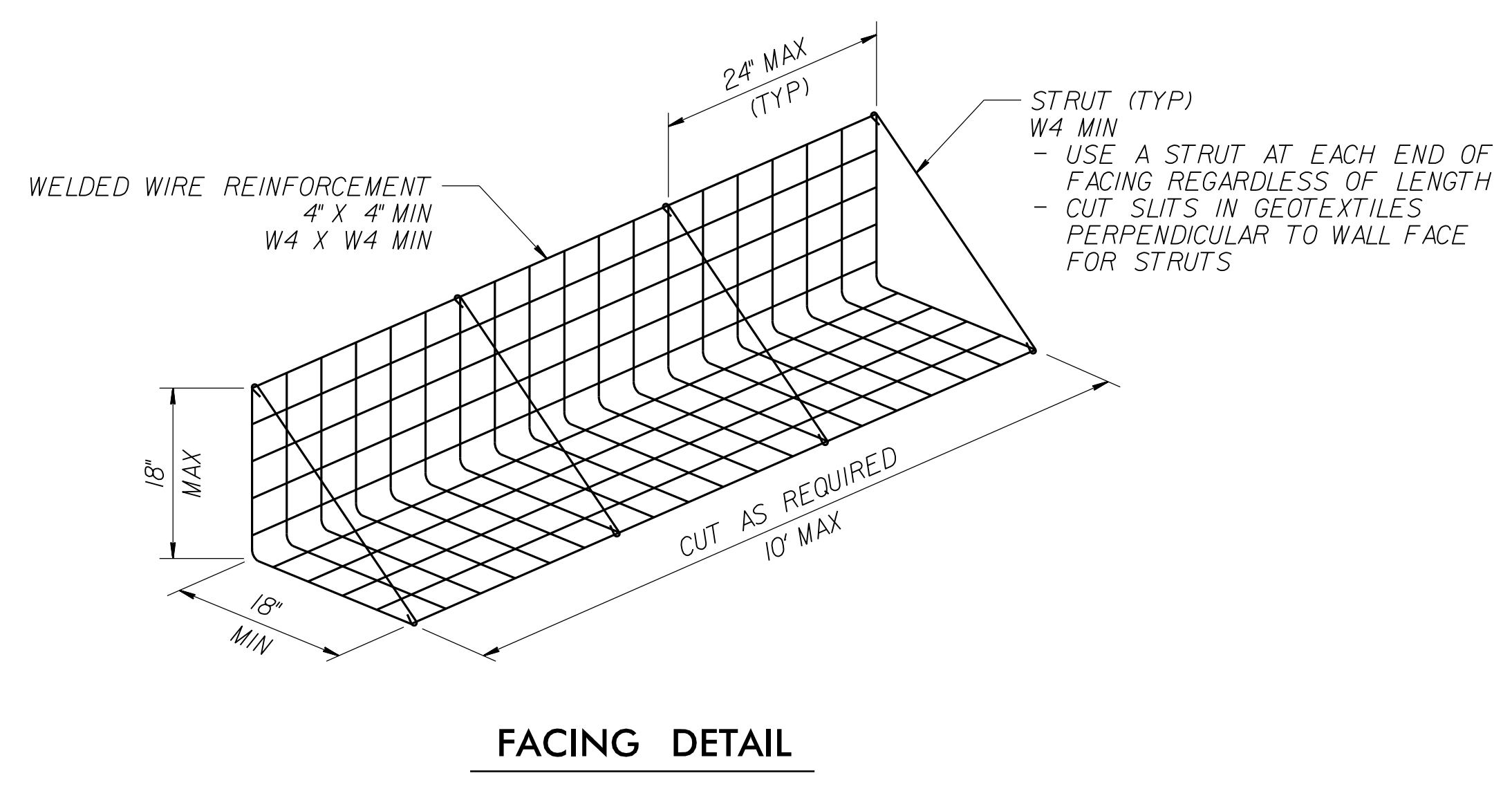
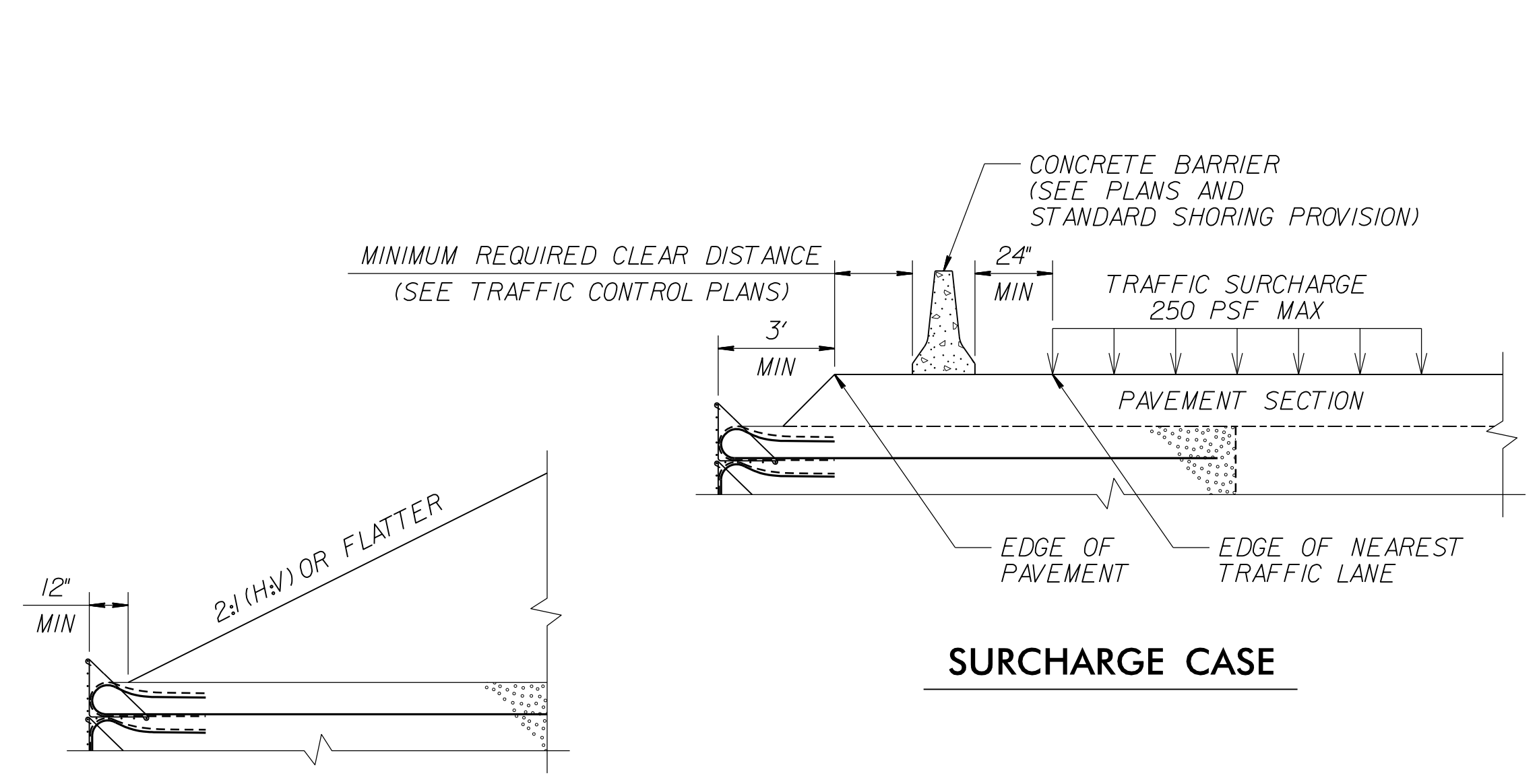
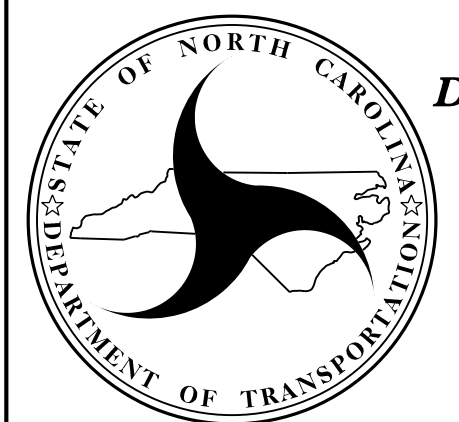

 NORTH CAROLINA DEPARTMENT OF TRANSPORTATION DIVISION OF HIGHWAYS GEOTECHNICAL ENGINEERING UNIT	STANDARD DETAIL NO. 1801.02
	STANDARD TEMPORARY WALL SHEET 1 OF 3 DATE: 11-19-13