

T.I.P.: U-2729

**STATE OF NORTH CAROLINA
DEPARTMENT OF TRANSPORTATION**

**PAVEMENT MARKING PLAN
FORSYTH COUNTY**

TIP NO. U-2729	SHEET NO. PMP - 1
APPROVED: _____	
DATE: _____	
SEAL	
	
DOCUMENT NOT CONSIDERED FINAL UNLESS ALL SIGNATURES COMPLETED	

INDEX

SHEET NO.	DESCRIPTION
PMP - 1	PAVEMENT MARKING PLAN TITLE SHEET
PMP - 2	PAVEMENT MARKING SCHEDULE SHEET
PMP - 3	REVISED PAVEMENT MARKING ROADWAY STANDARD DRAWING
PMP - 4 - 6A	PAVEMENT MARKING DETAIL SHEETS

ROADWAY STANDARD DRAWING

THE FOLLOWING ROADWAY STANDARDS AS APPEAR IN "ROADWAY STANDARD DRAWINGS" - PROJECT SERVICES UNIT - N.C. DEPARTMENT OF TRANSPORTATION - RALEIGH, N.C., DATED JANUARY 2018 ARE APPLICABLE TO THIS PROJECT AND BY REFERENCE HEREBY ARE CONSIDERED A PART OF THESE PLANS:

STD. NO.	TITLE
1205.01	PAVEMENT MARKINGS - LINE TYPES AND OFFSETS
1205.02	PAVEMENT MARKINGS - TWO-LANE AND MULTILANE ROADWAYS
1205.03	PAVEMENT MARKINGS - EXIT AND ENTRANCE RAMP
1205.04	PAVEMENT MARKINGS - INTERSECTIONS
1205.05	PAVEMENT MARKINGS - TURN LANES
1205.06	PAVEMENT MARKINGS - LANE DROPS
1205.07	PAVEMENT MARKINGS - PEDESTRIAN CROSSWALKS
1205.08	PAVEMENT MARKINGS - SYMBOLS AND WORD MESSAGES
1205.09	PAVEMENT MARKINGS - PAINTED ISLANDS
1205.12	PAVEMENT MARKINGS - BRIDGES
1205.14	PAVEMENT MARKINGS - ROUNDABOUTS
1250.01	RAISED PAVEMENT MARKERS - INSTALLATION SPACING
1251.01	RAISED PAVEMENT MARKERS - PERMANENT AND TEMPORARY
1253.01	RAISED PAVEMENT MARKERS - SNOWPLOWABLE
1261.01	GUARDRAIL AND BARRIER DELINEATORS - INSTALLATION SPACING
1261.02	GUARDRAIL AND BARRIER DELINEATORS - TYPES AND MOUNTING
1262.01	GUARDRAIL END DELINEATION

GENERAL NOTES

THE FOLLOWING GENERAL NOTES APPLY AT ALL TIMES FOR THE DURATION OF THE CONSTRUCTION PROJECT, EXCEPT WHEN OTHERWISE NOTED IN THE PLAN, OR DIRECTED BY THE ENGINEER.

- A) INSTALL PAVEMENT MARKINGS AND PAVEMENT MARKERS ON THE FINAL SURFACE AS FOLLOWS:

ROAD NAME	MARKING	MARKER
ALL ROADS	THERMOPLASTIC WITH STANDARD BEADS	NON-CAST IRON SNOWPLOWABLE
BRIDGE DECK	COLD APPLIED PLASTIC II OR III	RAISED
US 52	THERMOPLASTIC WITH STANDARD BEADS	NON-CAST IRON SNOWPLOWABLE

- C) PLACE TWO APPLICATIONS OF PAINT PAVEMENT MARKINGS ON THE FINAL WEARING SURFACE. PLACE THE SECOND APPLICATION OF PAINT UPON SUFFICIENT DRYING TIME OF THE FIRST.
- D) TIE PROPOSED PAVEMENT MARKING LINES TO EXISTING PAVEMENT MARKING LINES.
- E) REMOVE/REPLACE ANY CONFLICTING/DAMAGED PAVEMENT MARKINGS AND MARKERS.
- F) PASSING ZONES WILL BE DETERMINED IN THE FIELD AND MUST BE APPROVED BY THE ENGINEER.
- G) STOP BAR LOCATION AT NON-SIGNALIZED INTERSECTIONS MAY BE ADJUSTED AS DIRECTED BY THE ENGINEER.
- H) REMOVE ALL RESIDUE AND SURFACE LAITANCE BY ACCEPTABLE METHODS ON CONCRETE BRIDGE DECKS PRIOR TO PLACING (insert marking material) PAVEMENT MARKING MATERIAL.
- I) UNLESS OTHERWISE SPECIFIED, HEATED-IN-PLACE THERMOPLASTIC MAY BE USED IN LIEU OF EXTRUDED THERMOPLASTIC FOR STOP BARS, SYMBOLS, CHARACTERS AND DIAGONALS. IF HEATED-IN-PLACE IS USED, IT SHALL BE PAID FOR USING THE EXTRUDED THERMOPLASTIC PAY ITEM.
- J) UNLESS OTHERWISE SPECIFIED, HEATED-IN-PLACE THERMOPLASTIC MAY BE USED IN LIEU OF COLD APPLIED PLASTIC FOR STOP BARS, SYMBOLS, CHARACTERS AND DIAGONALS ON ASPHALT OR CONCRETE ROADWAYS. IF HEATED-IN-PLACE IS USED, IT SHALL BE PAID FOR USING THE COLD APPLIED PAY ITEM.
- K) TYPE III COLD APPLIED PLASTIC MAY BE USED IN LIEU OF TYPE II COLD APPLIED PLASTIC. IF TYPE III COLD APPLIED PLASTIC IS USED, IT SHALL BE PAID FOR USING THE TYPE II COLD APPLIED PLASTIC PAY ITEM.
- L) ALL BICYCLE LANE SYMBOLS SHALL BE HEATED-IN-PLACE THERMOPLASTIC. SYMBOLS SHALL BE PAID FOR USING THE HEATED-IN-PLACE PAY ITEM.
- M) SEE ROADWAY PLANS FOR ALTERNATE CURB RAMP DESIGNS WHEN INDICATED ON PAVEMENT MARKING DETAIL SHEETS.

PLAN SUBMITTED TO:

CONNIE JAMES, PE - DIVISION PROJECT ENGINEER

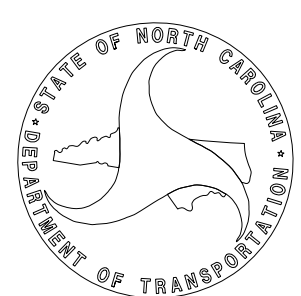

PLAN PREPARED BY: MOTT MACDONALD

DAVID W BISSETTE, PE PRINCIPAL PROJECT MANAGER
SAM COLEMAN, PE PROJECT ENGINEER

M MOTT MACDONALD 1 & E, LLC
1101 HAYNES STREET, SUITE 101
RALEIGH, NC 27604
M MOTT MACDONALD NC LICENSE NO. F-0669

APPROVED: _____

DATE: _____

SEAL



DOCUMENT NOT CONSIDERED FINAL
UNLESS ALL SIGNATURES COMPLETED

**PAVEMENT
MARKING SCHEDULE**

SYMBOL DESCRIPTION

THERMOPLASTIC (4", 90 MILS)

- T11 YELLOW SINGLE CENTER
- T12 10 FT. YELLOW SKIP
- T13 YELLOW DOUBLE CENTER
- T14 2FT.-6FT./SP YELLOW MINISKIP
- T1 WHITE EDGELINE
- T2 WHITE SOLID LANE LINE
- T3 10 FT. WHITE SKIP
- T4 3FT. - 9FT./SP WHITE MINISKIP
- T5 2FT. - 6FT./SP WHITE MINISKIP

THERMOPLASTIC (6", 90 MILS)

- T20 WHITE EDGELINE
- T21 WHITE SOLID LANE LINE
- T22 10FT. WHITE SKIP
- T23 3FT. - 9FT./SK WHITE MINISKIP
- T30 YELLOW EDGELINE
- T31 YELLOW SINGLE CENTER

THERMOPLASTIC (8", 90 MILS)

- T40 WHITE GORELINE
- T41 WHITE DIAGONAL
- T42 YELLOW DIAGONAL
- T43 WHITE SOLID LANE LINE
- T44 3FT. - 9FT./SP WHITE MINISKIP
- T45 3FT. - 3FT./SP WHITE MINISKIP
- T46 WHITE CROSSWALK LINE

THERMOPLASTIC (12", 90 MILS)

- T50 WHITE GORELINE
- T51 WHITE DIAGONAL
- T53 WHITE SOLID LANE LINE

THERMOPLASTIC GENERIC PAVEMENT MARKING ITEM

- T61 WHITE STOPBAR (24", 90 MIL)
- T62 WHITE CROSSWALK LINE (24", 90 MIL)

THERMOPLASTIC PAVEMENT MARKING SYMBOLS (90 MILS)

- T70 ↶ LEFT TURN ARROW
- T71 ↷ RIGHT TURN ARROW
- T72 ↑ STRAIGHT ARROW
- T73 ↵ COMBO STRAIGHT/LEFT
- T79 ➔ MERGE ARROW
- T80 ↑ WRONG-WAY RAMP ARROW
- T100 ALPHANUMERIC CHARACTER
- T103 24" YIELD LINE TRIANGLE
- T112 ↷ FISH-HOOK RIGHT/STRAIGHT ARROW
- T116 ↶ FISH-HOOK W/CIRCLE LEFT ARROW
- T117 ↵ FISH-HOOK W/CIRCLE LEFT/STRAIGHT ARROW

COLD APPLIED PLASTIC (4")

- C11 YELLOW SINGLE CENTER
- C1 WHITE EDGELINE
- C2 WHITE SOLID LANE LINE
- C3 10 FT. WHITE SKIP
- C4 3FT. - 9FT./SP WHITE MINISKIP

COLD APPLIED PLASTIC PAVEMENT MARKING SYMBOLS

- C70 ↶ LEFT TURN ARROW
- C72 ↑ STRAIGHT ARROW

PAVEMENT MARKERS

- MA YELLOW & YELLOW RAISED
- MB CRYSTAL & RED RAISED
- ME YELLOW & YELLOW NON-CAST IRON SNOWPLOWABLE
- MF CRYSTAL & RED NON-CAST IRON SNOWPLOWABLE

3/23/2023 10:30:50 AM C:\Users\jld\OneDrive\Documents\TrafficControl\Signing\Pavement Marking\U-2729_Sgn_PMP_2.dgn User: jld

PLANS PREPARED FOR THE NCDOT BY:

M MOTT MACDONALD I & E, LLC
1101 HAYNES STREET, SUITE 101
RALEIGH, NC 27604
M MOTT MACDONALD NC LICENSE NO. F-0669

PAVEMENT MARKING SCHEDULE



DOCUMENT NOT CONSIDERED FINAL UNLESS ALL SIGNATURES COMPLETED

TIP NO. SHEET NO.

DocuSigned by: *Matthew V. Springer*

APPROVED: *Matthew V. Springer*

DATE: 8/13/2019

SEAL

STATE OF NORTH CAROLINA
DEPT. OF TRANSPORTATION
DIVISION OF HIGHWAYS
RALEIGH, N.C.

ENGLISH DETAIL DRAWING FOR
PAVEMENT MARKINGS
INTERSECTIONS

SHEET 2 OF 2
1205D04

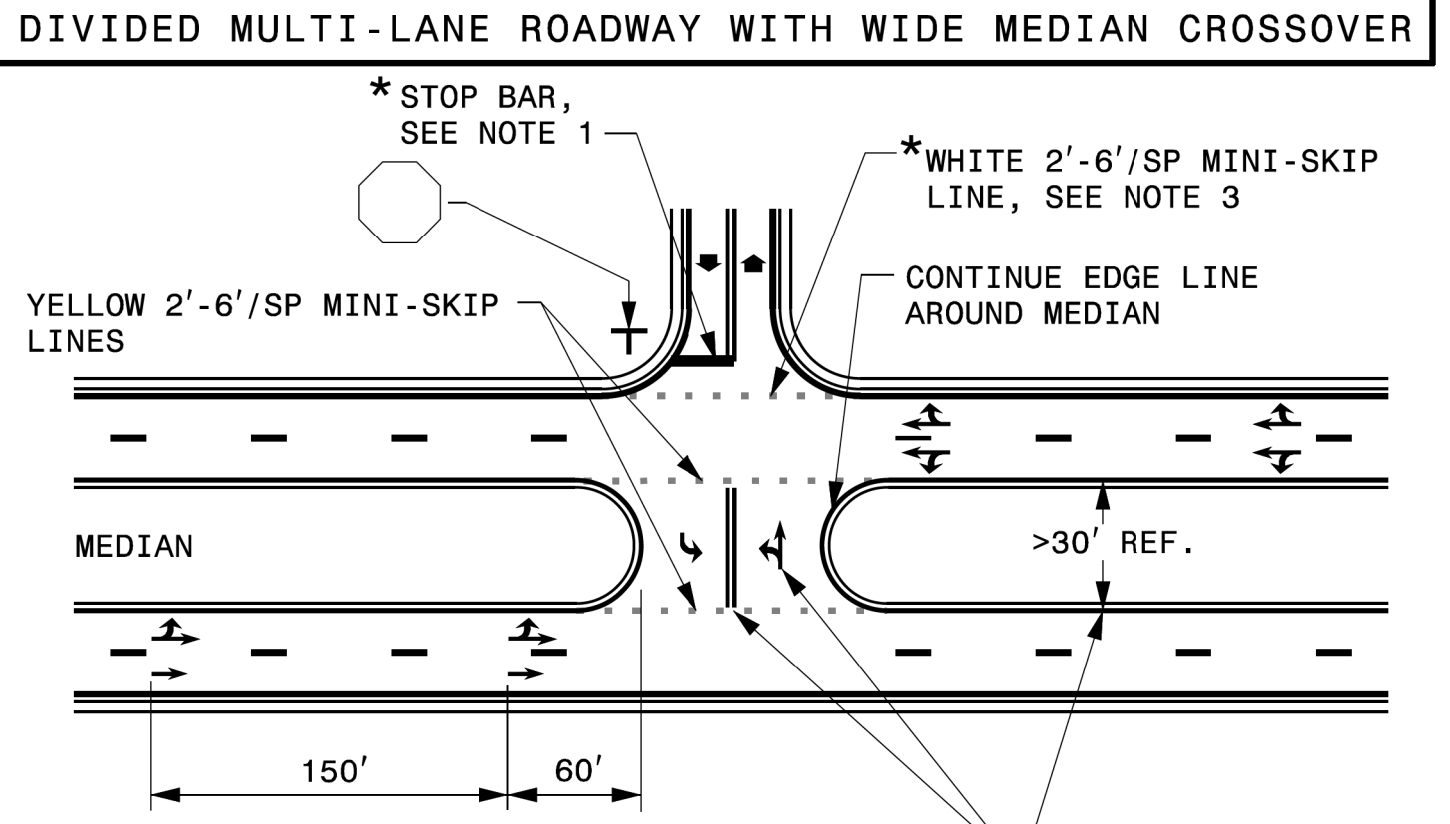
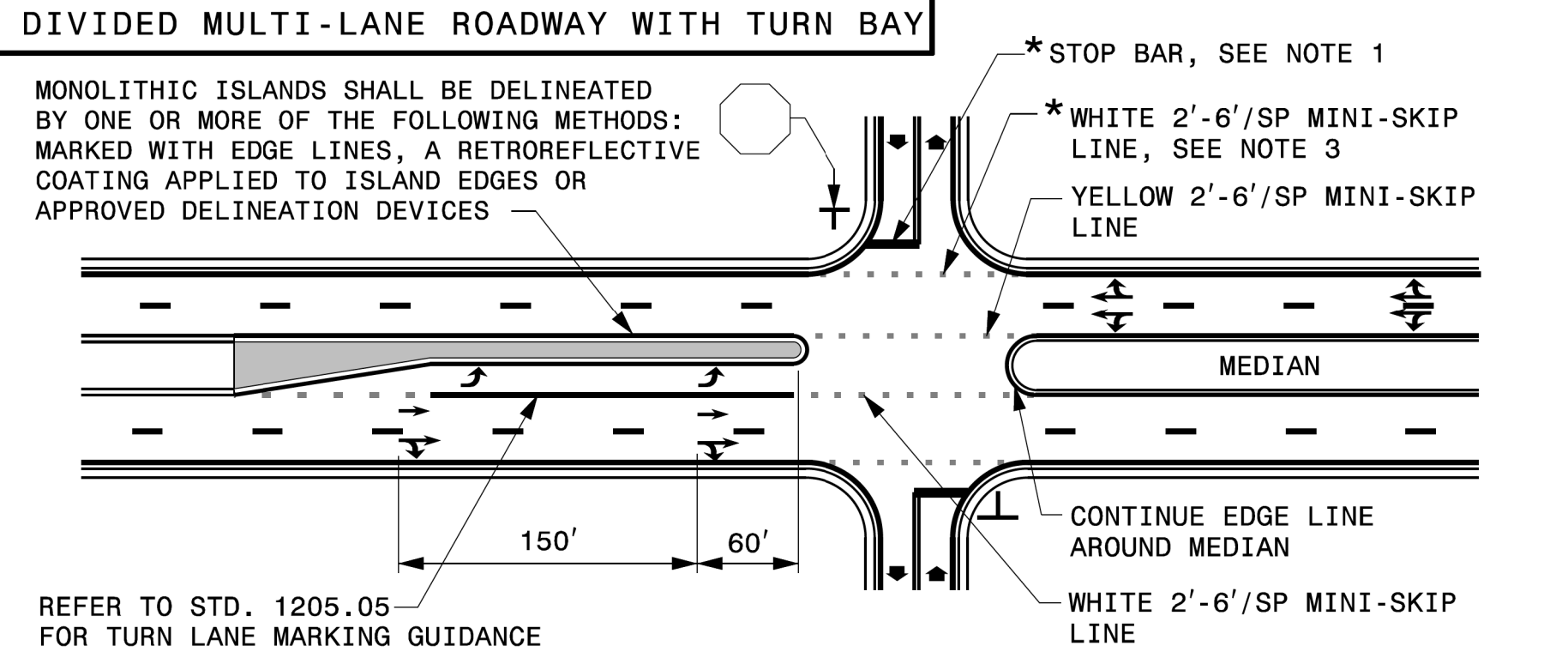
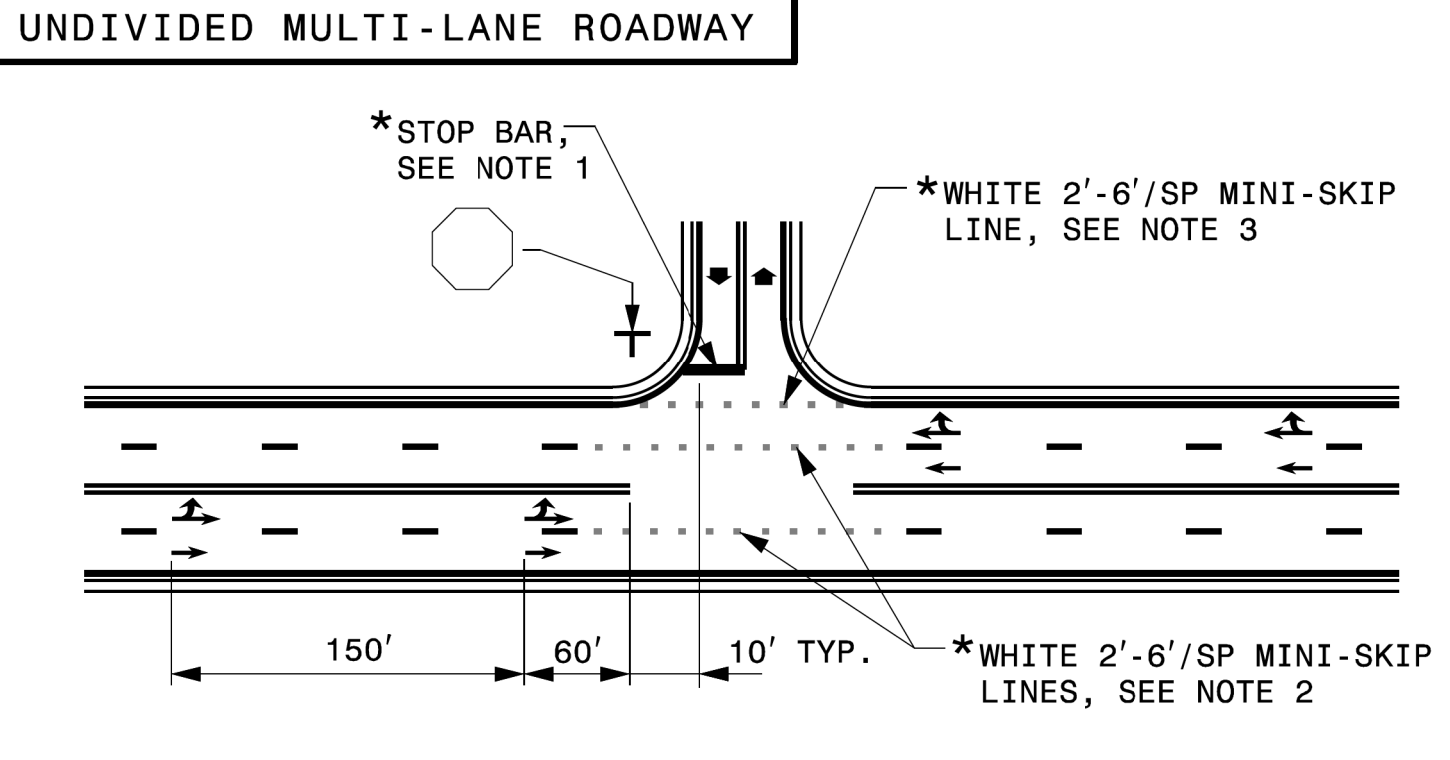
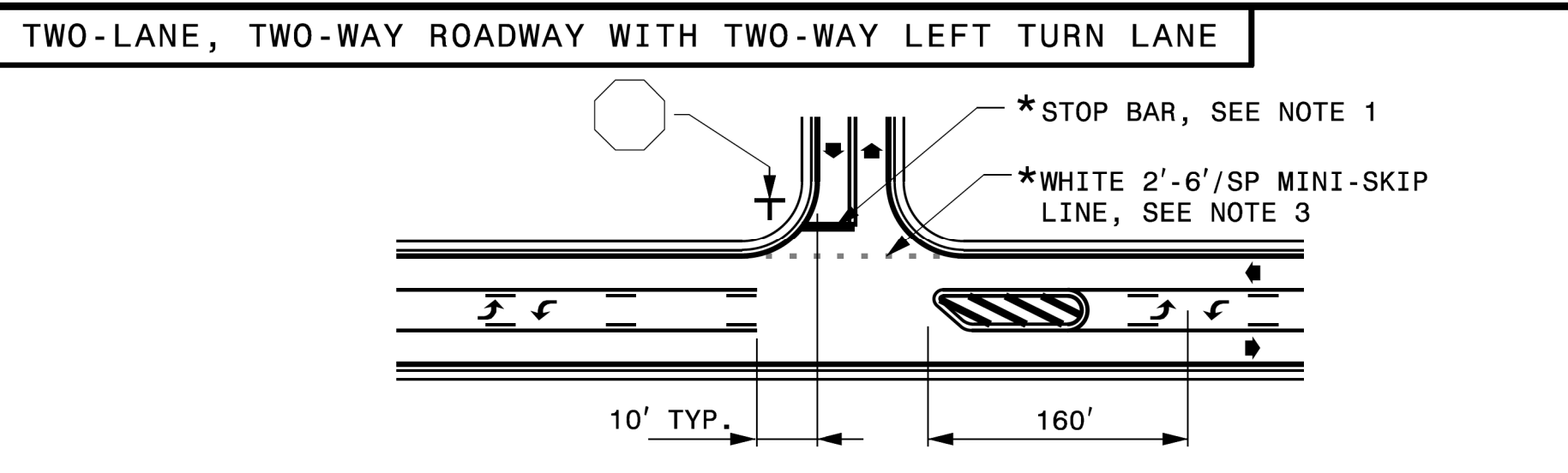
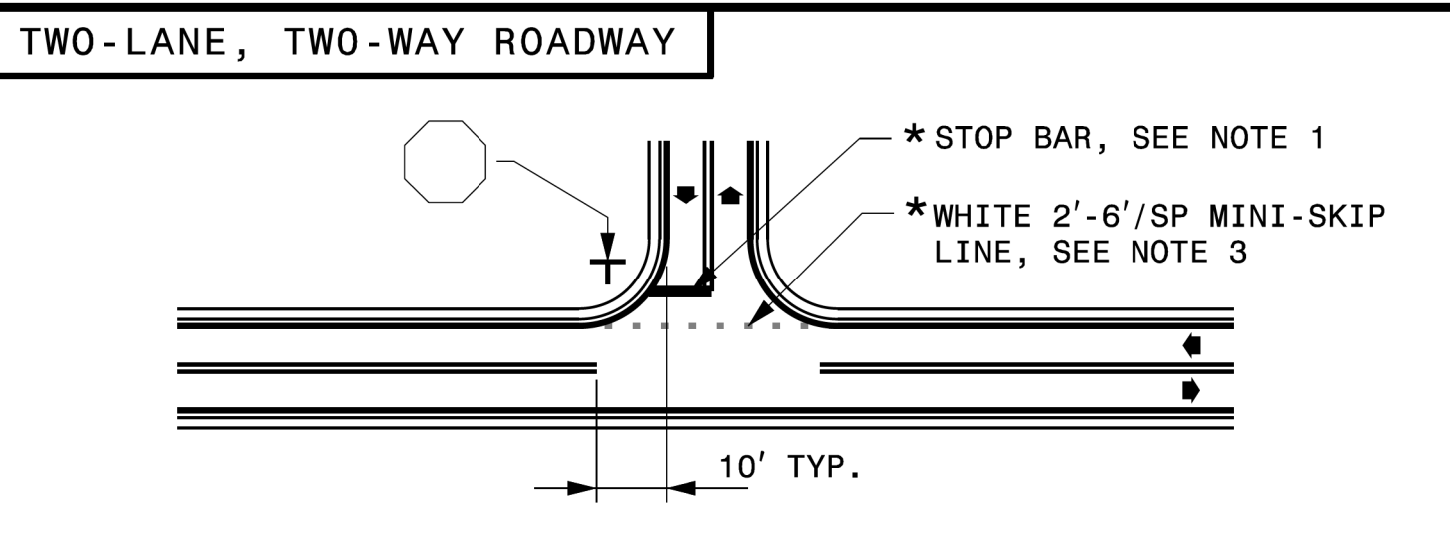

- GENERAL NOTES:
- 1- PLACEMENT OF STOP BARS AT NON-SIGNALIZED INTERSECTIONS IS OPTIONAL AND USED WHERE IT IS IMPORTANT TO INDICATE THE POINT WHICH VEHICLES ARE REQUIRED TO STOP. PLACE STOP BARS NO LESS THAN 4 FEET AND NO MORE THAN 30 FEET FROM THE NEAREST EDGE OF THE INTERSECTING ROADWAY. USE 10 FEET AS THE TYPICAL SETBACK DISTANCE OR AS DIRECTED BY THE ENGINEER.
 - 2- MINI-SKIP LANE LINE EXTENSIONS SHOULD BE USED AT INTERSECTIONS THAT HAVE REDUCED VISIBILITY CONDITIONS SUCH AS OFFSET, SKEWED, OR CURVED ROADWAYS.
 - 3- MINI-SKIP EDGE LINE EXTENSIONS MAY BE PLACED THROUGH INTERSECTIONS AND MAJOR DRIVEWAYS.
 - 4- REFER TO ROADWAY STANDARD DRAWINGS 1205.01, 1205.02, 1205.05, 1205.08 AND 1205.09 FOR ADDITIONAL PAVEMENT MARKING GUIDANCE.

LEGEND

STOP SIGN	STATIONARY SIGN
DIRECTION OF TRAFFIC FLOW	PAVEMENT MARKING SYMBOLS
* OPTIONAL	

USE DOUBLE YELLOW CENTER LINE AND ARROW SYMBOLS IN MEDIAN CROSSOVER WHEN WIDTH OF MEDIAN EXCEEDS 30 FT, OTHERWISE THEY ARE NOT REQUIRED.

STATE OF NORTH CAROLINA
DEPT. OF TRANSPORTATION
DIVISION OF HIGHWAYS
RALEIGH, N.C.

ENGLISH DETAIL DRAWING FOR
PAVEMENT MARKINGS
INTERSECTIONS

SHEET 2 OF 2
1205D04

REVISED PAVEMENT MARKING ROADWAY STANDARD DRAWING

REVISED PAVEMENT MARKING ROADWAY STANDARD DRAWING

3/23/2023
G:\303350_DD\2\RC-U-2729-TrafficControl\Signing\Pavement Marking\U-2729-Sgn-PMP-3.dgn
User:10185144

PLANS PREPARED FOR THE NCDOT BY:
M MOTT MACDONALD I & E, LLC
1101 HAYNES STREET, SUITE 101
RALEIGH, NC 27604
M MOTT MACDONALD
NC LICENSE NO. F-0669

UR\13\19\Standards\Standards and Drawings\Drawings\2018 Standard Dwg\Division 12 Final\2050402_08-13-19.dgn
User:dstokes

APPROVED: _____

DATE: _____

SEAL



**DOCUMENT NOT CONSIDERED FINAL
UNLESS ALL SIGNATURES COMPLETED**

THERMOPLASTIC PAVEMENT MARKING SYMBOLS

- T70 ↤ LEFT TURN ARROW
- T71 ↪ RIGHT TURN ARROW
- T72 ↑ STRAIGHT ARROW
- T73 ↤↪ COMBO STRAIGHT/LEFT
- T79 ↗ MERGE ARROW
- T100 ALPHANUMERIC CHARACTER
- T103 24" YIELD LINE TRIANGLE
- T112 ↤ FISH-HOOK RIGHT/STRAIGHT ARROW
- T116 ↤ FISH-HOOK W/CIRCLE LEFT ARROW
- T117 ↤ FISH-HOOK W/CIRCLE LEFT/STRAIGHT ARROW

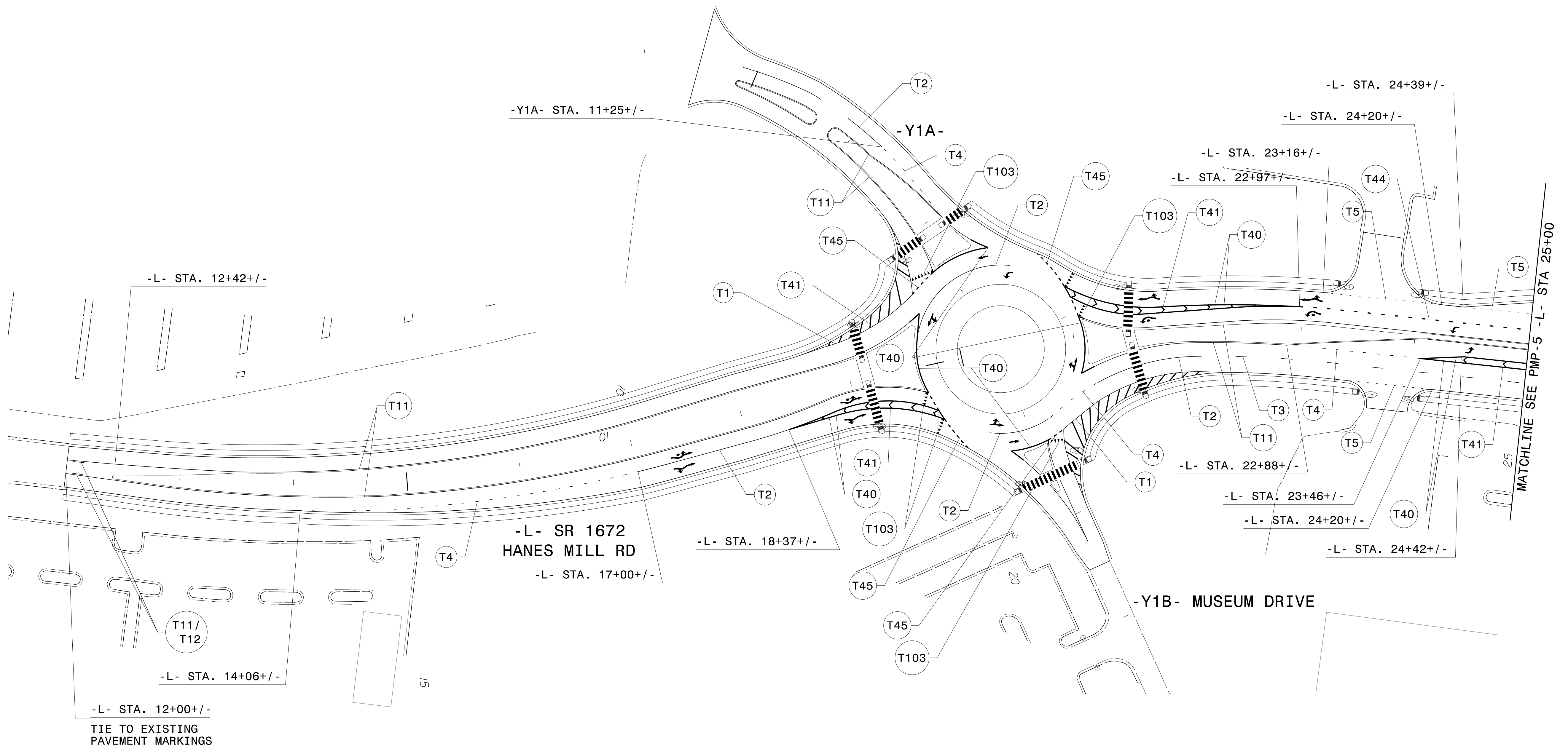
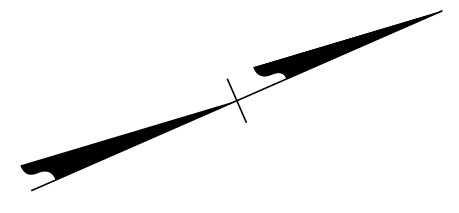

PLANS PREPARED FOR THE NCDOT BY:

M MOTT MACDONALD I & E, LLC
 1101 HAYNES STREET, SUITE 101
 RALEIGH, NC 27604
M MOTT MACDONALD NC LICENSE NO. F-0669

PAVEMENT MARKING DETAIL

3/23/2023
 G:\308350_DDC\2\RC-U-2729\TrafficControl\Signing\Pavement Marking\U-2729_Sgn_PMP_4.dgn
 User:COL85144

APPROVED: _____

DATE: _____

SEAL



**DOCUMENT NOT CONSIDERED FINAL
UNLESS ALL SIGNATURES COMPLETED**

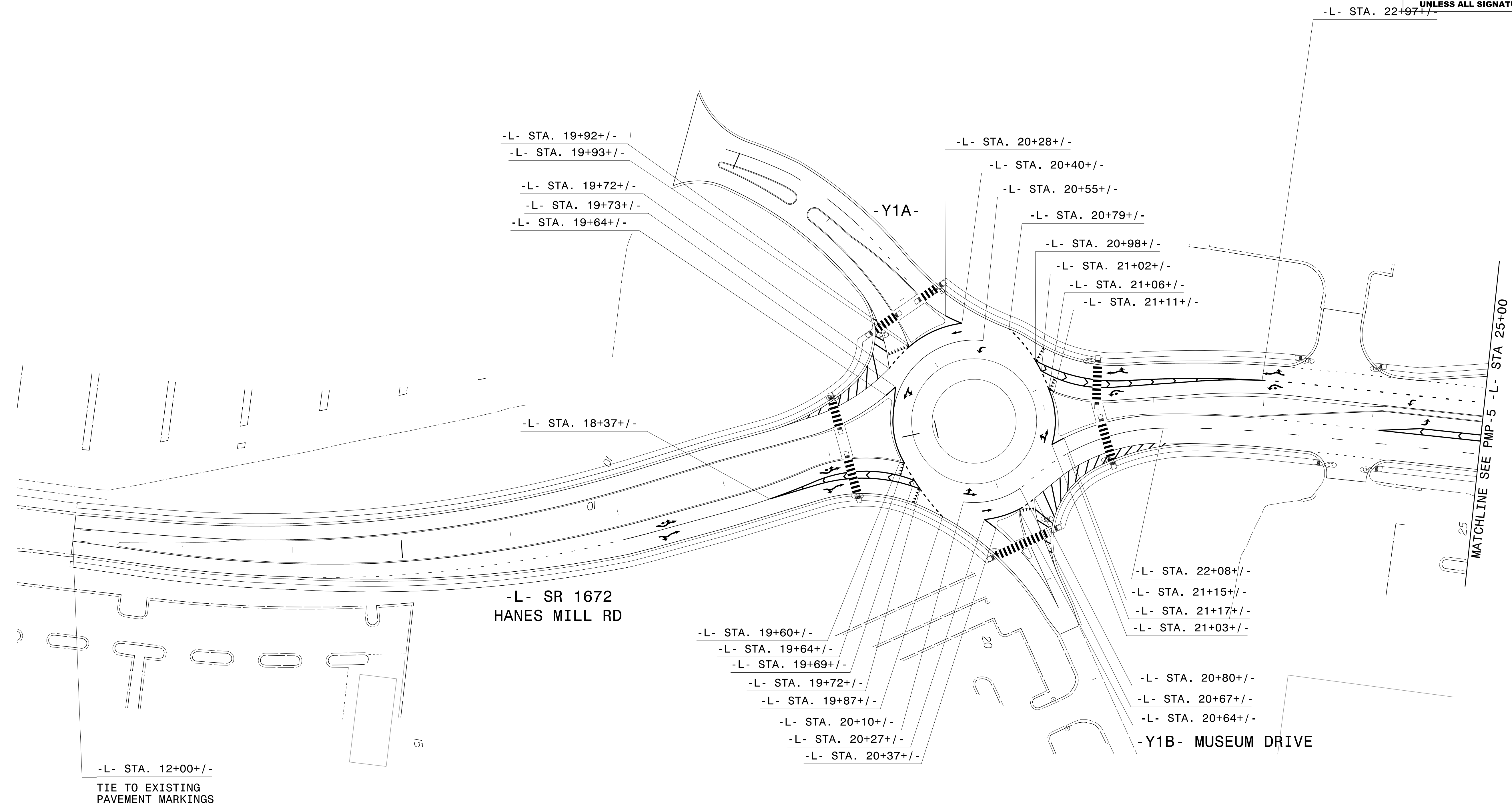
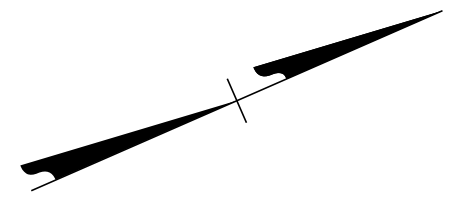

3/23/2023
 G:\308350_DDC\2\RC-U-2729\TrafficControl\Signing\Pavement Marking\U-2729_Sgn_PMP_4A.dgn
 User:COL85144

PLANS PREPARED FOR THE NCDOT BY:

M MOTT MACDONALD I & E, LLC
 1101 HAYNES STREET, SUITE 101
 RALEIGH, NC 27604
M MOTT MACDONALD NC LICENSE NO. F-0669

PAVEMENT MARKING DETAIL

APPROVED: _____

DATE: _____

SEAL



**DOCUMENT NOT CONSIDERED FINAL
UNLESS ALL SIGNATURES COMPLETED**

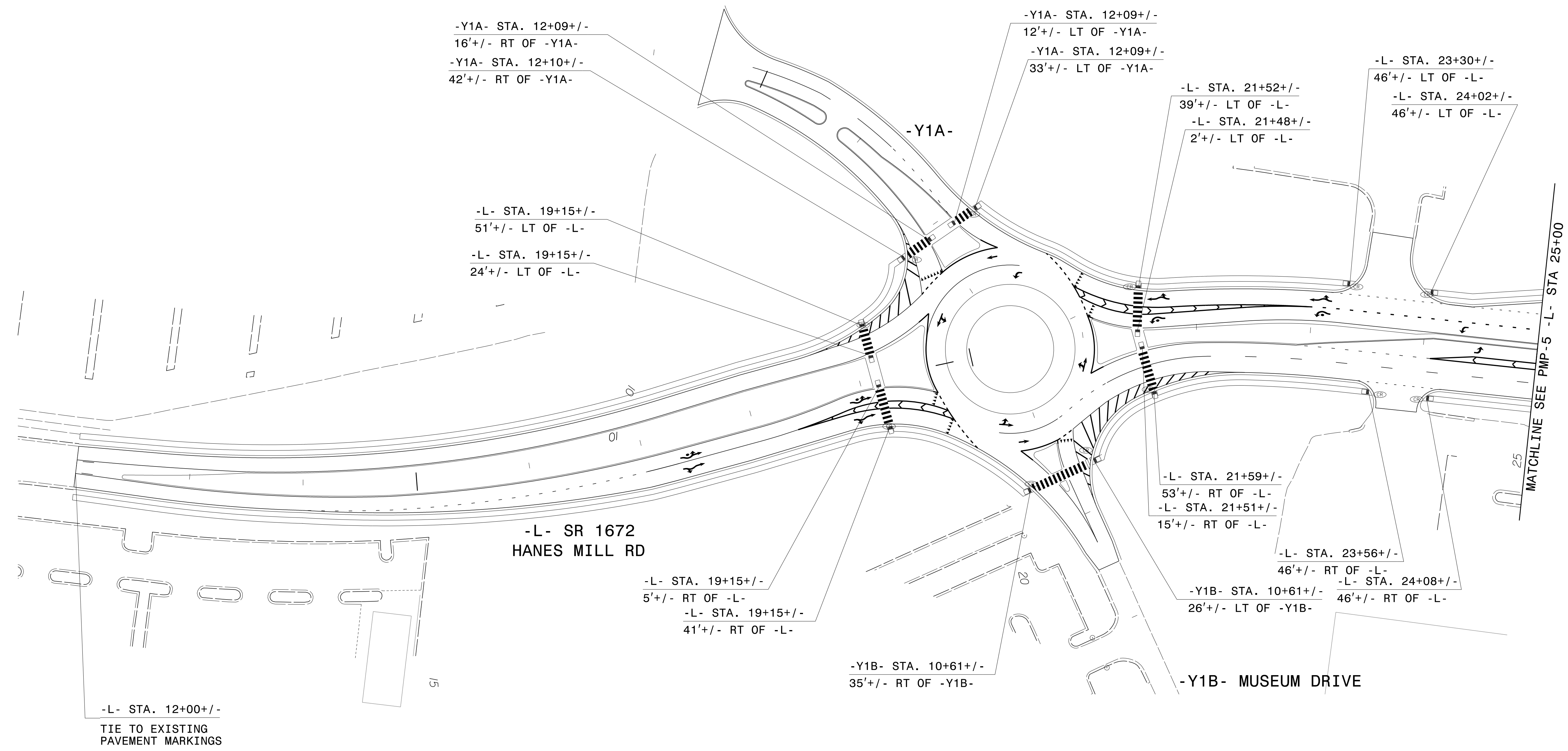
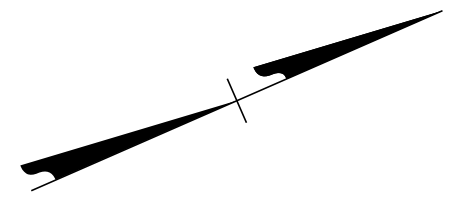

3/23/2023
 G:\308350_DDC\2\NC-U-2729\TrafficControl\Signing\Pavement Marking\U-2729_Sgn_PMP_4B.dgn
 User:COL85144

PLANS PREPARED FOR THE NCDOT BY:

M MOTT MACDONALD I & E, LLC
 1101 HAYNES STREET, SUITE 101
 RALEIGH, NC 27604
M MOTT MACDONALD NC LICENSE NO. F-0669

**PAVEMENT MARKING DETAIL
CURB RAMPS**

Review and record the existing pavement markings and markers before resurfacing at the following locations: -Y4-, -RPA- FROM STA. 17+50 TO -Y4-, -LPA- FROM STA. 13+50 TO -Y4-, -RPB- FROM STA. 23+50 TO -Y4-, -LPB- FROM STA. 15+50 TO -Y4-. Re-establish the new pavement markings and markers using the record of existing markings in conjunction with the 2018 Roadway Standard Drawings. Unless otherwise directed by the engineer, new pavement markings not meeting the current standards should be updated to the 2018 Roadway Standard Drawings. Have existing or proposed *passing zones* reviewed by the engineer before installation. Submit the record of the existing pavement markings seven calendar days before the obliteration of any pavement markings.

- THERMOPLASTIC PAVEMENT MARKING SYMBOLS**
- T70 ↶ LEFT TURN ARROW
 - T71 ↷ RIGHT TURN ARROW
 - T72 ↑ STRAIGHT ARROW
 - T73 ↶ COMBO STRAIGHT/LEFT
 - T79 ↷ MERGE ARROW
 - T80 ↶ WRONG-WAY RAMP ARROW
 - T100 ALPHANUMERIC CHARACTER
 - T103 24" YIELD LINE TRIANGLE
- COLD APPLIED PLASTIC PAVEMENT MARKING SYMBOLS**
- C70 ↶ LEFT TURN ARROW
 - C72 ↑ STRAIGHT ARROW

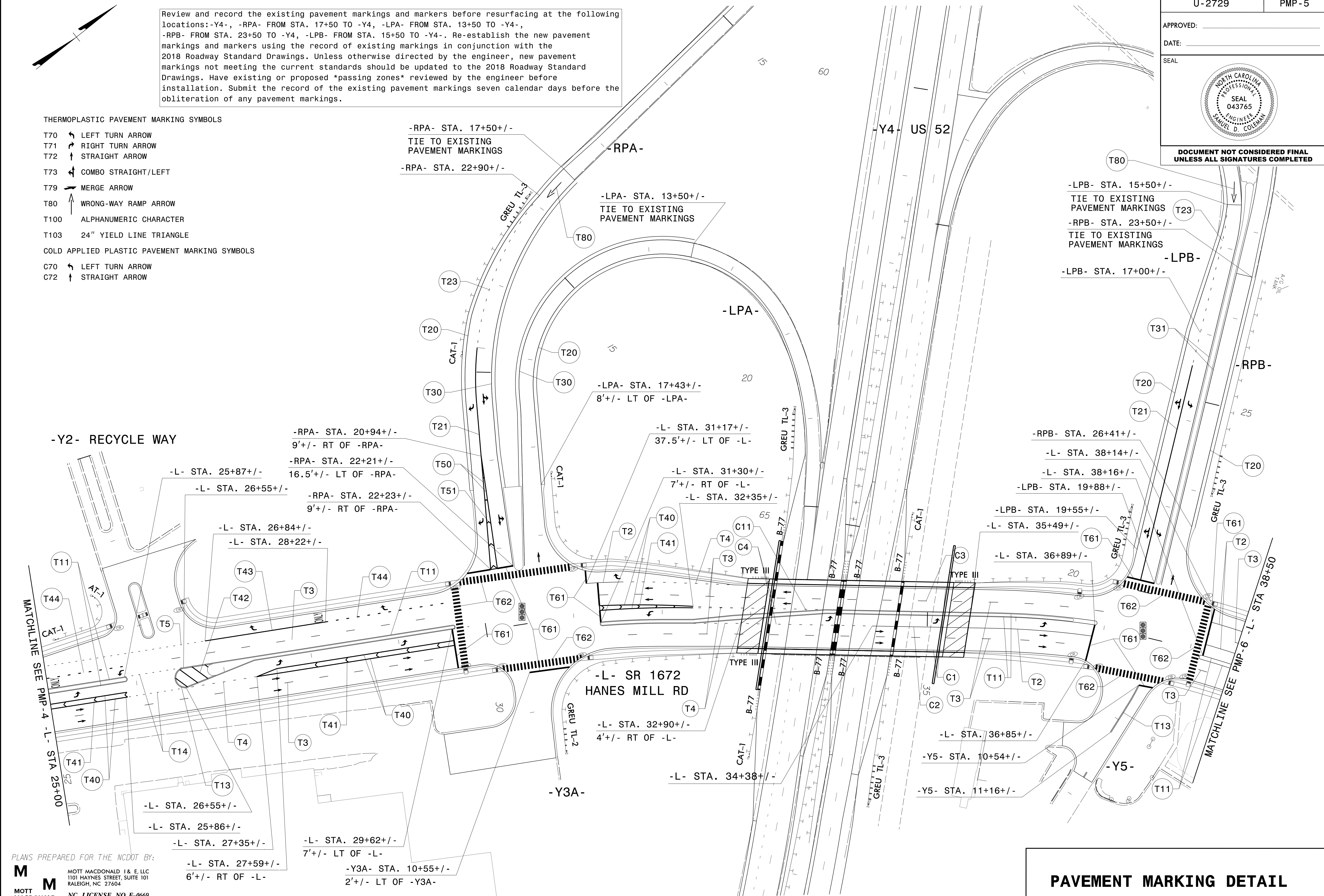

3/23/2023
 G:\306350_DDC\2\ARC-U-2729\TrafficControl\Signing\Pavement Marking-U-2729_Sgn_PMP-5.dgn
 User:10135144

PLANS PREPARED FOR THE NCDOT BY:

M MOTT MACDONALD I & E, LLC
 1101 HAYNES STREET, SUITE 101
 RALEIGH, NC 27604
 NC LICENSE NO. F-0669

PAVEMENT MARKING DETAIL

APPROVED: _____
 DATE: _____



DOCUMENT NOT CONSIDERED FINAL
 UNLESS ALL SIGNATURES COMPLETED

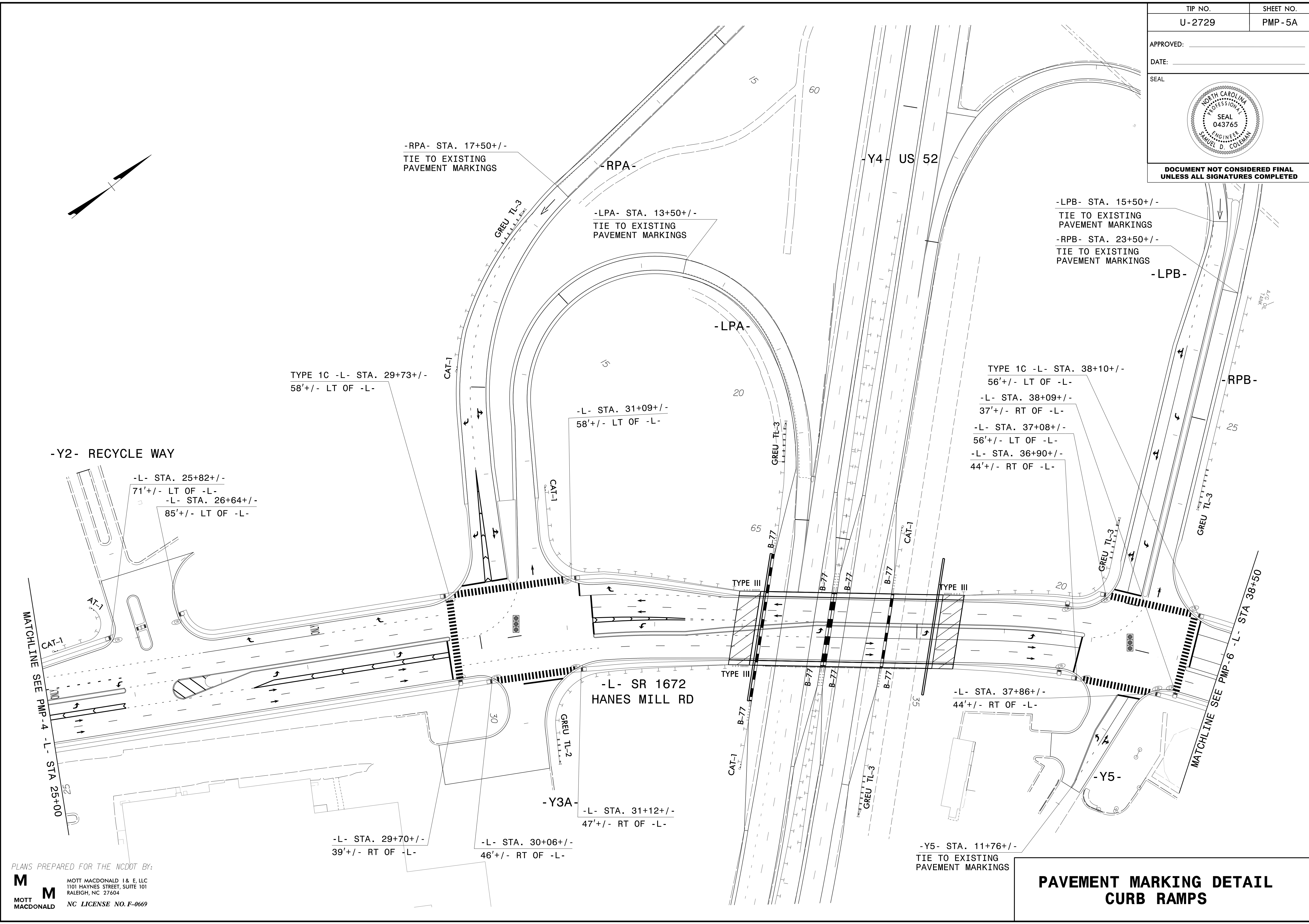
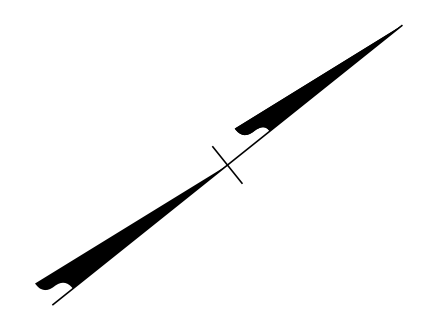

3/23/2023
 G:\306350_PDDC\2\ARC-U-2729\TrafficControl\Signing\Pavement Marking\U-2729_Sgn_PMP_5A.dgn
 User:10185144

PLANS PREPARED FOR THE NCDOT BY:
M MOTT MACDONALD I & E, LLC
 1101 HAYNES STREET, SUITE 101
 RALEIGH, NC 27604
M MOTT MACDONALD NC LICENSE NO. F-0669

**PAVEMENT MARKING DETAIL
 CURB RAMPS**

- THERMOPLASTIC PAVEMENT MARKING SYMBOLS
- T70 LEFT TURN ARROW
 - T71 RIGHT TURN ARROW
 - T72 STRAIGHT ARROW
 - T73 COMBO STRAIGHT/LEFT
 - T79 MERGE ARROW
 - T100 ALPHANUMERIC CHARACTER
 - T103 24" YIELD LINE TRIANGLE
 - T112 FISH-HOOK RIGHT/STRAIGHT ARROW
 - T116 FISH-HOOK W/CIRCLE LEFT ARROW
 - T117 FISH-HOOK W/CIRCLE LEFT/STRAIGHT ARROW

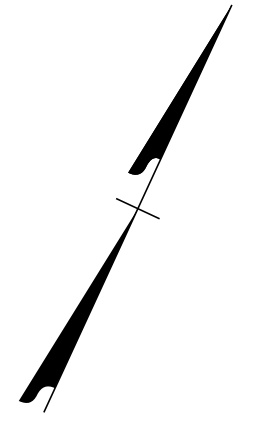

TIP NO. U-2729	SHEET NO. PMP-6
APPROVED: _____	
DATE: _____	
SEAL	
<p>DOCUMENT NOT CONSIDERED FINAL UNLESS ALL SIGNATURES COMPLETED</p>	

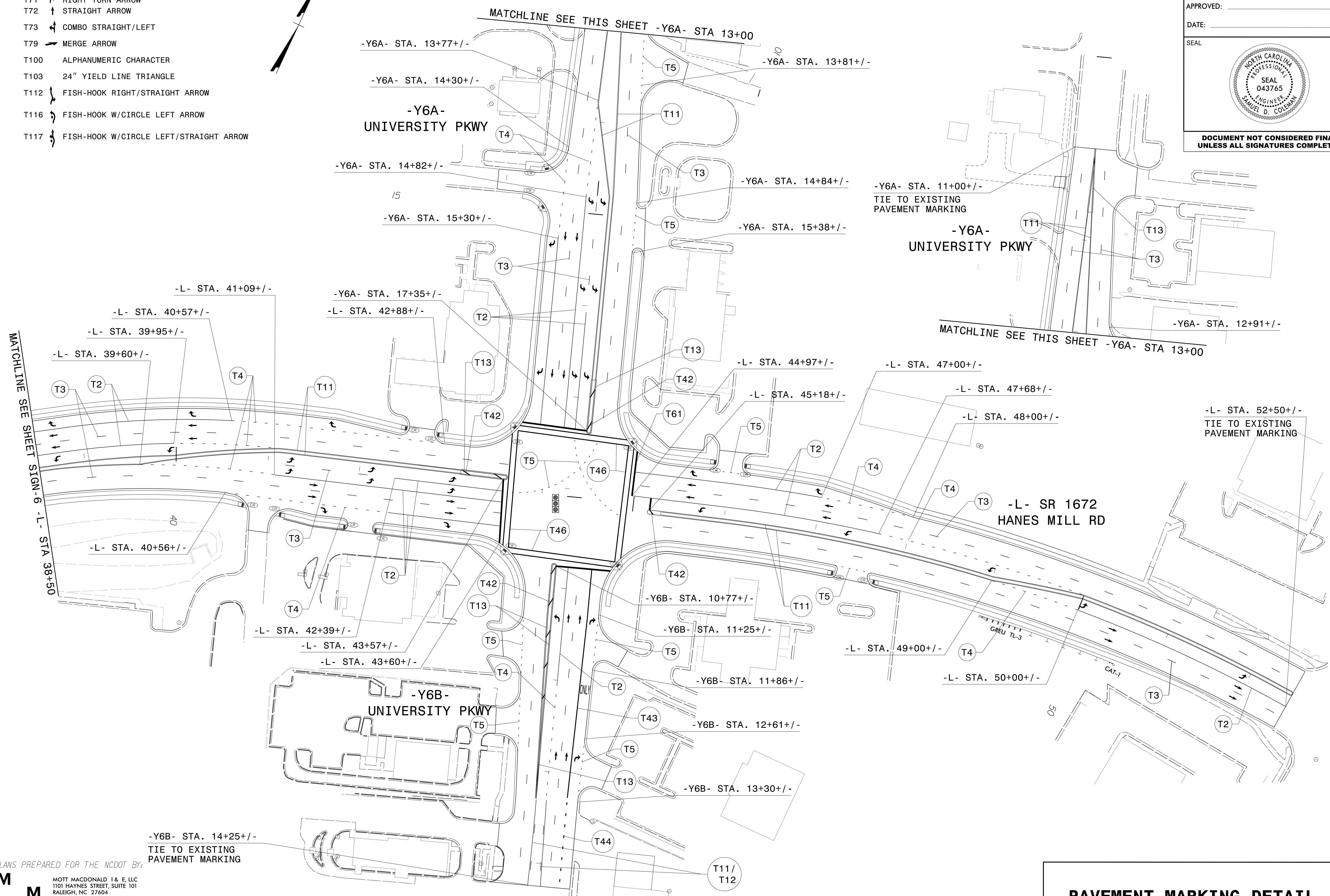

PLANS PREPARED FOR THE NCDOT BY:

M MOTT MACDONALD I & E, LLC
1101 HAYNES STREET, SUITE 101
RALEIGH, NC 27604
NC LICENSE NO. F-0669

PAVEMENT MARKING DETAIL

3/23/2023 G:\308350_DDC\2\ARC-U-2729\TrafficControl\Signing\Pavement Marking-U-2729_Sgn_PMP_6.dgn User:COL85144

TIP NO. U-2729	SHEET NO. PMP-6A
APPROVED: _____	
DATE: _____	
SEAL	
	
DOCUMENT NOT CONSIDERED FINAL UNLESS ALL SIGNATURES COMPLETED	

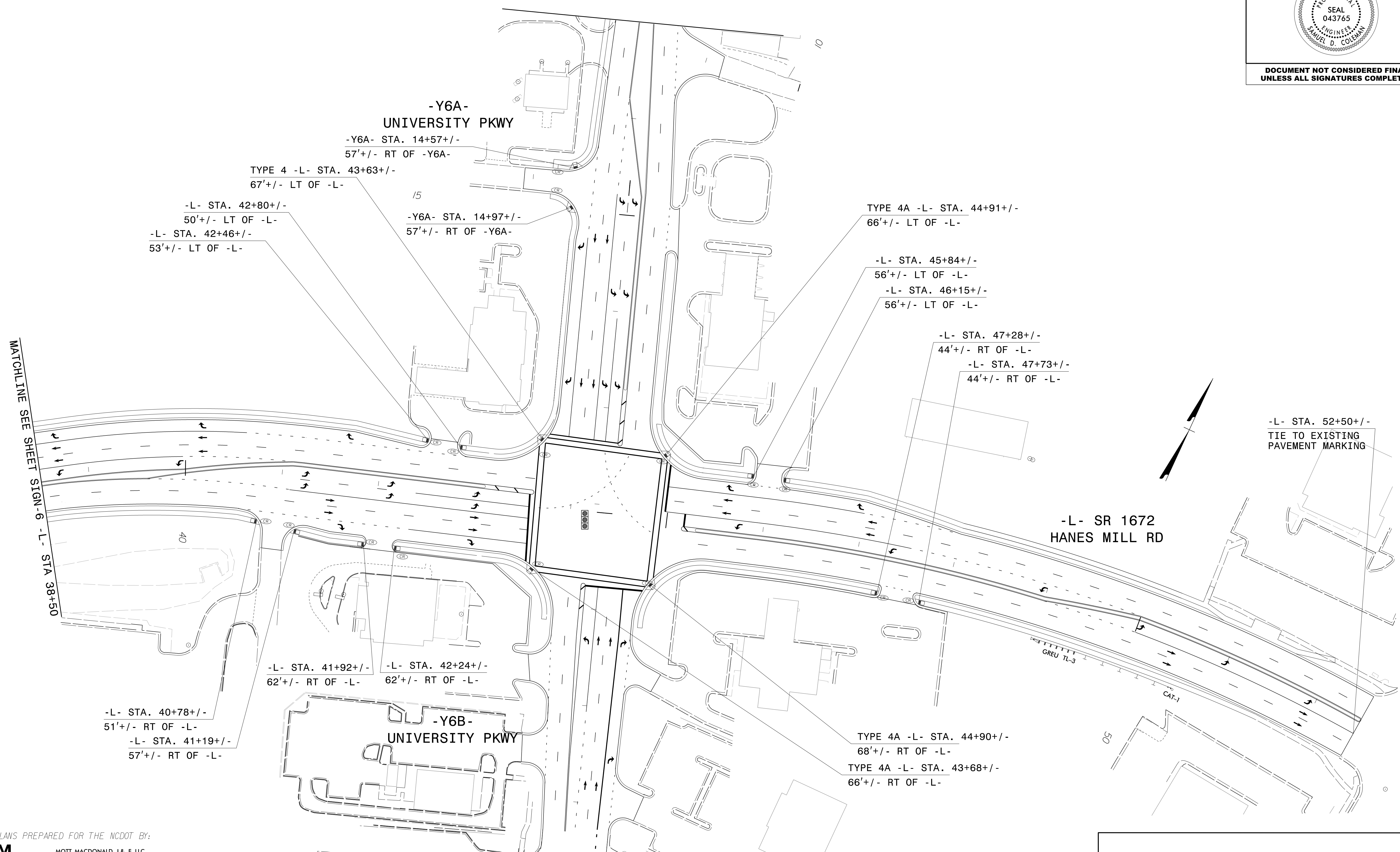

MATCHLINE SEE SHEET SIGN-6 -L- STA 38+50

PLANS PREPARED FOR THE NCDOT BY:

M
MOTT MACDONALD
1101 HAYNES STREET, SUITE 101
RALEIGH, NC 27604
NC LICENSE NO. F-0669

**PAVEMENT MARKING DETAIL
CURB RAMPS**

3/23/2023 G:\308350_DDC\2\ARC-U-2729\TrafficControl\Signing\Pavement Marking\U-2729_Sgn_PMP_6A.dgn User:COL85144