

18 CHANNEL CONFLICT MONITOR PROGRAMMING DETAIL

(remove jumpers and set switches as shown)

REMOVE DIODE JUMPERS 1-5, 1-6, 1-9, 1-10, 1-11, 1-12, 1-15, 2-5, 2-6, 2-9, 2-10, 2-11, 2-12, 2-13, 2-15, 4-10, 4-12, 4-14, 5-9, 5-11, 5-12, 5-13, 6-9, 6-10, 6-11, 6-13, 6-15, 9-10, 9-11, 9-12, 9-13, 9-15, 10-11, 10-12, 10-13, 10-14, 10-15, 11-12, 11-13, 11-15, 12-13, 12-14, 13-15.

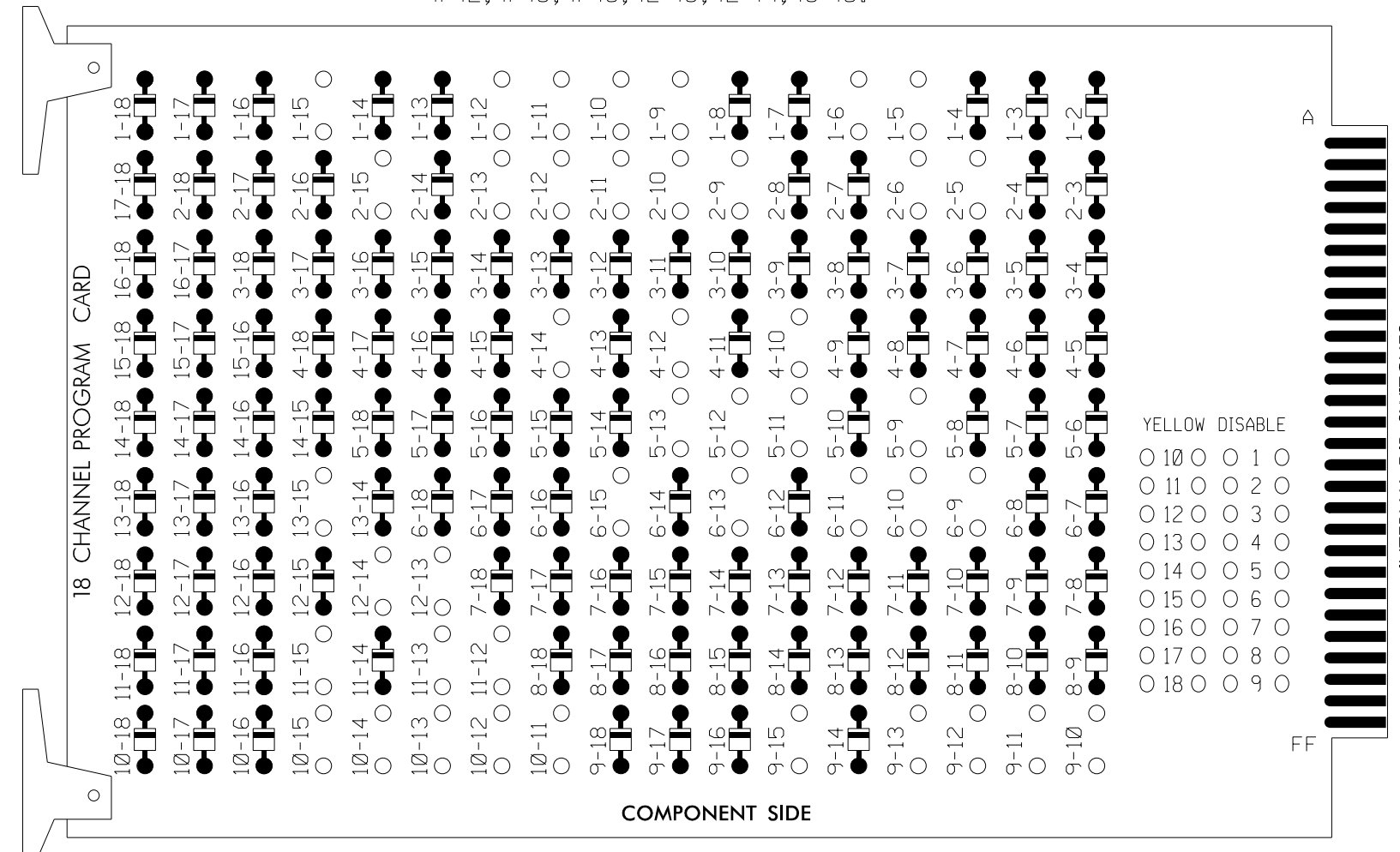

REMOVE JUMPERS AS SHOWN

NOTES:

- Card is provided with all diode jumpers in place. Removal of any jumper allows its channels to run concurrently.
- Ensure jumpers SEL2-SEL5 and SEL9 are present on the monitor board.
- Ensure that Red Enable is active at all times during normal operation.
- Connect serial cable from conflict monitor to comm. port 1 of 2070 controller. Ensure conflict monitor communicates with 2070.

■ = DENOTES POSITION OF SWITCH

NOTES

- To prevent "flash-conflict" problems, insert red flash program blocks for all unused vehicle load switches in the output file. The installer shall verify that signal heads flash in accordance with the Signal Plans.
- Enable Simultaneous Gap-Out for all Phases.
- Program phases 2 and 6 for Variable Initial and Gap Reduction.
- Program phases 2 and 6 for Startup In Green.
- Program phases 2, 4 and 6 for Startup Ped Call.
- Program phases 2 and 6 for Yellow Flash, and overlap 1 and 2 as Wag Overlaps.
- The cabinet and controller are part of the Winston-Salem Signal System.

EQUIPMENT INFORMATION

CONTROLLER.....2070
 CABINET.....332 W/ AUX
 SOFTWARE.....ECONOLITE OASIS
 CABINET MOUNT.....BASE
 OUTPUT FILE POSITIONS...18 WITH AUX. OUTPUT FILE
 LOAD SWITCHES USED.....S1,S2,S3,S4,S5,S6,S7,S8,
 S9,AUX S1,AUX S2,AUX S4,AUX S5
 PHASES USED.....1,2,2PED,3,4,4PED,5,6,6PED
 OVERLAP "A".....1+2
 OVERLAP "B".....4+6
 OVERLAP "C".....5+6
 OVERLAP "D".....4+5

SIGNAL HEAD HOOK-UP CHART

LOAD SWITCH NO.	S1	S2	S3	S4	S5	S6	S7	S8	S9	S10	S11	S12	AUX S1	AUX S2	AUX S3	AUX S4	AUX S5	AUX S6					
CMU CHANNEL NO.	1	2	13	3	4	14	5	6	15	7	8	16	9	10	17	11	12	18					
PHASE	1	2	2 PED	3	4	4 PED	5	6	6 PED	7	8	8 PED	OLA	OLB	SPARE	OLC	OLD	SPARE					
SIGNAL HEAD NO.	11	21,22	P21, P22	31	32	41,42	P41, P42	51	61,62	P61, P62	NU	NU	NU	11	63	NU	51	43	NU				
RED		128		116	116	101			134					A124				A101					
YELLOW	*	129		117	117	102		*	135														
GREEN		130		118	118	103			136														
RED ARROW														A121				A114					
YELLOW ARROW														A122	A125			A115	A102				
FLASHING YELLOW ARROW														A123	A126			A116	A103				
GREEN ARROW	127								133														
Hand														113				104		119			
Walker																				115	106		121

NU = Not Used

* Denotes install load resistor. See load resistor installation detail this sheet.

★ See pictorial of head wiring in detail this sheet.

INPUT FILE POSITION LAYOUT

(front view)

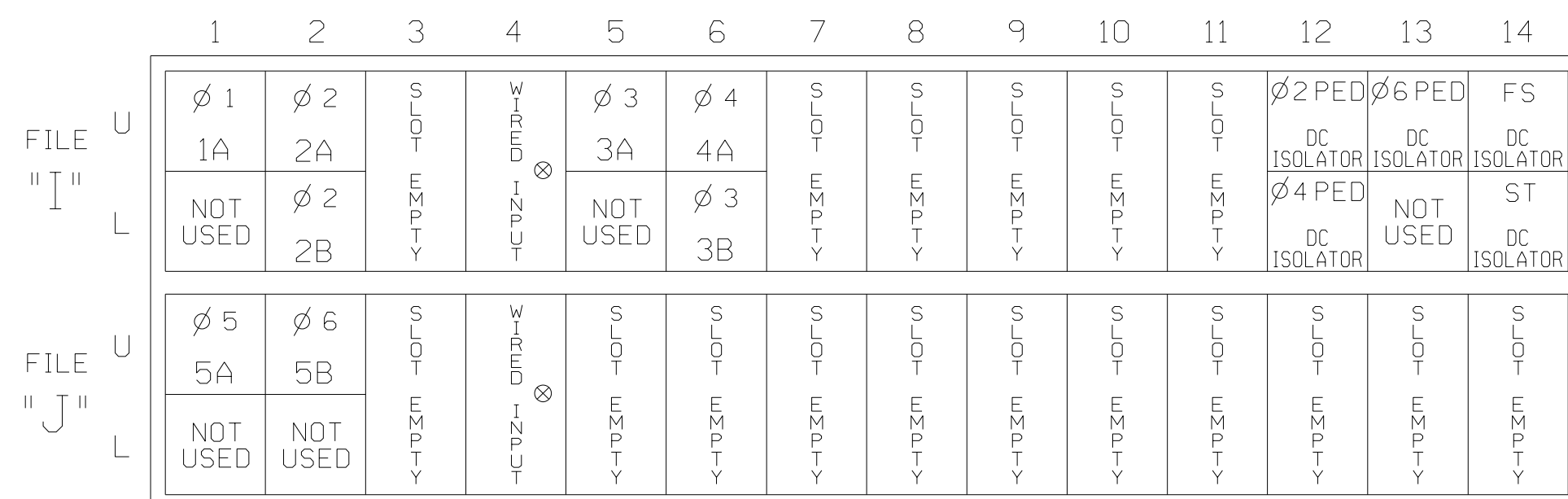

EX.: 1A, 2A, ETC. = LOOP NO.'S

FS = FLASH SENSE
 ST = STOP TIME

⊗ Wired Input - Do not populate slot with detector card

INPUT FILE CONNECTION & PROGRAMMING CHART

LOOP NO.	LOOP TERMINAL	INPUT FILE POS.	PIN NO.	INPUT ASSIGNMENT NO.	DETECTOR NO.	NEMA PHASE	CALL	EXTEND	FULL TIME DELAY	STRETCH TIME	DELAY TIME
1A ¹	TB2-1,2	I1U	56	18	1	1	Y	Y			15
	-	J4U	48	10★	26	6	Y	Y	Y		3
	-	I1U	56	18★	51	1	Y	Y			3
2A	TB2-5,6	I2U	39	1	2	2	Y	Y			
2B	TB2-7,8	I2L	43	5	12	2	Y	Y			
3A	TB4-5,6	I5U	58	20	3	3	Y	Y			5
3B	TB4-11,12	I6L	45	7	14	3	Y	Y			15
4A	TB4-9,10	I6U	41	3	4	4	Y	Y			
5A ²	TB3-1,2	J1U	55	17	5	5	Y	Y			15
	-	I4U	47	9★	22	2	Y	Y	Y		3
	-	J1U	55	17★	55	5	Y	Y			3
5B	TB3-5,6	J2U	40	2	6	5	Y	Y			15
PED PUSH BUTTONS											
P21,P22	TB8-4,6	I12U	67	29	PED 2	2 PED					
P41,P42	TB8-5,6	I12L	69	31	PED 4	4 PED					
P61,P62	TB8-7,9	I13U	68	30	PED 6	6 PED					

NOTE:
 INSTALL DC ISOLATORS IN INPUT FILE SLOTS 112 AND 113.

¹Add jumper from I1-W to J4-W, on rear of input file.

²Add jumper from J1-W to I4-W, on rear of input file.

★ See Input Page Assignment programming details on sheets 3 and 4.

INPUT FILE POSITION LEGEND: J2L

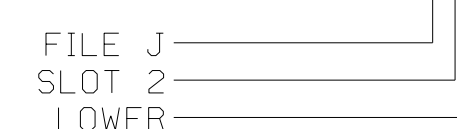

THIS ELECTRICAL DETAIL IS FOR THE SIGNAL DESIGN: 09-0775
 DESIGNED: March 2023
 SEALED: April 25, 2023
 REVISED:

FYA SIGNAL WIRING DETAIL

(wire signal heads as shown)

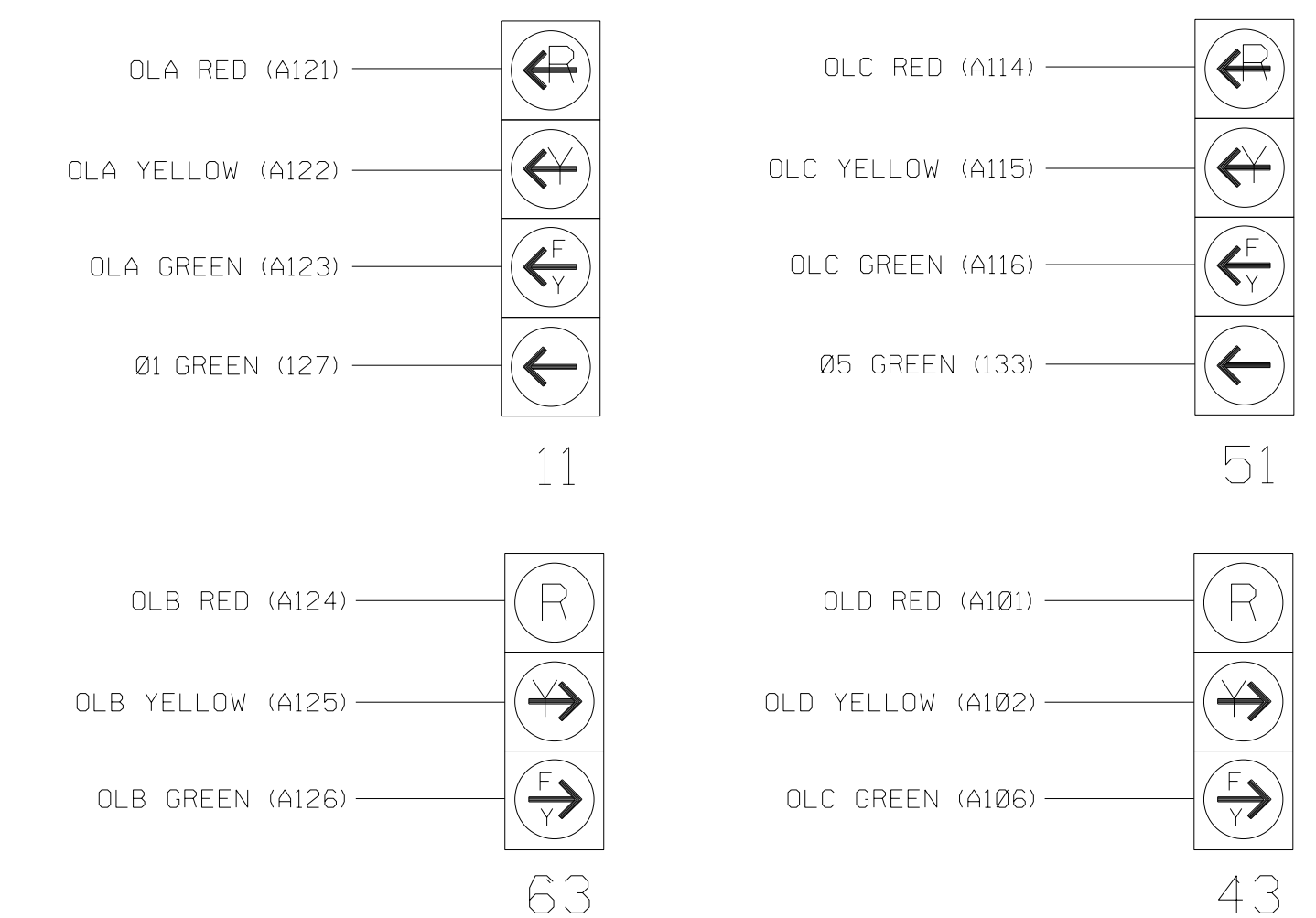

NOTE

The sequence display for signal heads 11 and 51 requires special logic programming. See sheet 2 for programming instructions.

LOAD RESISTOR INSTALLATION DETAIL

(install resistors as shown below)

ACCEPTABLE VALUES	
VALUE (ohms)	WATTAGE
1.5K - 1.9K	25W (min)
2.0K - 3.0K	10W (min)

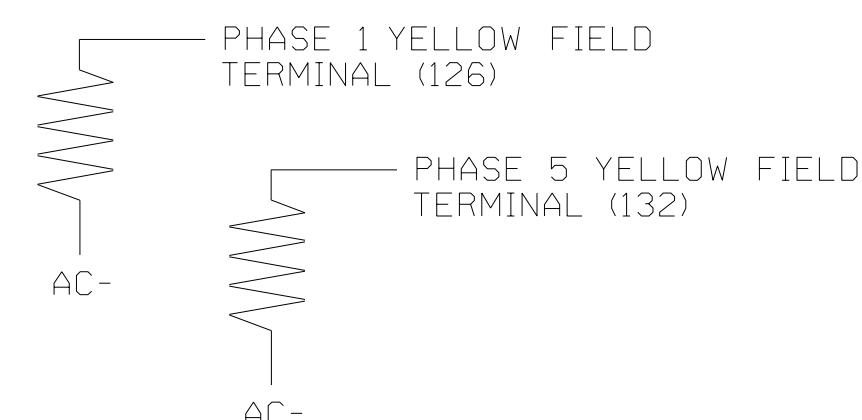

COUNTDOWN PEDESTRIAN SIGNAL OPERATION

Countdown Ped Signals are required to display timing only during Ped Clearance Interval. Consult Ped Signal Module user's manual for instructions on selecting this feature.

Electrical Detail - Final Design - Sheet 1 of 5

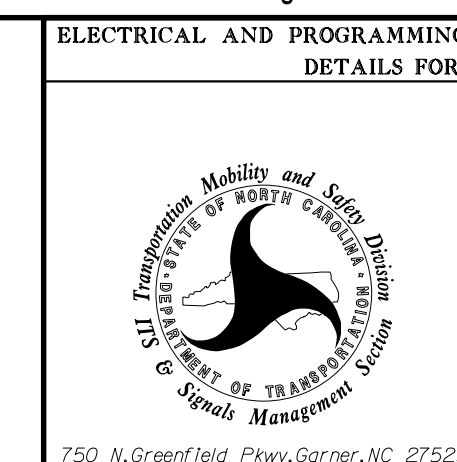
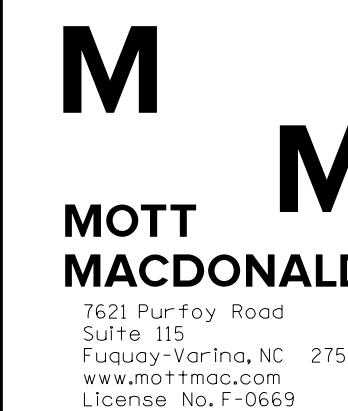

SR 1672 (Hanes Mill Road) at US 52 SB Ramps

Division 9 Forsyth County Winston-Salem

PLAN DATE: March 2023 REVIEWED BY: RW Thompson

PREPARED BY: LD Stouchko REVIEWED BY:

REVISIONS	INIT.	DATE

DOCUMENT NOT CONSIDERED FINAL UNLESS ALL SIGNATURES COMPLETED



SIG. INVENTORY NO. 09-0775